

Product Safety & Reliability Department
Telephone: 877-JLG-SAFE
Facsimile: 301-745-3713
E-mail Address: productsafety@jlg.com



Attn: Safety Manager or Service Manager
Subject: Lifting Hook Attachments

Per your request, JLG Industries, Inc. submits the following:

You have requested approval to utilize a non-JLG supplied fork mounted lifting hook attachment similar to what is shown in Figure #1 on a JLG telehandler.

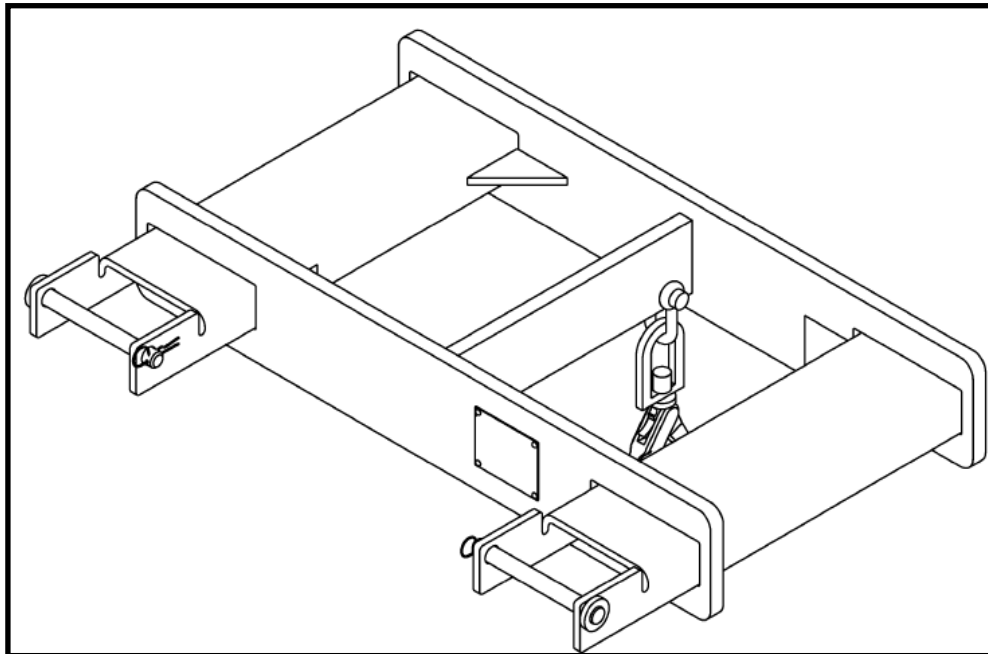

Figure #1

JLG authorizes the use of non-JLG fork mounted lifting hook attachments provided the following criteria are strictly adhered to:

- The manufacturer of the lifting hook attachment is responsible for:
 - Design,
 - Fabrication,
 - Workmanship,
 - Structural integrity,
 - Fit and function,
 - Overall quality
 - Clearly marking the rated capacity.
- The hook location on the lifting hook attachment must not exceed a horizontal distance of 24 inches from the heel of the fork when installed.

- The appropriate carriage capacity chart for the telehandler model must be used. Reference the appropriate Operation and Safety Manual for additional details. Weight of lifting hook attachment and rigging must be included as part of total load being lifted.
- Pallet/lumber forks of an appropriate load rating must be used. Do not use with cubing/block forks.
- To help protect against the attachment from being disengaged from the forks, pins must be provided on the lifting hook attachment that must be used to secure the lifting hook behind the heel of each fork. It cannot be secured by the use of chains, straps or clamps directly to the forks, fork carriage, load bar and/or the boom.
- Refer to the appropriate Operation and Safety Manual for the telehandler model the lifting hook will be used on. This literature provides information regarding appropriate methods for lifting suspended loads.
- Do not use a lifting hook attachment on 6 ft. masts or 8 ft. towers.
- Do not use a lifting hook attachment with carriages capable of rotating (i.e. side tilt and swing carriages) without disabling the rotation feature(s).
- All applicable safety procedures (country, local, employer, manufacturer, etc.) shall be strictly adhered to.
- Only trained and authorized operators shall be permitted to operate the referenced telehandler. Training includes, but not limited to, the reading and understanding of the Operators & Safety Manual.
- The operator must obtain any additional training in the proper operation of the lifting hook attachment that may be required. Please consult with your local, state, and employer regulations.

The current owner, operator, and user are responsible for the safe and proper utilization and selection of the non-JLG lifting hook attachment. JLG Industries assumes no responsibility or liability for any and all incidents involving personal injury, property damage, or equipment damage, which may occur from utilization of the non-JLG lifting hook attachment.

Should you have any questions, or require additional information, please advise.

Regards,
JLG INDUSTRIES, INC.
Product Safety and Reliability Department