

600AJ HC3

ARTICULATING HI-CAPACITY BOOM LIFT



HC3

3 Capacity Zones - Each rated for 3 occupants + tools/materials



Performance

Platform Height	60 ft	18.3 m
Horizontal Outreach	40 ft 6.9 in.	12.37 m
Up and Over Clearance	26 ft 6.4 in.	8.1 m
Swing	360 Degrees Continuous	
Platform Capacity		
600AJ HC3 - Restricted	750/1000 lb	340/454 kg
600AJ HC3 - Unrestricted	660 lb	300 kg
Platform Rotator	180 Degrees Hydraulic	
Jib Range of Articulation	130 Degrees (+70, -60)	
Weight		
600AJ HC3	26,057 lb	11,819 kg
Max. Ground Bearing Pressure		
600AJ HC3	96 psi	6.75 kg/cm2
Drive Speed 4WD	4.25 mph	6.8 kph
Gradeability 4WD	45%	
Tilt Cut Out	5 Degrees	
Axle Oscillation	8 in. 0.2 m	
Turning Radius		
Inside	7 ft 6 in.	2.15 m
Outside	16 ft 11.3 in.	5.17 m

Standard Specifications

Power Source

Dual Fuel Engine		
Ford MSG425	84 hp	62 kw
Diesel Engine		
Deutz D2.9L4 Tier 4 Final	49 hp	36.4 kw
Deutz D2011L04	49 hp	36.4 kw
Fuel Tank Capacity	30 gal.	113.6 L

Hydraulic System

• Capacity	30.6 gal.	115.8 L
• Auxiliary Power	12V DC	

Tires

• Standard	IN355/55D-6.25 Foam Filled
------------	----------------------------

Standard Features

- Oscillating Axle
- 180 Degree Hydraulic Platform Rotator
- 110V-AC Receptacle in the Platform
- 5 Degree Tilt Alarm/Indicator Light
- Swing-Out Engine Tray
- 12V-DC Auxiliary Power
- Hourmeter
- Horn
- Control ADE® System
- Proportional Controls
- Gull-Wing Engine Hood
- LED Light Panel at Platform and Ground Control Consoles
- Status Light Panel*
- Lifting/Tie Down Lugs
- All Motion Alarm
- Glow Plugs (Diesel Engines)
- Load Sensing System
- SkyGuard SkyLine™

Accessories & Options

- Platform: 36 x 72 in. (0.91 x 1.83 m)
- Fall Arrest Platform, Rear Entry: 36 x 96 in. (0.91 x 2.44 m)
- Self-Closing Gate
- SkySense™
- Soft Touch System
- Operator Tool Tray
- 43.5 lb (19.7 kg) Propane Tank
- Cold Weather Package¹
- Hostile Environment Kit²
- Flashing Amber Beacon
- Arctic Package³
- Accessory Packages:
 - SkyPower®
 - SkyWelder®

* Provides indicator lights at platform and ground control consoles to show system distress, 5 degree tilt light, and foot switch status.

1. Includes Battery Blanket, Hydraulic Tank Heater, Block Heater.

2. Includes console cover, boom wipers and cylinder bellows.

3. Includes Arctic Hydraulic Hoses (Drive, Steer), Main Boom Cable, Extreme Cold Engine Oil, Fuel Conditioner, Engine Block Heater, Battery Blanket, Glow Plugs, Hydraulic Tank Heater, Oversized Footswitch And Arctic Hydraulic Oil.

Note: Some options may increase lead time, and some option combinations may not be available.

Additional accessories and options available via JLG Aftermarket.

600AJ HC3

ARTICULATING HI-CAPACITY BOOM LIFT



Dimensions

All dimensions are approximate.

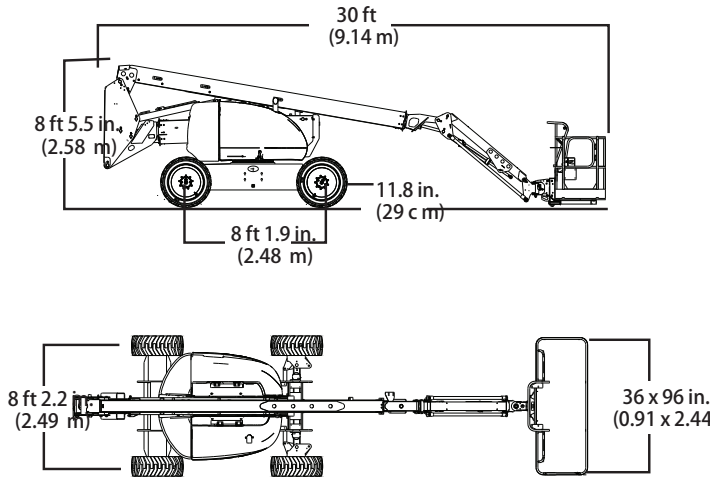

Reach Diagram

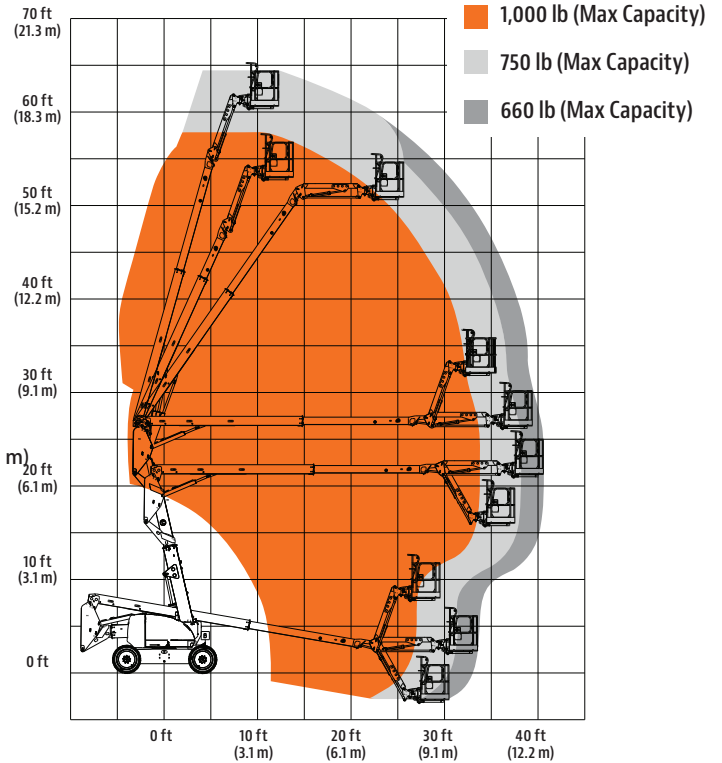

The JLG "1 & 5" Warranty

We provide coverage for one (1) full year, and cover all specified major structural components for five (5) years. Due to continuous product improvements, we reserve the right to make specification and/or equipment changes without prior notification. This machine meets or exceeds applicable ANSI and CSA requirements based on machine configuration as originally manufactured for intended applications. Please reference the serial number plate on the machine for additional information.

JLG South East Asia Branch

35 Tuas Avenue 2,
Singapore 639464
Tel: +65 65919368

Part No.: 3131126
R0820
Printed in USA



JLG Industries, Inc.

1 JLG Drive
McConnellsburg, PA 17233-9533
Telephone 717-485-5161
Toll-free in US 877-JLG-LIFT
Fax 717-485-6417
www.jlg.com

An Oshkosh Corporation Company