

# R3246

ELECTRIC SCISSOR LIFT



## Performance

Platform Height	9.80 m
Platform Capacity	320 kg
Capacity on Platform Extension	120 kg
Occupants (Indoor / Outdoor)	2/1
Lift/Lower Time	50/37 Seconds
Maximum Drive Height	Full Height
Weight*	2,500 kg
Drive Speed–Elevated	0.8 km/h
Drive Speed–Lowered	3.5 km/h
Gradeability	25%
Turning Radius (Inside)	Zero
Turning Radius (Outside)	2.4 m

\* Certain options or country standards will increase weight.

## Standard Specifications

### Power Source

Batteries	4 x 6V 220 amp-hr
Charger	27 amp
Drive	Hydraulic Front-wheel

### Hydraulic Reservoir

• Capacity	15 L
• Pump	Fixed Displacement Gear

### Tires

• Tire Size/Type (Non-Marking)	406 x 127 mm
--------------------------------	--------------

### Brakes

- Multi-Disc Friction

## Standard Features

- Proportional Controls
- Battery Condition Indicator
- All Motion Alarm
- 27 amp Multi-Function Universal Charger
- Horn
- Hourmeter
- Tilt Alarm and Light
- Lanyard Attach Points
- Moveable, Removable Platform Control
- Nickel Plated Pins
- Lubrication Free Scissor Arm Bushings
- Scissor Maintenance Prop
- Self-centering Arm Stack
- Active Pothole Protection System
- Lifting and Tie Down Points
- Fork Lift Pockets
- Foot-Actuated Deck Extension
- Steel Swing-Out Doors
- Variable Tilt Visual Zone Indicator
- Manual Descent Cable
- Diamond Tread Steel Deck
- Greaseless Kingpin Joints
- Analyzer Port for Diagnostics
- Dynamic Braking
- Flashing Amber Beacon
- Self Closing, Self Latching Gate
- MDI (Ground)
- Drive Motor Covers



- AS/NZS 1418.10 Compliance

## Accessories & Options

- 220 Amp-Hour AGM Batteries
- Fire Extinguisher
- Anti-Vandalism Package for Ground Controls and Platform Controls
- Ambient Noise (Squawker) Alarm
- AC Outlet To Platform incl. ELCB
- Pipe Racks
- ClearSky
- Access Control
- Mobile Control
- SkySense

# R3246

ELECTRIC SCISSOR LIFT



## Dimensions

All dimensions are approximate.

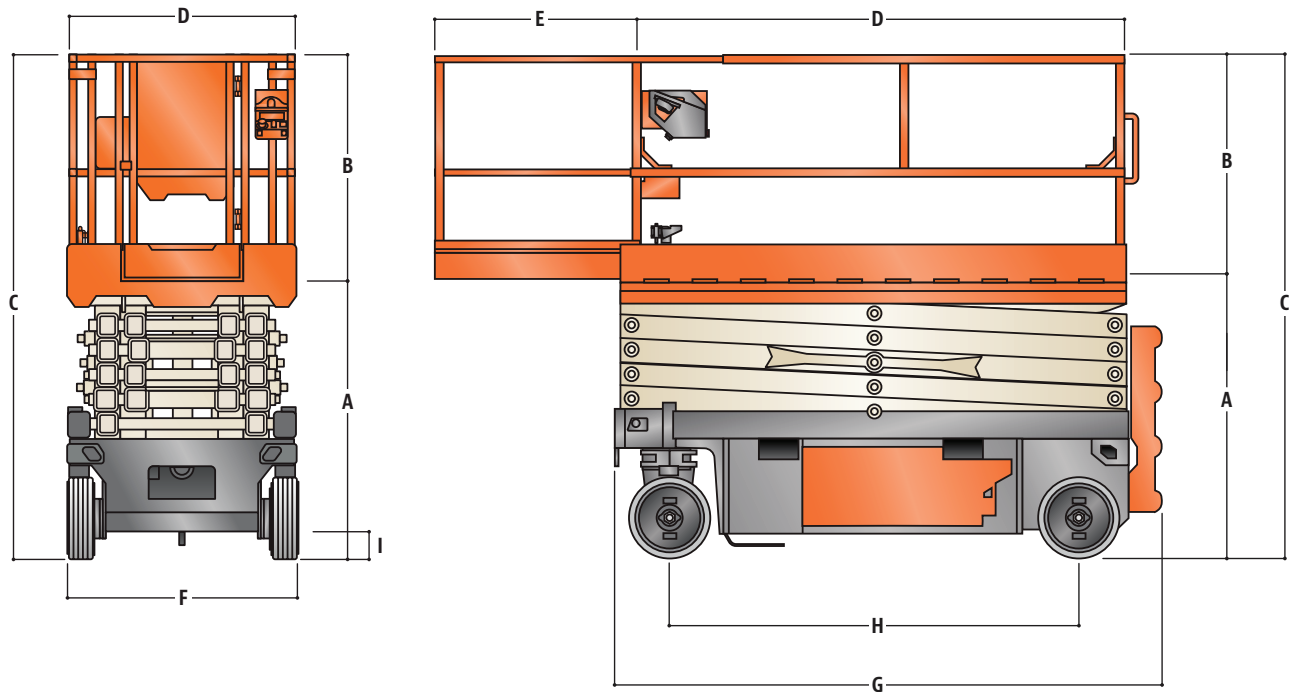

A. Platform Height-Lowered	1.30 m
B. Platform Railing Height	1.13 m
C. Overall Height (Rails Up)	2.50 m
(Rails lowered)	2.00 m
D. Platform Size	1.10 m x 2.10 m

E. Platform Extension	0.91 m
F. Overall Width	1.17 m
G. Overall Length	2.40 m
H. Wheelbase	1.90 m
I. Ground Clearance	0.10 m

## The JLG "1 & 5" Warranty

JLG Industries, Inc. backs its products with its exclusive "1 & 5" Warranty. We provide coverage on all products for one (1) full year and cover all specified major structural components for five (5) years. Due to continuous product improvements, we reserve the right to make specification and/or equipment changes without prior notification. This machine meets or exceeds AS/NZS 1418.10 2011 as originally manufactured for intended applications.

Part No.: AU  
R013020



**JLG Industries (Australia)**  
358 Park Road  
Regents Park, NSW 2143  
Telephone 02 8718 6300  
Fax 02 8718 6377  
[www.jlg.com.au](http://www.jlg.com.au)

**An Oshkosh Corporation Company**