

# Model 1500AJP

## ARTICULATING BOOM LIFTS



### PRODUCTIVITY REDEFINED

- Providing largest working outreach in the industry while class-leading capacity allows for more materials to the work area
- Quickstik enabled boom operation means operators spend more time working and less time positioning
- Automatic axle deployment allows for set-up within 1 minute
- Minimal work interruption due to driveability at full height

### OPERATOR CONFIDENCE

- More stable operation due to wide axle foot print
- LCD display in platform keeps operator fully informed on location in work envelope
- Advanced hydraulics and cylinder dampening provides for smooth ride and deployment functions
- Equipped with JLG SkyGuard™ protecting the operator control panel

### TRANSPORTABILITY

- Fits on most standard trailers
- 50/50 weight distribution enables more stable on- and offloading

### Standard Features

- 0.91 m x 2.44 m low mount platform
- Side entry with drop bar mid rail
- Multiple function operation
- Full proportional drive joystick control with integral thumb steer switch
- Full proportional main boom and swing joystick control
- Variable speed dial control for telescope, platform rotate and tower
- 2.44 m articulating jib
- JibPLUS® with 4 way axis jib including 125 degree horizontal motion
- Powered side stow on jib
- 180 degree powered platform rotator
- Platform console machine status light panel<sup>1</sup>
- Load sensing system
- AC power cable to platform
- Deutz TCD 3.6 L4 (74.4 Kw) (99.8HP) diesel engine
- Gull-wing turntable hoods
- Swing-out engine tray
- Spark arresting type muffler
- Control ADE® - (Advanced Design Electronics System)
- Adjustable swing drive
- Hydrostatic transmission
- Four wheel drive
- Four wheel steer/Two Wheel Steer/Crab Steer
- Horn
- Selectable dual platform capacity system (230kg/450kg)
- QuikStik® boom design feature
- Drive-out extending axles
- 5 degree tilt alarm and indicator light
- 445/50D710 24 ply foam filled
- 445/50D710 foam filled lug tread tyres
- Lifting/tie down lugs
- Hour Meter
- Ground control selector switch with key lock
- Load Sensing Hydraulics
- Skyguard without beacon
- 12V-DC auxiliary power

### Standard Specifications

- |                      |                               |
|----------------------|-------------------------------|
| • Diesel Engine      | Deutz TCD 3.6 L4 (74.4 kW)    |
| • Fuel Tank Capacity | 170 L                         |
| • Hydraulic System   | 352 L                         |
| • Auxiliary Power    | 12V DC                        |
| • Tyres              | 445/50D710 24 ply Foam-Filled |

### Accessories & Options

- 0.91 m x 1.83 m low mount platform
- 0.76 m x 0.91 m low mount platform, rear entry<sup>7</sup>
- Tri entry 0.91 m x 1.83 m low mount platform
- Side entry with inward swing gate
- 13 mm air line to platform
- On-board 4,000W generator
- SkyPower® package 7,500 watt on-board generator
- SkyWelder® package 250 amp welder in the platform<sup>3</sup>
- SkyGlazier® package glass and panel tray
- Nite-Bright® package<sup>4</sup>
- All motion alarm
- Light package<sup>5</sup>
- Platform worklights
- Head and tail lights
- Flashing amber beacon
- Plugs and sockets
- Hostile environment package<sup>6</sup>
- Hydraulic oil cooler
- Skyguard with beacon
- Soft Touch Proximity System
- Corner Storage tray
- ClearSky Locate
- ClearSky CAN

<sup>1</sup> Provides indicator lights at platform control console for system distress, low fuel, 5 degree tilt light, and foot switch status.

<sup>2</sup> Low oil pressure and high coolant temperature alarms with shut-down enabled/disabled by analyser.

<sup>3</sup> Available when integrated with the SkyPower™ package.

<sup>4</sup> Consists of six 40-watt lights, four turntable mounted lights and two platform mounted lights.

<sup>5</sup> Includes platform mounted work lights and head & tail lights.

<sup>6</sup> Includes console cover, boom wipers and cylinder bellows.

<sup>7</sup> Available only with drop bar type entry

# Model 1500AJP

## ARTICULATING BOOM LIFTS

### Performance

• Working Height	48.15 m
• Platform Height	46.15 m
• Horizontal Outreach	23.55 m
• Working Outreach **	24.20 m
• Up and Over Height	18.40 m
• Swing	360° (Continuous)
• Platform Capacity (Restricted)	450 kg
• Platform Capacity (Unrestricted)	270 kg
• Platform Rotator (Hydraulic)	180°
• Jib - Overall Length	2.44 m
• Jib - Range of articulation	130° Vertical (+75°/-55°)
• JibPLUS® - Range of Articulation	125° Horizontal
A. Platform Size	0.91 m x 2.44 m
B <sup>1</sup> . Overall Width (Axles Retracted)	2.50 m
B <sup>2</sup> . Overall Width (Axles Extended)	5.00 m
C. Tailswing (working condition)	0.70 m
D. Stowed Height	3.10 m
E <sup>1</sup> . Stowed Length	15.10 m
E <sup>2</sup> . Transport length	12.10 m
F. Wheelbase	4.60 m
G. Ground Clearance	0.30 m
• Machine weight *	26,027 kg
• Maximum Ground Bearing Pressure	8.6 kg/cm <sup>2</sup> - TBC
• Drive Speed 2WD	4.5 km/h 2WD/4WD
• Gradeability 2WD	40% 2WD/4WD
• Axle Oscillation	0.30 m
• Turning Radius – Inside	7.10 m (Axles Retracted) 2.30 m (Axles Extended)
• Turning Radius – Outside	9.50 m (Axles Retracted) 6.60 m (Axles Extended)



\* Certain options or country standards may increase weight and/or dimensions.  
\*\* Incl. 0.65 m outreach beyond platform

### Reach Diagram

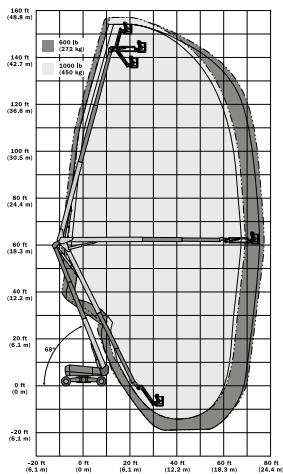

### Dimensions

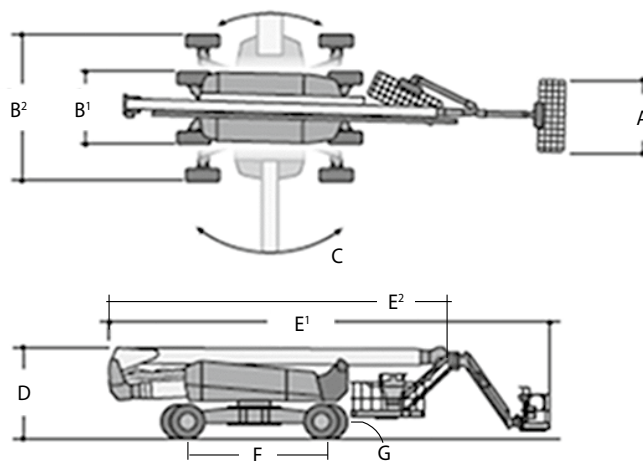

### IMPORTANT

JLG is continually researching and developing products and reserves the right to make modifications without prior notice. All data in this document is indicative. Certain options or country standards will increase weight. Specifications may change to meet country standards or with the addition of optional equipment.

Due to continuous product improvements, JLG Industries reserves the right to make specification and/or equipment changes without prior notification.



### JLG EMEA BV

Polaris Avenue 63  
2132 JH Hoofddorp  
The Netherlands  
Phone: +31 (0)23 565 5665  
[www.jlg.com](http://www.jlg.com)

An Oshkosh Corporation Company