

JERR-DAN[®]

Operation And Safety Manual

Original Instructions

Keep this manual with machine at all times.

CARGO HAULER

SN 0220019825 to Present

5376000234

December 1, 2019

JERR-DAN[®]

An Oshkosh Corporation Company

 **WARNING**

Operating, servicing and maintaining this vehicle or equipment can expose you to chemicals including engine exhaust, carbon monoxide, phthalates, and lead, which are known to the State of California to cause cancer and birth defects or other reproductive harm. To minimize exposure, avoid breathing exhaust, do not idle the engine except as necessary, service your vehicle or equipment in a well-ventilated area and wear gloves or wash your hands frequently when servicing. For more information go to www.P65Warnings.ca.gov.

REVISION LOG

December 1, 2019 - A - Original Issue of Manual.

Read This First

This manual provides Operational and Safety information for the Standar Duty Cargo Hauler. Read this manual and the Operation and Safety Manual provided with other equipment thoroughly prior to starting operation.

This manual is a very important tool! Keep it with the machine at all times.

The purpose of this manual is to provide owners, users, and operators with the precautions and operating procedures essential for the safe and proper machine operation for its intended purpose.

Due to continuous product improvements, Jerr-Dan Corporation reserves the right to make specification changes without prior notification. Contact Jerr-Dan Corporation for updated information.

OPERATOR QUALIFICATIONS

The operator of the machine must not operate the machine until this manual has been read, training is accomplished and operation of the machine has been completed under the supervision of an experienced and qualified operator.

Operators of this equipment must possess a valid, applicable driver's license, be in good physical and mental condition, have normal reflexes and reaction time, good vision and depth perception and normal hearing. Operator must not be using medication which could impair abilities nor be under the influence of alcohol or any other intoxicant during the work shift.

In addition, the operator must read, understand and comply with instructions contained in the following material furnished with the equipment:

- This Operation & Safety Manual
- All instructional decals and plates
- Any optional equipment instructions furnished
- Commercial vehicle's Operation & Maintenance Manuals

The operator must also read, understand and comply with all applicable Employer, Industry and Governmental rules, standards and regulations.

MODIFICATIONS

Any modification to this machine must be approved by Jerr-Dan.

HAZARD CLASSIFICATION SYSTEM

SAFETY ALERT SYSTEM AND SAFETY SIGNAL WORDS



This is the Safety Alert Symbol. It is used to alert to the potential personal injury hazards. Obey all safety messages that follow this symbol to avoid possible injury or death.



Indicates an imminently hazardous situation. If not avoided, will result in serious injury or death. This decal will have a red background.



Indicates a potentially hazardous situation. If not avoided, could result in serious injury or death. This decal will have an orange background.



Indicates a potentially hazardous situation. If not avoided, may result in minor or moderate injury. It may also alert against unsafe practices. This decal will have a yellow background.



Indicates information or a comply policy that relates directly or indirectly to the safety of the personnel or protection of property.

Read This First

⚠ WARNING

This product must comply with all safety related bulletins. Contact Jerr-Dan Corporation or the local authorized representative for information regarding safety bulletins which may have been issued for this product.

NOTICE

Jerr-Dan Corporation sends safety related bulletins to the owner of record of this machine. Contact Jerr-Dan Corporation to ensure that the current owner of records are updated and accurate.

NOTICE

Jerr-Dan Corporation must be notified immediately in all instances where Jerr-Dan product have been involved in an accident involving bodily injury or death of personnel or when substantial damage has occurred to personal property on the Jerr-Dan product.

FOR:

- Accident Reporting and Product Safety Publications
- Current Owner Updates
- Questions Regarding Product Applications and Safety
- Standards and Regulations Compliance Information
- Questions Regarding Product Modifications

CONTACT:

Product Safety and Reliability Department
Jerr-Dan Corporation
13224 Fountainhead Plaza
Hagerstown, MD 21742
USA

or Your Local Jerr-Dan Office

In USA

Toll Free: 1-877-554-7233

Outside USA

Phone: 240-420-2661

Fax: 301-745-3713

E-mail

ProductSafety@Jerr-Dan.com

REPORTING SAFETY DEFECTS

If you believe that your vehicle has a defect which could cause a crash or could cause injury or death, you should immediately inform the National Highway Traffic Safety Administration (NHTSA) in addition to notifying Jerr-Dan Corporation.

If NHTSA receives similar complaints, it opens an investigation, and if it finds that a safety defect exists in a group of vehicles, it may order a recall and remedy campaign. However, NHTSA cannot become involved in individual problems between you, your dealer, or Jerr-Dan Corporation.

To contact NHTSA, you may call the Vehicle Safety Hotline toll-free at 1-888-327-4236 (TTY: 1-800-424-9153); go to <http://www.safercar.gov>; or write to:

Administrator
NHTSA
400 Seventh Street S.W.
Washington, DC 20590

You can also obtain other information about motor vehicle safety from <http://www.safercar.gov>.

THIS PAGE IS INTENTIONALLY LEFT BLANK

TABLE OF CONTENTS

Revision Log

Read This First

Operator Qualifications.....	b
Modifications.....	b
Hazard Classification System.....	c
Safety Alert System and Safety Signal Words.....	c
Reporting Safety Defects.....	e

Table of Contents

Section 1 - General Safety Practices

1.1 General.....	1-1
1.2 Pre-Operation.....	1-2
Operator Training and Knowledge.....	1-2
Electrical Hazards.....	1-3
Crush and Collision Hazards.....	1-4
Falling Load Hazards.....	1-5
Uncontrolled Towed Load Hazards.....	1-5
Fall Hazards.....	1-6
Tip-Over Hazards.....	1-6
Chemical Hazards.....	1-7
Battery Hazards.....	1-8
Personal Protective Equipment.....	1-8
Weather Conditions.....	1-9
Vehicle Equipment Damage.....	1-9

Section 2 - Pre-Operation and Inspection

2.1 Pre-Operation Check And Inspection.....	2-1
2.2 Decals.....	2-2
2.3 Walk-Around Inspection.....	2-8
2.4 Operational Checks.....	2-11
Operational Check.....	2-11

Section 3 - Controls & Indicators

3.1 General.....	3-1
3.2 Controls.....	3-2
Left Hand - Side Control Station.....	3-2
Right Hand - Side Control Station.....	3-2

Section 4 - Operation

4.1 Tilting the Deck/Loading.....	4-2
4.2 Tilting the Deck/Unloading.....	4-8
4.3 Securing vehicle.....	4-13
4.4 "IRL" Wheel Lift Operation.....	4-16
4.5 "L" Arm Grid Operation.....	4-23
4.6 "T37" Pivoting Grid Operation.....	4-25
4.7 Tie-Down Straps - L-Arm Grid	4-27
4.8 Tie-Down Straps - "T37" Grid	4-29

Table of Contents

Section 5 - Emergency Procedures

5.1	Electric/Hydraulic Failure	
	Raising/Lowering/Extending/Retracting Deck.....	5-1
5.2	Engine Failure	
	Raising/Lowering/Extending/Retracting Deck.....	5-2

Section 6 - Maintenance

6.1	Introduction.....	6-1
6.2	Maintenance And Lubrication.....	6-2
6.3	fastener torque specifications.....	6-3
6.4	Oils And Greases.....	6-4
6.4	Lubrication Chart.....	6-5
	Lubrication Points.....	6-6
6.5	Trouble Shooting.....	6-8
	Hydraulic System.....	6-8
	P.T.O. Functioning Improperly.....	6-9
	Hydraulic Pump.....	6-9

Section 7 - Specifications

7.1	Product Specifications.....	7-1
	6Ton Standard Duty Cargo hauler.....	7-1
	6Ton Standard Duty XLP Cargo hauler.....	7-3
	Truck Chassis.....	7-5
7.2	Capacities.....	7-6

Inspection, Maintenance and Repair Log

Transfer Of Ownership

SECTION 1 - GENERAL SAFETY PRACTICES

1.1 GENERAL

This section outlines the necessary precautions for proper and safe vehicle operation and maintenance. For proper vehicle, it is mandatory that a daily routine is established based on the content of this manual. A maintenance program, using the information provided in this manual must also be established by a qualified person and followed to ensure the vehicle is safe to operate.

The owner/user/operator of the vehicle must not operate the vehicle until this manual has been read, training is accomplished, and operation of the vehicle has been completed under the supervision of an experienced and qualified operator.

There may be times the vehicle may be exposed to direct contact with the public such as parades, charitable fundraisers, etc. Before allowing anyone other than a trained and experienced company employee near your vehicle, consult with the company safety officer and plan for safety.

If there are any question with regard to safety, training, inspection, maintenance, application, and operation, please contact Jerr-Dan Corporation.

WARNING

Failure to comply with the safety precautions listed in this manual could result in vehicle damage, property damage, personal injury or death.

Section 1 - General Safety Practices

1.2 PRE-OPERATION

OPERATOR TRAINING AND KNOWLEDGE

- Read and understand this manual before operating the vehicle.



- Do not operate this vehicle until complete training is performed by authorized persons.
- Only authorized and qualified personnel can operate the vehicle.
- Read, understand, and obey all DANGERS, WARNINGS, CAUTIONS, and operating instructions on the vehicle and in the manual.
- Use the vehicle in a manner which is within the scope of its intended application set by Jerr-Dan.
- All operating personnel must be familiar with the emergency operation of the vehicle as specified in this manual.
- Read, understand, and obey all applicable employer, local, and government regulations as they pertain to the operation of the vehicle.
- Become familiar with the loads that your unit can safely transport without exceeding the structural rating of the Jerr-Dan unit or the gross axle weight ratings, gross vehicle weight rating, and the gross combined vehicle weight rating of your chassis.

Section 1 - General Safety Practices

ELECTRICAL HAZARDS

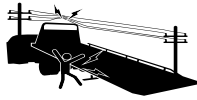

- This vehicle is not insulated and does not provide protection from contact or being near electrical current. This includes lightning and lightning strikes.
- NEVER operate the vehicle in an area where overhead power lines, overhead or underground cables, or other power sources may exist without ensuring the appropriate power utility company de-energizes the lines.
- Always check for power lines before raising the deck.
- Look up and use light to search for power lines in the dark.
- Allow for vehicle movement and electrical line swaying.
- Do not step off or touch a charged vehicle.
- Maintain a clearance of at least 10 ft (3m) between any part of the vehicle from any electrical line or apparatus carrying up to 50,000 volts. Refer to the Minimum Approach Distance (MAD) chart. One foot additional clearance is required for every additional 30,000 volts or less.

Minimum Approach Distance (M.A.D.)

Voltage Range (Phases to Phase)	MINIMUM APPROACH DISTANCE in Feet (Meters)
0 to 50KV	10 (3)
Over 50KV to 200KV	15 (5)
Over 200KV to 350KV	20 (6)
Over 350KV to 500KV	25 (8)
Over 500KV to 750KV	35 (11)
Over 750KV to 1000KV	45 (14)

NOTE: This requirement shall apply except where employer, local or government regulations are more stringent.

- The minimum approach distance may be reduced if insulating barriers are installed to prevent contact, and the barriers are rated for the voltage of the line being guarded. These barriers shall not be part of (or attached to) the truck. The minimum approach distance shall be reduced to a distance within the designed working dimensions of the insulating barrier. This determination shall be made by a qualified person in accordance with the employer, local, or governmental requirements for work practices near energized equipment.

Section 1 - General Safety Practices

DANGER

Do not maneuver vehicle or personnel inside prohibited zone (MAD). Assume all electrical parts and wiring are energized unless known otherwise

CRUSH AND COLLISION HAZARDS



- Ensure to stay clear of oncoming traffic. Driver side and passenger side controls are standard on your Jerr-Dan carrier.
- Keep clear of rear stabilizer
- Stay clear of equipment to avoid crushing injury.
- Always use jack stands to support the deck and/or towbar/wheel-lift before working underneath a lifted load.
- Warn personnel not to work, stand, or walk under a raised deck. Position barricades if necessary.
- Set parking brake and chock wheels of the vehicle when connecting equipment.
- KEEP ALERT! Avoid distractions during any operating sequences.
- Be aware of height clearances when travelling.



- Look out for and avoid other personnel, machinery, vehicles and obstructions in the area when driving the truck. Use a spotter if you do not have a clear view.

Section 1 - General Safety Practices

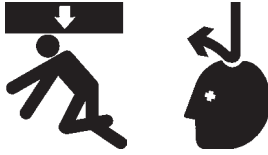

When opening tool compartments:

- Loose items may shift during transport. Properly secure items when not in use
- Ensure all tool compartment doors are properly closed prior to transport.

FALLING LOAD HAZARDS

- Keep people away during operation.
- Never exceed capacity of rigging.
- NEVER work behind the truck with equipment on the deck unless the equipment is secured at the front of the deck.

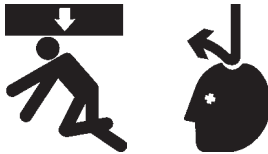

- Block up the deck before performing any service or maintenance work under the deck.
- Approved head gear must be worn during operations.

UNCONTROLLED TOWED LOAD HAZARDS

- Always know the weight distribution of your load and ensure you are within your truck's Gross Axle Weight Rating (GAWR), Gross Vehicle Weight Rating (GVWR) and Gross Combination Weight Rating (GCWR) as well as any federal or state roading regulation. In addition, be aware of your vehicle's overall loaded height to be sure that you are under the federal bridge law height of 13 feet 6 inches.
- DO NOT exceed GAWR's or GCWR of the chassis



Section 1 - General Safety Practices

- Use two (2) safety chains and four (4) tie down chains.
- Check chain tension periodically while in transit.
- Always retract towbar as close as possible.
- Ensure safety chains are properly attached from tow vehicle to towed equipment.
- After you have placed equipment on the carrier for towing, do not start the tow until tie-down straps and chains have been installed per the equipments recommended tie-down points.
- Place the load evenly on the deck. Do not concentrate the load on one section of the deck, to the rear of the truck axles, or use towbar without a load on the deck.
- NEVER exceed towbar ratings. Overloading can cause unsafe steering and braking conditions.
- Secure equipment to the deck at both the front and rear before the vehicle is driven.
- Always use both wheel straps on wheel lift towbar.

FALL HAZARDS

- DO NOT carry riders outside the cab. Riders could fall off the vehicle.
- NEVER allow riders in the towed equipment during lifting or transport.
- Only use approved ladders and grab handles and steps provided on the left side of the vehicle when accessing the deck. Always maintain 3-point contact, using two hands and one foot or two feet and one hand, when mounting or dismounting. These surfaces can become slippery, ensure to keep them and footwear clean and free of debris.

TIP-OVER HAZARDS

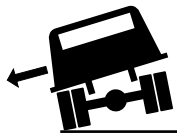

- Set up on firm surface only.
- Deploy rear bumper onto proper firm surface.
- Ensure truck is level prior to any operations.
- Make sure that equipment load is centered side to side.

CHEMICAL HAZARDS

Exhaust Fumes

- DO NOT operate vehicle in an enclosed area without proper ventilation.
- DO NOT operate the vehicle in hazardous environments unless approved for that purpose by Jerr-Dan and site owner. Sparks from the electrical system and the engine exhaust can cause an explosion.

Flammable Fuel



- DO NOT fill the fuel tank or service the fuel system near an open flame, sparks or smoking materials. Engine fuel is flammable and can cause a fire and/or explosion.

Hydraulic Fluid



- DO NOT attempt to repair or tighten any hydraulic hoses or fittings while the engine is running or when the hydraulic system is under pressure.
- Stop engine and relieve trapped pressure. Fluid in the hydraulic system is under pressure and can penetrate the skin.
- DO NOT use your hand to check for leaks. Use a piece of cardboard or paper to search for leaks. Wear gloves to protect hands from spraying fluid.

Section 1 - General Safety Practices

BATTERY HAZARDS



- Battery fluid is highly corrosive. Avoid contact with skin and clothing at all times.
- Keep sparks, flames, and lighted materials away from batteries.
- Charge batteries only in a well ventilated area.
- Wear proper eye protection when servicing battery.

PERSONAL PROTECTIVE EQUIPMENT



- Use personal protective equipment when working on or around this vehicle.
- Remove rings, watches, jewellery, neckwear or other items that can catch in equipment.
- Wear :
 - o Snug fitting and sturdy long-sleeve shirt and long pants. Avoid loose fitting clothes.
 - o Sturdy gloves.
 - o Approved eye protection.
 - o Steel toed boots.
 - o Approved head gear.
 - o Approved hearing protection.

WEATHER CONDITIONS

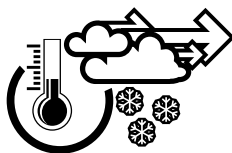

- Be aware of the wind conditions. Wind may cause load to swing or shifting of load.
- If using in freezing conditions, you must be alert to possibility of ice forming on the device. Use Caution when extending and retracting towbar, and stabilizer. In addition use caution when opening/closing body panels.
- Hydraulic cylinders are subject to thermal expansion and contraction. This may result in changes to the deck, stabilizer and/or towbar position while the vehicle is stationary. Factors affecting thermal movement can include the length of time the vehicle is stationary, hydraulic oil temperature, and ambient air temperature.

VEHICLE EQUIPMENT DAMAGE

- Ensure vehicle is positioned in an area free from overhead obstructions. Keep a safe working distance from overhead power lines, bridges, road signs and other objects.
- Do not use a vehicle that has not been properly maintained. Make sure mounting bolts are tight and moving parts are lubricated.
- Do not tow a vehicle on its drive wheels unless steps have been taken to protect its transmission and differential. Follow the recommendations of the vehicle manufacturer.
- Never attach the chain hooks in such a way as to damage brake lines or other functional parts.
- Make sure all brakes and locks are properly set on the vehicle.
- Do not operate the engine faster than recommended. Excessive speeds can damage PTO, and hydraulic pumps.
- Deck approach tip and subframe bumper may damage paved surfaces.
- Do not travel with the PTO engaged. Damage to the vehicle transmission and hydraulic components will occur. Engage the PTO only when operating the hydraulic controls.
- Always put the rear bumper on the ground to support the body and truck frame.
- Make sure deck is in the locked position before travelling.

Section 1 - General Safety Practices

- Do not use vehicle as a ground when performing any welding operations.
- Store L-Arms when not in use. NEVER drive with the L-Arms in the wheel grids.
- Use CAUTION on air bag equipped vehicles when using a push bumper. Avoid sudden impact which could activate the air bag sensor while pushing.

SECTION 2 - PRE-OPERATION AND INSPECTION

2.1 PRE-OPERATION CHECK AND INSPECTION

Note: Complete all required maintenance before operating unit.

⚠ WARNING

FALL HAZARD. Use extreme caution when checking items beyond your normal reach. Use an approved ladder.

The pre-operation check and inspection, performed at beginning of each work shift or at each change of operator, should include the following:

1. **Cleanliness** - Check all surfaces for leakage (oil, fuel or battery fluid) or foreign objects. Report any leakage to the proper maintenance personnel.
2. **Structure** - Inspect the vehicle structure for dents, damage, weld or parent metal cracks or other discrepancies.
3. **Safety Decals Placards** - Ensure all safety decals are legible and in place. Clean or replace as required. See page 2-2 for details.
4. **Operation and Safety Manual(s)** - Operation & Safety Manual(s) are in cab.
5. **Walk-Around Inspection** - See page 2-8 for details.
6. **Fluid Levels** - Check all fluids, including hydraulic oil. When adding fluids, refer to Section 6 - Maintenance and Lubrication and Section 7 - Specifications to determine proper type and intervals. Before removing filler caps or fill plugs, wipe all dirt and grease away from the ports. If dirt enters these ports, it can severely reduce component life.
7. **Attachments/Accessories** - Inspect all attachments for dents, damage, weld or parent metal cracks or other discrepancies. Inspect tie-down straps for cuts, frays or tears. Inspect chains for weld or parent metal cracks or other discrepancies.
8. **Operational Check** - Once the walk-around inspection is complete, perform a warm-up and operational check (see page 2-11) of all systems in an area free of overhead and ground level obstructions. See Section 3 - Controls and Indicators for more specific operating instructions.

⚠ WARNING

If the vehicle does not operate properly, immediately bring the vehicle to a stop, and stop the engine. Determine cause and correct before continued use.

Section 2 : Pre-Operation and Inspection

2.2 DECALS

Ensure all **DANGER**, **WARNING**, **CAUTION** and instructional decals and proper capacity charts are legible and in place. Clean and replace as required.

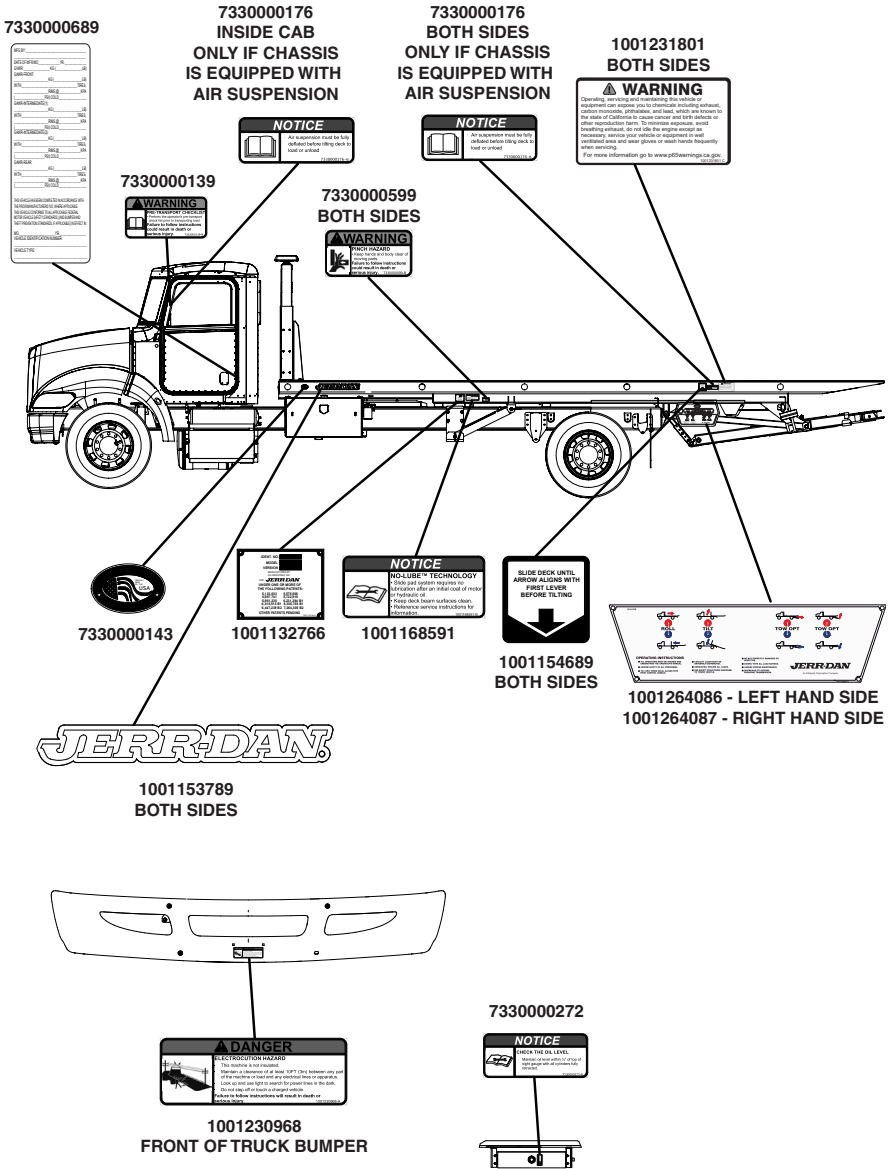

HYDRAULIC TANK

Section 2 : Pre-Operation and Inspection

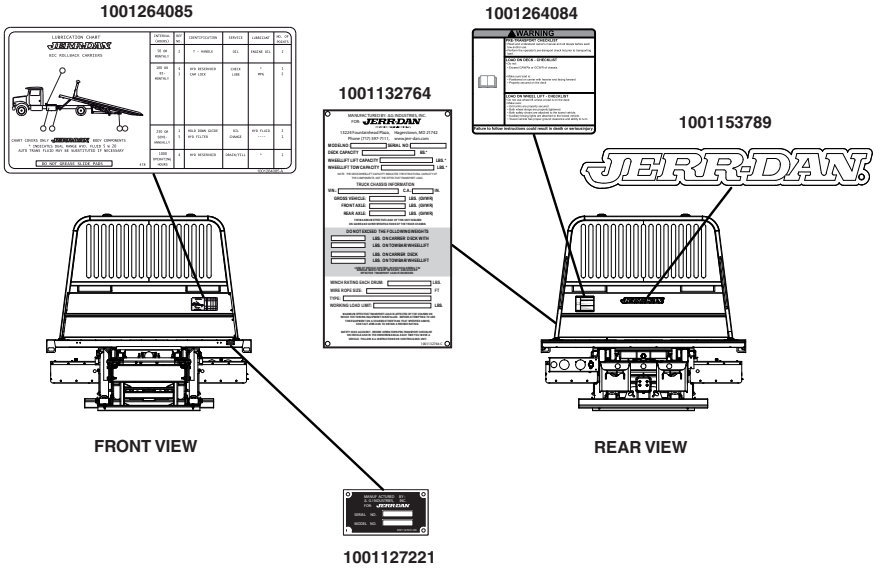

DELUXE FIXED HEIGHT DECK MOUNTED HEADBOARD

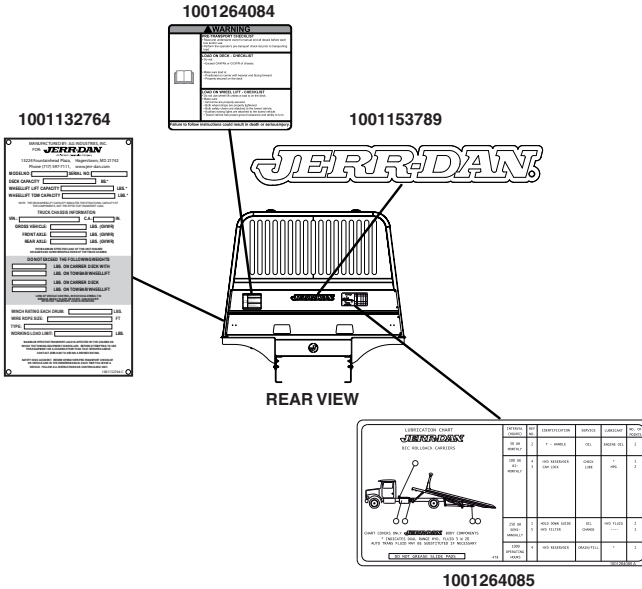

DELUXE FIXED HEIGHT FRAME MOUNTED HEADBOARD

Section 2 : Pre-Operation and Inspection

1001264085

ITEM NO.	DESCRIPTION	QTY	REVISION	DATE	BY
1001264085	1001264085	1	1	10/10/10	1001264085

IMPORTANT: READ INSTRUCTIONS AND SAFETY WARNINGS CAREFULLY.

DO NOT OPERATE THIS EQUIPMENT UNLESS YOU ARE TRAINED AND QUALIFIED TO DO SO. ALWAYS WEAR YOUR SEATBELT AND SAFETY BELT. ALWAYS WEAR YOUR SAFETY BELT AND SAFETY BELT. ALWAYS WEAR YOUR SAFETY BELT AND SAFETY BELT.

1001264084

WARNING

READ INSTRUCTIONS AND SAFETY WARNINGS CAREFULLY.

DO NOT OPERATE THIS EQUIPMENT UNLESS YOU ARE TRAINED AND QUALIFIED TO DO SO. ALWAYS WEAR YOUR SEATBELT AND SAFETY BELT. ALWAYS WEAR YOUR SAFETY BELT AND SAFETY BELT. ALWAYS WEAR YOUR SAFETY BELT AND SAFETY BELT.

1001132764

WARNING

READ INSTRUCTIONS AND SAFETY WARNINGS CAREFULLY.

DO NOT OPERATE THIS EQUIPMENT UNLESS YOU ARE TRAINED AND QUALIFIED TO DO SO. ALWAYS WEAR YOUR SEATBELT AND SAFETY BELT. ALWAYS WEAR YOUR SAFETY BELT AND SAFETY BELT. ALWAYS WEAR YOUR SAFETY BELT AND SAFETY BELT.

1001153789

JERR-DAN

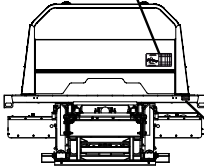

FRONT VIEW

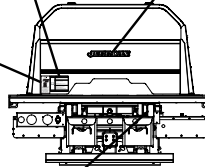

REAR VIEW



1001127221



1001132766

ADJUSTABLE HEIGHT DECK MOUNTED HEADBOARD

1001264084

WARNING

READ INSTRUCTIONS AND SAFETY WARNINGS CAREFULLY.

DO NOT OPERATE THIS EQUIPMENT UNLESS YOU ARE TRAINED AND QUALIFIED TO DO SO. ALWAYS WEAR YOUR SEATBELT AND SAFETY BELT. ALWAYS WEAR YOUR SAFETY BELT AND SAFETY BELT. ALWAYS WEAR YOUR SAFETY BELT AND SAFETY BELT.

1001153789

JERR-DAN

1001132764

WARNING

READ INSTRUCTIONS AND SAFETY WARNINGS CAREFULLY.

DO NOT OPERATE THIS EQUIPMENT UNLESS YOU ARE TRAINED AND QUALIFIED TO DO SO. ALWAYS WEAR YOUR SEATBELT AND SAFETY BELT. ALWAYS WEAR YOUR SAFETY BELT AND SAFETY BELT. ALWAYS WEAR YOUR SAFETY BELT AND SAFETY BELT.

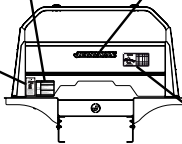

1001264085

ITEM NO.	DESCRIPTION	QTY	REVISION	DATE	BY
1001264085	1001264085	1	1	10/10/10	1001264085

IMPORTANT: READ INSTRUCTIONS AND SAFETY WARNINGS CAREFULLY.

DO NOT OPERATE THIS EQUIPMENT UNLESS YOU ARE TRAINED AND QUALIFIED TO DO SO. ALWAYS WEAR YOUR SEATBELT AND SAFETY BELT. ALWAYS WEAR YOUR SAFETY BELT AND SAFETY BELT. ALWAYS WEAR YOUR SAFETY BELT AND SAFETY BELT.

1001264085

ADJUSTABLE HEIGHT FRAME MOUNTED HEADBOARD

Section 2 : Pre-Operation and Inspection

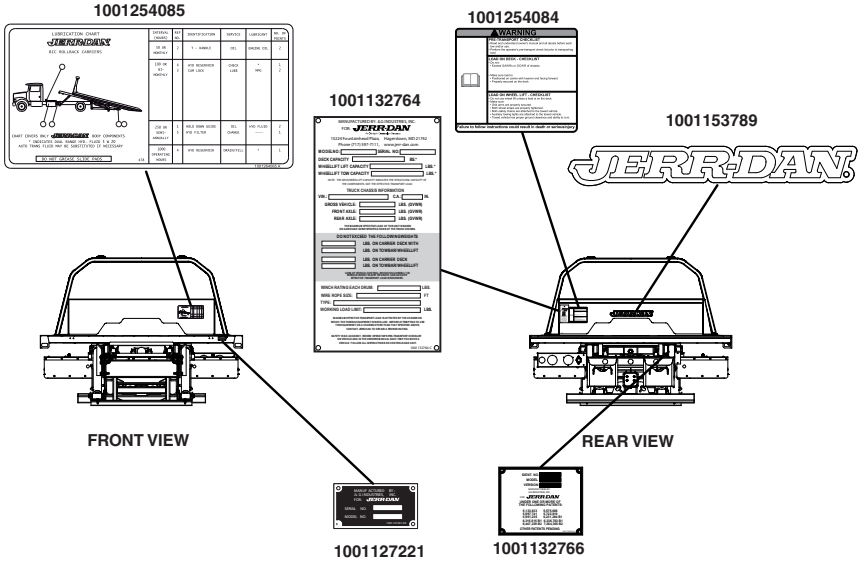

FIXED HEIGHT DECK MOUNTED HEADBOARD

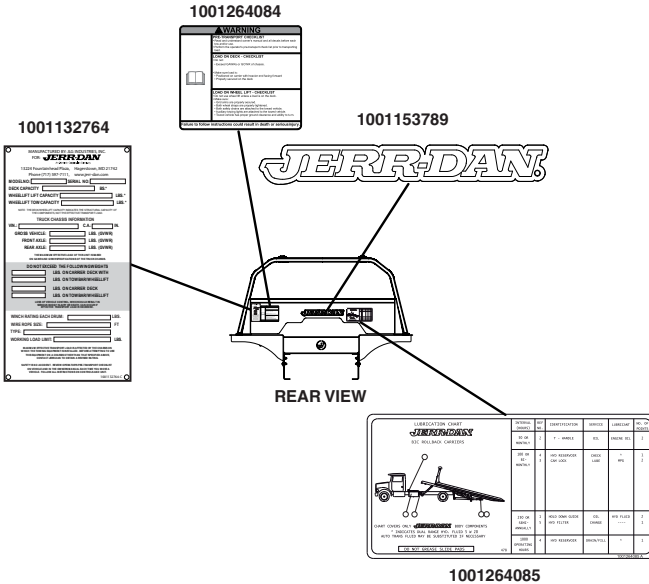

FIXED HEIGHT FRAME MOUNTED HEADBOARD

Section 2 : Pre-Operation and Inspection

7330000599
BOTH
LH AND RH SIDES

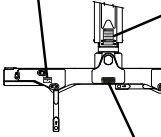

7330000684



7330000683
BOTH
LH AND RH SIDES

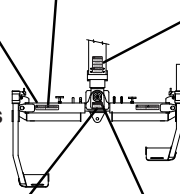

7330000060
IF EQUIPPED



HYDRAULIC GRID WHEEL LIFTS

3,000 LB T-37 WHEEL GRIDS

7330000683
BOTH
LH AND RH SIDES

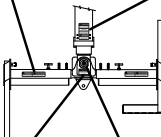
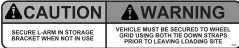

7330000060
IF EQUIPPED

7330000684



7330000609



3,000 LB L-ARM WHEEL GRIDS

WHEEL GRID OPTIONS

Section 2 : Pre-Operation and Inspection

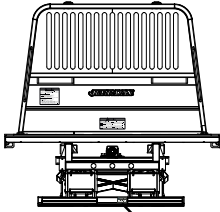

⚠ WARNING
PINCH HAZARDS
AND MOVING PARTS
KEEP CLEAR OF THIS AREA

7330000599

REAR DOCK STABILIZER
IF EQUIPPED

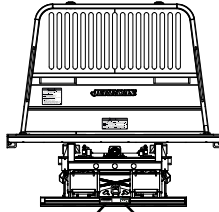

⚠ WARNING
DO NOT EXCEED TOW OPTION
CAPACITY. OVERLOADING MAY
RESULT IN UNSTEERING
AND/OR BRAKING CONDITIONS.

⚠ WARNING
PINCH HAZARDS
AND MOVING PARTS
KEEP CLEAR OF THIS AREA

7330000274 7330000599

REAR DOCK STABILIZER
WITH REESE HITCH
IF EQUIPPED

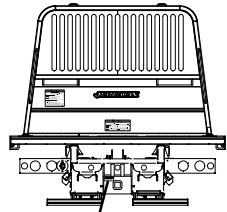

⚠ WARNING
DO NOT EXCEED TOW OPTION
CAPACITY. OVERLOADING MAY
RESULT IN UNSTEERING
AND/OR BRAKING CONDITIONS.

7330000274

STATIONARY REESE HITCH
AND PINTLE HITCH
IF EQUIPPED

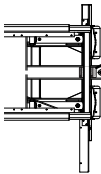

⚠ WARNING
DO NOT EXCEED TOW OPTION
CAPACITY. OVERLOADING MAY
RESULT IN UNSTEERING
AND/OR BRAKING CONDITIONS.

PINCH HAZARDS
AND MOVING PARTS
KEEP CLEAR OF THIS AREA

TOWED VEHICLE MUST BE
CONNECTED TO ROOF SUBFRAME
WITH SAFETY CHAINS

⚠ CAUTION
FULLY RETRACT TOW OPTION
SCAM TO FIVE DAMAGE
DURING OPERATION OF OTHER
CARRIER FUNCTIONS

7330000684

⚠ WARNING
DO NOT EXCEED TOW OPTION
CAPACITY

TOW BAR
WITH PINTLE HITCH OR
BALL HITCH
(IF EQUIPPED)

7330000391

STABILIZER OPTIONS

Section 2 : Pre-Operation and Inspection

2.3 WALK-AROUND INSPECTION

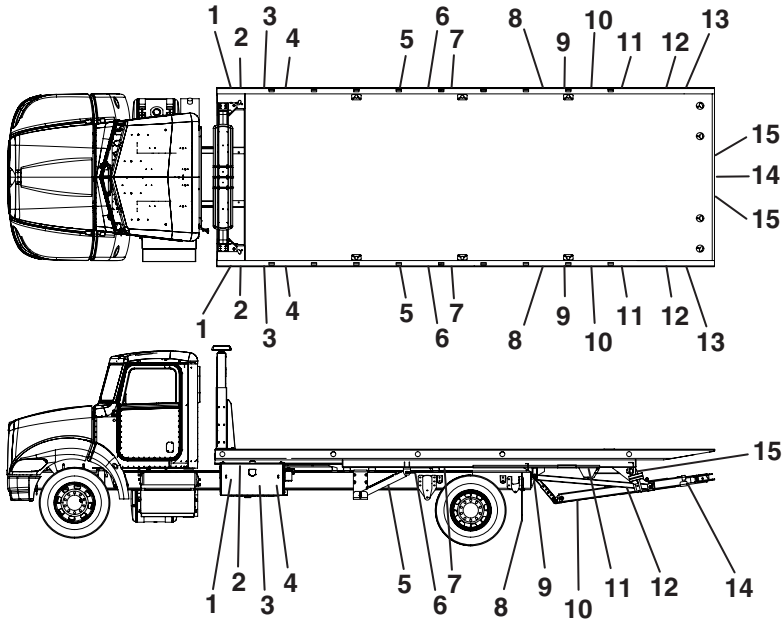

Begin your walk-around inspection at item 1, as noted below checking each item in sequence.

INSPECTION NOTE: On all components, make sure there are no loose or missing parts, that they are securely fastened and no visible leaks or excessive wear exists in addition to any other criteria mentioned. Inspect all structural members for cracks, excessive corrosion and other damage.

WARNING

FALL HAZARD. Use extreme caution when checking items beyond your normal reach. Use an approved ladder.

CAUTION

All products are subject to age, wear and deterioration, all of which cause a reduction in the products breaking strength capacity. It is recommended that all products be regularly inspected to follow component manufacturer's recommendations. Any worn, deformed, misused or overloaded products must be replaced immediately.

Section 2 : Pre-Operation and Inspection

1. Deck Holddown System
 - a. Components undamaged
 - b. Holddowns secure
2. Folding Step(s) (If Equipped)
 - a. Components undamaged and operational
 - b. Secure
3. Hydraulic Tank
 - a. Hydraulic fluid level full
 - b. Hydraulic hoses undamaged, not leaking
4. Toolbox/Storage Compartment(s)
 - a. Components undamaged
 - b. Toolbox/Storage Compartment(s) secure
5. Tilt Cylinders
 - a. Hydraulic hoses undamaged, not leaking
 - b. Cylinder, not leaking
 - c. Pins, secure
 - d. Check for presence of grease
6. Subframe
 - a. Components undamaged
7. Rollback Cylinder
 - a. Hydraulic hoses undamaged, not leaking
 - b. Cylinder, not leaking
 - c. Pins, secure
8. Mud Flaps
 - a. Components undamaged
 - b. Mud Flaps secure
 - c. Mud Flaps are present

Section 2 : Pre-Operation and Inspection

9. Deck Pivot

- a. Components undamaged
- b. Pins, secure
- c. Check for presence of grease

10. Wheel-Lift/Tow Bar (If Equipped)

- a. Components undamaged
- b. Pins, secure

11. Controls

- a. Components and switches undamaged
- b. Hydraulic hoses and electric harnesses undamaged
- c. Valve and hydraulic hoses not leaking

12. Stabilizer Arms (If Equipped)

- a. Components undamaged
- b. Pins, secure
- c. Check for presence of grease

13. IRL/Stabilizer Cylinder(If Equipped)

- a. Hydraulic hoses undamaged, not leaking
- b. Cylinder, not leaking
- c. Pins, secure

14. Wheel-Lift/Tow Bar(If Equipped)

- a. Components undamaged
- b. Pins, secure

15. Chain Storage Boxes and Safety Chains

- a. Chain Storage Boxes undamaged
- b. Safety Chains are present
- c. Safety Chains are undamaged

2.4 OPERATIONAL CHECKS

OPERATIONAL CHECK

When engine warms, perform an operational check:

1. Service brake and parking brake operation.
2. Horn and back-up alarm. Must be audible from inside vehicle cab with engine running.
3. Hydraulic filter condition indicator.
4. Power-Take-Off operation.
5. Driver side and passenger side controlled functions - all functions operate smoothly and the controls return to the "Neutral Off" position.
6. All lighting systems, operational.
7. Emergency lighting operation.

THIS PAGE IS INTENTIONALLY LEFT BLANK

SECTION 3 - CONTROLS & INDICATORS

3.1 GENERAL

This section provides the necessary information needed to understand the control functions.

The controls inside the vehicle cab control the emergency lights, auxiliary lights and the Power Take Off. The Power Take Off provides a transfer of power from the transmission to a hydraulic pump to provide hydraulic power to the carrier hydraulics

The controls at the rear of the body on both the left hand side and right hand side control all of the carrier functions.

The carrier is also be supplied with various optional wireless remote controllers. The wireless remote controllers can be found inside the cab of the vehicle in the designated holder.

Note: *The manufacturer has no direct control over machine application and operation. The user and operator are responsible for conforming with good safety practices.*

Section 3 - Controls & Indicators

3.2 CONTROLS

LEFT HAND - SIDE CONTROL STATION

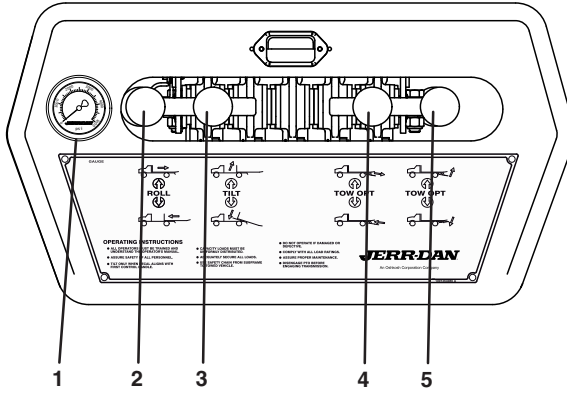



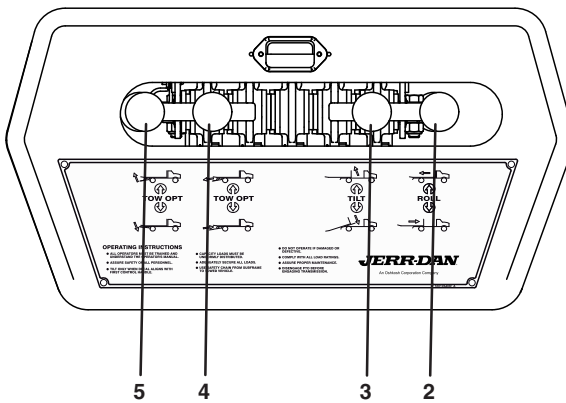











RIGHT HAND - SIDE CONTROL STATION



Section 3 - Controls & Indicators

1. Pressure Gauge : Indicates system hydraulic pressure
2. Deck Roll Control : Controls the deck roll - Forward/Back
3. Deck Tilt Control : Controls the deck tilt - Up/Down
4. Tow Option Control (If Equipped) : Controls the Tow Option - In/Out
5. Tow Option Control (If Equipped) : Controls the Tow Option - Up/Down.

	1	2	3	4	5
STANDARD DECK		 ROLL 	 TILT 		
TOWBAR OPTION		 ROLL 	 TILT 	 TOW OPT 	 TOW OPT 

THIS PAGE IS INTENTIONALLY LEFT BLANK

SECTION 4 - OPERATION

Operating controls for your carrier are conveniently located on the left hand side. Another set of controls are located on the right hand side.

 WARNING

CRUSH HAZARD. Always operate the controls from the side away from traffic.

Section 4 : Operation

4.1 TILTING THE DECK/LOADING

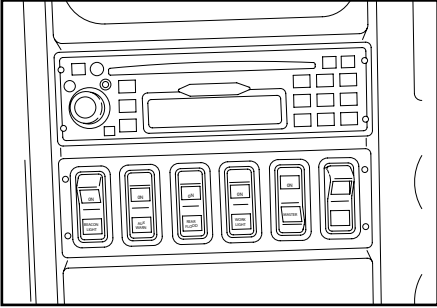

1. Turn on the body lights and any work lights, as necessary. (Switches are located on the switch panel in the dash).

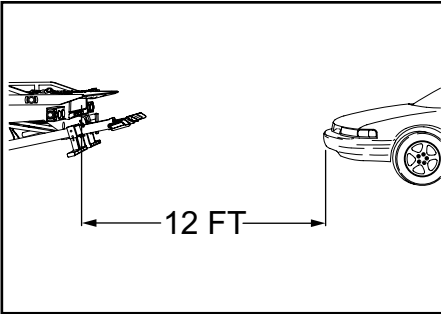

2. Position the rear of the carrier deck about 12 feet from the equipment you intend to load. Make sure the vehicle is in line with the equipment.

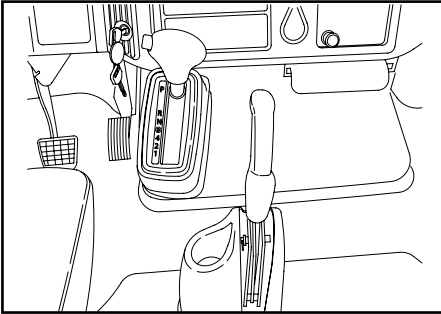

3. Place the carrier's transmission gear selector into Neutral or Park and set the parking brakes.

Section 4: Operation

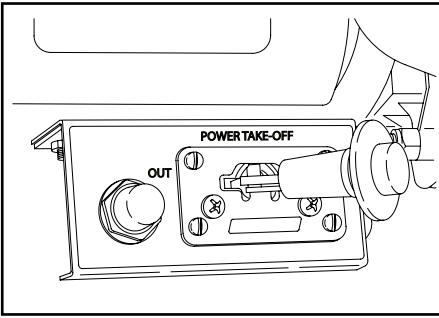

4. Engage the power take-off (PTO). Refer to PTO operator's manual.

NOTICE

NEVER TRAVEL WITH THE POWER TAKE OFF CONTROL ENGAGED. This could result in damage to the PTO unit and the recovery vehicle's transmission.

5. Adjust the electronic or manual throttle control to set the engine speed to approximately 1000-1200 R.P.M. Refer to chassis operator's manual for proper operation of the auxiliary throttle. If your chassis is equipped with the remote throttle up option from the chassis manufacturer there is no need to set the throttle up control in the cab because the throttle will automatically increase when any of the carrier hydraulic functions are operated.

NOTICE

Never exceed 1200 R.P.M. When your ready to travel, reset the engine idle to normal.

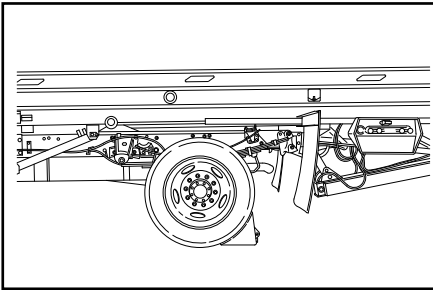

6. Block the carrier's rear tires with wheel chocks to prevent accidental carrier movement. Check the area around the carrier and the equipment to be loaded for obstructions or hazards.

Section 4 : Operation

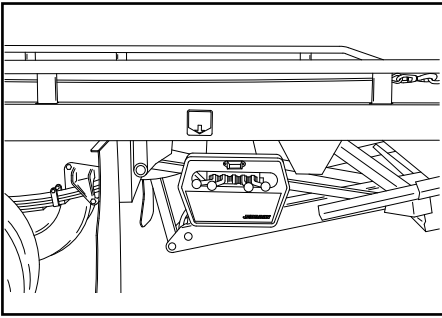

7. Slide the deck back. Align the arrow decal pointer on the side of the deck with the deck control switch in the control panel.

NOTICE

Tilting the deck too soon may cause damage to the mechanical hold down.

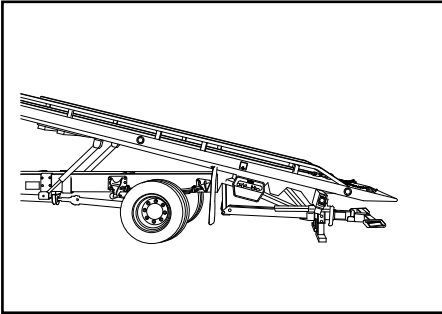

8. Raise the front of the deck until the rear bumper rests firmly on the ground.

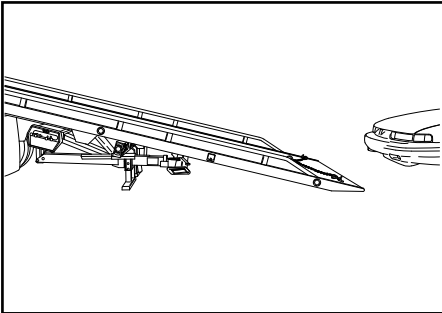

9. Slide the deck back again. Continue sliding the deck back until the approach plate makes firm contact with the ground. Make sure that the rear bumper and the approach plate are both in firm contact with the ground before loading so there is equal weight distribution between the rear bumper and the end of the deck.

10. Load vehicle onto deck.

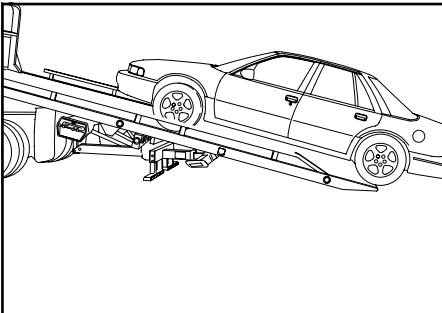

NOTICE

Make sure that the equipment is centered side to side.

Section 4: Operation

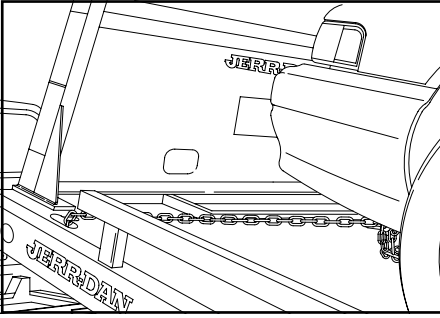

11. Secure the front of the vehicle to the deck.

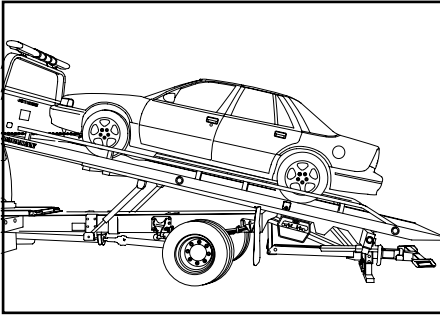

12. Lower the Rollback Control handle to move the deck forward. Align the arrow decal pointer on the side of the deck with the first control handle. Lowering the deck too late may cause damage to the mechanical hold down.

NOTICE

Lowering the deck too late may cause damage to the mechanical hold down.

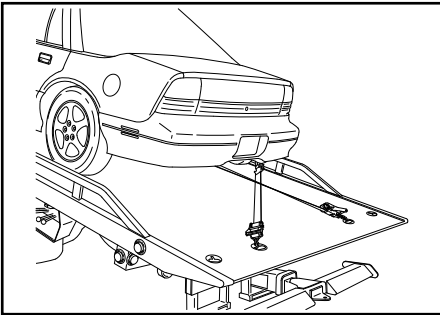

13. Secure the equipment to the rear of the deck..

⚠ WARNING

Always use approved tie downs per the equipment manufacturers instructions.

Section 4 : Operation

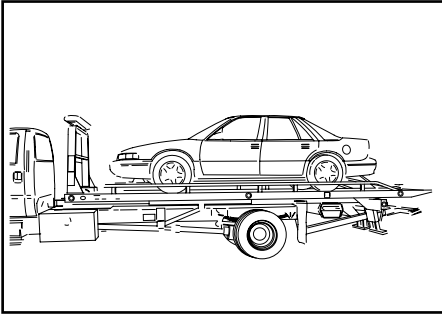

14. Once the vehicle is secured from movement in all directions, lower the Tilt Control handle and lower the front of the deck to the subframe.

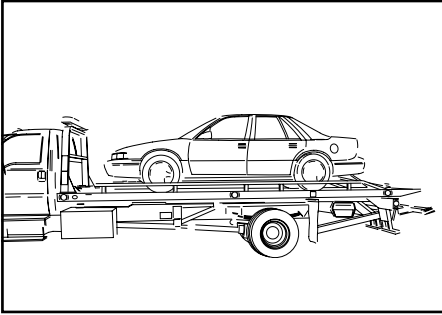

15. Lower the Rollback Control handle and move the deck completely forward until it engages the hold downs and into the transport position.

WARNING

Always use approved tie downs per the equipment manufacturer's instructions.

WARNING

Always refer to the Operator's Pre-Transport Checklist located on the headboard of the deck before transporting. Make sure you have followed all of the items on the list.

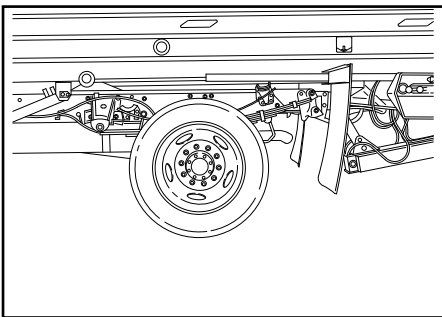

16. Remove the wheel chocks from the carrier's rear tires.

Section 4: Operation

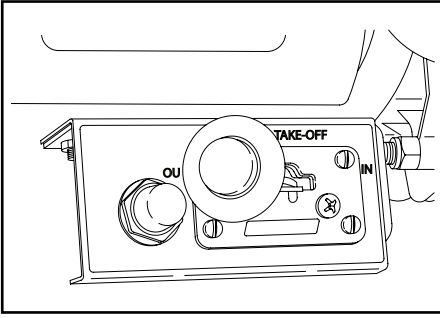

17. Disconnect the power take-off (PTO). Refer to PTO operator's manual.

NOTICE

NEVER TRAVEL WITH THE POWER TAKE OFF CONTROL ENGAGED. This could result in damage to the PTO unit and the recovery vehicle's transmission.

Section 4 : Operation

4.2 TILTING THE DECK/UNLOADING

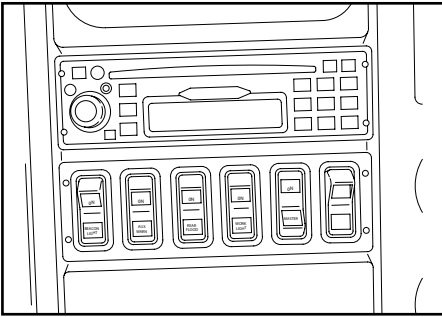

1. Turn on the body lights and any work lights, as necessary. (Switches are located on the switch panel in the dash).

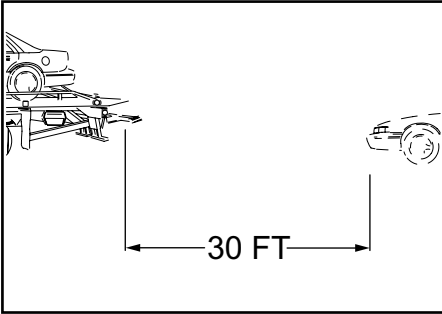

2. Position the rear of the carrier allowing significant area to unload the equipment.

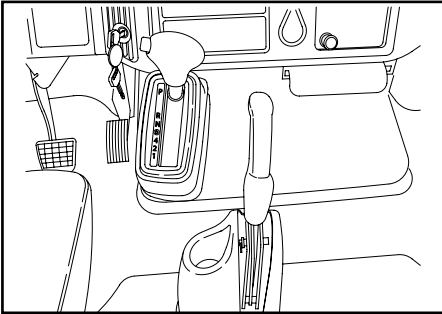

3. Place the carrier's transmission gear selector into Neutral or Park and set the parking brakes.

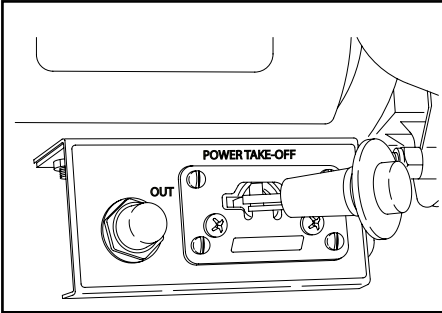

4. Engage the power take-off (PTO). Refer to PTO operator's manual.

NOTICE

NEVER TRAVEL WITH THE POWER TAKE OFF CONTROL ENGAGED. This could result in damage to the PTO unit and the recovery vehicle's transmission.

- Adjust the electronic or manual throttle control to set the engine speed to approximately 1000-1200 R.P.M. Refer to chassis operator's manual for proper operation of the auxiliary throttle. If your chassis is equipped with the remote throttle up option from the chassis manufacturer there is no need to set the throttle up control in the cab because the throttle will automatically increase when any of the carrier hydraulic functions are operated.

! CAUTION

Never exceed 1200 R.P.M. When your hook up is complete, reset the engine idle to normal.

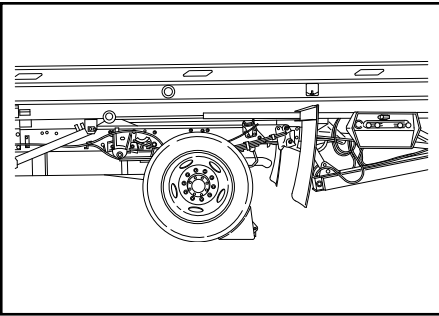

- Block the carrier's rear tires with wheel chocks to prevent accidental carrier movement. Check the area around the carrier and the equipment to be loaded for obstructions or hazards.

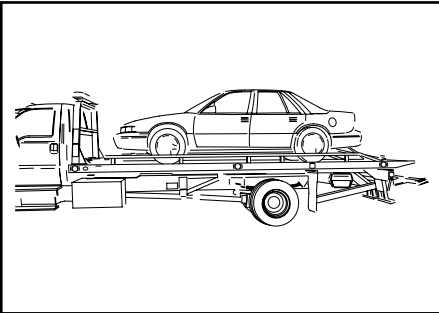

- Slide the deck back. Align the arrow decal pointer on the side of the deck with the deck control switch in the control panel.

NOTICE

Tilting the deck too soon may cause damage to the mechanical hold down.

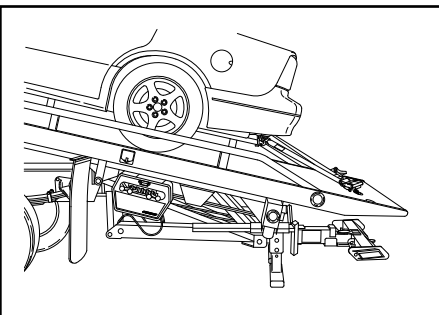

- Raise the front of the deck until the rear bumper rests firmly on the ground.

Section 4 : Operation

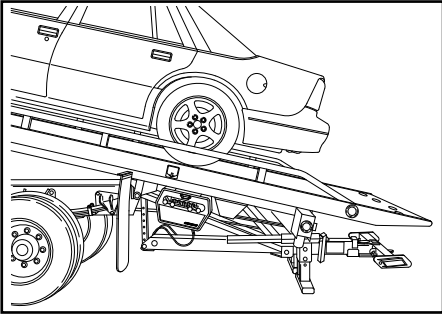

9. Remove the tie-downs from the equipment at the rear of the deck.

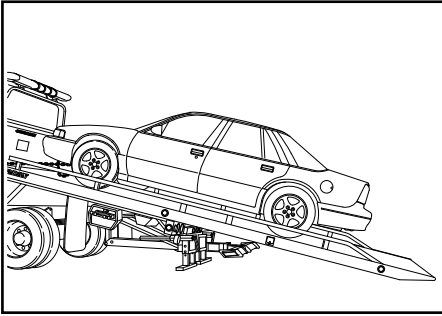

10. Slide the deck back. Slide the deck back until the approach plate makes firm contact with the ground. Make sure that the rear bumper and the approach plate are both in firm contact with the ground before loading so there is equal weight distribution between the rear bumper and the end of the deck.

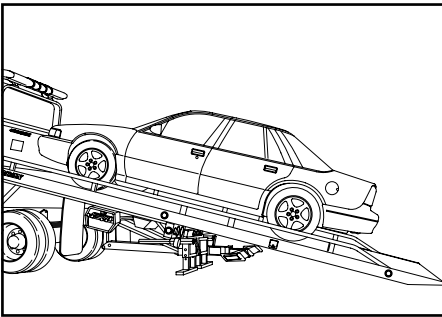

11. Remove the tie-downs from the equipment at the front of the deck.

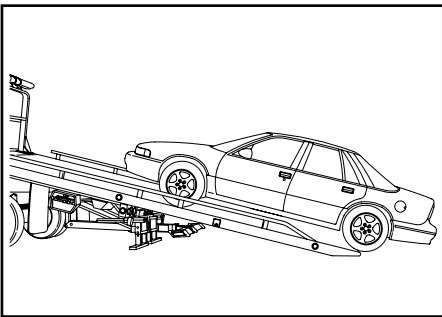

12. Unload vehicle off of the deck.

Section 4: Operation

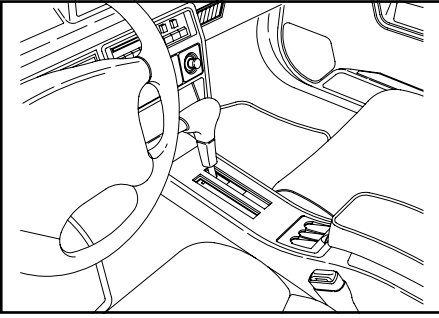

13. Set the equipment's parking brake and put the transmission into Park (if equipped).

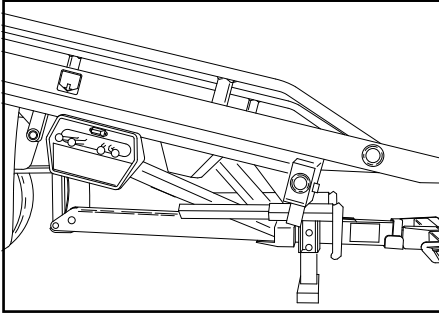

14. Slide the deck forward. Align the arrow decal pointer on the side of the deck with the deck control switch in the control station.

NOTICE

Tilting the deck too soon may cause damage to the mechanical hold down.

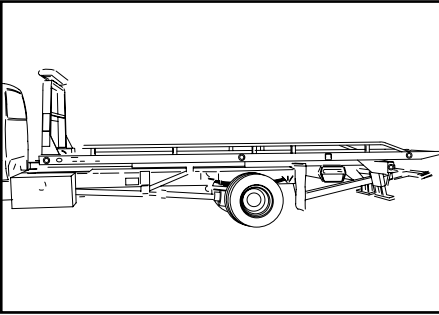

15. Lower the front of the deck to the subframe.

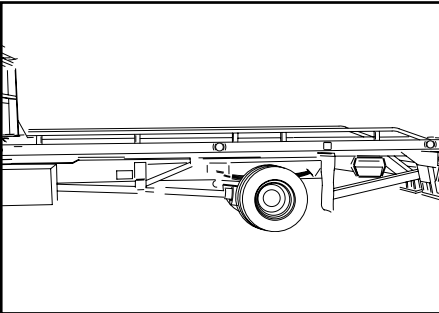

16. Slide the deck completely forward until it engages the hold downs and into the transport position.

Section 4 : Operation

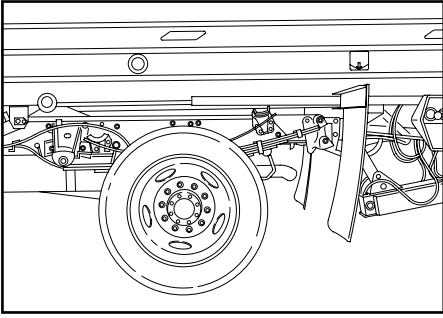

17. Remove the wheel chocks from the carrier's rear tires.

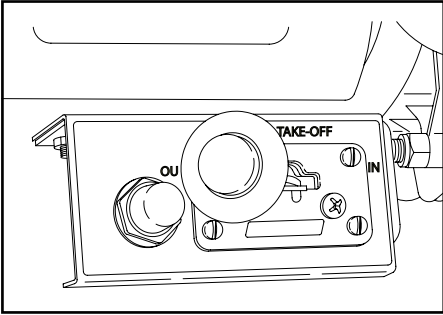

18. Disconnect the power take-off (PTO). Refer to PTO operator's manual.

NOTICE

NEVER TRAVEL WITH THE POWER TAKE OFF CONTROL ENGAGED. This could result in damage to the PTO unit and the recovery vehicle's transmission.

4.3 SECURING VEHICLE

Each Cargo Hauler is supplied with a set of high strength polyester web tie-down strap and chain assemblies. They are to be used to secure the vehicle to the carrier deck. **NEVER TOW A VEHICLE WITHOUT TIE-DOWNS INSTALLED.** For specialty equipment other than vehicles, the user assumes all responsibility for choosing and providing the proper tie-down devices.

The tie-down strap and chain assembly is comprised of the following components:

1. (2) RTJ Hook Cluster Chains
2. (2) RTJ Hook Cluster Straps
3. (2) Ratchet Spool Mechanisms

Follow these steps to properly install the tie-down strap and chain assemblies:

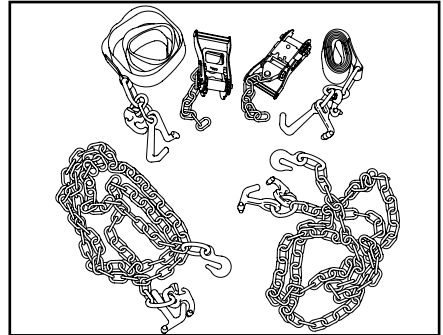

USING THE RATCHET SPOOL MECHANISM

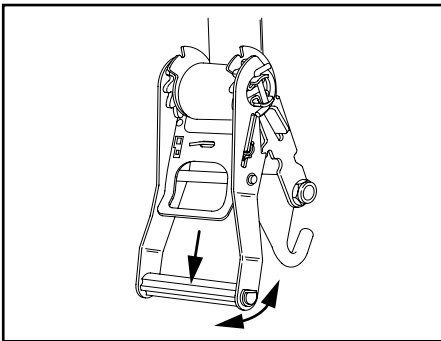

1. First set the spool into “free spool”. This is done by pulling the lock bar out and swinging the handle upward until it rests in the free spool notch and then simply pulling out the amount of strap required to fit over the tire.
2. Now pull on the lock bar and move it downward until it engages the ratchet teeth on the take up spool. By pushing and pulling the handle up and down, the strap will be wound onto the spool.

Section 4 : Operation

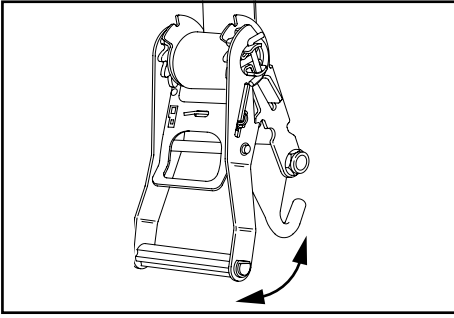

3. To release the ratchet, simply pull on the locking bar, disengaging the teeth and raise the handle to the “free spool” position.

INSTALLING THE FRONT TIE-DOWN CHAINS

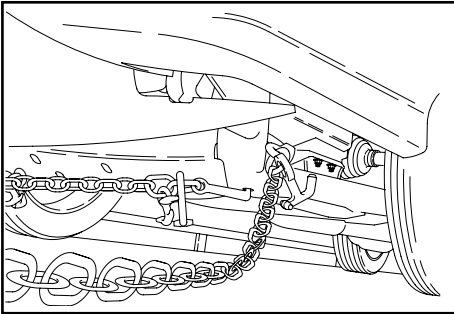

1. Using the RTJ hook cluster chains, insert the appropriate hook into the vehicle frame tie down hole or slot. **Refer to the AAA or vehicle manufacturer's towing manual for the correct attachment points.**

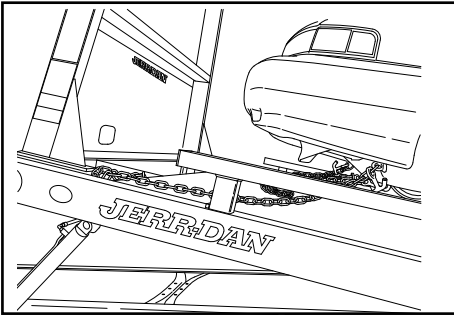

2. Insert the other end of the chain into the key slot in the deck. Adjust the chain so that it is as tight as possible.
3. Repeat for the other side.

INSTALLING THE REAR TIE DOWN STRAPS

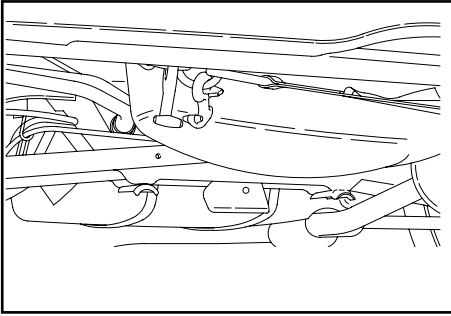

1. Using the RTJ hook cluster straps and ratchet spool mechanisms, insert the appropriate hook into the vehicle frame tie down hole or slot. **Refer to the AAA or vehicle manufacturer's towing manual for the correct attachment points.**

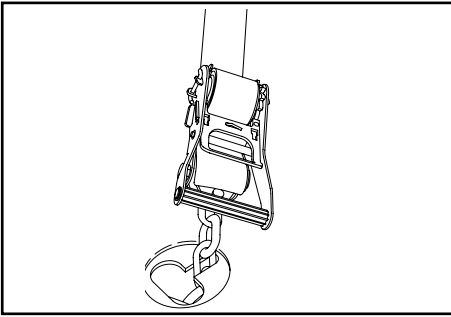

2. Insert the chain on the end of the ratchet into the keyslot in the deck. Adjust the chain so that it is as tight as possible. Using the ratchet, tighten the tie down strap.
3. Repeat for the other side.

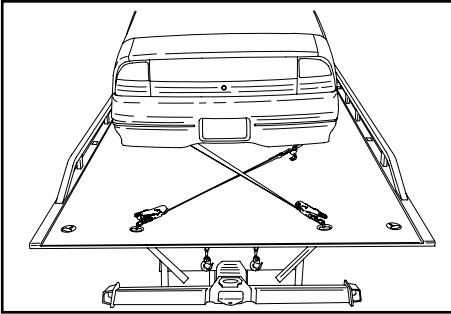

NOTICE

The rear Tie-Downs should be crossed from right to left and left to right whenever possible.

Section 4 : Operation

4.4 “IRL” WHEEL LIFT OPERATION

The optional wheel lift allows a second vehicle to be towed damage free on its own suspension by utilizing a wheel grid. The wheel lift cross bar may also be used as a conventional tow bar for badly damaged or heavier vehicles. **Refer to the AAA or vehicle manufacturer’s towing manual for the correct towing procedures and attachment points.**

WARNING

Because of the additional boom extension and load point of the towed vehicle, the wheel lift places more load on the rear axle and unloads the front axle more than a conventional tow bar. Overloading the wheel lift may result in unsafe steering and braking conditions and may damage truck frame. Never use the wheel lift without a vehicle on the deck. Single vehicle recovery must utilize the deck only.

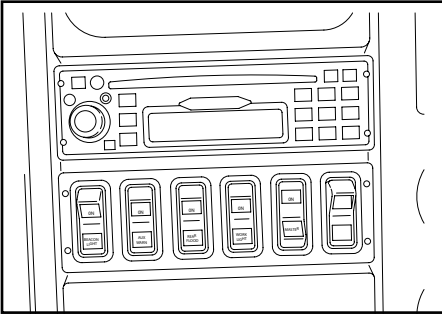

1. Turn on the body lights and any work lights, as necessary. (Switches are located on the switch panel in the dash).

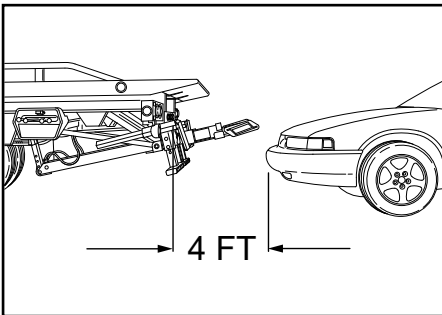

2. Position the rear of the carrier about 4 feet from the vehicle you intend to load. Make sure you are in line with the vehicle to tow.

Section 4: Operation

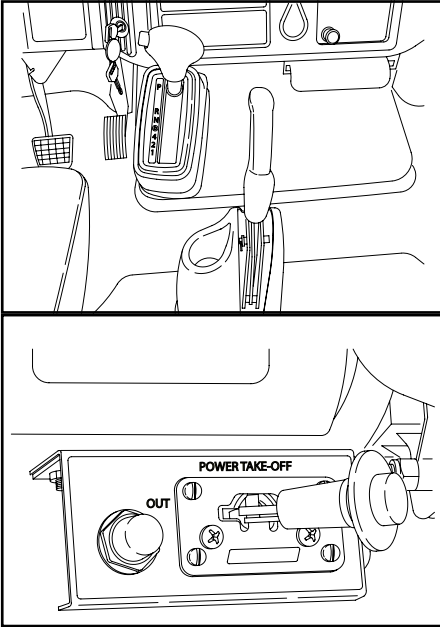

3. Place the carrier's transmission gear selector into Neutral or Park and set the parking brakes.
4. Engage the power take-off (PTO). Refer to PTO operator's manual.

NOTICE

NEVER TRAVEL WITH THE POWER TAKE OFF CONTROL ENGAGED. This could result in damage to the PTO unit and the recovery vehicle's transmission.

5. Adjust the electronic or manual throttle control to set the engine speed to approximately 1000-1200 R.P.M. Refer to chassis operator's manual for proper operation of the auxiliary throttle. If your chassis is equipped with the remote throttle up option from the chassis manufacturer there is no need to set the throttle up control in the cab because the throttle will automatically increase when any of the carrier hydraulic functions are operated.

NOTICE

Never exceed 1200 R.P.M. When your ready to travel, reset the engine idle to normal.

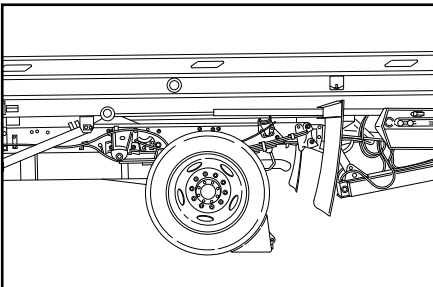

6. Block the carrier's rear tires with wheel chocks to prevent accidental carrier movement. Check the area around the carrier and the equipment to be loaded for obstructions or hazards.

Section 4 : Operation

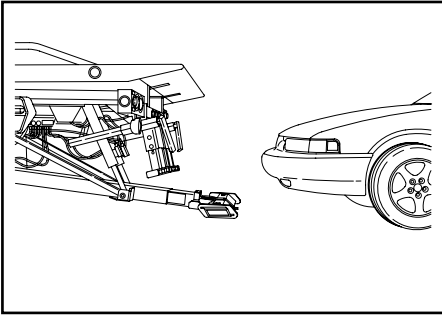

7. Lower the Tow Option Raise/Lower Control handle to lower the wheel lift to about 1-1/2" from the ground. Make sure that it will clear the underside of the vehicle when the wheel lift boom is extended.

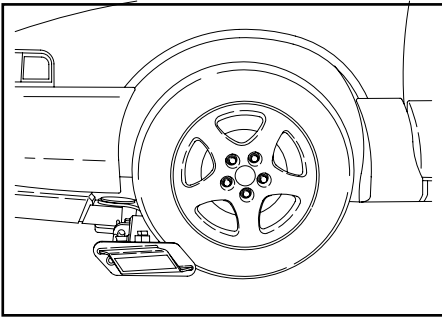

8. Raise the Tow Option Extend/Retract Control handle to extend the wheel lift under the vehicle. Make sure all undercarriage parts are cleared and that the ramp portion of the of grid is in contact with the tires.

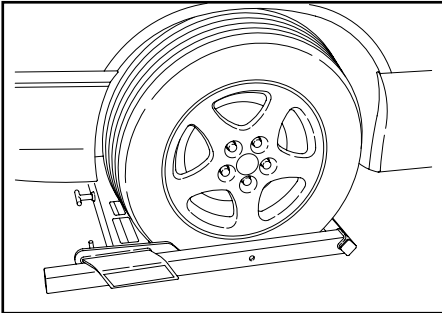

9. Load the vehicle onto the wheel lift. (**See Wheel Grid Operation, Sections 4.5 and 4.6**)

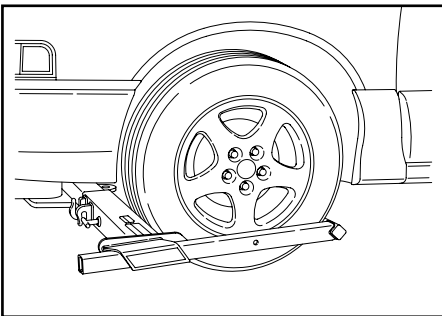

10. Raise the Tow Option Raise/Lower Control handle to raise the wheel lift until the vehicle's tires have cleared the ground.

Section 4: Operation

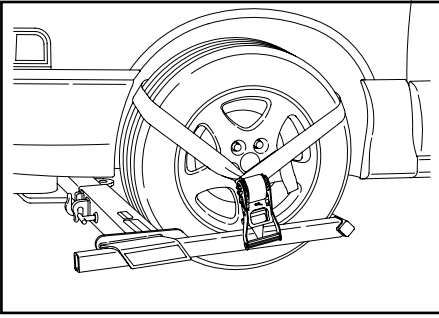

11. Install tie-down straps to secure the wheels in the grid. (**See Tie-Down Straps Installation, Section 4.7**)

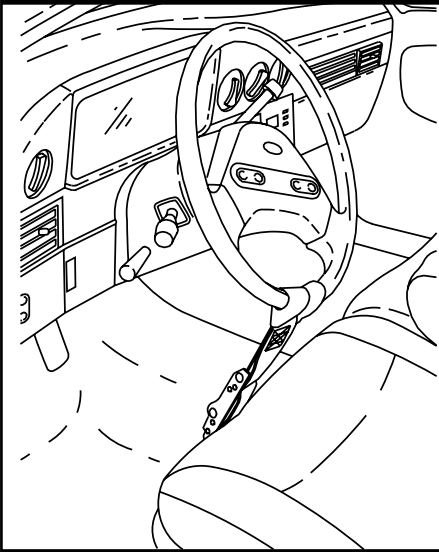

12. Place the vehicle's transmission in Neutral and release the parking brake. Make sure that the wheels are straight and install a steering wheel strap. It is recommended that the steering wheel be secured by a steering wheel strap for any tow.

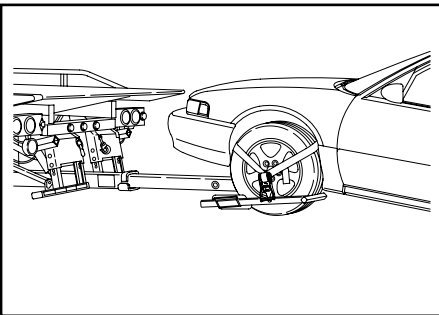

13. Raise the Tow Option Raise/Lower Control handle to raise the wheel lift until the vehicle is in the final towing position.

Section 4 : Operation

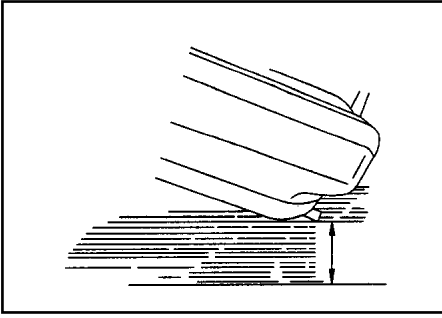

14. Make sure that the far end of the vehicle has enough ground clearance. It is possible to set the rear of a front lifted vehicle completely on the ground. Take irregular road surfaces into consideration. Make sure that there are no under body components of the vehicle in contact with the L-Arms or wheel grid device. Readjust if necessary.

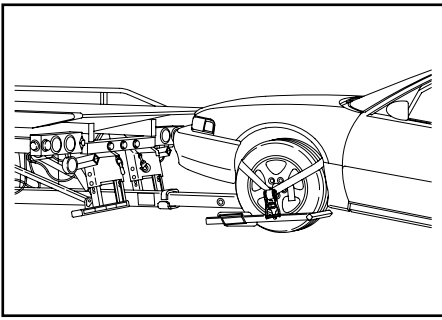

15. Lower the Tow Option Extend/Retract Control handle to retract the wheel lift until the vehicle is about 3 to 4 feet from the back of the truck. Leave enough room to maneuver around corners without corner binding or causing contact between the (2) vehicles. Be sure that the boom is extended adequately to ensure unobstructed crossbar pivoting.

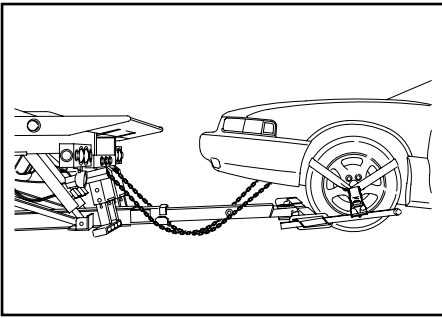

16. Be sure to maintain sufficient clearances with the bottom of the vehicle.

17. Attach the safety chains and magnetic towing lights. The safety chains are located in the chain boxes at the rear of the recovery vehicle. **Safety chains must be crossed from one side of the carrier vehicle to the opposite side of the vehicle.**

Section 4: Operation

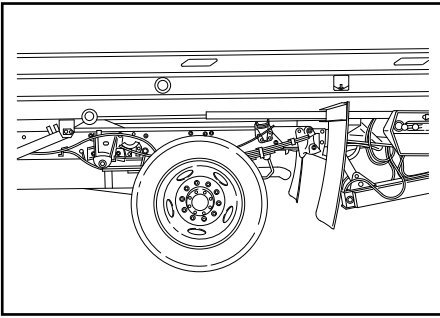

18. Remove the wheel chocks from the carrier's rear tires.

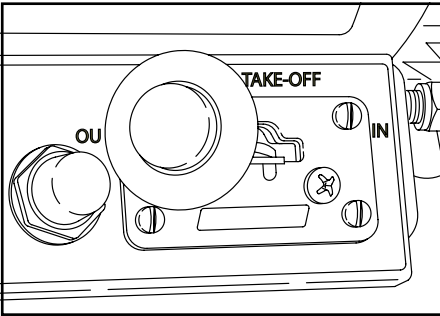

19. Disconnect the power take-off (PTO). Refer to PTO operator's manual.

NOTICE

NEVER TRAVEL WITH THE POWER TAKE OFF CONTROL ENGAGED. This could result in damage to the PTO unit and the recovery vehicle's transmission.

20. Use the reverse order for unloading.

⚠ WARNING

Properly secure the vehicle to the wheel grid using tie-down straps. Tie-down straps should be tightened periodically during the tow as the tires settle into the grid from towing.

⚠ WARNING

Properly secure the vehicle using safety chains from the vehicle to the carrier subframe.

⚠ WARNING

The wheel lift is designed to transport a second vehicle. Never tow a vehicle on the wheel lift without a equipment on the deck. Unsafe braking and steering conditions may result.

Section 4 : Operation

CAUTION

After unloading the vehicle, fully retract the wheel lift boom before operating any deck functions.

CAUTION

Always store the L-Arms in the storage location provided when not in use. Do not store the L-Arms in the wheel grids.

4.5 "L" ARM GRID OPERATION

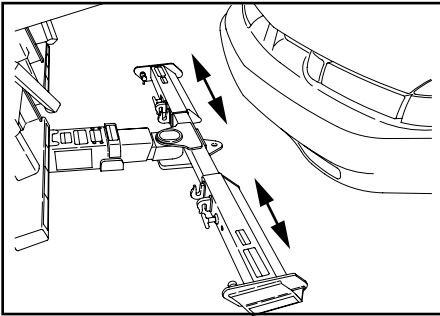

1. Set the grid width as required for the vehicle to be towed.

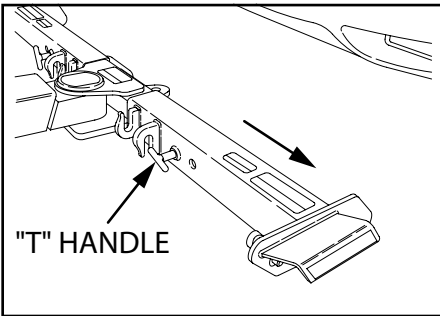

2. To set the grid width, loosen the "T" handles on the front of the grid arms and pull out. Be sure both grids are as close to the center of the boom as possible, and wide enough to allow the L-Arms to slide into their channels. Tighten the "T" handles to secure the grids.

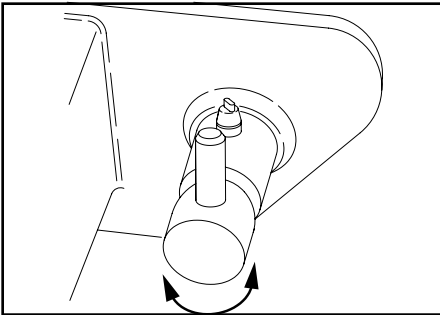

3. Retract the "Cam" handle locking pin on the grid by turning it 180°. It should remain in the open position.

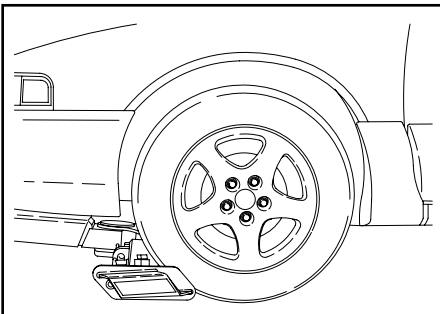

4. Extend the lift arm under the vehicle. Make sure that all under carriage parts are cleared and that the front portion of the grid is in contact with both tires. Lower the grid fully to the ground.

NOTICE

There is no reason for the operator to get under the vehicle.

Section 4 : Operation

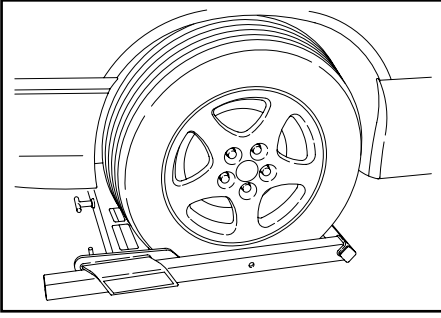

5. Visually inspect the tire to grid contact before proceeding.

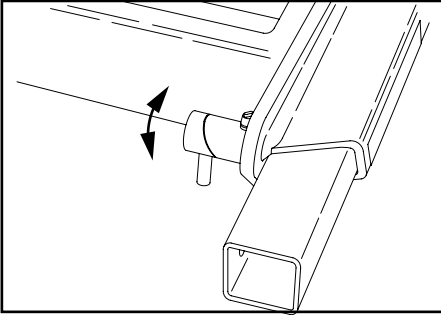

6. Take the L-Arms and slide them into the channels on the side of the grid. Make sure that they are resting snugly against the tires, with the L-Arms in close contact with the tires. Then reset the locking pin by turning the "Cam" handle back to the original position. The tires are now confined front and back.

NOTICE

Be sure that the pin seats in one of the holes.

4.6 "T37" PIVOTING GRID OPERATION

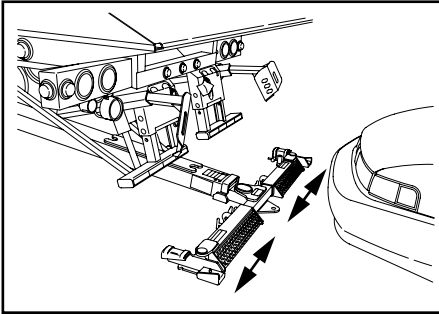

1. Set the grid width as required for the vehicle to be towed.

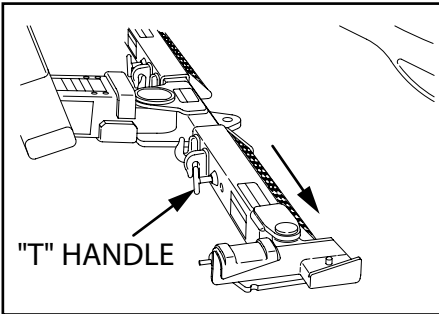

2. To set the grid width, loosen the "T" handles on the front of the grid arms and pull out. Be sure both grids are as close to the center of the boom as possible, and wide enough to allow the wheel restraints to fit into their receivers. Tighten the "T" handles to secure the grids.

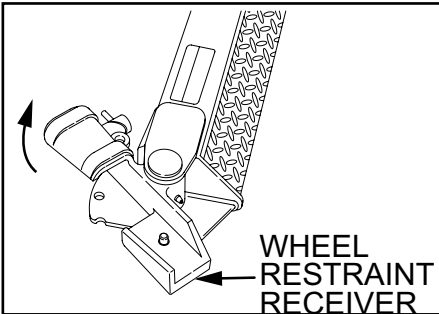

3. Pivot the wheel restraint receivers on the end of the grid arms outward by lifting up on the receiver. Rotate the "Cam" handles on the receivers 180° to the open position for easier placement of the restraint into the receiver.

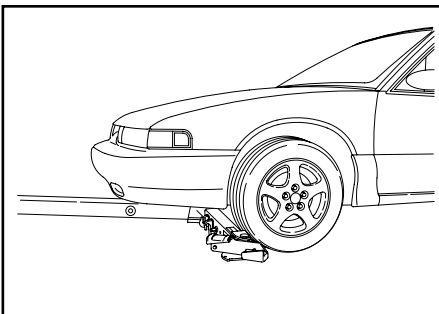

4. Extend the lift arm under the casualty vehicle. Make sure that all under carriage parts are cleared and that the front portion of the grid is in contact with both tires. Lower the grid fully to the ground.

NOTICE

There is no reason for the operator to get under the vehicle.

Section 4 : Operation

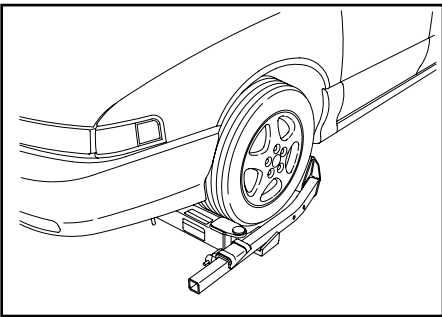
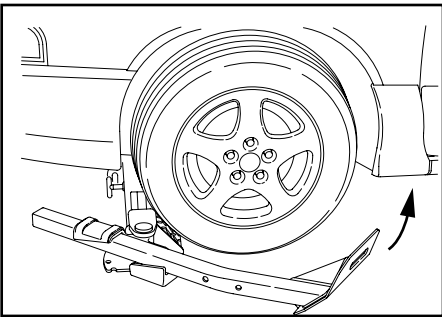
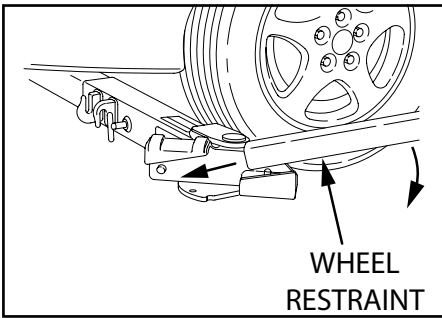

5. Visually inspect the tire to grid contact before proceeding.
6. Take the L-Arms and slide them into the channels on the side of the grid. Make sure that they are resting snugly against the tires, with the L-Arms in close contact with the tires. Then reset the locking pin by turning the "Cam" handle back to the original position. **Be sure that the pin seats in one of the holes.** The tires are now confined front and back.

NOTICE

Be sure that the pin seats in one of the holes.

7. Pivot the receivers and wheel restraints in line with the tires. Make any adjustments to the wheel restraints making sure that you clear body and undercarriage components.

NOTICE

Be sure that the holes in the bottom of the restraints lock over the retaining pin on the receivers.

8. Rotate the "Cam" handles back to their original positions making sure that they fully retract to the closed position. The tires are confined front and back. Readjust the wheel restraints to insure that they are resting snugly against the tires.

4.7 TIE-DOWN STRAPS - L-ARM GRID

The L-Arm grid is supplied with a set of high-strength polyester web tie-down straps. They are to be used to secure wheels of the towed vehicle to the wheel lift grid.

⚠ WARNING

Never tow a vehicle without the tie-down straps installed.

The tie-down strap assembly is comprised of 2 basic components:

1. (2) The Strap/Hook Assemblies
2. (2) The Ratchet Spool Mechanisms

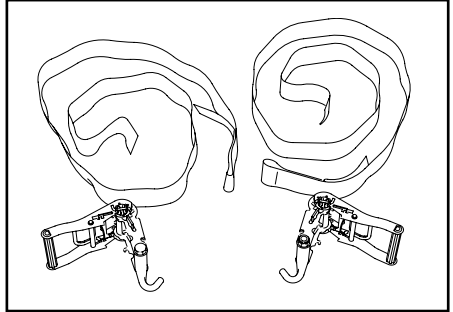

Follow these steps to properly install the tie-down straps:

USING THE RATCHET SPOOL MECHANISM

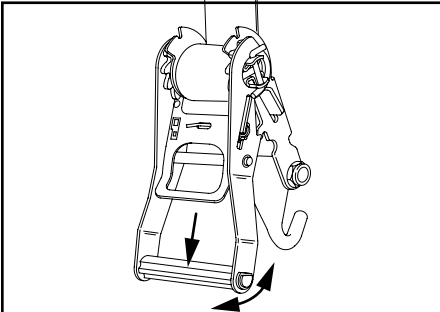

1. First set the spool into “free spool”. This is done by pulling the lock bar out and swinging the handle upward until it rests in the free spool notch and then simply pulling out the amount of strap required to fit over the tire.

2. Now pull on the lock bar and move it downward until it engages the ratchet teeth on the take-up spool. By pushing and pulling the handle up and down, the strap will be wound onto the spool.

3. To release the ratchet, simply pull on the locking bar, disengaging the teeth and raise the handle to the “free spool” position.

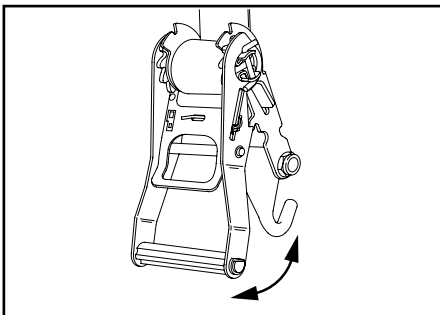

Section 4 : Operation

INSTALLING THE TIE DOWN STRAPS

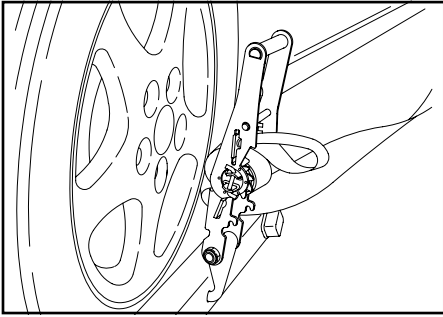

1. With the vehicle lifted just barely off the ground, attach the strap to the L-Arm. Be sure the hook on the ratchet is securely seated in the L-Arm.

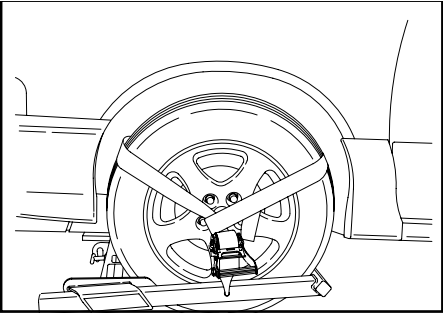

2. Set the ratchet spool in "free spool" position and pull the webbed strap out and form a loop which will wrap around the tire. Be sure the loop is over a minimum of 1/3 of the tire.

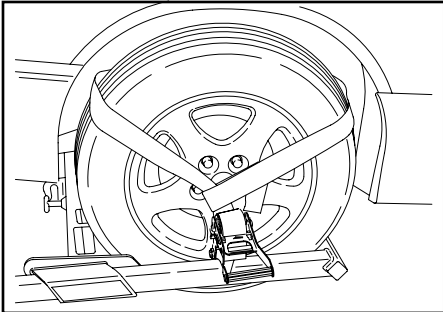

3. Take up the slack in the strap by ratcheting the take-up spool arm. Continue until the tires show some compression. Repeat for other side.
4. Raise the wheel grid to the towing position.

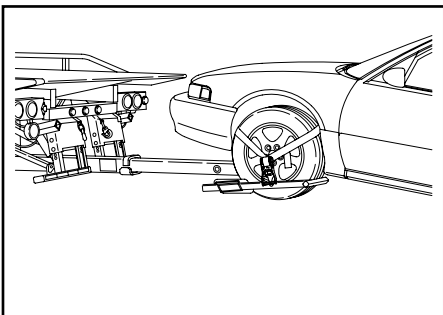

NOTICE

Re-tighten the ratchet periodically as the tire settles in grid from towing.

NOTICE

Never tow a vehicle without tire tie-down straps and safety chains installed.

4.8 TIE-DOWN STRAPS - "T37" GRID

The "T37" pivoting grid is supplied with a set of high-strength polyester web tie-down straps. They are to be used to secure wheels of the towed vehicle to the wheel lift grid.

⚠ WARNING

Never tow a vehicle without the tie-down straps installed.

The tie-down strap assembly is comprised of 2 basic components:

1. (2) The Strap/Hook Assemblies
2. (2) The Ratchet Spool Mechanisms

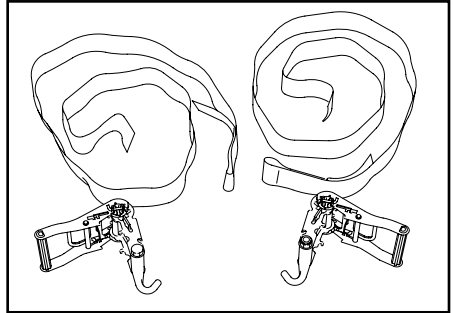

Follow these steps to properly install the tie-down straps:

INSTALLING THE RATCHET SPOOL MECHANISM

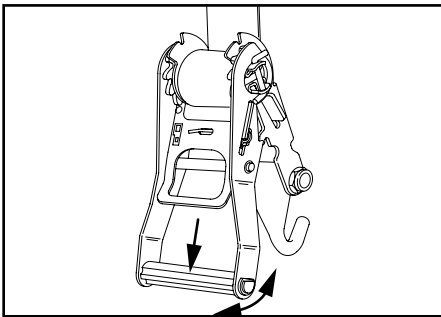

1. First set the spool into "free spool". This is done by pulling the lock bar out and swinging the handle upward until it rests in the free spool notch and then simply pulling out the amount of strap required to fit over the tire.

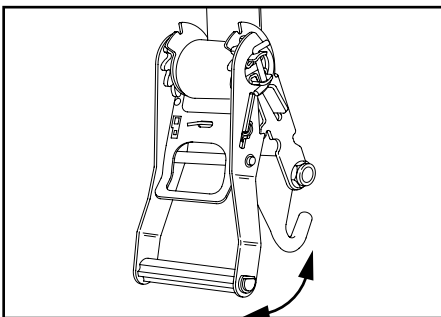

2. Now pull on the lock bar and move it downward until it engages the ratchet teeth on the take-up spool. By pushing and pulling the handle up and down, the strap will be wound onto the spool.
3. To release the ratchet, simply pull on the locking bar, disengaging the teeth and raise the handle to the "free spool" position.

INSTALLING THE TIE DOWN STRAPS

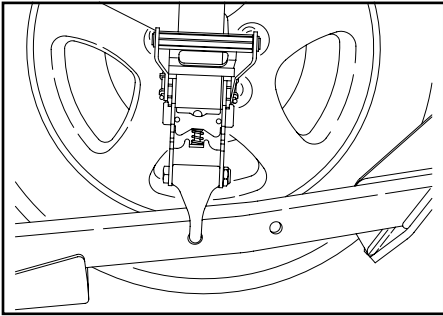

1. With the vehicle lifted just barely off the ground, attach the strap to the wheel restraints. Be sure the hook on the ratchet is securely seated in the wheel restraint.

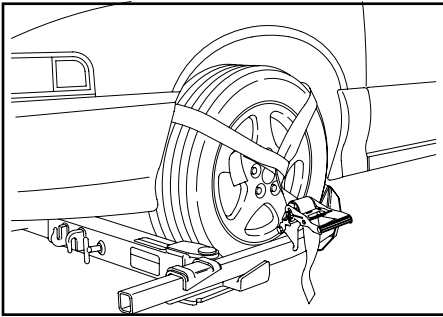

2. Set the ratchet spool in "free spool" position and pull the webbed strap out and form a loop which will wrap around the tire. Be sure the loop is over a minimum of 1/3 of the tire.

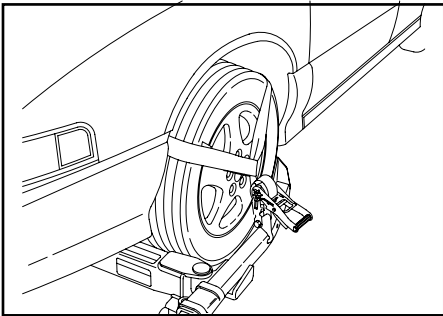

3. Take up the slack in the strap by ratcheting the take-up spool arm. Continue until the tires show some compression. Repeat for other side.
4. Raise the wheel grid to the towing position.

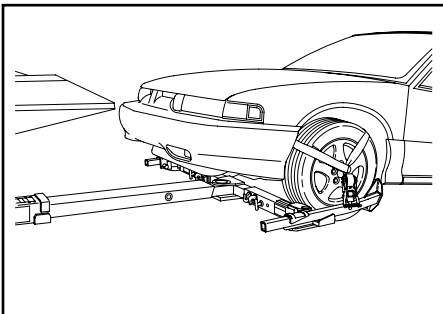

NOTICE

Re-tighten the ratchet periodically as the tire settles in grid from towing.

NOTICE

Never tow a vehicle without tire tie-down straps and safety chains installed..

SECTION 5 - EMERGENCY PROCEDURES

5.1 ELECTRIC/HYDRAULIC FAILURE

RAISING/LOWERING/EXTENDING/RETRACTING DECK

In the event of loss of electric power with an elevated or extended deck, the hydraulics can be operated manually. **Contact a local Authorized Distributor for specific instructions.**

Secure the vehicle using the following procedures:

1. Clear the area around the unit of all personnel.
2. Engage the parking brake. Place the transmission control lever in "PARK".
3. Chock the vehicle's front and rear wheels.
4. If equipment is unsecured on the deck, secure equipment.
5. Section off the area to restrict any personnel from entering the area

Section 5 : Emergency Procedures

5.2 ENGINE FAILURE RAISING/LOWERING/EXTENDING/RETRACTING DECK

In the event of total loss of engine power or hydraulic pump failure with an elevated or extended deck, **Contact a local Authorized Distributor for specific instructions.**

Secure the vehicle using the following procedures:

1. Clear the area around the unit of all personnel.
2. Engage the parking brake. Place the transmission control lever in "PARK".
3. Chock the vehicle's front and rear wheels.
4. If equipment is unsecured on the deck, secure equipment.
5. Section off the area to restrict any personnel from entering the area.

SECTION 6 - MAINTENANCE

6.1 INTRODUCTION

Service the product in accordance with the maintenance schedule on the following pages.

Wear all the protective clothing and personal safety devices issued to you or called for by job conditions.

DO NOT wear loose clothing or jewelry that can get caught on controls or moving parts.

Clean lubrication fittings before lubricating.

Intervals shown are for normal usage and conditions. Adjust intervals for abnormal usage and conditions.

Check all lubricant levels when lubricant is cool. For ease of filling hydraulic reservoir, use a funnel with a hose or flexible tube for best results.

When performing maintenance that requires accessing the top of the truck, use only an approved ladder.



Use only safe practices when maintaining this equipment. Always shut off the engine before reaching into pinch areas.

Place Do Not Operate Tags on the ignition switch and the steering wheel before attempting to perform any service or maintenance. Remove the key and disconnect battery leads.

⚠ WARNING

CUT/CRUSH/BURN HAZARD. Do not perform service or maintenance on the machine with the engine running, with the exception of the hydraulic return filter indicator checks.

⚠ WARNING

The vehicle hydraulic system operates at extremely high and potentially dangerous pressures. The operator must relieve any system pressure before disconnecting or removing any portion of the system.

Section 6 - Maintenance

6.2 MAINTENANCE AND LUBRICATION

The truck chassis itself is on a maintenance schedule recommended by the manufacturer. Follow these guidelines and protect your vehicle warranty.



The carrier deck hold downs and cylinder saddles are mounted to the truck chassis by bolts. We recommend that these bolts be inspected within the first 30 days and inspected and retorqued every 90 days thereafter. Replace any broken or damaged bolts immediately. Refer to chart on the following page.

There are a number of different lubricants used on your vehicle. The following Lubricant Chart shows the proper lubricant and the most common brands and specification which meet the requirements. Refer to Section 6.4.

The hydraulic filter located on the return side of the hydraulic tank comes equipped with restriction indicator gauges. The gauge shows the condition of the filter element. When the needle reaches the red band (25 psi), the filter is starting to bypass and the element needs to be changed. Failure to change the filter element will result in premature wear and/or failure of any or all of the hydraulic components. Only check gauge when hydraulic fluid is at operating temperature. Cold oil is more dense and will give a false indicator gauge reading. Refer to Section 6.4.

For all sling, strap, chain and lifting components refer to the manufacturer inspection and maintenance schedules.

6.3 FASTENER TORQUE SPECIFICATIONS

TIGHTENING TORQUES (FOOT-POUNDS) FOR SCREWS AND NUTS			
SIZE INCHES (MM)	 GRADE 2	 GRADE 5	 GRADE 8
1/4 (6.350)	6	8	10
5/16 (7.938)	10	14	19
3/8 (9.525)	17	27	33
7/16 (11.112)	28	45	60
1/2 (12.700)	45	68	90
9/16 (14.288)	63	100	120
5/8 (15.875)	90	135	180
3/4 (19.050)	145	230	310
7/8 (22.225)	145	380	500
1 (25.400)	220	570	760

- All torque values shown are for bolts (cap screws) and nuts that are either zinc-plated or lubricated.
- Torques shown above apply only to screws and nuts used for assembly and installation of all carrier components, not to the chassis.
- Different torque values may be given in instructions for certain components due to short thread engagement or low-strength internal threads.
- When nuts are used, tighten nuts to torques shown (screws or bolts should be held but not turned). **Always use a calibrated torque wrench.**
- Retighten nuts of all mounting screws that secure the carrier and carrier-body within 30 days after putting the vehicle into service. Thereafter, inspect and retorque such screws and nuts every 90 days and after each job that imposes extremely heavy loads on the equipment.
- Convert ft/lbs to Nm (Newton metres) by using the following formula:

$$\begin{array}{l}
 \text{Multiply:} \\
 \text{ft/lbs}
 \end{array}
 \times
 \begin{array}{l}
 \text{by:} \\
 1.3558
 \end{array}
 =
 \begin{array}{l}
 \text{to get:} \\
 \text{Nm (Newton metres)}
 \end{array}$$

Section 6 - Maintenance

6.4 OILS AND GREASES

The following oils and greases are suitable for use with the Jerr-Dan Vehicle.

Company	Product
HYDRAULIC OILS	
1. Chevron	Clarity AW 46
2. Exxon	Univis N46
3. Mobil	Mobilfluid 424
4. Texaco	Rando HD 46
5. Kendall	AW 46
6. Citgo	Mystik AW 46
7. Amoco	AW 46
8. Conoco	Super
9. Mobil	DTE10 Excel 32 (for cold weather use below 20°F)
10. Conoco	AW Hydraulic Fluid MV 32 (for cold weather use below 20°F)
GREASES	
1. Drydene	HD Lithium EP2
2. Gulf	Crown EP2
3. Amoco	Amolith EP2
4. Shell	Alvania EP2
5. Texaco	Marfax EP2
6. Mobil	Mobilux EP2
7. Sunoco	Prestige EP2

6.4 LUBRICATION CHART

The following lubrication chart located on the headboard on the driver's side of the carrier deck.

INTERVAL (HOURS)	REF NO.	IDENTIFICATION	SERVICE	LUBRICANT	NO. OF POINTS
50 OR MONTHLY	2	T - HANDLE	OIL	ENGINE OIL	2
100 OR BI-MONTHLY	4 3	HYD RESERVOIR CAM LOCK	CHECK LUBE	* MPG	1 2
250 OR SEMI-ANNUALLY	1 5	HOLD DOWN GUIDE HYD FILTER	OIL CHANGE	HYD FLUID ----	2 1
1000 OPERATING HOURS	4	HYD RESERVOIR	DRAIN/FILL	*	1

LUBRICATION CHART
JERRARDIAN
BIC ROLLBACK CARRIERS

CHART COVERS ONLY **JERRARDIAN** BODY COMPONENTS
* INDICATES DUAL RANGE HYD. FLUID 5 W 20
AUTO TRANS FLUID MAY BE SUBSTITUTED IF NECESSARY

DO NOT GREASE SLIDE PADS

478

1007264085 A

Section 6 - Maintenance

LUBRICATION POINTS

Note: The following numbers correspond to those shown on the lubrication chart on Page 6-5.

6. Hydraulic Reservoir Oil Level

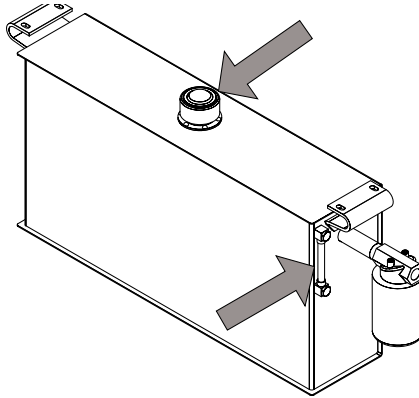

- Lube Point(s) – Site Glass/Fill Cap
- Interval – Check level every 100 hours or bi-monthly
Change every 1000 hours

7. Hydraulic Reservoir Return Filter

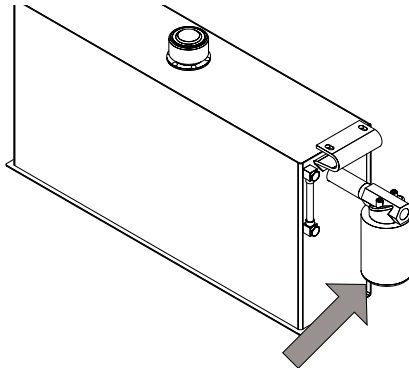

- Lube Point(s) – Replaceable Element
- Interval – Check level every 250 hours or semi-annually

Section 6 - Maintenance

Spool operated hydraulic control valves may build up debris, dirt and/or corrosion under the spring cap. Slower operation of that hydraulic function, even when the control handle is fully actuated, may occur.

It is recommended to annually remove the spring caps on the valve section (usually the opposite side from the spool end clevis) and clean the cap and the items under the cap, to remove any build up.



Apply an approved lubricant to protect those components and reduce the likelihood of further build up. Apply the lubricant generously to spring cap end hardware parts (spring seat, spool end, spring and the inside of the cap itself) to insure complete exposure of all part surfaces to the lubricant. This will ensure optimum operation of your valve sections over the life your equipment.

APPROVED LUBRICANTS:

Mobiltemp SCH Grease (red)

Mobilith SCH PM (white)

Section 6 - Maintenance

6.5 TROUBLE SHOOTING

You probably won't require anything but preventive maintenance to keep your Jerr-Dan running, however, the following chart should help you isolate and correct minor problems if they occur with use. Any service work on the hydraulic system should be performed by qualified mechanics.

HYDRAULIC SYSTEM

Problem	Cause	Solution
Slow operation	a. Low engine RPM b. Low oil level c. Blocked or restricted hose d. Dirty hydraulic oil e. Hydraulic pump worn f. Frozen hydraulic lines	a. Speed up engine b. Check level and fill with the specified oil c. Inspect: remove blockage d. Drain, flush and refill with clean oil, replace filter e. Rebuild or replace f. Thaw and remove water
Valve leaks	a. Defective seals	a. Inspect and replace
Cylinder leaks	a. Defective seals or rods	a. Inspect and replace
Erratic cylinder function	a. Air in the system b. Defective pump (pulsating)	a. Cycle hydraulic system 10 to 15 times to remove air b. Replace if necessary
Remote hand controller fails to respond	a. Electric power turned off	a. Turn on CONTROL power switch in cab
Electric Control Switches fail to respond	a. Electric power turned off b. Electric circuit wiring	a. Turn on CONTROL power switch in cab a. Check/repair electrical wiring circuit problem.

P.T.O. FUNCTIONING IMPROPERLY

Problem	Cause	Solution
Intermittent operation	a. Poor Electrical connection	a. Check electrical connections
Rattling noise in P.T.O.	a. P.T.O. backlash too loose (Consult P.T.O. Manual)	a. Shims must be removed
Howling noise in P.T.O.	a. P.T.O. backlash too tight (Consult P.T.O. Manual)	a. Shims must be added
Gear oil leak between P.T.O. and pump	a. Defective shaft seal	a. Remove and replace
P.T.O. will not engage or disengage	a. Electrical circuit wiring	a. Check/repair electrical wiring problem circuit.
	b. Solenoid Valve malfunctioning	b. Repair or replace
	c. Blown fuse	c. Replace fuse

HYDRAULIC PUMP

Problem	Cause	Solution
Pump noisy (Cavitation)	a. Low oil supply	a. Fill to proper level
	b. Thick oil	b. Fill with proper oil (See chart)
	c. Dirty oil filter	c. Replace filter
	d. Restriction in suction line	d. Clean out and remove
	e. Pump worn	e. Repair or replace
Pump slow or fails to respond	a. Low oil supply	a. Fill to proper level
	b. Cold Thick Oil	b. Drain and refill with a low temperature oil
Oil heating up	a. Foreign material lodged in relief valve filter	a. Inspect and remove/replace
	b. Using too light oil	b. Drain and refill with clean oil
	c. Dirty oil	c. Drain, flush and refill with clean oil/replace filter
	d. Oil level too low	d. Fill to proper level
	e. Pump worn (slippage)	e. Repair or replace

Section 6 - Maintenance

HYDRAULIC PUMP

Problem	Cause	Solution
Oil foaming	a. Air leaking into suction line b. Wrong kind of oil c. Oil level too low	a. Tighten all connections b. Drain and refill with non-foaming type of hydraulic oil (See lube chart) Replace filter c. Refill to proper level
Hydraulic oil leak between P.T.O. and pump	a. Defective shaft seal	a. Replace shaft seal
Pump leaks at front and rear covers	a. Defective seals	a. Replace seals

SECTION 7 - SPECIFICATIONS

7.1 PRODUCT SPECIFICATIONS

6TON STANDARD DUTY CARGO HAULER

Including Models

21NGAR-CH

OPERATING SPECIFICATIONS AND PERFORMANCE DATA

DO NOT EXCEED THE FOLLOWING RATINGS:

DECK RATING:..... 12,000 lb

TOW OPTION RATINGS:	Lift	Tow
IRL Wheel Lift with L-Arm Grids	3,000 lbs	7,500 lbs ¹
IRL Wheel Lift with T-37 Grids.....	3,000 lbs	7,500 lbs ¹
IRL Wheel Lift with Hydraulic Grids	3,000 lbs	7,500 lbs ¹
2-1/2" Reese Receiver		
on Rear Stabailizer.....	1,200 lbs	12,000 lbs
Hydraulic Towbar with Pintle Hook Mounting		
on Rear Stabailizer.....	3,500 lbs	12,000 lbs
2" Reese Hitch Receiver	500 lbs	5,000 lbs
2-1/2" Reese Hitch Receiver	1,200 lbs	12,000 lbs
Stationary Pintle Hitch	4,000 lbs	15,000 lbs

¹ SAE J2512: Surface Vehicle Recommended Practices - Towing Equipment Ratings and Practices

MAXIMUM LIFTING CAPACITY - THE MAXIMUM LOAD THAT CAN BE LIFTED.

GROSS COMBINED WEIGHT RATING (GCWR) - THE VALUE SPECIFIED BY THE VEHICLE MANUFACTURER AS GCW.

GROSS COMBINED WEIGHT (GCW) - ACTUAL WEIGHT OF THE ENTIRE VEHICLE AT THE GROUND WITH TRAILER OR TRAILERS, INCLUDING VEHICLE EQUIPMENT, DRIVER, PASSENGER, FUEL AND PAYLOAD (EVERYTHING THAT MOVES WITH THE VEHICLE).

Section VII : Specifications

NOTE

These ratings apply to the structural design of the carrier only. They might be limited by the axle rating and gross vehicle weight rating of the truck chassis.

The payload and towing capacity of any towing vehicle must meet the following:

- The actual payload on the towing vehicle must not exceed the posted rating and the towed vehicle load must not exceed the posted lift / towing ratings.
- The total weight of the towing vehicle (cab chassis, body, payload, driver, passenger(s), tools, fuel, etc.) and the towed vehicle load must not exceed the GVWR (Gross Vehicle Weight Rating) of the towing vehicle.
- The total weight of the towing vehicle and a towed vehicle load must be distributed so that each axle's GAWR (Gross Axle Weight Rating) is not exceeded.
- The total weight of the towing vehicle and towed vehicle (everything that moves with the towing vehicle) must not exceed the GCWR (Gross Combination Weight Rating) of the towing vehicle.

Staying within these ratings is necessary to maintain the safety and performance of the towing vehicle.

CHECK TRUCK MANUAL FOR SPECIFIC GVW & AXLE RATINGS. ALSO LOOK AT THE CERTIFICATION DECAL AFFIXED TO DRIVER'S SIDE DOOR JAMB, HINGE PILLAR OR LATCH POST AND THE STRUCTURAL CAPACITIES PLACARD ON THE DRIVER'S SIDE OF THE HEADBOARD.

6TON STANDARD DUTY XLP CARGO HAULER

Including Models

- 21NGAR6T-LP-CH
- 21NGADF6T-LP-CH
- 22NGAR6T-LP-CH
- 22NGADF6T-LP-CH

OPERATING SPECIFICATIONS AND PERFORMANCE DATA

DO NOT EXCEED THE FOLLOWING RATINGS:

DECK RATING:..... 12,000 lb

TOW OPTION RATINGS:	Lift	Tow
IRL Wheel Lift with L-Arm Grids	3,500 lbs	10,000 lbs ¹
IRL Wheel Lift with T-37 Grids.....	3,500 lbs	8,000 lbs ¹
IRL Wheel Lift with Hydraulic Grids	3,500 lbs	7,500 lbs ¹
2-1/2" Reese Receiver		
on Rear Stabailizer.....	1,200 lbs	12,000 lbs
Hydraulic Towbar with Pintle Hook Mounting		
on Rear Stabailizer.....	3,500 lbs	12,000 lbs
2" Reese Hitch Receiver	500 lbs	5,000 lbs
2-1/2" Reese Hitch Receiver	1,200 lbs	12,000 lbs
Stationary Pintle Hitch	4,000 lbs	15,000 lbs

¹ SAE J2512: Surface Vehicle Recommended Practices - Towing Equipment Ratings and Practices

MAXIMUM LIFTING CAPACITY - THE MAXIMUM LOAD THAT CAN BE LIFTED.

GROSS COMBINED WEIGHT RATING (GCWR) - THE VALUE SPECIFIED BY THE VEHICLE MANUFACTURER AS GCW.

GROSS COMBINED WEIGHT (GCW) - ACTUAL WEIGHT OF THE ENTIRE VEHICLE AT THE GROUND WITH TRAILER OR TRAILERS, INCLUDING VEHICLE EQUIPMENT, DRIVER, PASSENGER, FUEL AND PAYLOAD (EVERYTHING THAT MOVES WITH THE VEHICLE).

Section VII : Specifications

NOTE

These ratings apply to the structural design of the carrier only. They might be limited by the axle rating and gross vehicle weight rating of the truck chassis.

The payload and towing capacity of any towing vehicle must meet the following:

- The actual payload on the towing vehicle must not exceed the posted rating and the towed vehicle load must not exceed the posted lift / towing ratings.
- The total weight of the towing vehicle (cab chassis, body, payload, driver, passenger(s), tools, fuel, etc.) and the towed vehicle load must not exceed the GVWR (Gross Vehicle Weight Rating) of the towing vehicle.
- The total weight of the towing vehicle and a towed vehicle load must be distributed so that each axle's GAWR (Gross Axle Weight Rating) is not exceeded.
- The total weight of the towing vehicle and towed vehicle (everything that moves with the towing vehicle) must not exceed the GCWR (Gross Combination Weight Rating) of the towing vehicle.

Staying within these ratings is necessary to maintain the safety and performance of the towing vehicle.

CHECK TRUCK MANUAL FOR SPECIFIC GVW & AXLE RATINGS. ALSO LOOK AT THE CERTIFICATION DECAL AFFIXED TO DRIVER'S SIDE DOOR JAMB, HINGE PILLAR OR LATCH POST AND THE STRUCTURAL CAPACITIES PLACARD ON THE DRIVER'S SIDE OF THE HEADBOARD.

TRUCK CHASSIS

OPERATING SPECIFICATIONS AND PERFORMANCE DATA

Refer to Final Stage Vehicle Manufacturer Label affixed to the Driver's Side Door Jam, Hinge Pillar or Latch Post of the cab chassis and the chassis manufacturer's manual.

MFG BY: _____

DATE OF MFR: MO _____ YR. _____

GVWR: _____ KG (_____ LB)

GAWR-FRONT:

_____ KG (_____ LB)

WITH _____ TIRES,

_____ RIMS @ _____ KPA

(_____ PSI) COLD _____

GAWR-INTERMEDIATE(1):

_____ KG (_____ LB)

WITH _____ TIRES,

_____ RIMS @ _____ KPA

(_____ PSI) COLD _____

GAWR-INTERMEDIATE(2):

_____ KG (_____ LB)

WITH _____ TIRES,

_____ RIMS @ _____ KPA

(_____ PSI) COLD _____

GAWR-REAR:

_____ KG (_____ LB)

WITH _____ TIRES,

_____ RIMS @ _____ KPA

(_____ PSI) COLD _____

THIS VEHICLE HAS BEEN COMPLETED IN ACCORDANCE WITH THE PRIOR MANUFACTURERS' IVD, WHERE APPLICABLE. THIS VEHICLE CONFORMS TO ALL APPLICABLE FEDERAL MOTOR VEHICLE SAFETY STANDARDS, [AND BUMPER AND THEFT PREVENTION STANDARDS, IF APPLICABLE] IN EFFECT IN:

MO. _____ YR. _____

VEHICLE IDENTIFICATION NUMBER:

VEHICLE TYPE:

Section VII : Specifications

7.2 CAPACITIES

Hydraulic System

Operating Pressure2500 psi.

System Flow 18 gpm

System Capacity14 gal

Reservoir Capacity12 gal

Type of Oil

0° to 104° F (-20° to 40° C) Mobilfluid® 424

-40° to 0° F (-40° to -20° C)..... Mobile DTE 10 Excel 32M



An Oshkosh Corporation Company

TRANSFER OF OWNERSHIP

To Product Owner:

If you now own but ARE NOT the original purchaser of the product covered by this manual, we would like to know who you are. For the purpose of receiving safety-related bulletins, it is very important to keep Jerr-Dan Corporation updated with the current ownership of all Jerr-Dan products. Jerr-Dan maintains owner information for each Jerr-Dan product and uses this information in cases where owner notification is necessary.

Please use this form to provide Jerr-Dan with updated information with regard to the current ownership of Jerr-Dan products. Please return completed form to the Jerr-Dan Product Safety & Reliability Department via facsimile or mail to address as specified below.

Thank You,
Product Safety & Reliability Department
Jerr-Dan Corporation
13224 Fountainhead Plaza
Hagerstown, MD 21742
USA
Telephone: +1-717-485-6591
Fax: +1-301-745-3713

NOTE: Leased or rented units should not be included on this form.

Mfg. Model : _____

Serial Number : _____

Previous Owner : _____

Address : _____

Country : _____ Telephone : (_____) _____

Date of Transfer : _____

Current Owner : _____

Address : _____

Country : _____ Telephone : (_____) _____

Who in your organization should we notify?

Name : _____

Title : _____

THIS PAGE IS INTENTIONALLY LEFT BLANK

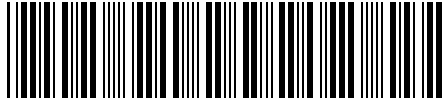

5376000234

JERR-DAN

An Oshkosh Corporation Company

*13224 Fountainhead Plaza
Hagerstown, MD 21742
Phone (717) 597-7111*

TOW 
SUPPORT
by **JERR-DAN**

Phone (800) 926-9666

www.jerr-dan.com