

STANDARD DUTY CARRIER PARTS MANUAL

JERR-DAN[®]

An Oshkosh Truck Corporation Company

1080 Hykes Road
Greencastle, PA 17225
Phone (717) 597-7111
www.jerr-dan.com

5-376-000089
Rev 3 - April 01, 2007

© 2007 Jerr-Dan Corporation. All Rights Reserved.

This manual covers the following Jerr-Dan Models:

NGAF	-	5 Ton Pioneer Fixed Rail	WSRB	-	5 Ton Steel Rustler
NGADF	-	5 Ton Pioneer Aluminum Dual Angle Fixed Rail	RRSB	-	5 Ton Steel B.I.C.
NGAR	-	5 Ton Pioneer Aluminum Removable Rail	SLPB	-	5 Ton Steel Shark
NGAT	-	5 Ton Pioneer Aluminum Transporter	STRB	-	5 Ton Steel B.I.C. Transporter

Jerr-Dan Corporation strives to provide information that is accurate, complete and useful. Descriptions and illustrative material contained within this manual are as accurate as known at the time of publication and are subject to change, without notice, as a result of continuous product improvements. Jerr-Dan reserves the right to amend the information in this document at any time without prior notice.

Information contained in this manual reflects how this vehicle was built at the factory. Modifications or additions by the distributor or owner are not reflected in this manual.

This parts manual does not include service parts information for the commercial chassis (IHC, Ford, GM, etc.). This parts information is provided by the chassis manufacturer.

When ordering parts, please refer to your unit's Sales Order Number, Serial Number and Model Number. This information can be found on the aluminum tag riveted to the front left corner of the deck as shown below:

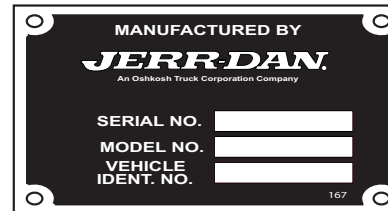

Additional or replacement manuals can be ordered by calling Jerr-Dan Parts at 717-597-7111. Price and availability will be quoted at time of the request.

Please report comments and/or errors by contacting Jerr-Dan Corporation's Technical Publications Department by e-mail at technicalpublications@jerr-dan.com or by FAX on 717-593-2362.

Manufactured under one or more of the following patents: 5,044,865; 5,133,633; 5,575,606; 5,697,741; 5,951,235; 6,231,294 B1; 6,336,783 B1; and 6,447,239 B2 with other Patents Pending.

Jerr-Dan and the Jerr-Dan logo are registered trademarks of Jerr-Dan Corporation, Greencastle, PA USA.

The material in this document is confidential and the property of Jerr-Dan Corporation. No part of this document may be photocopied, reproduced or translated to another language without the express written consent of Jerr-Dan Corporation.

INDEX

DESCRIPTION	PAGE	DESCRIPTION	PAGE
Deck - Pioneer Aluminum Fixed Rail (NGAF)	4 - 5	Hydraulic Components - IRL Tow Option	96 - 97
Deck - Pioneer Aluminum Dual Angle Fixed Rail (NGADF)	6 - 7	Hydraulic Components - Hydraulic Extend Tow Option	98 - 99
Deck - Pioneer Aluminum Removable Rail (NGAR)	8 - 9	Electrical Components - Standard w/ Bolt-On Headboard	100 - 101
Deck - Pioneer Aluminum Transporter (NGAT)	10 - 11	Electrical Components - Standard w/ Stationary Headboard	102 - 103
Deck - Steel Rustler (WSRB)	12 - 13	Electrical Components - Optional	104 - 105
Deck - Steel B.I.C (RRSB)	14 - 15	IRL Wheel Lift	106 - 107
Deck - Steel Shark (SLPB)	16 - 17	ZOD Wheel Lift	108 - 109
Deck - Steel B.I.C. Transporter (STRB)	18 - 19	Manual L-Arm Wheel Lift Grid	110 - 111
Standard Headboard & Remote Winch Free Spool	20 - 21	Manual T37 Pivoting Wheel Lift Grid	112 - 113
Deluxe Headboard & Remote Winch Free Spool	22 - 23	Hydraulic Wheel Lift Grid	114 - 119
Stationary Headboard & Remote Winch Free Spool	24 - 25	Hydraulic Rear Dock Stabilizer	120 - 121
Worm Gear Winch	26 - 27	Stabilizer w/ Reese Hitch Receiver	122 - 123
Planetary Gear Winch	28 - 29	Stabilizer w/ Manual Extend Pintle Hitch Mounting Plate	124 - 125
Worm Gear Winch Cable Roller / Tensioner Plate	30 - 31	Stabilizer w/ Hydraulic Extend Pintle Hitch Mounting Plate	126 - 127
Planetary Gear Winch Cable Roller / Tensioner Plate	32 - 33	Ball Hitch Mounting Plate - IRL	128 - 129
Subframe (Outboard Tilt Cylinders)	34 - 35	Ball Hitch Mounting Plate - Hydraulic Extend	130 - 131
Subframe (Inboard Tilt Cylinders)	36 - 37	Ball Hitch Mounting Plate - Manual Extend	132 - 133
Hold Down (Outboard Tilt Cylinders)	38 - 39	Pintle Hitch Mounting Plate - IRL	134 - 135
Hold Down (Inboard Tilt Cylinders)	40 - 41	Pintle Hitch Mounting Plate - Hydraulic Extend	136 - 137
Slide Pad	42 - 43	Pintle Hitch Mounting Plate - Manual Extend	138 - 139
Mud Flap	44 - 45	Towbar - IRL	140 - 141
Final Assembly	46 - 47	Towbar - Hydraulic Extend	142 - 143
Ford F550 Frame Reinforcement and Spring Spacers	48 - 49	Roll Cylinder Assembly	144 - 145
Ford F550 Subframe Modifications	50 - 51	Tilt Cylinder Assembly (Outboard)	146 - 147
GM C4500/5500 Subframe Modifications	52 - 53	Tilt Cylinder Assembly (Inboard)	148 - 149
GM C4500/5500 Brake Cable Rework and Rear Fuel Tank Modification	54 - 55	Wheel Lift Extend Cylinder Assembly	150 - 151
Hydraulic Reservoir and Toolbox / Basket	56 - 59	IRL Cylinder Assembly	152 - 153
Toolbox	60 - 61	ZOD Cylinder Assembly	154 - 155
Toolbox Shelf	62 - 63	Stabilizer Cylinder Assembly	156 - 157
Toolbox Light	64 - 65	Tow Option Hydraulic Extend Cylinder Assembly	158 - 159
Dual Controls - 3 Bank	66 - 67	Lightbars	160 - 161
Dual Controls - 4 Bank	68 - 69	Switch Panels	162 - 163
Dual Controls - 5 Bank	70 - 71	Work Lights	164 - 165
Dual Controls - 6 Bank	72 - 73	Bolt-On D-Rings	166 - 167
Dual Controls - 7 Bank	74 - 75	Remote Control Operation(s)	168 - 169
Hydraulic Components - Standard	76 - 77	Remote Throttle Control	170 - 171
Hydraulic Components - Standard (Hose Track)	78 - 79	Glad Hands and 7-Way Connector	172 - 173
Hydraulic Components - Hose Routing / Mounting	80 - 81	Air Supply Disconnet	174 - 175
Hydraulic Components - IRL Wheel Lift w/ Manual Grids	82 - 83	Jump Start Kit	176 - 177
Hydraulic Components - IRL Wheel Lift w/ Hydraulic Grids	84 - 85	Folding Deck Ladder	178 - 179
Hydraulic Components - ZOD Wheel Lift w/ Manual Grids	86 - 87	Chains and Straps	180 - 181
Hydraulic Components - ZOD Wheel Lift w/ Hydraulic Grids	88 - 89	Decals	182 - 183
Hydraulic Components - Stabilizer	90 - 91	Hydraulic Schematic	184 - 190
Hydraulic Components - Stabilizer w/ Reese Hitch Receiver or Pintle Hitch Mtg Plate	92 - 93	Electrical Schematic	191
Hydraulic Components - Stabilizer w/ Hydraulic Extend Pintle Hitch Mounting Plate	94 - 95		

DECK - PIONEER ALUMINUM FIXED RAIL (NGAF)

ITEM	PART NO.	DESCRIPTION	QTY
1	3097000477	19' Deck - 96" wide	1
	3097000478	19' Deck - 102" wide	
	3097000475	20' Deck - 96" wide	
	3097000476	20' Deck - 102" wide	
	3097000473	21' Deck - 96" wide	
	3097000474	21' Deck - 102" wide	
2	7493000009	Marker Light Grommet	6
3	7590000249	Marker Light - Amber (Std)	4
	7590000239	Marker Light - Amber (LED)	
4	7590000245	Marker Light - Red (Std)	2
	7590000238	Marker Light - Red (LED)	
5	7493000010	Marker Light Grommet	2
6	7590000250	Marker Light - Amber (Std)	2
	7590000242	Marker Light - Amber (LED)	
7	7330000498	Reflector - Amber	8
8	7330000497	Reflector - Red	4
9	7679000017	Chain Tray Mat	2

DECK - PIONEER ALUMINUM FIXED RAIL (NGAF)

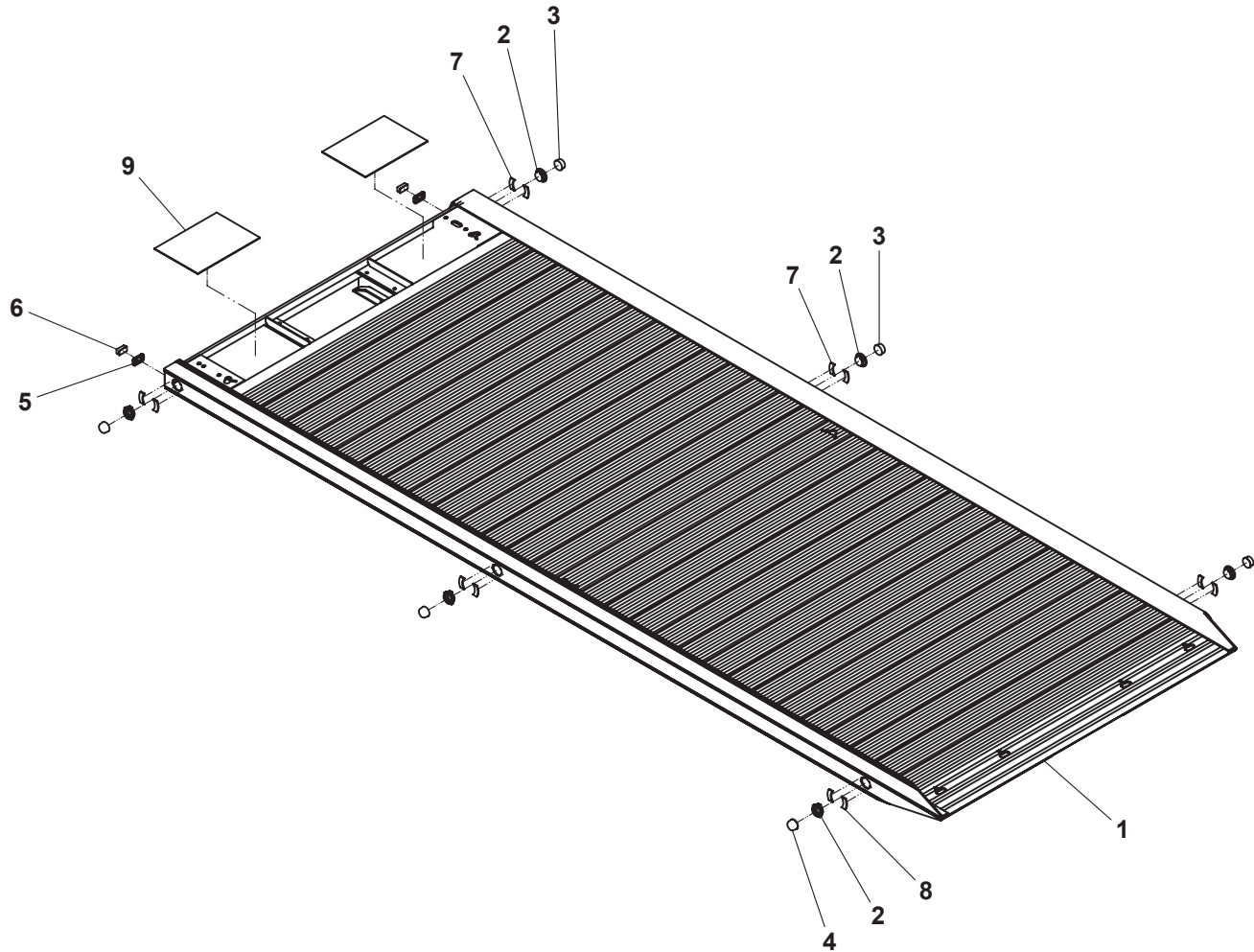

21' deck shown

DECK - ALUMINUM DUAL ANGLE FIXED RAIL (NGADF)

ITEM	PART NO.	DESCRIPTION	QTY
1	3097000417	19' Deck - 96" wide	1
	3097000443	19' Deck - 102" wide	
	3097000413	20' Deck - 96" wide	
	3097000439	20' Deck - 102" wide	
	3097000409	21' Deck * 96" wide	
	3097000435	21' Deck - 102" wide	
2	7493000009	Marker Light Grommet	6
3	7590000249	Marker Light - Amber (Std)	4
	7590000239	Marker Light - Amber (LED)	
4	7590000245	Marker Light - Red (Std)	2
	7590000238	Marker Light - Red (LED)	
5	7493000010	Marker Light Grommet	2
6	7590000250	Marker Light - Amber (Std)	2
	7590000242	Marker Light - Amber (LED)	
7	7330000498	Reflector - Amber	8
8	7330000497	Reflector - Red	4
9	7679000017	Chain Tray Mat	2

DECK - ALUMINUM DUAL ANGLE FIXED RAIL (NGADF)

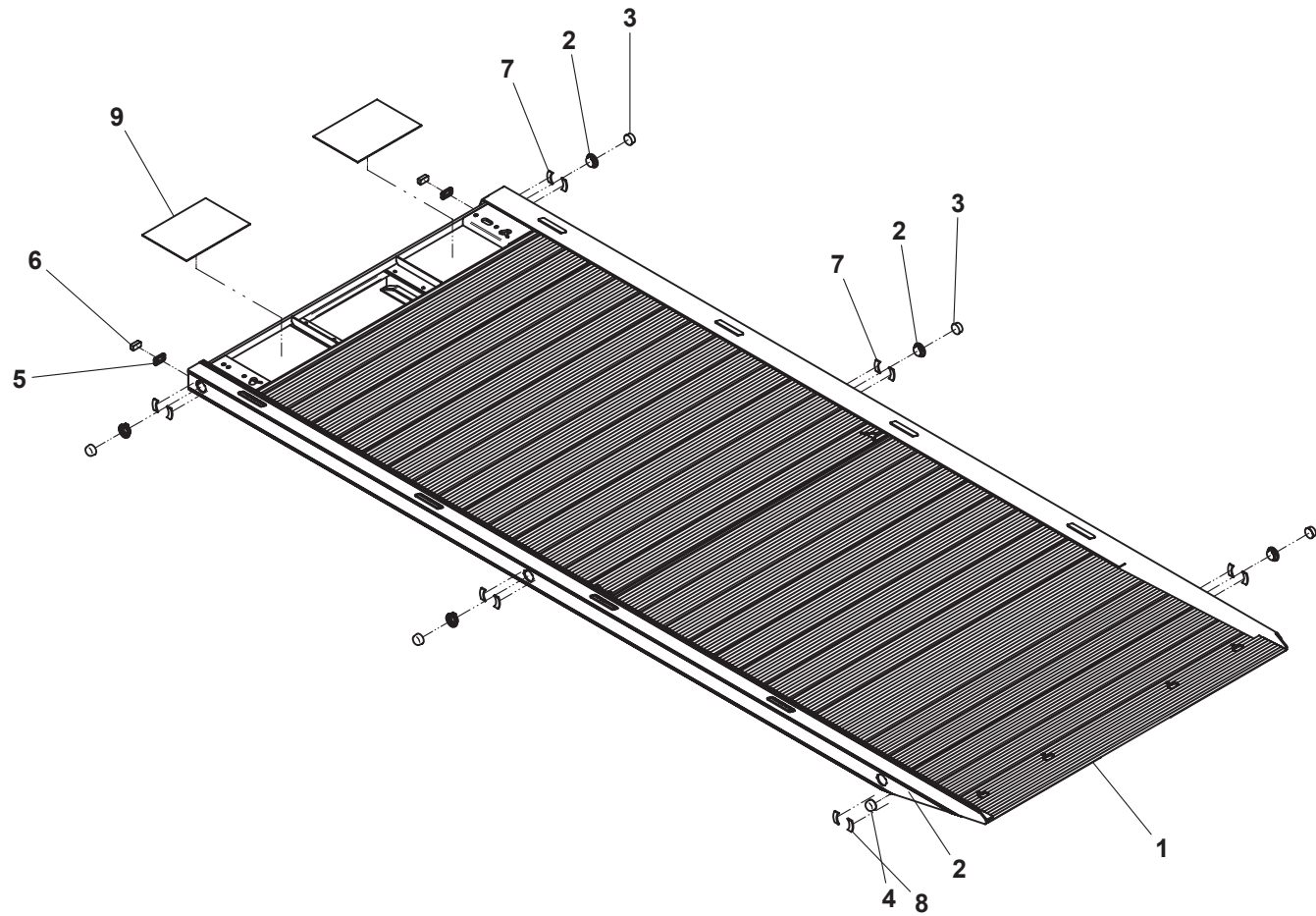

21' deck shown

DECK - ALUMINUM REMOVABLE RAIL (NGAR)

ITEM	PART NO.	DESCRIPTION	QTY	ITEM	PART NO.	DESCRIPTION	QTY
1	3097000419	19' Deck - 96" wide	1			<i>Standard Aluminum Removable Rails:</i>	
	3097000445	19' Deck - 102" wide					
	3097000415	20' Deck - 96" wide		10	3017000084	Aluminum Rail, LH Front	1
	3097000441	20' Deck - 102" wide		11	3017000085	Aluminum Rail, RH Front	1
	3097000411	21' Deck - 96" wide		12	3017000088	Aluminum Rail, LH Rear (19' & 20' decks)	1
	3097000437	21' Deck - 102" wide			3017000086	Aluminum Rail, LH Rear (21' deck)	
2	7493000009	Marker Light Grommet	6	13	3017000089	Aluminum Rail, RH Rear (19' & 20' deck)	1
3	7590000249	Marker Light - Amber (Std)	4		3017000087	Aluminum Rail, RH Rear (21' deck)	
	7590000239	Marker Light - Amber (LED)		14	3706000181	Plate Weld (19' & 20' decks)	10
4	7590000245	Marker Light - Red (Std)	2			Plate Weld (21' deck)	12
	7590000238	Marker Light - Red (LED)		15	7115181650	Capscrew, 0.50"-13NC x 2.00" (19' & 20' decks)	10
5	7493000010	Marker Light Grommet	2			Capscrew, 0.50"-13NC x 2.00" (21' deck)	12
6	7590000250	Marker Light - Amber (Std)	2	16	Not Required		
	7590000242	Marker Light - Amber (LED)				<i>Optional Steel Tubular Removable Rails:</i>	
7	7330000498	Reflector - Amber	8				
8	7330000497	Reflector - Red	4				
9	7679000017	Chain Tray Mat	2				
				10	3729000115	Steel Rail, LH Front (19' & 20' decks)	1
					3729000126	Steel Rail, LH Front (21' deck)	
				11	3729000115	Steel Rail, RH Front (19' & 20' decks)	1
					3729000126	Steel Rail, RH Front (21' deck)	
				12	3729000129	Steel Rail, LH Rear (19' & 20' decks)	1
					3729000127	Steel Rail, LH Rear (21' deck)	
				13	3729000130	Steel Rail, RH Rear (19' & 20' deck)	1
					3729000128	Steel Rail, RH Rear (21' deck)	
				14	3706000181	Plate Weld (19' & 20' decks)	10
						Plate Weld (21' deck)	12
				15	7120000005	Capscrew, 0.50"-13NC x 2.50" (19' & 20' decks)	10
						Capscrew, 0.50"-13NC x 2.50" (21' deck)	12
				16	7701000033	End Cap	4

DECK - ALUMINUM REMOVABLE RAIL (NGAR)

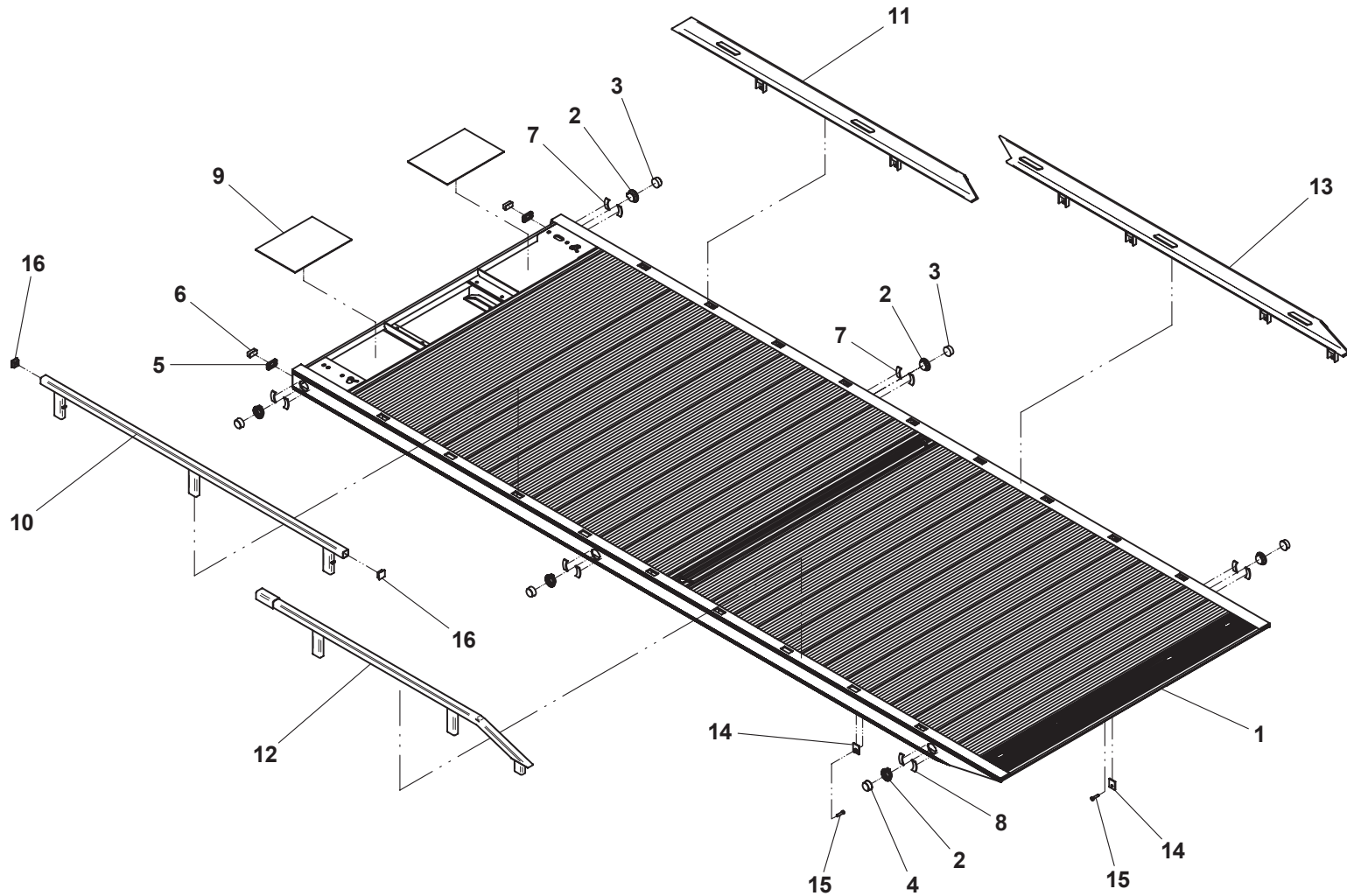

21' deck shown with standard removable aluminum rails on right side and optional steel removable rails on left side

DECK - ALUMINUM TRANSPORTER (NGAT)

ITEM	PART NO.	DESCRIPTION	QTY	ITEM	PART NO.	DESCRIPTION	QTY
1	3097000420	19' Deck - 95" wide, 12" X-mem spacing	1			<i>Standard Aluminum Removable Rails:</i>	
	3097000486	19' Deck - 95" wide, 8" X-mem spacing					
	3097000446	19' Deck - 102" wide, 12" X-mem spacing		12	3017000084	Aluminum Rail, LH Front	1
	3097000487	19' Deck - 102" wide, 8" X-mem spacing		13	3017000085	Aluminum Rail, RH Front	1
	3097000416	20' Deck - 95" wide, 12" X-mem spacing		14	3017000088	Aluminum Rail, LH Rear (19' & 20' decks)	1
	3097000484	20' Deck - 95" wide, 8" X-mem spacing			3017000086	Aluminum Rail, LH Rear (21' deck)	
	3097000442	20' Deck - 102" wide, 12" X-mem spacing		15	3017000089	Aluminum Rail, RH Rear (19' & 20' deck)	1
	3097000485	20' Deck - 102" wide, 8" X-mem spacing			3017000087	Aluminum Rail, RH Rear (21' deck)	
	3097000412	21' Deck - 95" wide, 12" X-mem spacing		16	3706000181	Plate Weld (19' & 20' decks)	10
	3097000482	21' Deck - 95" wide, 8" X-mem spacing				Plate Weld (21' deck)	12
	3097000438	21' Deck - 102" wide, 12" X-mem spacing		17	7115181650	Capscrew, 0.50"-13NC x 2.00"	10
	3097000483	21' Deck - 102" wide, 8" X-mem spacing				(19' & 20' decks)	
2	7493000009	Marker Light Grommet	6			Capscrew, 0.50"-13NC x 2.00" (21' deck)	12
3	7590000249	Marker Light - Amber (Std)	4	18	Not Required		
	7590000239	Marker Light - Amber (LED)					
4	7590000245	Marker Light - Red (Std)	2			<i>Optional Steel Tubular Removable Rails:</i>	
	7590000238	Marker Light - Red (LED)					
5	7493000010	Marker Light Grommet	2				
6	7590000250	Marker Light - Amber (Std)	2	12	3729000115	Steel Rail, LH Front (19' & 20' decks)	1
	7590000242	Marker Light - Amber (LED)			3729000126	Steel Rail, LH Front (21' deck)	
7	7330000498	Reflector - Amber	8	13	3729000115	Steel Rail, RH Front (19' & 20' decks)	1
8	7330000497	Reflector - Red	4		3729000126	Steel Rail, RH Front (21' deck)	
9	7679000017	Chain Tray Mat	2	14	3729000129	Steel Rail, LH Rear (19' & 20' decks)	1
10	Contact Parts	Keruing Board	A/R		3729000127	Steel Rail, LH Rear (21' deck)	
11	7786000007	Screw, 0.31"-18NC x 2.00"	A/R	15	3729000130	Steel Rail, RH Rear (19' & 20' deck)	1
					3729000128	Steel Rail, RH Rear (21' deck)	
				16	3706000181	Plate Weld (19' & 20' decks)	10
						Plate Weld (21' deck)	12
				17	7120000005	Capscrew, 0.50"-13NC x 2.50"	10
						(19' & 20' decks)	
						Capscrew, 0.50"-13NC x 2.50" (21' deck)	12
				18	7701000033	End Cap	4

DECK - ALUMINUM TRANSPORTER (NGAT)

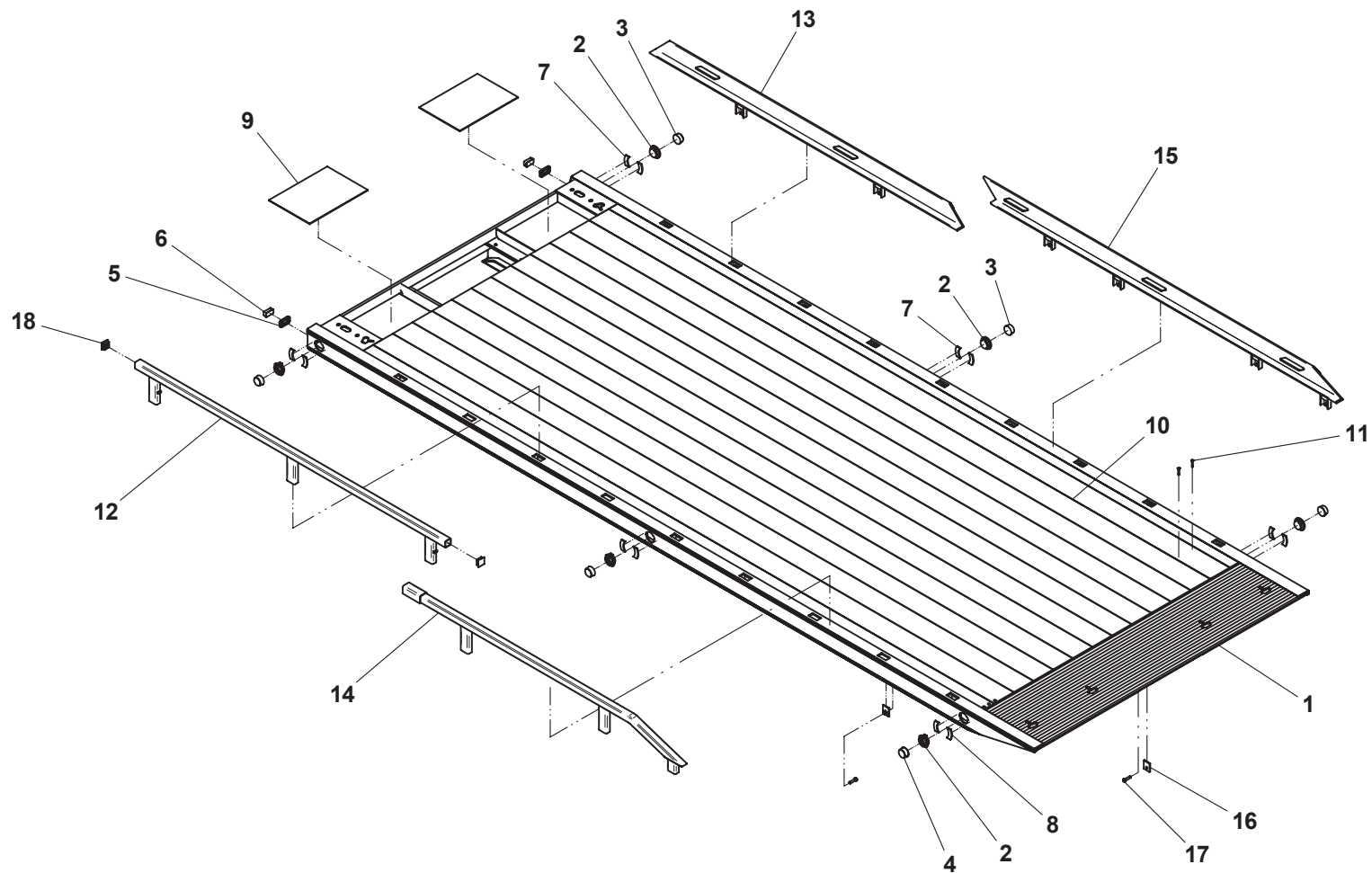

21' deck shown with optional removable steel rails on left side and optional aluminum removable rails on right side

DECK - STEEL RUSTLER (WSRB)

ITEM	PART NO.	DESCRIPTION	QTY
1	3097000265	19' Deck - 96" wide, 12" X-mem spacing	1
	3097000280	19' Deck - 96" wide, 8" X-mem spacing	
	3097000456	19' Deck - 102" wide, 12" X-mem spacing	
	3097000460	19' Deck - 102" wide, 8" X-mem spacing	
	3097000455	20' Deck - 96" wide, 12" X-mem spacing	
	3097000459	20' Deck - 96" wide, 8" X-mem spacing	
	3097000457	20' Deck - 102" wide, 12" X-mem spacing	
	3097000461	20' Deck - 102" wide, 8" X-mem spacing	
	3097000265	21' Deck - 96" wide, 12" X-mem spacing	
	3097000297	21' Deck - 96" wide, 8" X-mem spacing	
	3097000458	21' Deck - 102" wide, 12" X-mem spacing	
	3097000462	21' Deck - 102" wide, 8" X-mem spacing	
2	7493000009	Marker Light Grommet	6
3	7590000249	Marker Light - Amber (Std)	4
	7590000239	Marker Light - Amber (LED)	
4	7590000245	Marker Light - Red (Std)	2
	7590000238	Marker Light - Red (LED)	
5	7493000010	Marker Light Grommet	2
6	7590000250	Marker Light - Amber (Std)	2
	7590000242	Marker Light - Amber (LED)	
7	7330000498	Reflector - Amber	8
8	7330000497	Reflector - Red	4

DECK - STEEL RUSTLER (WSRB)

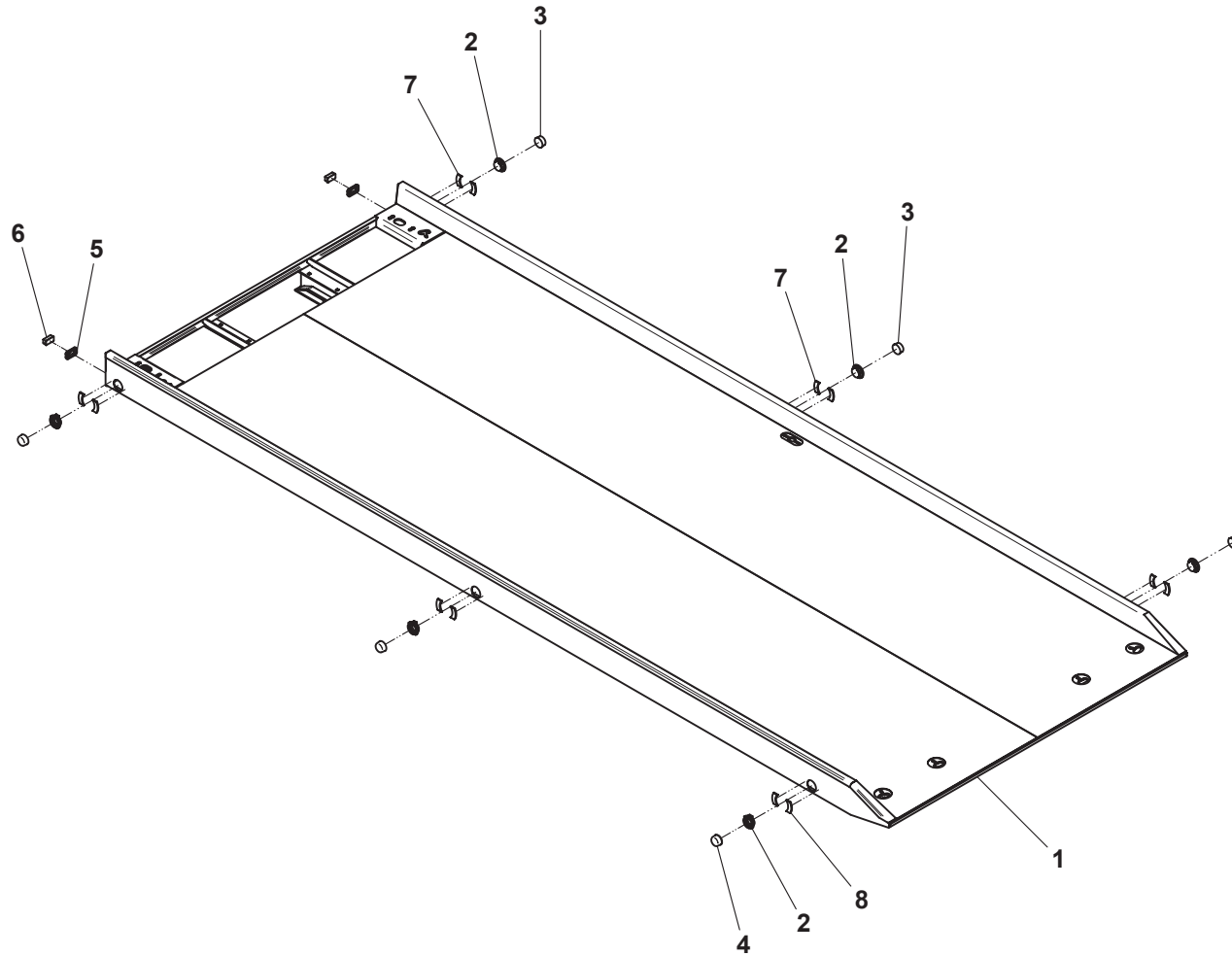

21' deck shown

DECK - STEEL B.I.C. (RRSB)

ITEM	PART NO.	DESCRIPTION	QTY	ITEM	PART NO.	DESCRIPTION	QTY
1	3097000270	19' Deck - 96" wide, 12" X-mem spacing	1			<i>Standard Steel Tubular Removable Rails:</i>	
	3097000281	19' Deck - 96" wide, 8" X-mem spacing					
	3097000448	19' Deck - 102" wide, 12" X-mem spacing		9	3729000115	Steel Rail, LH Front (19' & 20' decks)	1
	3097000452	19' Deck - 102" wide, 8" X-mem spacing			3729000126	Steel Rail, LH Front (21' deck)	
	3097000447	20' Deck - 96" wide, 12" X-mem spacing		10	3729000115	Steel Rail, RH Front (19' & 20' decks)	1
	3097000451	20' Deck - 96" wide, 8" X-mem spacing			3729000126	Steel Rail, RH Front (21' deck)	
	3097000449	20' Deck - 102" wide, 12" X-mem spacing		11	3729000129	Steel Rail, LH Rear (19' & 20' decks)	1
	3097000453	20' Deck - 102" wide, 8" X-mem spacing			3729000127	Steel Rail, LH Rear (21' deck)	
	3097000269	21' Deck - 96" wide, 12" X-mem spacing		12	3729000130	Steel Rail, RH Rear (19' & 20' deck)	1
	3097000284	21' Deck - 96" wide, 8" X-mem spacing			3729000128	Steel Rail, RH Rear (21' deck)	
	3097000450	21' Deck - 102" wide, 12" X-mem spacing		13	7120000005	Capscrew, 0.50"-13NC x 2.50"	10
	3097000454	21' Deck - 102" wide, 8" X-mem spacing				(19' & 20' decks)	
2	7493000009	Marker Light Grommet	6			Capscrew, 0.50"-13NC x 2.50" (21' deck)	12
3	7590000249	Marker Light - Amber (Std)	4	14	7701000033	End Cap	4
	7590000239	Marker Light - Amber (LED)					
4	7590000245	Marker Light - Red (Std)	2			<i>Optional Aluminum Removable Rails:</i>	
	7590000238	Marker Light - Red (LED)					
5	7493000010	Marker Light Grommet	2	9	3017000084	Aluminum Rail, LH Front	1
6	7590000250	Marker Light - Amber (Std)	2	10	3017000085	Aluminum Rail, RH Front	1
	7590000242	Marker Light - Amber (LED)		11	3017000088	Aluminum Rail, LH Rear (19' & 20' decks)	1
7	7330000498	Reflector - Amber	8		3017000086	Aluminum Rail, LH Rear (21' deck)	
8	7330000497	Reflector - Red	4	12	3017000089	Aluminum Rail, RH Rear (19' & 20' deck)	1
					3017000087	Aluminum Rail, RH Rear (21' deck)	
				13	7115181650	Capscrew, 0.50"-13NC x 2.00"	10
						(19' & 20' decks)	
						Capscrew, 0.50"-13NC x 2.00" (21' deck)	12
				14	Not Required		

DECK - STEEL B.I.C. (RRSB)

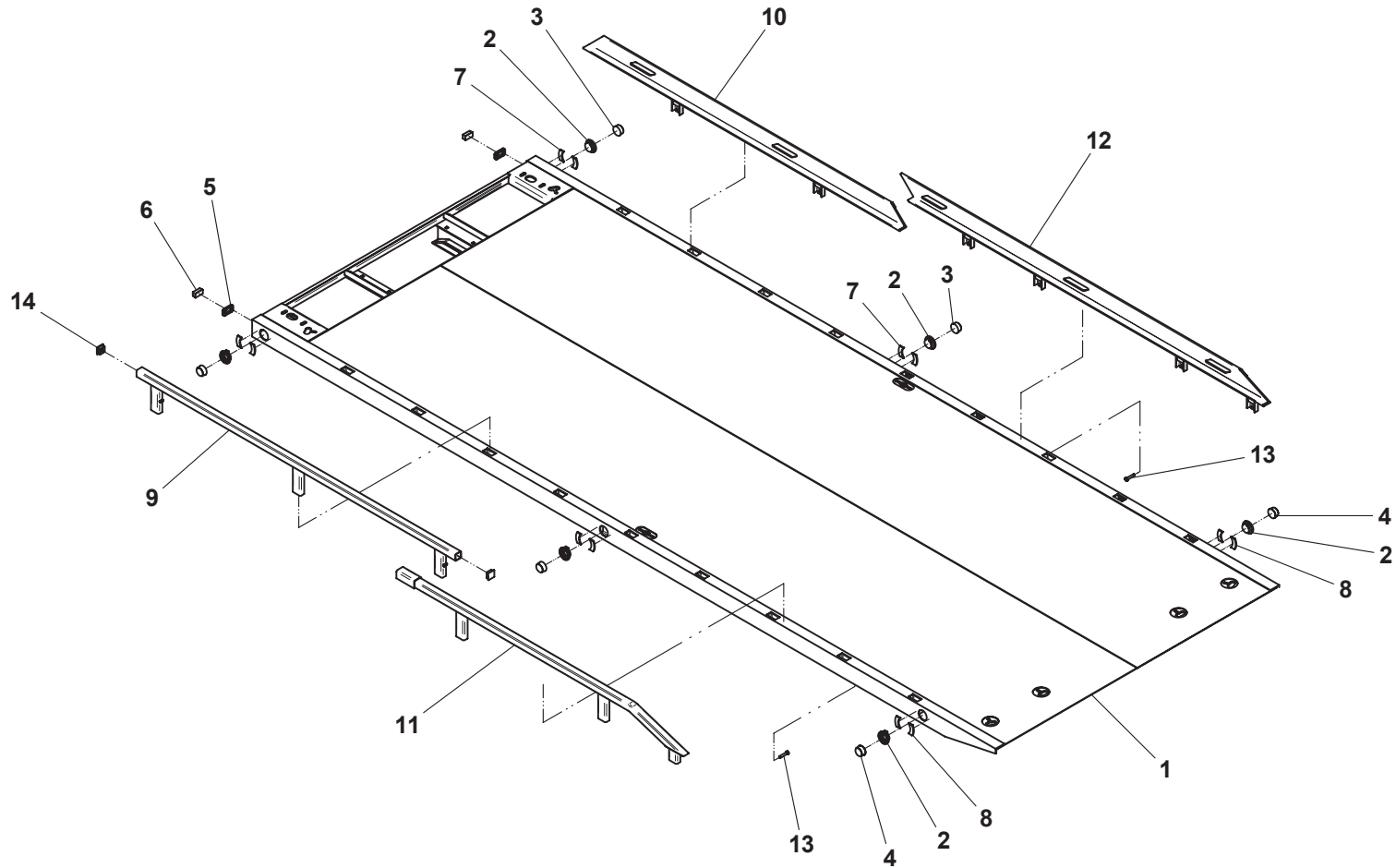

21' deck shown with standard removable steel rails on left side and optional aluminum removable rails on right side

DECK - STEEL SHARK (SLPB)

ITEM	PART NO.	DESCRIPTION	QTY
1	3097000266	19' Deck - 96" wide, 12" X-mem spacing	1
	3097000467	19' Deck - 96" wide, 8" X-mem spacing	
	3097000464	19' Deck - 102" wide, 12" X-mem spacing	
	3097000470	19' Deck - 102" wide, 8" X-mem spacing	
	3097000463	20' Deck - 96" wide, 12" X-mem spacing	
	3097000468	20' Deck - 96" wide, 8" X-mem spacing	
	3097000465	20' Deck - 102" wide, 12" X-mem spacing	
	3097000471	20' Deck - 102" wide, 8" X-mem spacing	
	3097000268	21' Deck - 96" wide, 12" X-mem spacing	
	3097000469	21' Deck - 96" wide, 8" X-mem spacing	
	3097000466	21' Deck - 102" wide, 12" X-mem spacing	
	3097000472	21' Deck - 102" wide, 8" X-mem spacing	
	2	7493000009	
3	7590000249	Marker Light - Amber (Std)	4
	7590000239	Marker Light - Amber (LED)	
4	7590000245	Marker Light - Red (Std)	2
	7590000238	Marker Light - Red (LED)	
5	7493000010	Marker Light Grommet	2
6	7590000250	Marker Light - Amber (Std)	2
	7590000242	Marker Light - Amber (LED)	
7	7330000498	Reflector - Amber	8
8	7330000497	Reflector - Red	4
9	4017000334	Aluminum Rail, LH (19' deck)	1
	4017001319	Aluminum Rail, LH (20' deck)	
	4017000834	Aluminum Rail, LH (21' deck)	
10	4017000345	Aluminum Rail, RH (19' deck)	1
	4017001320	Aluminum Rail, RH (20' deck)	
	4017000835	Aluminum Rail, RH (21' deck)	
11	7115181850	Capscrew, 0.50"-13NC x 2.25"	16
12	7660182601	Locknut, 0.50" ID	16

DECK - STEEL SHARK (SLPB)

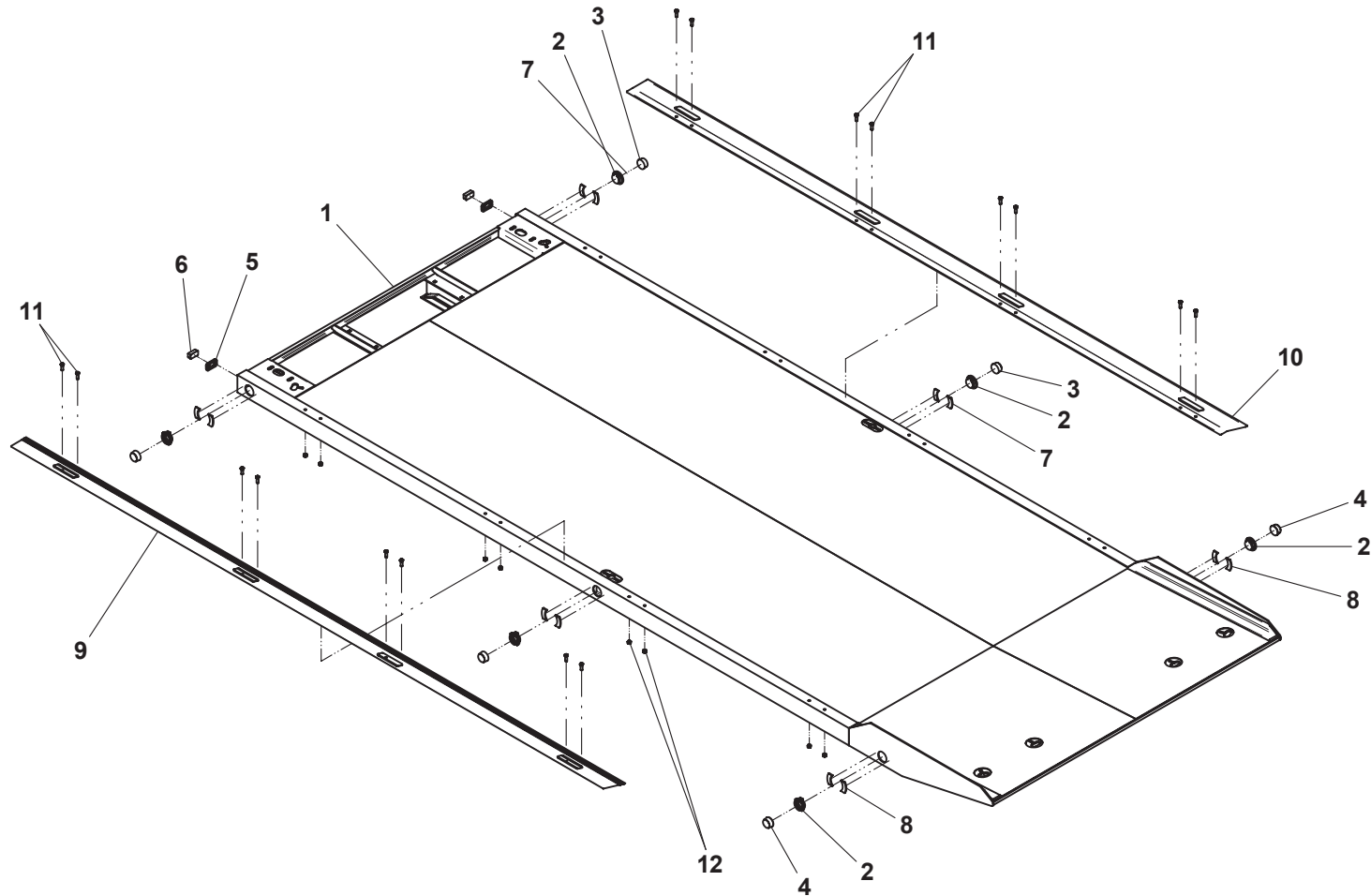

21' deck shown

DECK - STEEL B.I.C. TRANSPORTER (STRB)

ITEM	PART NO.	DESCRIPTION	QTY	ITEM	PART NO.	DESCRIPTION	QTY
1	3097000273	19' Deck - 95" wide, 12" X-mem spacing	1			<i>Optional Steel Tubular Removable Rails:</i>	
	3097000285	19' Deck - 95" wide, 8" X-mem spacing					
	3097000429	19' Deck - 102" wide, 12" X-mem spacing		11	3729000115	Steel Rail, LH Front (19' & 20' decks)	1
	3097000295	19' Deck - 102" wide, 8" X-mem spacing			3729000126	Steel Rail, LH Front (21' deck)	
	3097000430	20' Deck - 95" wide, 12" X-mem spacing		12	3729000115	Steel Rail, RH Front (19' & 20' decks)	1
	3097000432	20' Deck - 95" wide, 8" X-mem spacing			3729000126	Steel Rail, RH Front (21' deck)	
	3097000431	20' Deck - 102" wide, 12" X-mem spacing		13	3729000129	Steel Rail, LH Rear (19' & 20' decks)	1
	3097000433	20' Deck - 102" wide, 8" X-mem spacing			3729000127	Steel Rail, LH Rear (21' deck)	
	3097000274	21' Deck - 95" wide, 12" X-mem spacing		14	3729000130	Steel Rail, RH Rear (19' & 20' deck)	1
	3097000286	21' Deck - 95" wide, 8" X-mem spacing			3729000128	Steel Rail, RH Rear (21' deck)	
	3097000382	21' Deck - 102" wide, 12" X-mem spacing		15	7120000005	Capscrew, 0.50"-13NC x 2.50"	10
	3097000434	21' Deck - 102" wide, 8" X-mem spacing				(19' & 20' decks)	
2	7493000009	Marker Light Grommet	6			Capscrew, 0.50"-13NC x 2.50" (21' deck)	12
3	7590000249	Marker Light - Amber (Std)	4	16	7701000033	End Cap	4
	7590000239	Marker Light - Amber (LED)					
4	7590000245	Marker Light - Red (Std)	2			<i>Optional Aluminum Removable Rails:</i>	
	7590000238	Marker Light - Red (LED)					
5	7493000010	Marker Light Grommet	2				
6	7590000250	Marker Light - Amber (Std)	2	11	3017000084	Aluminum Rail, LH Front	1
	7590000242	Marker Light - Amber (LED)		12	3017000085	Aluminum Rail, RH Front	1
7	7330000498	Reflector - Amber	8	13	3017000088	Aluminum Rail, LH Rear (19' & 20' decks)	1
8	7330000497	Reflector - Red	4		3017000086	Aluminum Rail, LH Rear (21' deck)	
9	Contact Parts	Keruing Board	A/R	14	3017000089	Aluminum Rail, RH Rear (19' & 20' deck)	1
10	7786000007	Screw, 0.31"-18NC x 2.00"	A/R		3017000087	Aluminum Rail, RH Rear (21' deck)	
				15	7115181650	Capscrew, 0.50"-13NC x 2.00"	10
						(19' & 20' decks)	
						Capscrew, 0.50"-13NC x 2.00" (21' deck)	12
				16	Not Required		

DECK - STEEL B.I.C. TRANSPORTER (STRB)

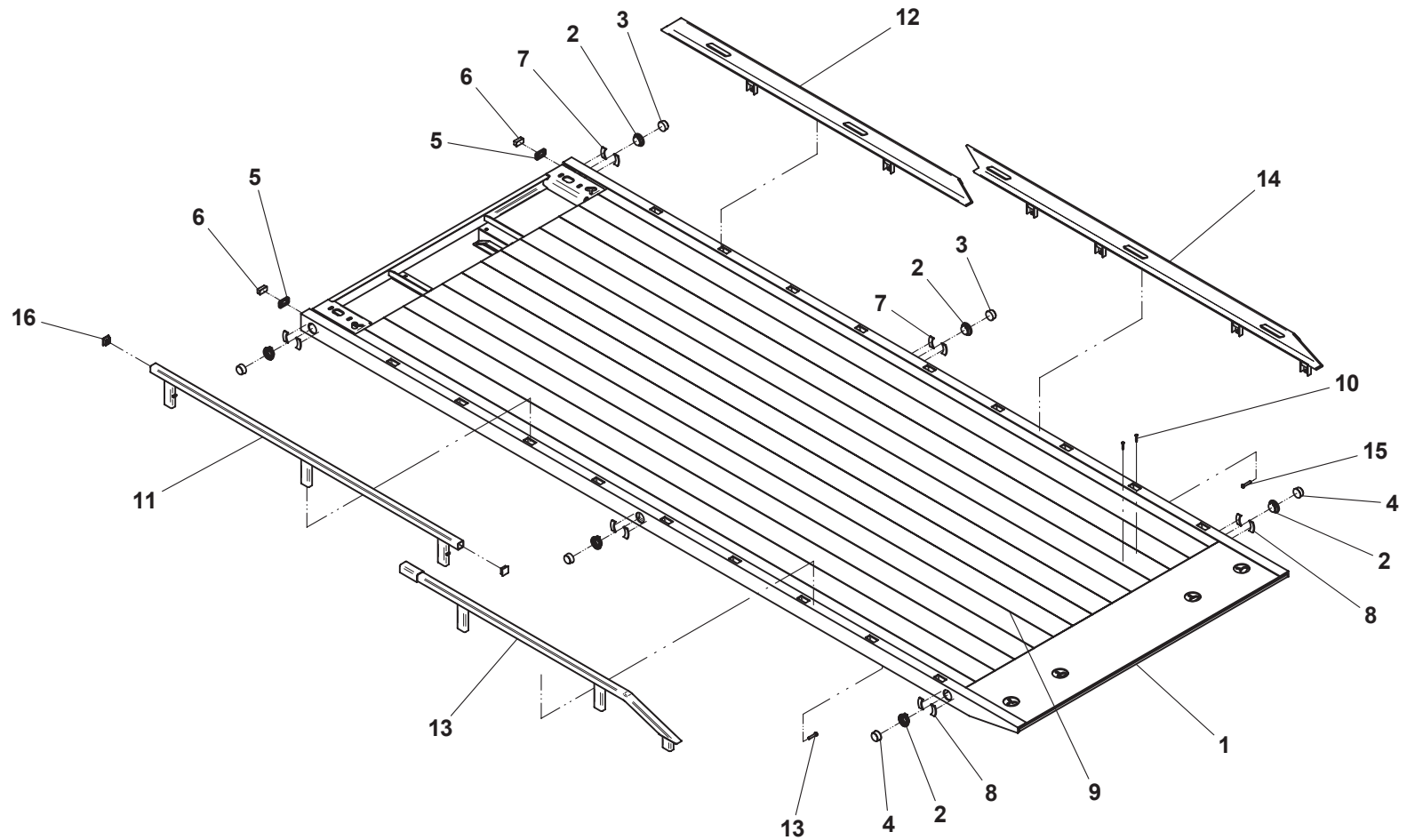

21' deck shown with optional removable steel rails on left side and optional aluminum removable rails on right side

STANDARD HEADBOARD & WINCH FREE SPOOL

ITEM	PART NO.	DESCRIPTION	QTY
1	3241000139	Standard Headboard Weld - 36.50"	1
	3241000140	Standard Headboard Weld - 40.50"	
	3241000141	Standard Headboard Weld - 45.50"	
	3241000142	Standard Headboard Weld - 50.50"	
	3241000143	Standard Headboard Weld - 57.50"	
2	4796000037	Gasket	2
3	7105201650	Capscrew, 0.63"-18NF x 2.00"	4
4	7950200152	Flatwasher, 0.63" ID	4
5	7660200035	Nut, 0.63"-18NF	2
6	4178000671*	Bracket	1
7	4209000328*	Bushing	1
8	7082000010*	Nylon Washer	2
9	7950180161*	Flatwasher, 0.50" ID	1
10	7990000011*	Yoke	1
11	7691000046*	Clevis Pin	2
12	7082000009*	Bearing Flange	1
13	7950180143*	Flatwasher, 0.50" ID	3
14	4763000348*	Rod	1
15	7660180234*	Nut, 0.50"-20NF	1
16	4178000673*	Bracket	1
17	7115150850*	Capscrew, 0.31"-18NC x 1.00"	2
18	7950150161*	Flatwasher, 0.31" ID	4
19	7660152601*	Locknut, 0.31"-18NC	2
20	4209000147*	Bushing (worm gear winch)	1
	4209000145*	Bushing (planetary gear winch)	
21	7690051274*	Pin	2
22	7949000030*	Nylon Washer	1
23	7843000027*	Spring	1
24	7551000017*	Knob	1
25	4632000009*	Trim Lok	1

* also available in complete Remote Free Spool Installation:
P/N 2970000021 for 8,000 / 10,000 lb worm gear winch
P/N 2970000019 for 8,000 lb planetary gear winch

STANDARD HEADBOARD & WINCH FREE SPOOL

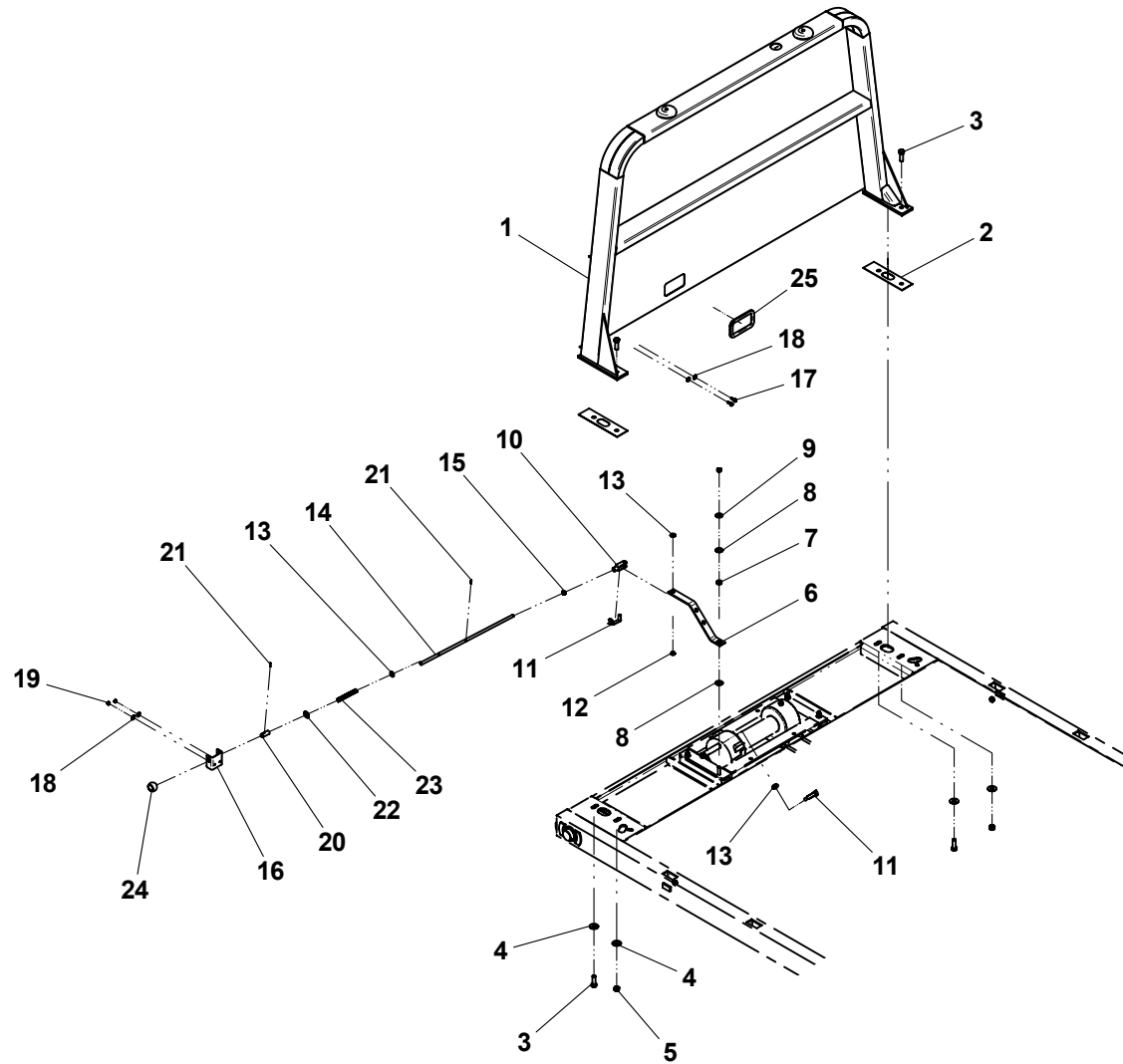

50.50" headboard shown with 8,000 lb worm gear winch

DELUXE HEADBOARD & WINCH FREE SPOOL

ITEM	PART NO.	DESCRIPTION	QTY	ITEM	PART NO.	DESCRIPTION	QTY
1	3241000132	Deluxe Headboard Weld - 36.50"	1	24	7690051274*	Pin	2
	3241000133	Deluxe Headboard Weld - 40.50"		25	7949000030*	Nylon Washer	1
	3241000134	Deluxe Headboard Weld - 45.50"		26	7843000027*	Spring	1
	3241000135	Deluxe Headboard Weld - 50.50"		27	7551000017*	Knob	1
	3241000136	Deluxe Headboard Weld - 57.50"		28	4632000009*	Trim Lok	1
2	4796000037	Gasket	2				
3	7105201650	Capscrew, 0.63"-18NF x 2.00"	4				
4	7950200152	Flatwasher, 0.63" ID	4				
5	7660200035	Nut, 0.63"-18NF	2				
6	3391000014	Screen Weld	1				
		(36.50", 40.50" & 45.50" headboards)					
	3391000017	Screen Weld (50.50" headboard)					
	3391000018	Screen Weld (57.50" headboard)					
7	4796000003	Gasket	1				
8	7759000015	Rivet	6				
9	4178000671*	Bracket	1				
10	4209000328*	Bushing	1				
11	7082000010*	Nylon Washer	2				
12	7950180161*	Flatwasher, 0.50" ID	1				
13	7990000011*	Yoke	1				
14	7691000046*	Clevis Pin	2				
15	7082000009*	Bearing Flange	1				
16	7950180143*	Flatwasher, 0.50" ID	3				
17	4763000252*	Rod	1				
18	7660180234*	Nut, 0.50"-20NF	1				
19	4178000673*	Bracket	1				
20	7115150850*	Capscrew, 0.31"-18NC x 1.00"	2				
21	7950150161*	Flatwasher, 0.31" ID	4				
22	7660152601*	Locknut, 0.31"-18NC	2				
23	4209000147*	Bushing (worm gear winch)	1				
	4209000145*	Bushing (planetary gear winch)					

* also available in Remote Free Spool Installation:
 P/N 2970000021 for 8,000 / 10,000 lb worm gear winch
 P/N 2970000019 for 8,000 lb planetary gear winch

DELUXE HEADBOARD & WINCH FREE SPOOL

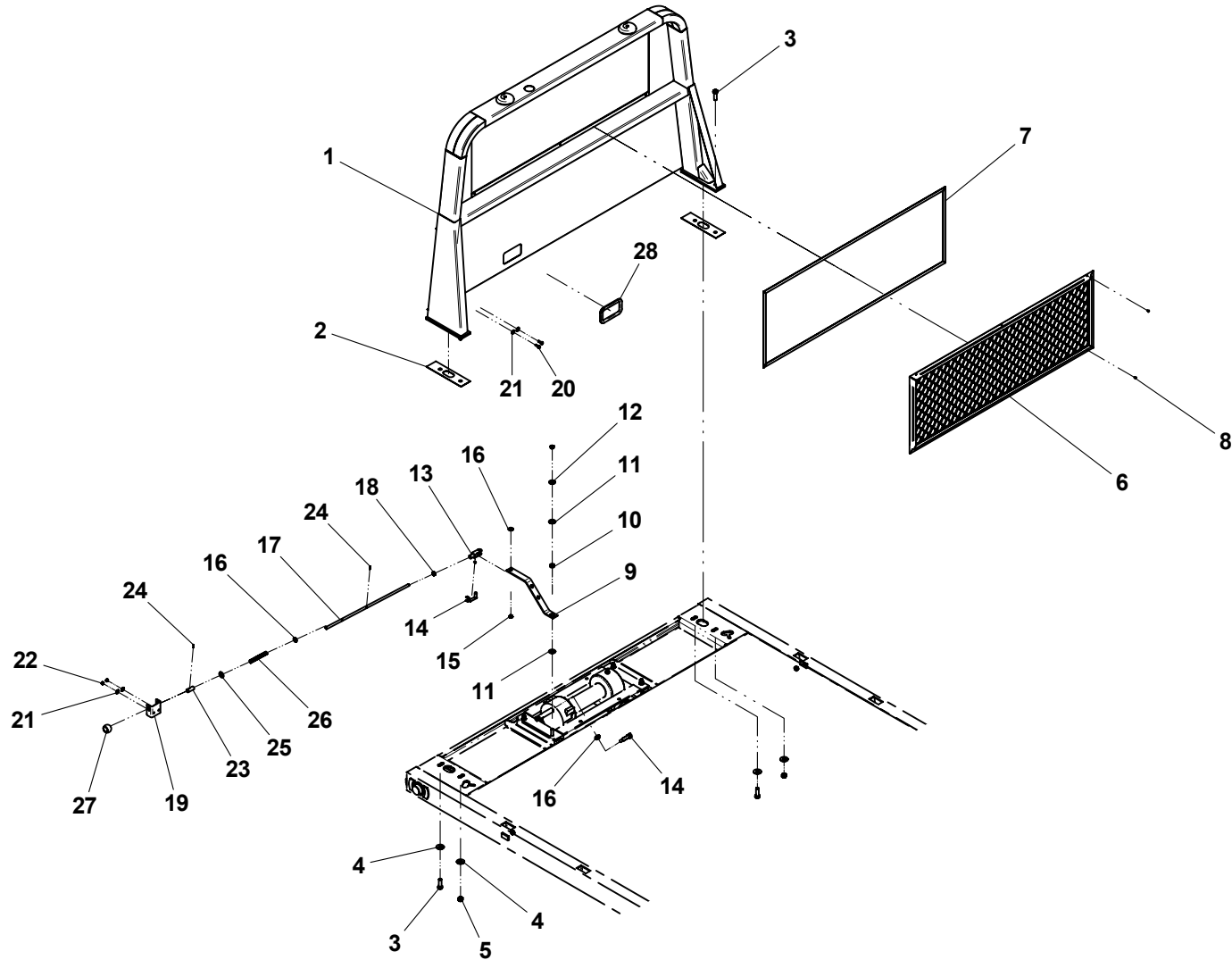

50.50" headboard shown with 8,000 lb worm gear winch

STATIONARY HEADBOARD & WINCH FREE SPOOL

ITEM	PART NO.	DESCRIPTION	QTY	ITEM	PART NO.	DESCRIPTION	QTY
1	3241000161	Stationary Headboard Weld - 57.00"	1	26	7690051274*	Pin	2
	3241000162	Stationary Headboard Weld - 62.00"		27	7949000030*	Nylon Washer	1
	3241000163	Stationary Headboard Weld - 69.00"		28	7843000027*	Spring	1
2	7105181450	Capscrew, 0.50"-20NF x 1.75"	8	29	7551000017*	Knob	1
3	7950180153	Flatwasher, 0.50" ID	8				
4	7660182631	Locknut, 0.50"-20NF	8				
5	3391000014	Screen Weld (57.00" headboard)	1				
	3391000017	Screen Weld (62.00" headboard)					
	3391000018	Screen Weld (69.00" headboard)					
6	4796000003	Gasket	1				
7	7759000015	Rivet	6				
8	4705000607	Shim - 0.25"	A/R				
9	4705000608	Shim - 0.12"	A/R				
10	4178000672*	Bracket	1				
11	4209000328*	Bushing	1				
12	7082000010*	Nylon Washer	2				
13	7950180161*	Flatwasher, 0.50" ID	1				
14	7990000011*	Yoke	1				
15	7691000046*	Clevis Pin	2				
16	7082000009*	Bearing Flange	1				
17	7950180143*	Flatwasher, 0.50" ID	3				
18	4763000252*	Rod	1				
19	7660180234*	Locknut, 0.50"-20NF	1				
20	4178000674*	Bracket (steel decks)	1				
	4017001499*	Bracket (aluminum decks)					
21	4178000673*	Bracket	1				
22	7115150850*	Capscrew, 0.31"-18NC x 1.00"	2				
23	7950150161*	Flatwasher, 0.31" ID	4				
24	7660152601*	Locknut, 0.31"-18NC	2				
25	4209000147*	Bushing (worm gear winch)	1				
	4209000145*	Bushing (planetary gear winch)					

* also available in complet Remote Free Spool Installation:
P/N 2970000021 for 8,000 / 10,000 lb worm gear winch
P/N 2970000019 for 8,000 lb planetary gear winch

STATIONARY HEADBOARD & WINCH FREE SPOOL

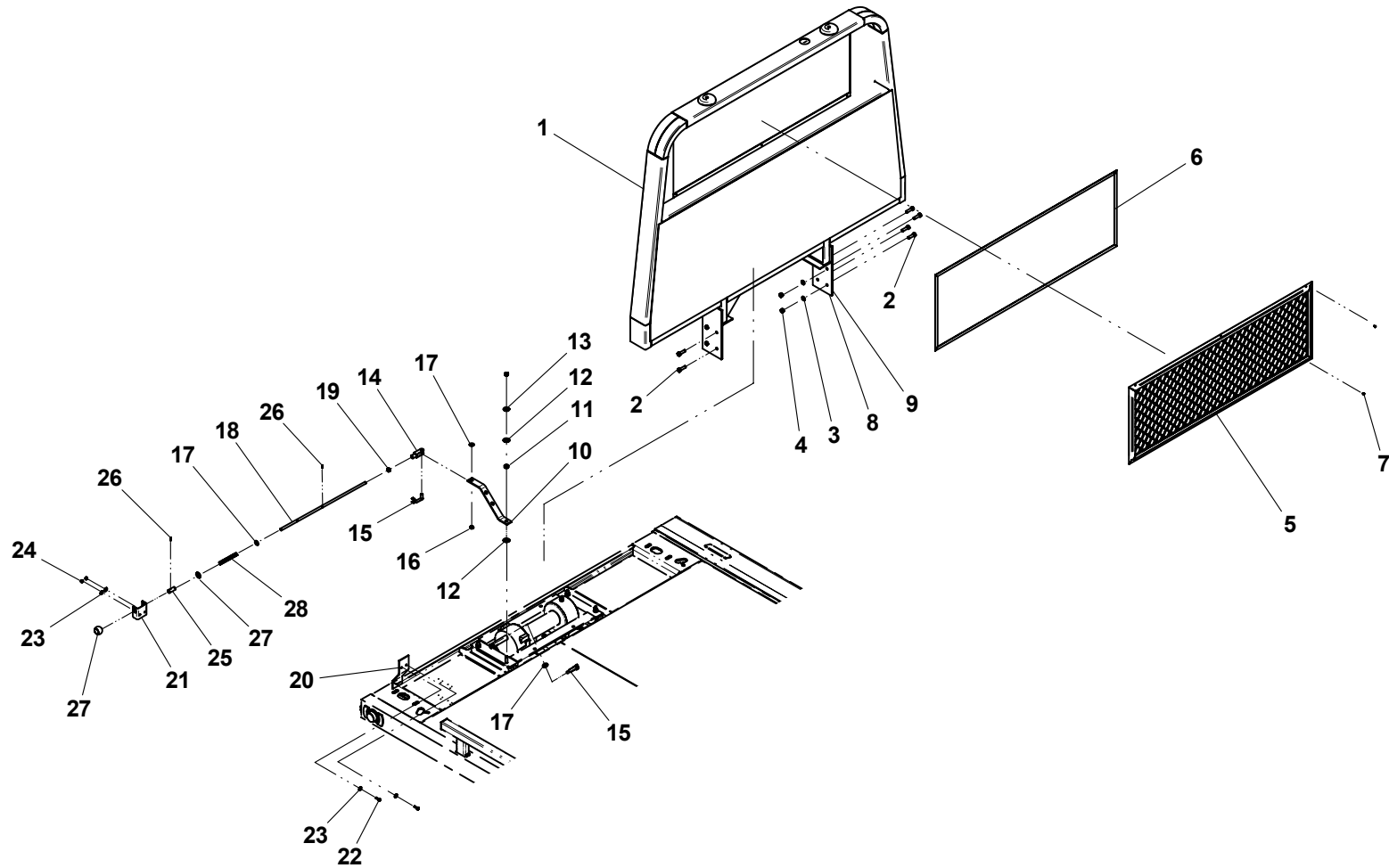

62.00" headboard shown with 8,000 lb worm gear winch

WORM GEAR WINCH

ITEM	PART NO.	DESCRIPTION	QTY		
1	7970000121	Winch - 8,000 lb Worm Gear	1		
	7970000123	Winch - 10,000 lb Worm Gear			
2	7626000014	Orbit Motor	1		
3	9970414952	Capscrew, 0.50"-13NC x 1.25"	2		
4	7950180400	Lockwasher, 0.50" ID	2		
5	7115181464	Carriage Bolt, 0.50"-13NC x 1.75" (steel decks)	3		
	7115182864	Carriage Bolt, 0.50"-13NC x 3.5" (steel transporters)			
	7115181864	Carriage Bolt, 0.50"-13NC x 2.25" (aluminum decks)			
	7115183264	Carriage Bolt, 0.50"-13NC x 4.00" (aluminum transporters)			
	6	7115181864		Carriage Bolt, 0.50"-13NC x 2.25" (steel decks)	1
		7115183264		Carriage, 0.50"-13NC x 4.00" (steel transporters)	
		7115182264		Carriage Bolt, 0.50"-13NC x 2.75" (aluminum decks)	
	7115183664	Capscrew, 0.50"-13NC x 4.50" (aluminum transporters)			
7	7950180153	Flatwasher, 0.50" ID	4		
8	7660182601	Locknut, 0.50"-13NC	4		
9	4062000318	Bar (transporters only)	2		
10	7248000063	Cable, 0.38" dia x 56' (8,000lb winch)	1		
	7248000064	Cable, 0.44" dia x 56' (10,000lb winch)			

Refer to manufacturer's manual for winch parts list

WORM GEAR WINCH

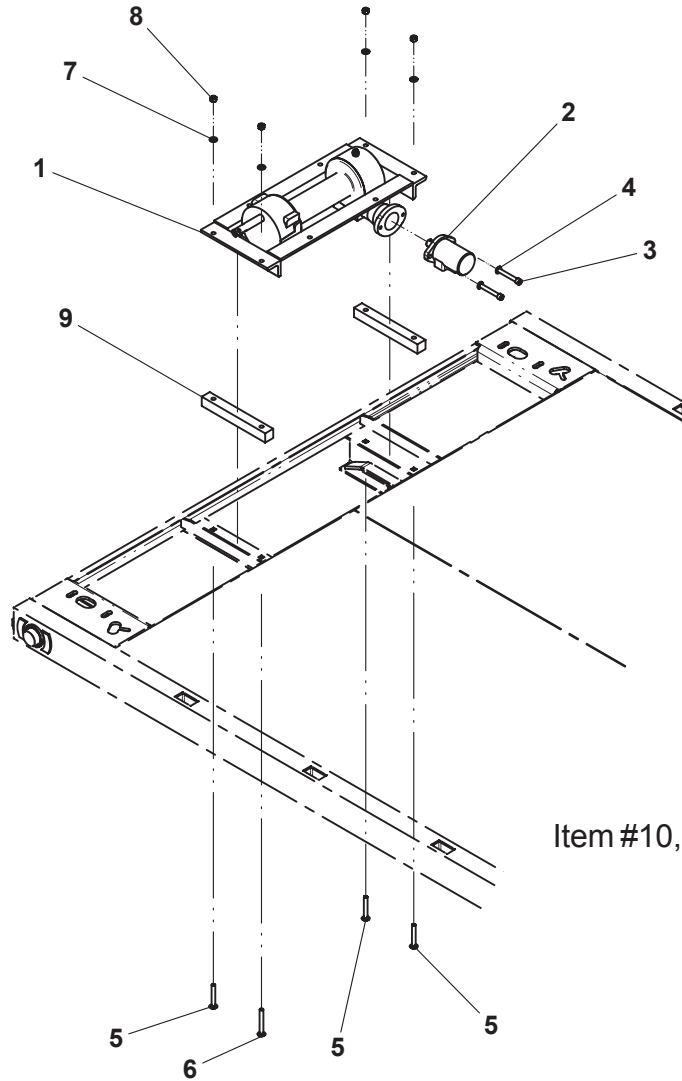

Item #10, Winch Cable, not shown

8,000 lb winch shown on transporter deck

PLANETARY GEAR WINCH

ITEM	PART NO.	DESCRIPTION	QTY
1	7970000056	Winch - 8,000 lb Planetary Gear	1
2	7115181464	Carriage Bolt, 0.50"-13NC x 1.75" (steel decks)	3
	7115182864	Carriage Bolt, 0.50"-13NC x 3.50" (steel transporters)	
	7115181864	Carriage Bolt, 0.50"-13NC x 2.25" (aluminum decks)	
	7115183264	Carriage Bolt, 0.50"-13NC x 4.00" (aluminum transporters)	
3	7115181864	Carriage Bolt, 0.50"-13NC x 2.25" (steel decks)	1
	7115183264	Carriage, 0.50"-13NC x 4.00" (steel transporters)	
	7115182264	Carriage Bolt, 0.50"-13NC x 2.75" (aluminum decks)	
	7115183664	Capscrew, 0.50"-13NC x 4.50" (aluminum transporters)	
4	7950180153	Flatwasher, 0.50" ID	4
5	7660182601	Locknut, 0.50"-13NC	4
6	4062000318	Bar (transporters only)	2
7	7248000063	Cable, 0.38" dia x 56'	1

Refer to manufacturer's manual for winch parts list

PLANETARY GEAR WINCH

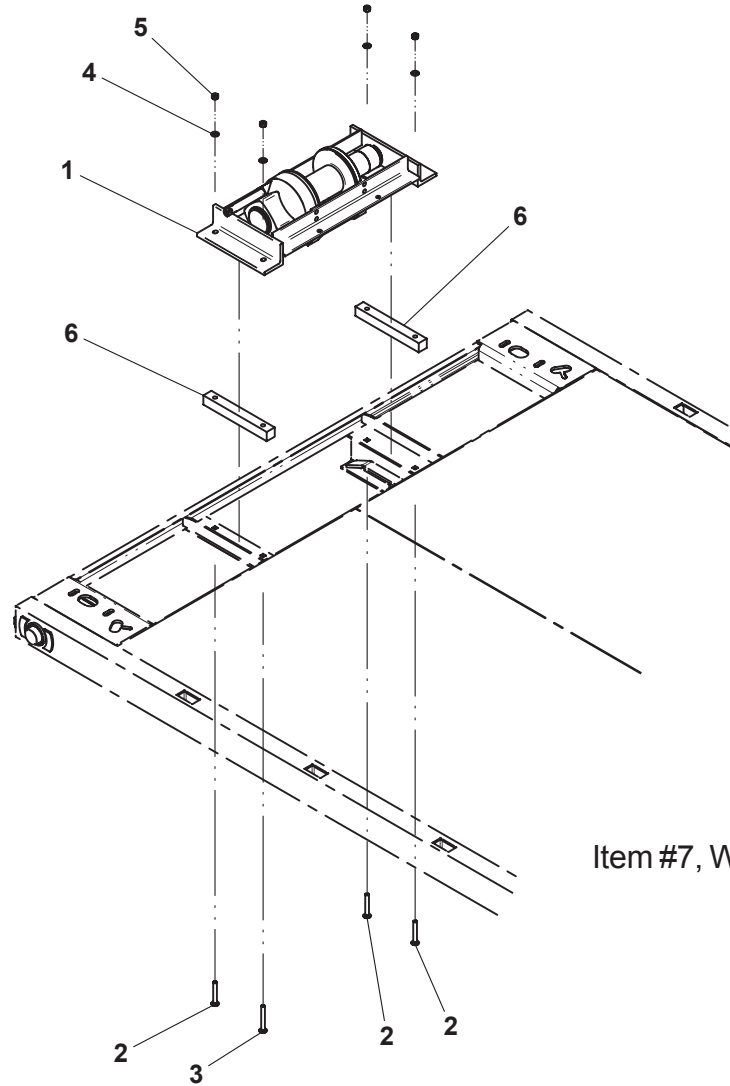

Item #7, Winch Cable, not shown

8,000 lb winch shown on transporter deck

WORM GEAR WINCH CABLE ROLLER GUIDE / TENSIONER PLATE

ITEM	PART NO.	DESCRIPTION	QTY
1	3178000433*	Bracket Weld	1
2	7115181464	Carriage Bolt, 0.50"-13NC x 1.75"	4
3	7950180153	Flatwasher, 0.50" ID	4
4	7660182601	Locknut, 0.50"-13NC	4
5	4706003766	Plate	1
6	7843000035	Spring	2
7	4912000130*	Roller	1
8	4806000014*	Shaft	1
9	4912000394*	Roller	2
10	4806000011*	Shaft	2
11	7209000011*	Bushing	6
12	7949000034*	Spacer	4
13	7754000022*	Retaining Ring	6

* also available in Cable Guide / Tensioner Assembly, P/N 3249000036

WORM GEAR WINCH CABLE ROLLER GUIDE / TENSIONER PLATE

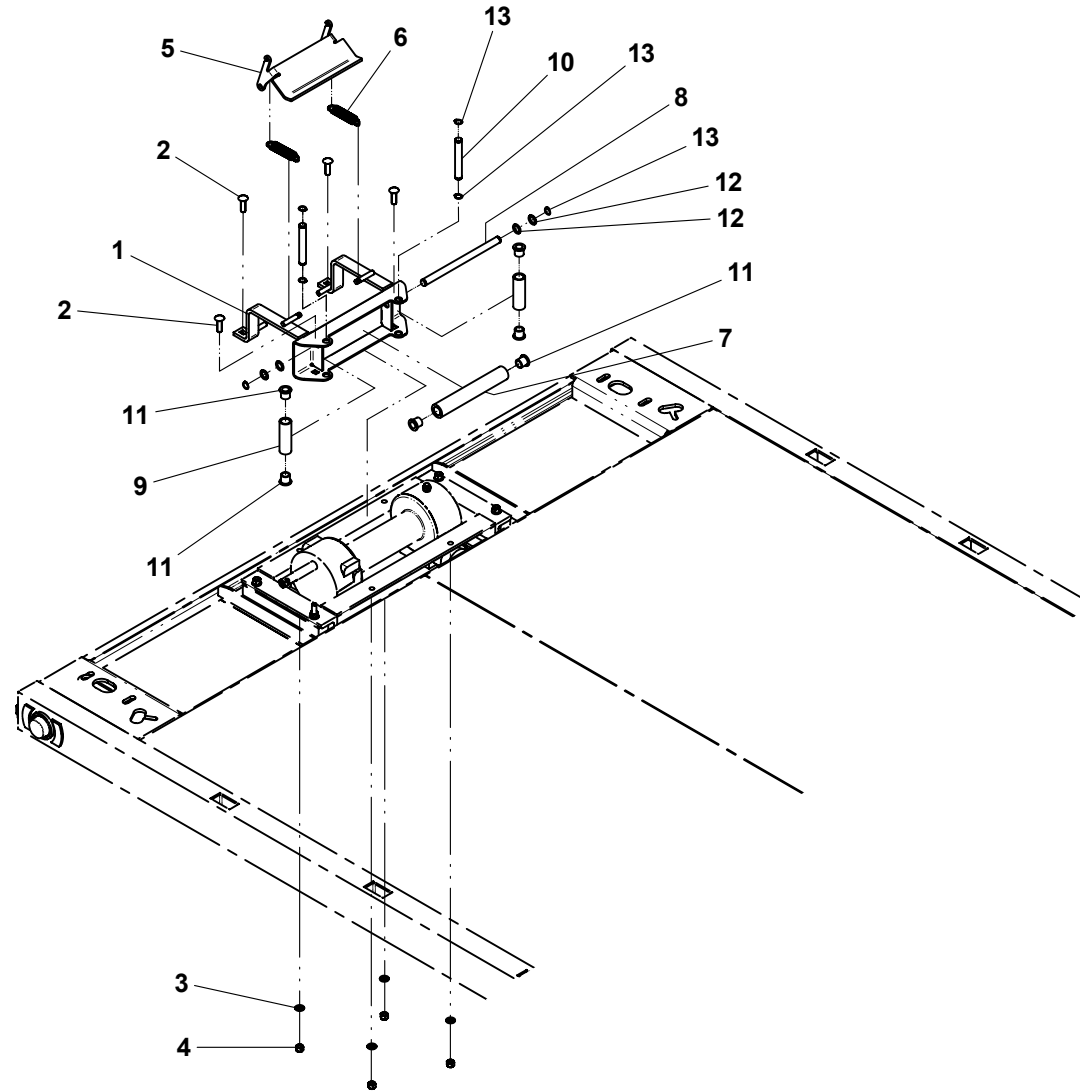

8,000 lb winch shown

PLANETARY GEAR WINCH CABLE ROLLER GUIDE / TENSIONER PLATE

ITEM	PART NO.	DESCRIPTION	QTY
1	3178000347	Bracket Weld	1
2	7115181050	Capscrew, 0.50"-13NC x 1.25"	2
3	7115180850	Capscrew, 0.50"-13NC x 1.00"	4
4	7950180153	Flatwasher, 0.50" ID	6
5	4706003792	Plate	1
6	7843000035	Spring	2
7	4912000345*	Roller	1
8	4691000421*	Shaft	1
9	7209000011*	Bushing	2
10	7949000034*	Spacer	2
11	7754000022*	Retaining Ring	2

* also available in Cable Guide / Tensioner Assembly, P/N 3249000019

PLANETARY GEAR WINCH CABLE ROLLER GUIDE / TENSIONER PLATE

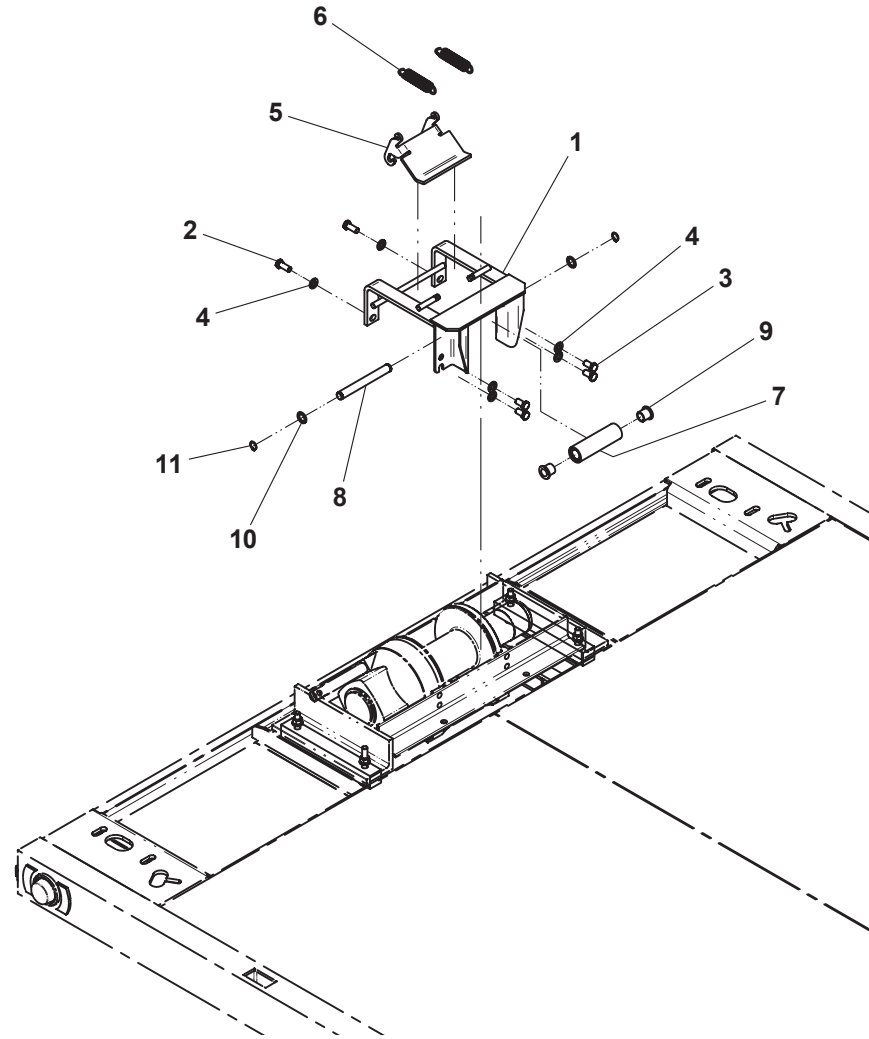

8,000 lb winch shown

SUBFRAME (OUTBOARD TILT CYLINDERS)

ITEM	PART NO.	DESCRIPTION	QTY	ITEM	PART NO.	DESCRIPTION	QTY
1	3868000268	Subframe Weld - Standard	1	24	7950180153	Flatwasher, 0.50 ID	8
	3868000270	Subframe Weld - Ford F550 & GM C4500/5500		25	7660182631	Locknut, 0.50"-20NF	8
	3868000275	Subframe Weld - Standard w/ 156" CA		26	3178000234*	Light Box, RH	1
2	3905000003	Trunnion Weld - Standard	1	27	3178000233*	Light Box, LH	1
	3905000009	Trunnion Weld - Ford F550 & GM C4500/5500		28	4017001294*	Mud Flap Angle, RH	1
				29	4017001293*	Mud Flap Angle, LH	1
3	4497000358	Gusset	2				
	4497000549	Gusset - Ford F550 only					
4	7082000017*	Bearing	4				
5	4691000295	Pin	2				
6	7949000008	Washer, 2.25" ID	2				
7	7118162250	Capscrew, 0.38"-16NC x 2.75"	2				
8	7660162601	Locknut, 0.38"-16NC	6				
9	4178000259	Bracket	2				
	3178000302	Bracket Weld (narrow chassis frame)					
10	3320000113	Tilt Cylinder Assembly	2				
11	3691000158	Pin Weld	2				
12	3691000073	Pin Weld	2				
13	4209000244	Bushing	4				
14	7115160950	Capscrew, 0.38"-16NC x 1.12"	4				
15	3320000112	Roll Cylinder Assembly	1				
16	4691000429	Pin	1				
17	7754000006	Retaining Ring	2				
18	4679000151	Pad	1				
19	4178000367	Bracket	1				
20	7660182601	Locknut, 0.50"-13NC	2				
21	7701000048*	Plug	4				
22	7701000051*	Plug	4				
23	7105181450	Capscrew, 0.50"-20NF x 1.75"	8				

* included in Subframe Welds, P/Ns 3868000268, 3868000270 and 3868000275

SUBFRAME (OUTBOARD TILT CYLINDERS)

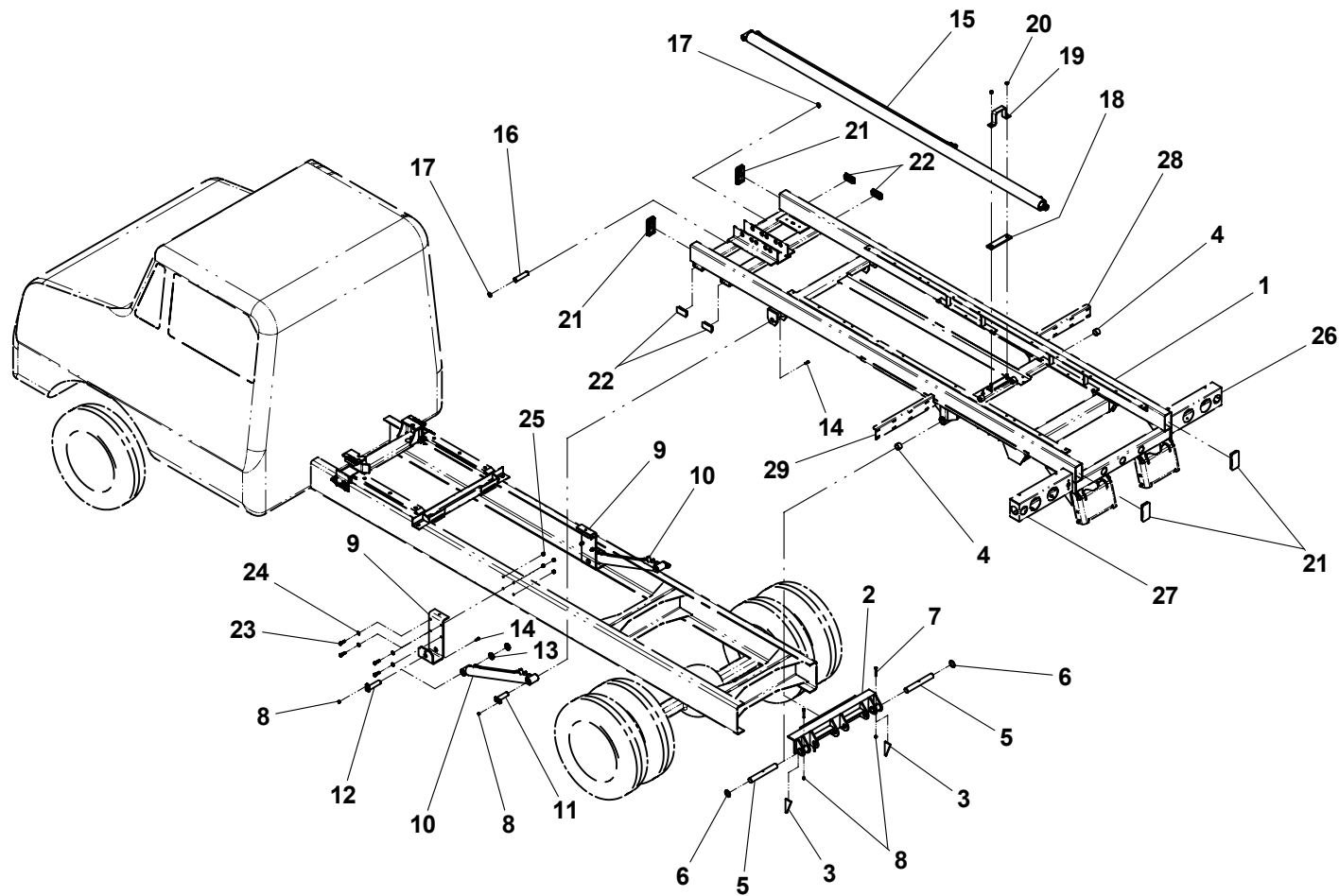

SUBFRAME (INBOARD TILT CYLINDERS)

ITEM	PART NO.	DESCRIPTION	QTY
1	3868000269	Subframe Weld	1
2	3905000003	Trunnion Weld	1
3	4497000358	Gusset	2
4	7082000017*	Bearing	4
5	4691000295	Pin	2
6	7949000008	Washer, 2.25" ID	2
7	7118162250	Capscrew, 0.38"-16NC x 2.75"	2
8	7660162601	Locknut, 0.38"-16NC	6
9	3316000054	Crossmember Weld	1
10	3320000120	Tilt Cylinder Assembly	2
11	3691000073	Pin Weld	4
12	7115160950	Capscrew, 0.38"-16NC x 1.12"	4
13	3320000112	Roll Cylinder Assembly	1
14	4691000429	Pin	1
15	7754000006	Retaining Ring	2
16	4679000151	Pad	1
17	4178000367	Bracket	1
18	7660182601	Locknut, 0.50"-13NC	2
19	7701000048*	Plug	4
20	7701000051*	Plug	4
21	7105181450	Capscrew, 0.50"-20NF x 1.75"	8
22	7950180153	Flatwasher, 0.50 ID	8
23	7660182631	Locknut, 0.50"-20NF	8
24	3178000234*	Light Box, RH	1
25	3178000233*	Light Box, LH	1
26	4017001294*	Mud Flap Angle, RH	1
27	4017001293*	Mud Flap Angle, LH	1
28	4705000507	Spacer	4

* included in Subframe Weld, P/N 3868000269

SUBFRAME (INBOARD TILT CYLINDERS)

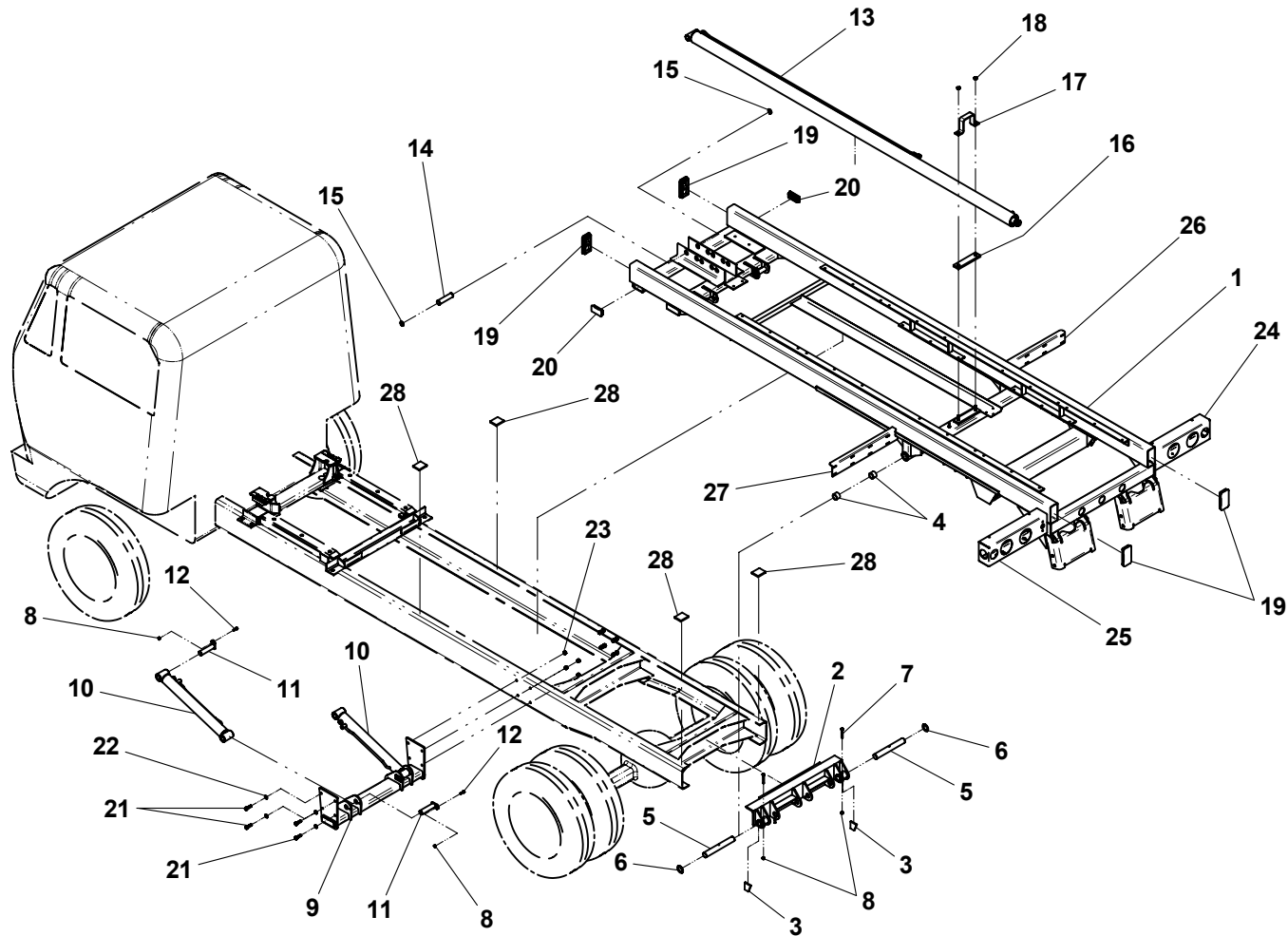

HOLD DOWN (OUTBOARD TILT CYLINDERS)

ITEM	PART NO.	DESCRIPTION	QTY
1	3558000013*	Hold Down Weld	1
	3558000015^	Hold Down Weld (narrow chassis frame)	
2	4017001271	Angle	2
3	7105181450	Capscrew, 0.50"-20NF x 1.75"	8
4	7950180153	Flatwasher, 0.50" ID	12
5	7660182631	Locknut, 0.50-20NF	8
6	7274000046	Retaining Clamp	2
7	7105201850	Capscrew, 0.63"-18NF x 2.25"	4
8	7660202348	Locknut, 0.63"-18NF	4
9	7701000063	Plug	4
10	4679000153*^	Wear Pad	2
11	7118161026*^	Flathead Screw, 0.38"-16NC x 1.25"	6
12	7660162601*^	Locknut, 0.38-16NC	6
13	4679000221*^	Wear Pad	2
14	4812000071*^	Shim - 0.12"	2
15	4812000072*^	Shim - 0.06"	2
16	7114151218*^	Capscrew, 0.31"-18NC x 1.50"	4
17	7660152601*^	Locknut, 0.31"-18NC	4

* also available in Hold Down Assembly, P/N 3558000014

^ also available in Hold Down Assembly, P/N 3558000016

HOLD DOWN (OUTBOARD TILT CYLINDERS)

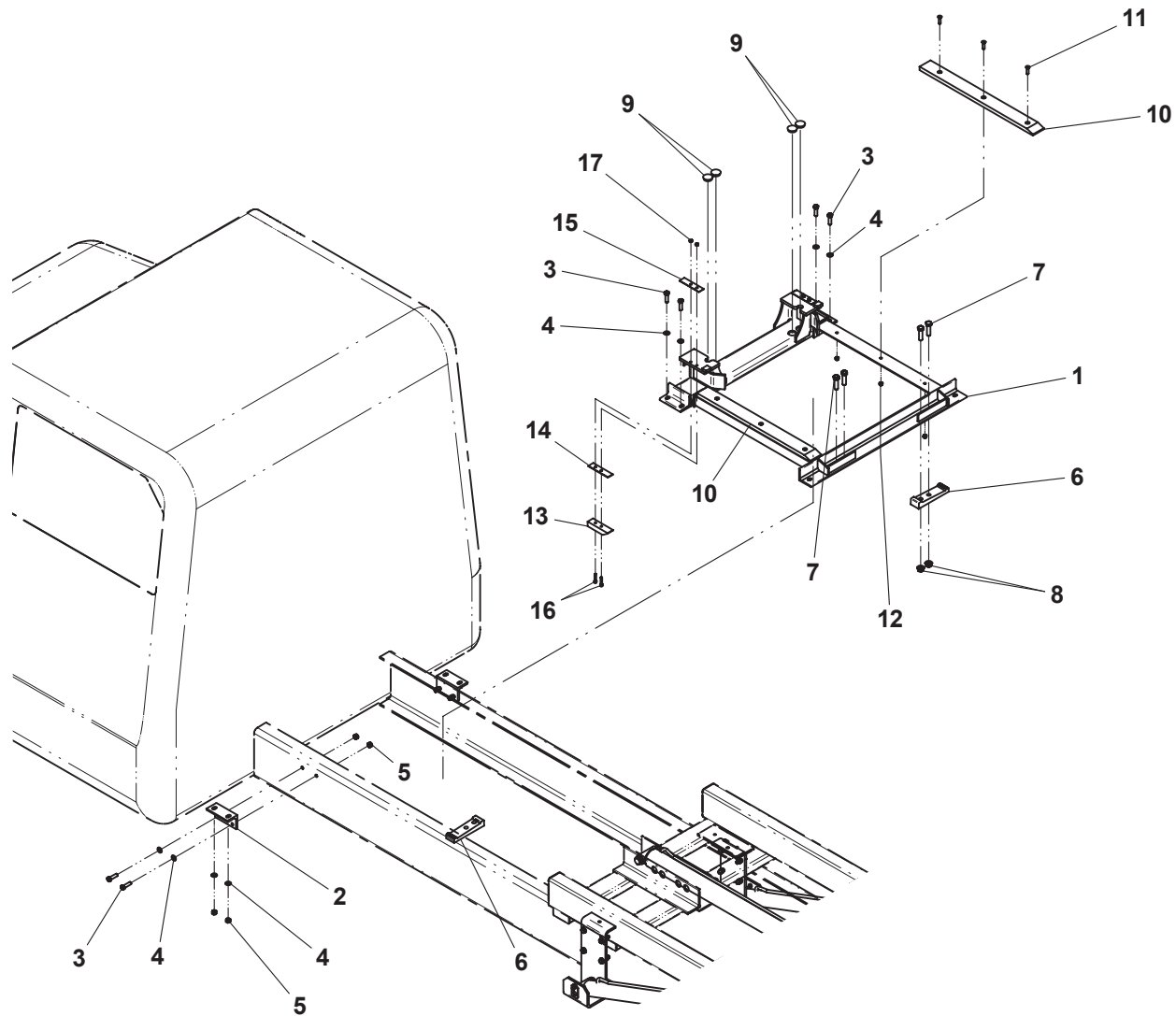

HOLD DOWN (INBOARD TILT CYLINDERS)

ITEM	PART NO.	DESCRIPTION	QTY
1	3558000013*	Hold Down Weld	1
2	4017001250	Angle	2
3	7105181450	Capscrew, 0.50"-20NF x 1.75"	2
4	7660182631	Locknut, 0.50-20NF	2
5	7274000046	Retaining Clamp	2
6	7105202250	Capscrew, 0.63"-18NF x 2.75"	4
7	7660202347	Locknut, 0.63"-18NF	4
8	7701000063	Plug	4
9	4679000153*	Wear Pad	2
10	7118161026*	Flathead Screw, 0.38"-16NC x 1.25"	6
11	7660162601*	Locknut, 0.38-16NC	6
12	4679000221*	Wear Pad	2
13	4812000071*	Shim - 0.12"	2
14	4812000072*	Shim - 0.06"	2
15	7114151218*	Capscrew, 0.31"-18NC x 1.50"	4
16	7660152601*	Locknut, 0.31"-18NC	4
17	4062000281	Spacer	2

* also available in Hold Down Assembly, P/N 3558000014

HOLD DOWN (INBOARD TILT CYLINDERS)

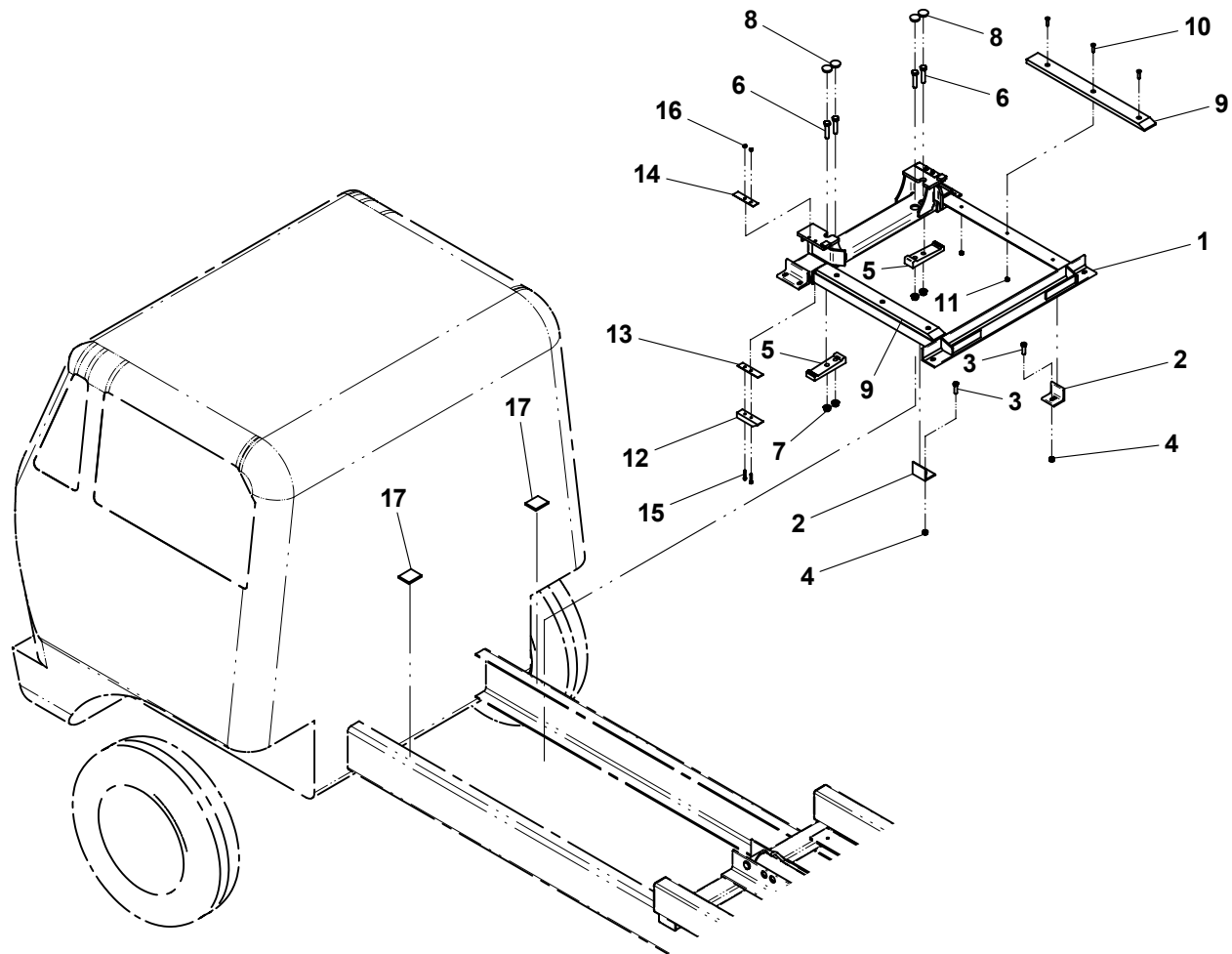

SLIDE PAD

ITEM	PART NO.	DESCRIPTION	QTY
1	4679000145*^	Wear Pad	12
2	4679000154^	Wear Pad (20' & 21' decks only)	2
3	7118161026*	Screw, 0.38"-16NC x 1.25" (19' decks)	36
	7118161026^	Screw, 0.38"-16NC x 1.25" (20' & 21' decks)	40
4	7660162601*	Locknut, 0.38"-16NC (19' decks)	36
	7660162601^	Locknut, 0.38"-16NC (20' & 21' decks)	40

* included in Wear Pad Kit P/N 9577000226 for 19' decks

^ included in Wear Pad Kit P/N 9577000227 for 20' & 21' decks

SLIDE PAD

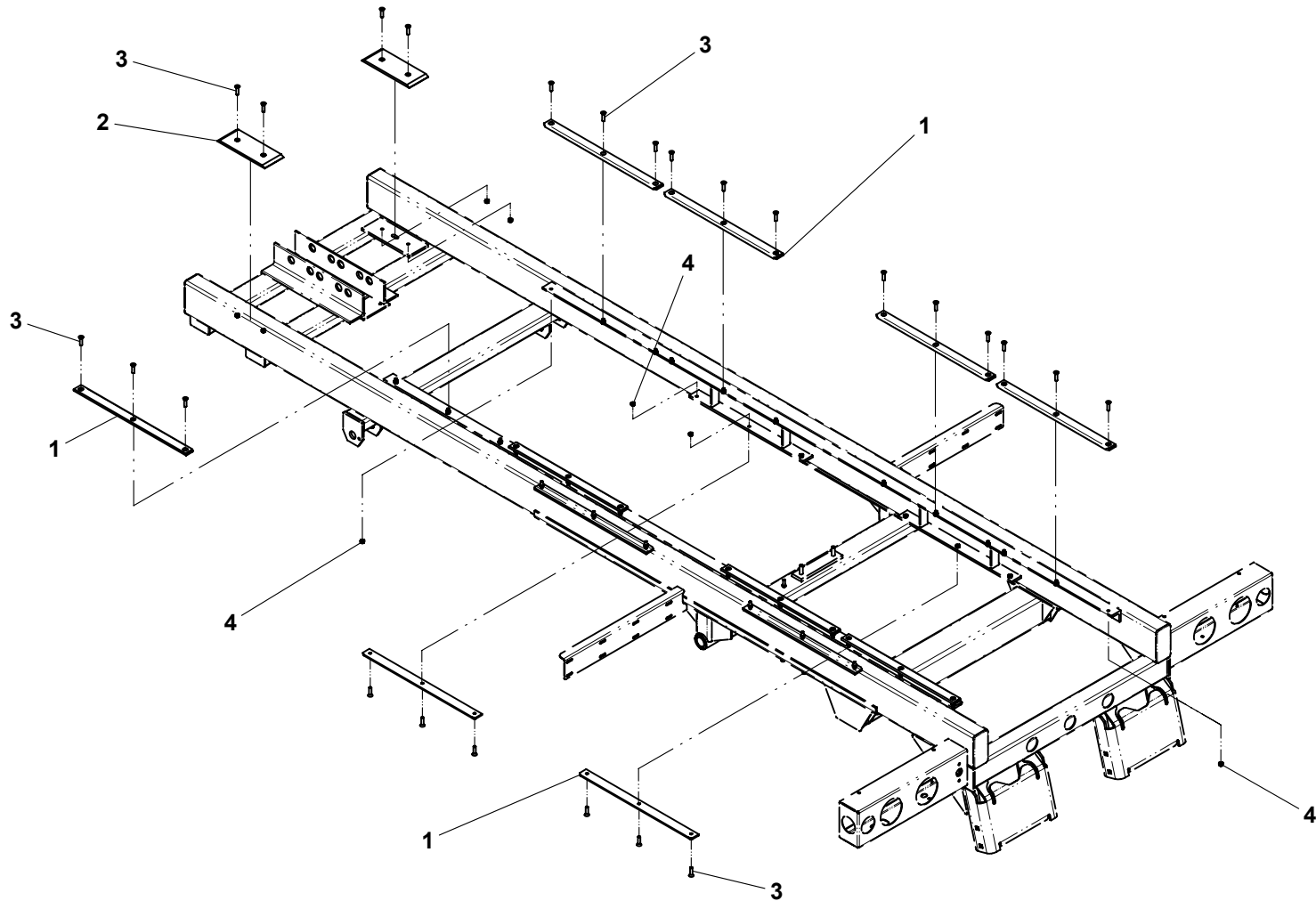

MUD FLAP

ITEM	PART NO.	DESCRIPTION	QTY
1	763800004	Mud Flap - Standard, 30" long	2
	763800013	Mud Flap - High Frame, 36" long	
2	4706000233	Plate	2
3	7111150864	Carriage Bolt, 0.31"-18NC x 1.00"	8
4	7660152601	Locknut, 0.31"-18NC	8

MUD FLAP

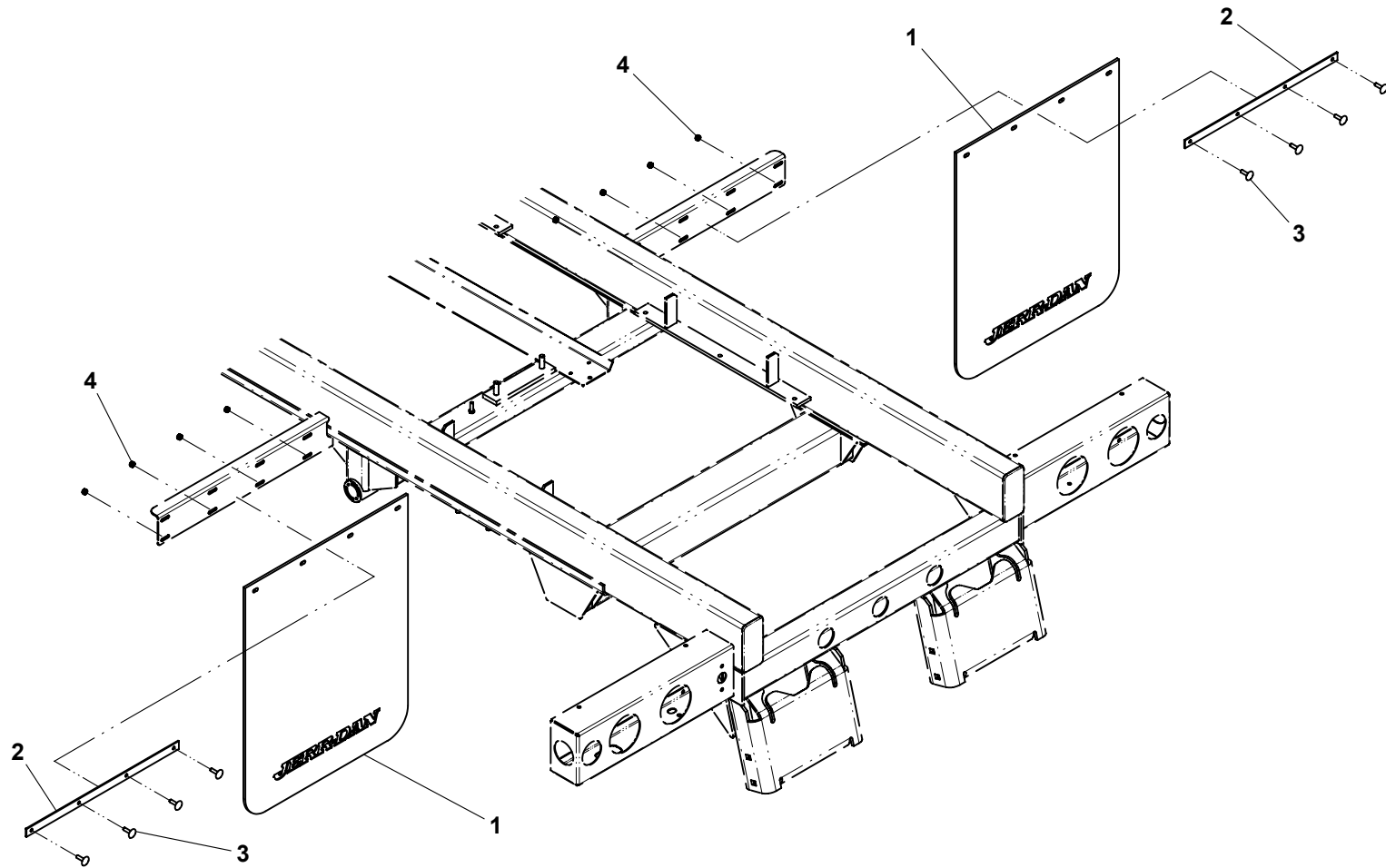

FINAL ASSEMBLY

ITEM	PART NO.	DESCRIPTION	QTY
1	3190000037	Bumper Tube Weld - Short	2
	3190000034	Bumper Tube Weld - Long	
2	7115181064	Carriage Bolt, 0.50"-13NC x 1.25"	8
3	7660182601	Locknut, 0.50"-13NC	8
4	4314000043	Light Box Cover	2
5	7661000042	U-Nut, 0.25"-20NC	8
6	7949000023	Nylon Washer, 0.26" ID	10
7	7114140529	Screw, 0.25"-20NC x 0.63"	8
8	7493000002	Grommet	4
9	7590000248	Back-Up Light - White (Std)	2
10	7590000247	Stop/Tail/Turn Light - Red (Std)	2
	7590000241	Stop/Tail/Turn Light - Red (LED)	
11	7493000009	Grommet	4
12	7590000245	Marker Light - Red (Std)	4
	7590000238	Marker Light - Red (LED)	
13	7493000023	Grommet	3
14	7590000246	Marker Light - Red (Std)	3
	7590000240	Marker Light - Red (LED)	
15	7493000010	Grommet	1
16	7590000251	License Plate Light	1
17	7011000007	Back-Up Alarm	1
18	7114140528	Screw, 0.25"-20NC x 0.63"	2
19	7660142601	Locknut, 0.25-20NC	2
20	7701000049	Plug	1
21	7701000055	Plug	2
22	7330000497	Reflector - Red	8
23	7330000428	Reflective Tape	2
24	4314000086	Cover Plate	2
25	7790161253	Screw, 0.38"-16NC x 0.75"	8
26	7679000020	Non-Skid Pad	2

FINAL ASSEMBLY

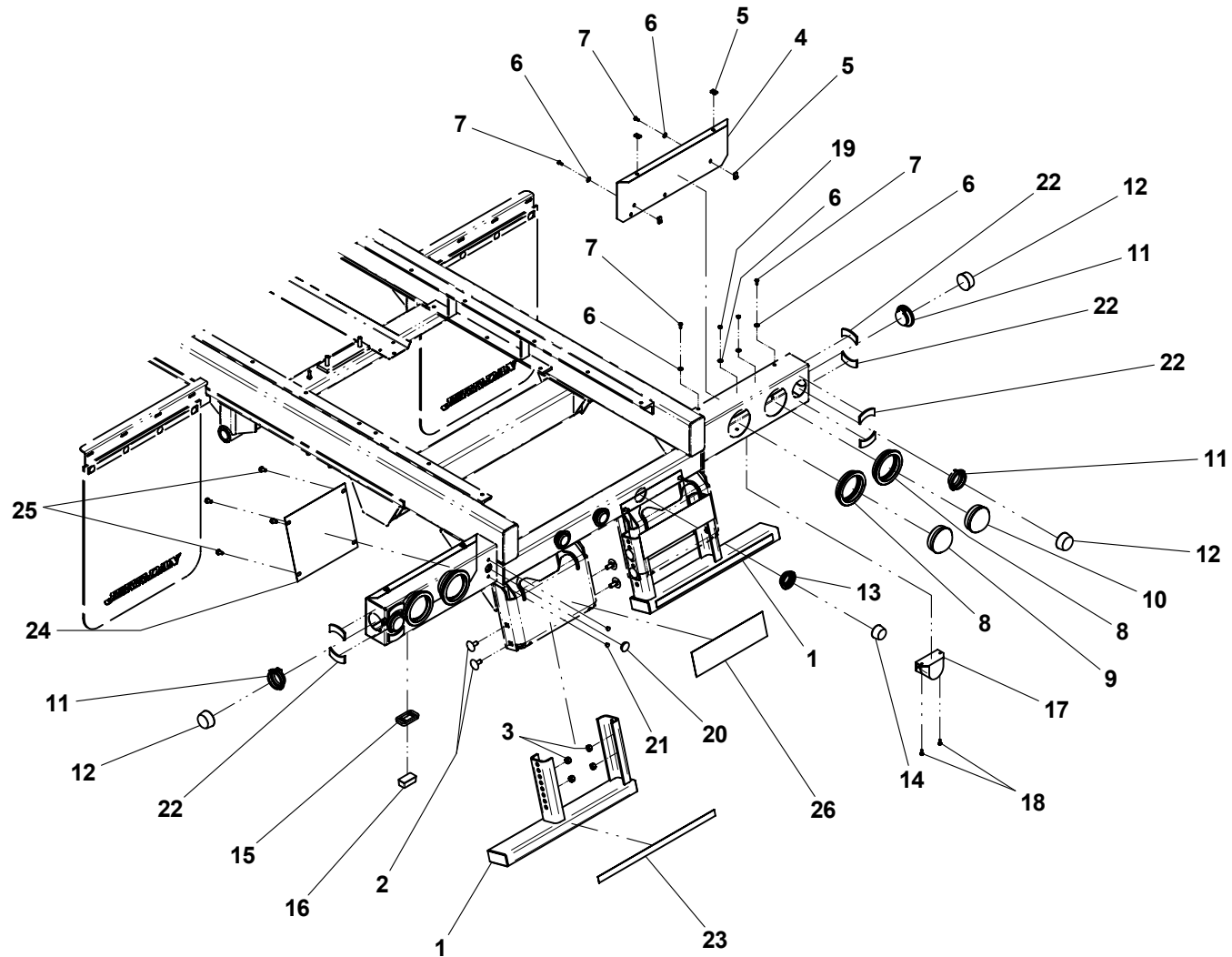

FORD F550 FRAME REINFORCEMENT AND SPRING SPACERS

ITEM	PART NO.	DESCRIPTION	QTY
1	3177000053	Brace Weld - LH	1
2	3177000054	Brace Weld - RH	1
3	7105201250	Capscrew, 0.63"-18NF x 1.75"	2
4	7660202347	Locknut, 0.63"-18NF	2
5	7105171450	Capscrew, 0.44"-20NF x 1.75"	19
6	7105171050	Capscrew, 0.44"-20NF x 1.25"	23
7	7950170142	Flatwasher, 0.44" ID	42
8	7660172331	Locknut, 0.44"-20NF	26
9	7813000048	Spacer	2
10	7120000044	U-Bolt	4

FORD F550 FRAME REINFORCEMENT AND SPRING SPACERS

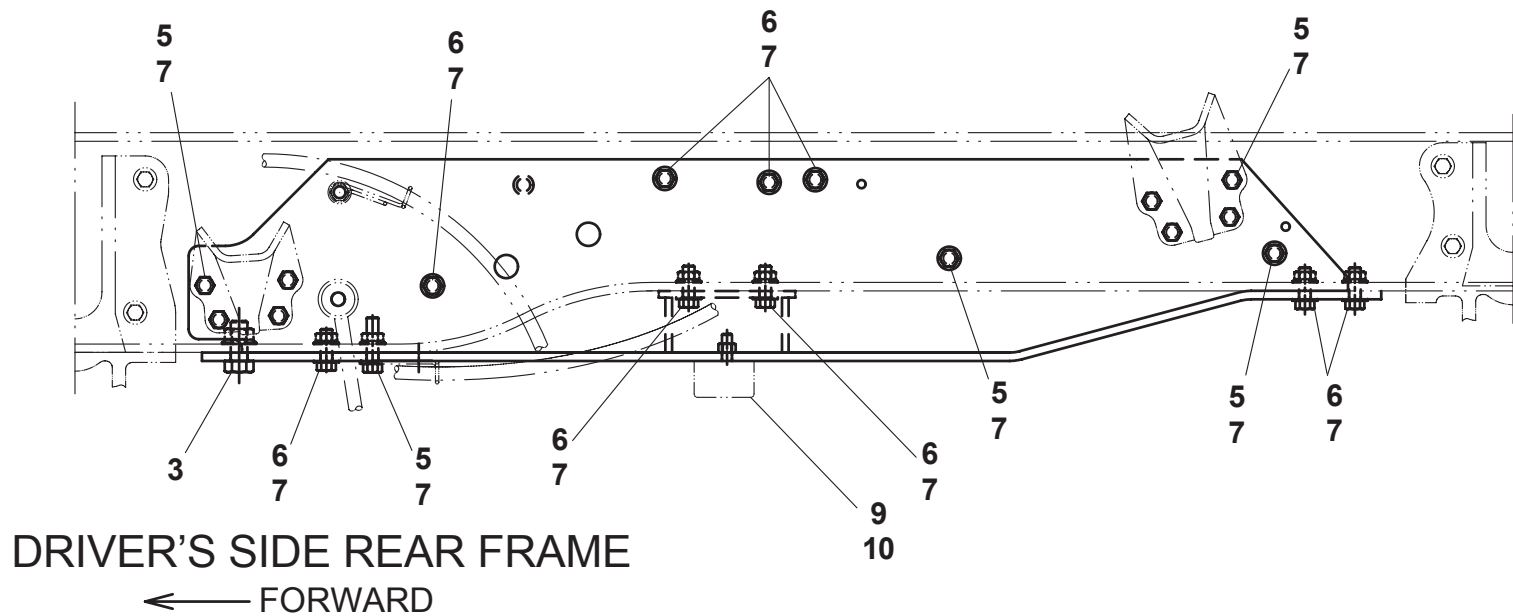
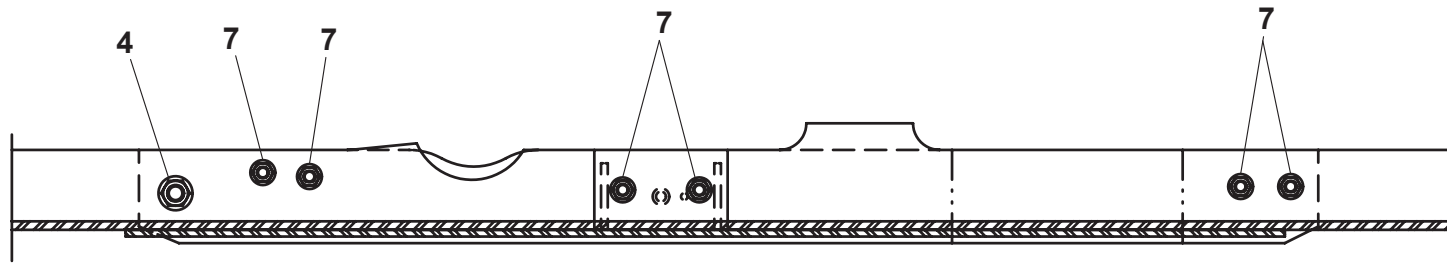

FORD F550 SUBFRAME MODIFICATIONS

ITEM	PART NO.	DESCRIPTION	QTY
1	4062000281	Bar	1
2	4178000283	Bracket	1
3	7570000016	Fuel Filler Hose	1
4	7570000017	Fuel Vent Hose	1
5	7790161253	Screw, 0.38"-16NC x 0.75"	2
6	7277000001	Clevis	1
7	4809000003	Sheave	1
8	7690151601	Clevis Pin	1
9	7690021610	Cotter Pin	1
10	7105150820	Capscrew, 0.31-24NF x 1.00"	1
11	7950150161	Flatwasher, 0.31" ID	3
12	4178000287	Bracket	1
13	7115151050	Capscrew, 0.31"-18NC x1.25"	2
14	7660152601	Locknut, 0.31"-18NC	2
15	4597000003	Plastic Loom	1
16	5526000553	Tie Strap	2
17	7701000051	Plug	2

FORD F550 SUBFRAME MODIFICATIONS

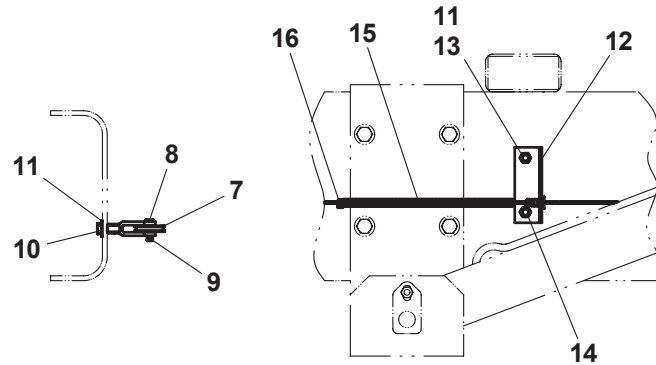

DRIVER'S SIDE

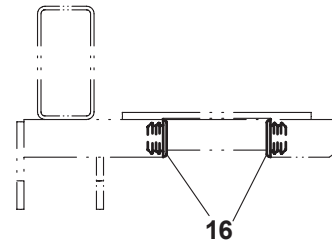

REAR SUBFRAME
CROSSMEMBER

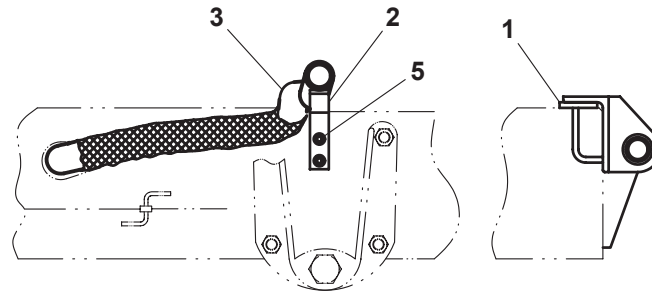

DRIVER'S SIDE

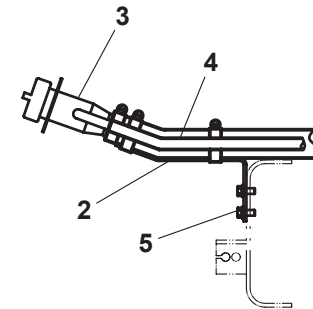

GM C4500/5500 SUBFRAME MODIFICATIONS

ITEM	PART NO.	DESCRIPTION	QTY
1	4178000421	Bracket	1
2	7570000023	Fuel Filler Hose (2005 & earlier)	1
	7570000031	Fuel Filler Hose (2006 & later)	
3	7912000233	Fuel Fillneck (2006 & later diesel)	1
	7912000235	Fuel Fillneck (2006 & later gas)	
4	7570000017	Fuel Vent Hose (2006 & later diesel)	1
5	7254000021	Fill Cap - 2006 & later gas only	1
6	7115182150	Capscrew, 0.50"-13NC x 1.50"	2
7	7660182301	Locknut, 0.50"-13NC	2
8	4705000607	Plate	2
9	7701000051	Plug	2

GM C4500/5500 SUBFRAME MODIFICATIONS

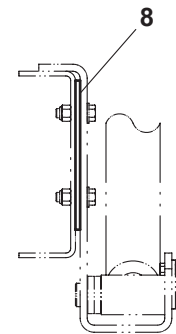
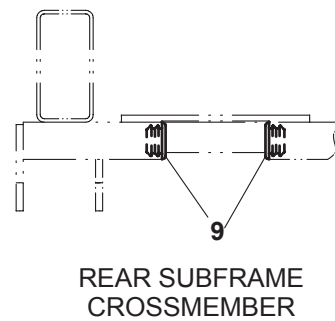
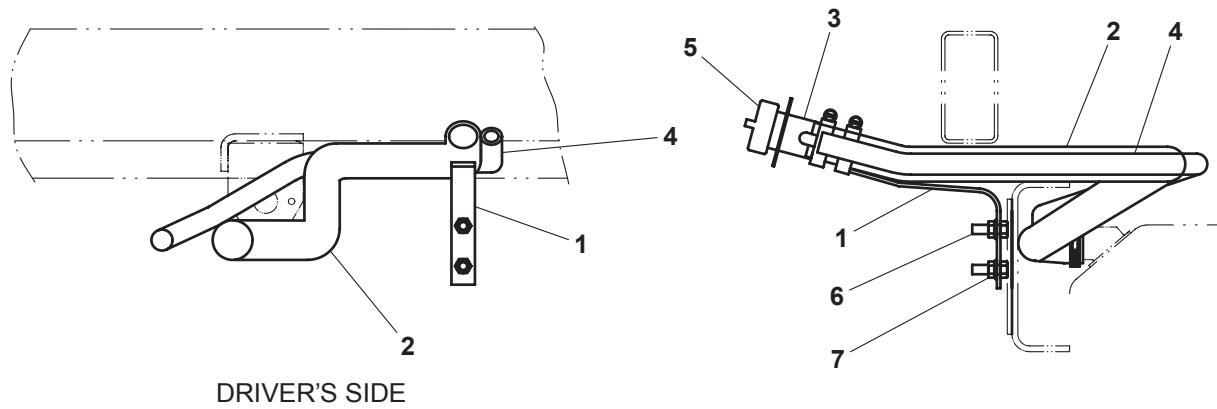

GM C4500/5500 BRAKE CABLE REWORK AND REAR FUEL TANK MODIFICATIONS

ITEM	PART NO.	DESCRIPTION	QTY
1	4178000421	Bracket	1
2	7570000025	Fuel Filler Hose (2005 & earlier)	1
3	7912000234	Fuel Fillneck (2006 & later diesel)	1
	7912000236	Fuel Fillneck (2006 & later gas)	
4	7105181450	Capscrew, 0.50-20NF x 1.75"	2
5	7950180153	Flatwasher, 0.50" ID	2
6	7660182631	Locknut, 0.50"-20NF	2
7	4178000474	Bracket	1
8	4178000475	Bracket (2006 & earlier)	1
	4178000682	Bracket (2007 & later)	
9	7493000011	Grommet	2

GM C4500/5500 BRAKE CABLE REWORK AND REAR FUEL TANK

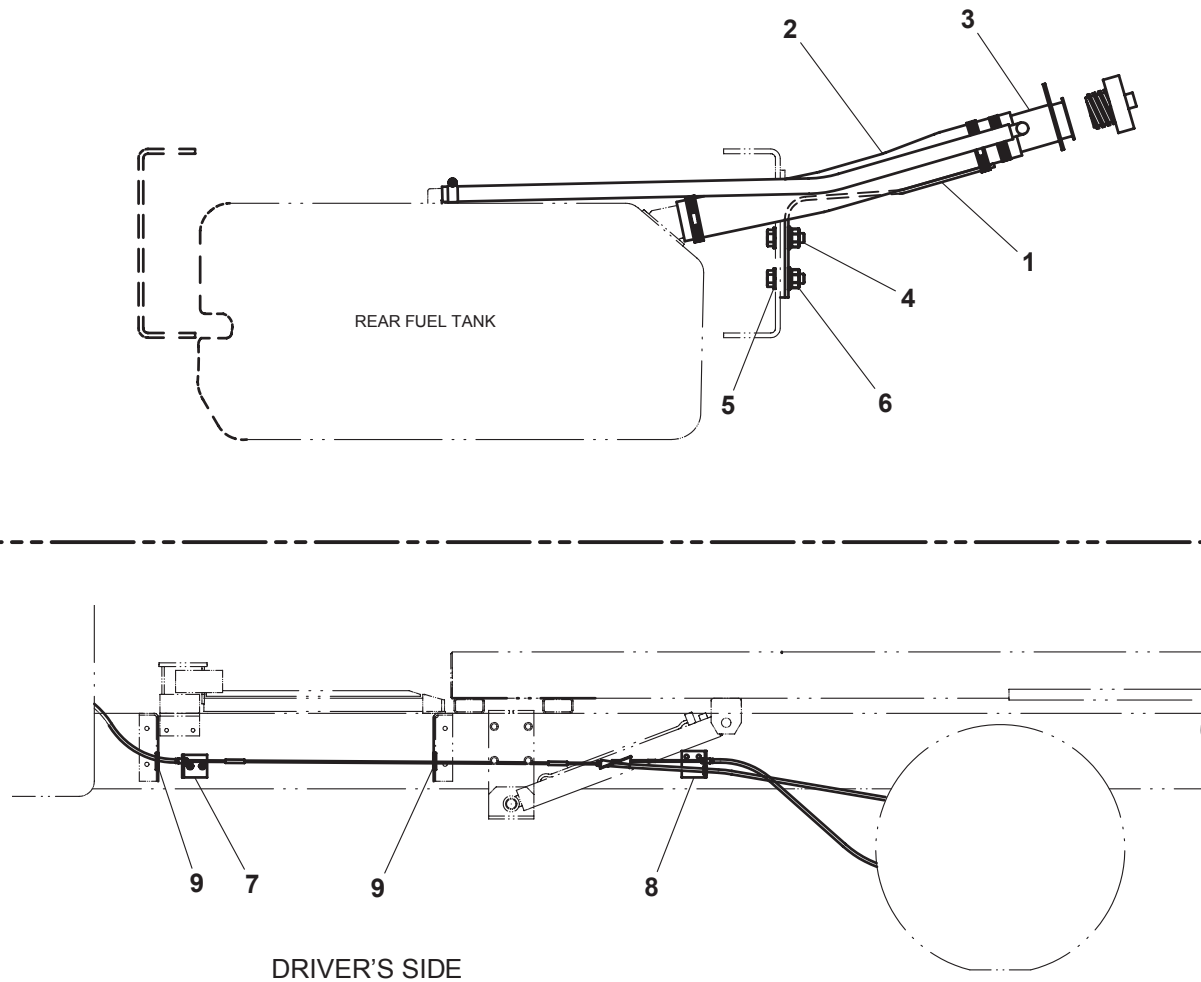

HYDRAULIC RESERVOIR AND TOOLBOX / BASKET

ITEM	PART NO.	DESCRIPTION	QTY*
1	4178000331	Mounting Bracket - Short	
	4178000291	Mounting Bracket - Std	
	4178000339	Mounting Bracket - Long	
2	4178000330	Mounting Bracket - Short	
	4178000290	Mounting Bracket - Std	
	4178000338	Mounting Bracket - Long	
3	3750000018	Hydraulic Reservoir Assembly	
4	7183000004+	Breather Filler Cap Assembly	
5	7470000009+	Level / Temperature Gauge	
6	7430000014+	Strainer	
7	7105181450	Capscrew, 0.50"-20NF x 1.75"	
8	7950180153	Flat Washer, 0.50" ID	
9	7660182631	Locknut, 0.50"-20NF	
10	7115150850	Capscrew, 0.31"-18NC x 1.00"	
11	7950150161	Flatwasher, 0.31" ID	
12	7660152601	Locknut, 0.31"-18NC	
13	3899000130	Toolbox Assembly - 36" x 18" x 18"	
	3899000131	Toolbox Assembly - 36" x 18" x 14"	
	3899000132	Toolbox Assembly - 48" x 18" x 18"	
	3899000133	Toolbox Assembly - 60" x 18" x 18"	
14	4679000256^	Rubber Pad (36" Toolbox)	
	4679000257^	Rubber Pad (48" Toolbox)	
	4679000258^	Rubber Pad (60" Toolbox)	
15	7118181216	Capscrew, 0.50"-13NC x 1.50"	
16	7660182301	Locknut, 0.50"-13NC	
17	4706002361	Plate	
18	4017000777	High Mount Angle	
19	3899000053	Basket - 15" deep	
	3899000075	Basket - 24" deep	
20	4632000015	Moulding - 15" deep basket	
	4632000048	Moulding - 24" deep basket	
21	7002000410	Stainless Steel Cover Plate for Basket includes rivets	

+ also available in Hydraulic Reservoir Assembly, P/N 3750000018

^ included in Toolbox Assembly

* Quantities vary depending on Hydraulic Tank / Toolbox / Basket mounting configuration.

HYDRAULIC RESERVOIR AND TOOLBOX / BASKET

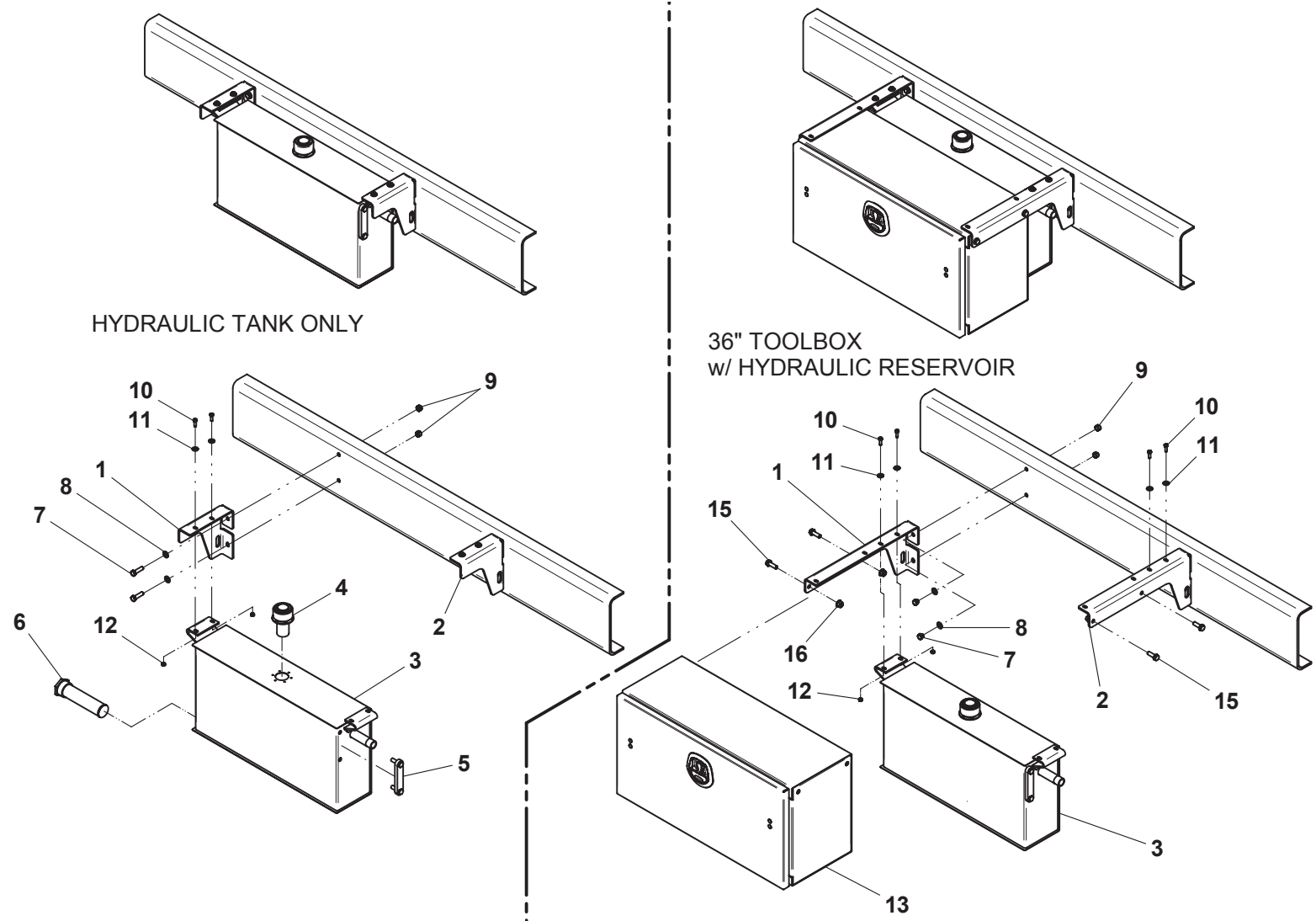

Item #14, Toolbox Rubber Pad, not shown

HYDRAULIC RESERVOIR AND TOOLBOX / BASKET

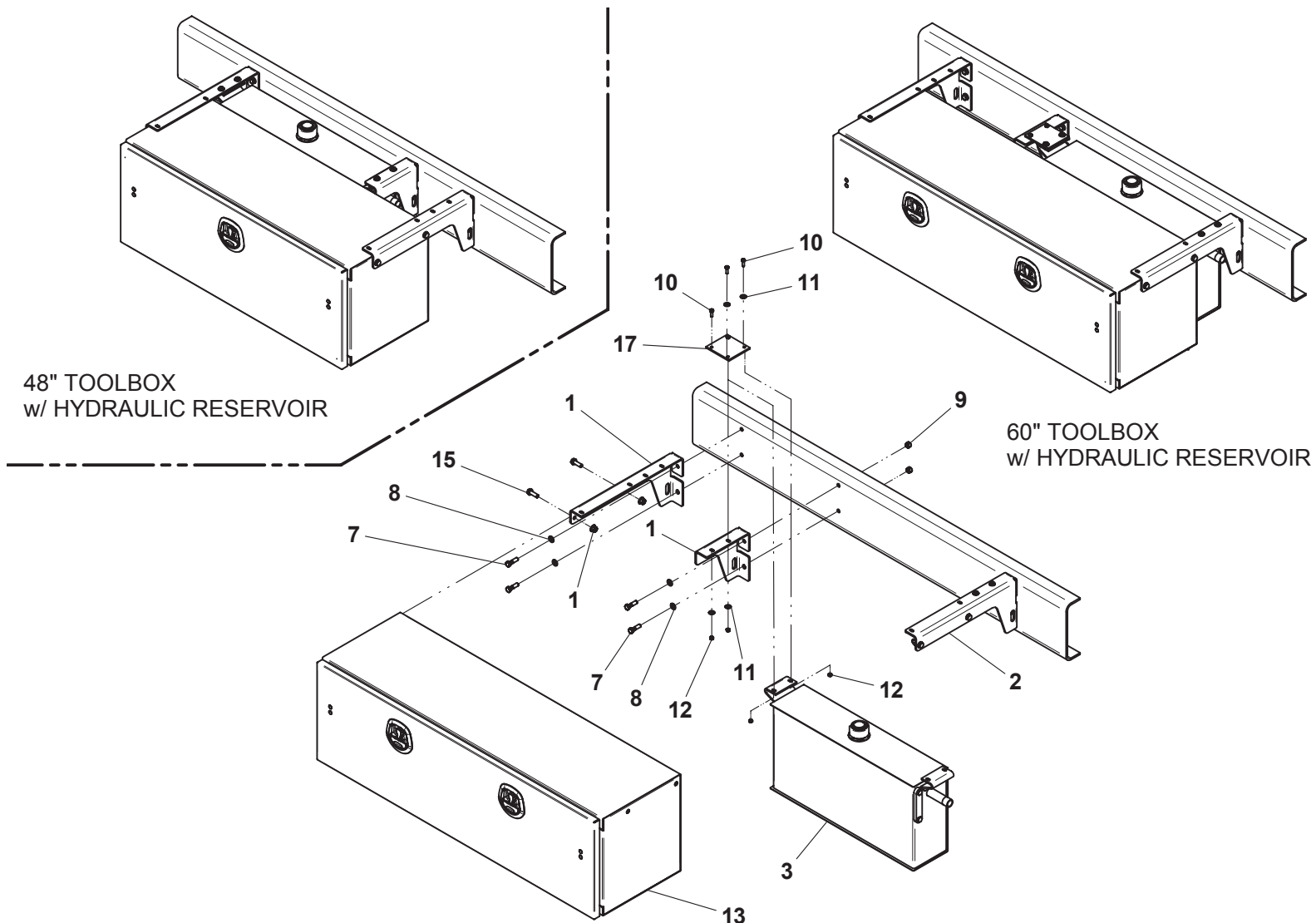

48" TOOLBOX
w/ HYDRAULIC RESERVOIR

60" TOOLBOX
w/ HYDRAULIC RESERVOIR

Item #14, Toolbox Rubber Pad, not shown

HYDRAULIC RESERVOIR AND TOOLBOX / BASKET

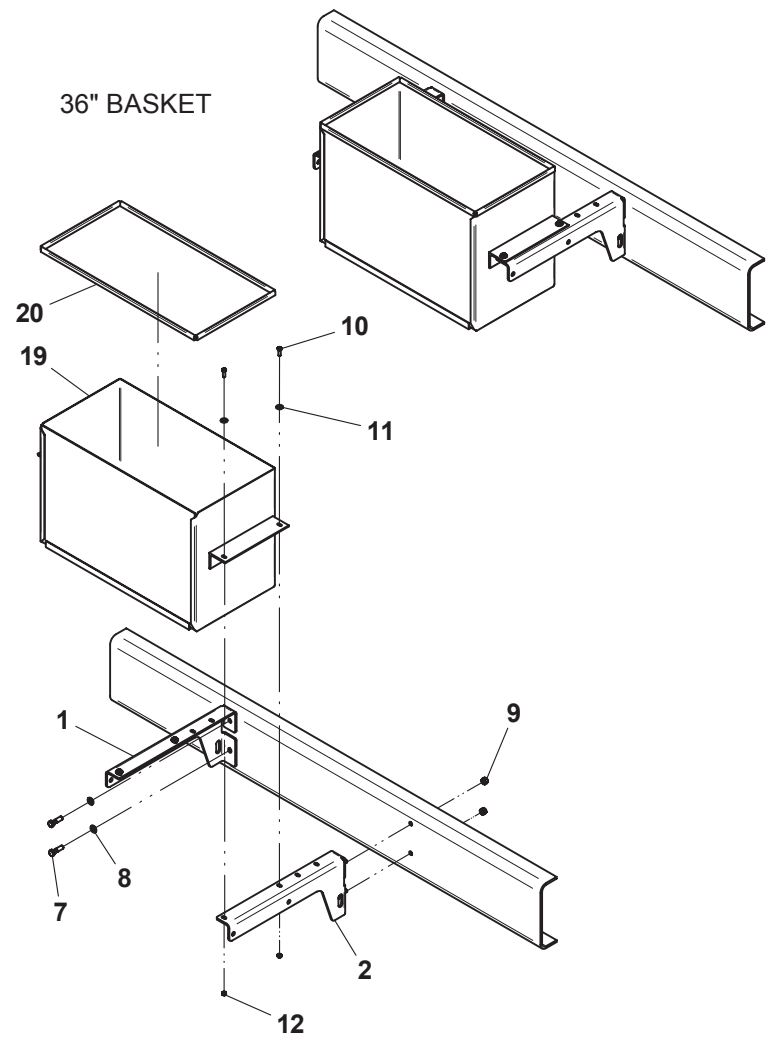
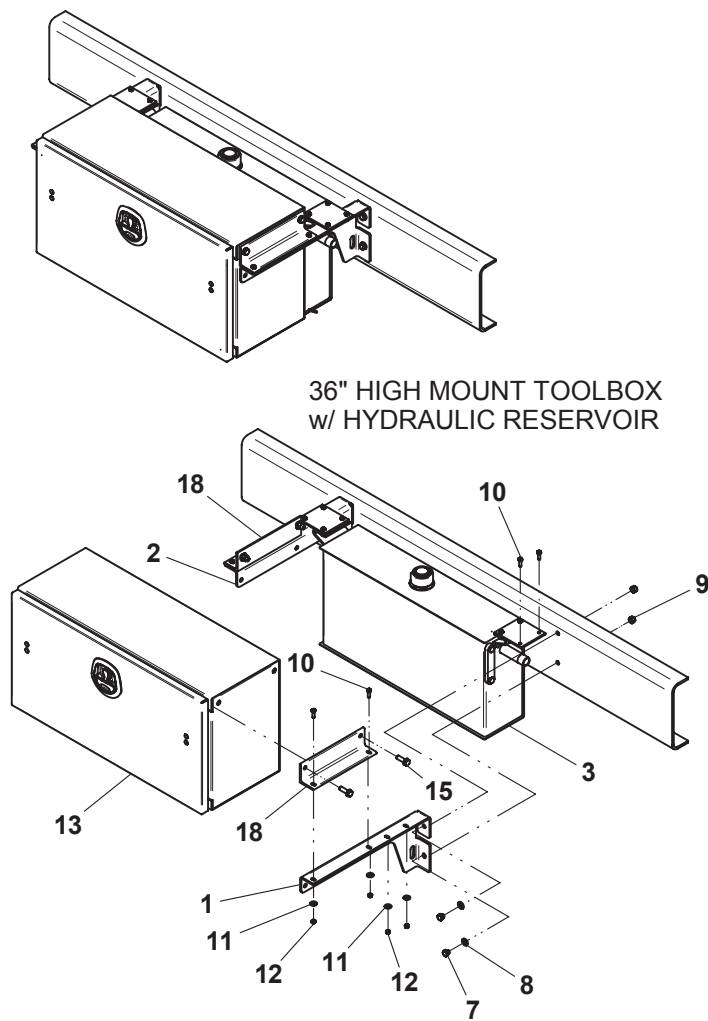

Items #14, Toolbox Rubber Pad and #21, Stainless Cover for Basket, not shown

TOOLBOX

ITEM	PART NO.	DESCRIPTION	QTY*
1	4679000256	Rubber Pad (36" toolbox)	1
	4679000257	Rubber Pad (36" narrow toolbox)	1
	4679000258	Rubber Pad (48" toolbox)	1
	4679000259	Rubber Pad (60" toolbox)	1
2	4796000009	Gasket (36" toolbox)	1
	4796000010	Gasket (48" toolbox)	1
	4796000011	Gasket (60" toolbox)	1
3	9899000014	Toolbox Door Assembly (36" toolbox)	1
	9899000015	Toolbox Door Assembly (48" toolbox)	1
	9899000016	Toolbox Door Assembly (60" toolbox)	1
4	7585000019^	Latch	1
5	7555000016^	Hinge (36" toolbox)	1
	7555000015^	Hinge (48" toolbox)	2
	7555000016^	Hinge (60" toolbox)	2
6	7759000020^	Rivet (36" toolbox)	9
	7759000020^	Rivet (48" toolbox)	14
	7759000020^	Rivet (60" toolbox)	18
7	4178000599^	Bracket	2
8	7114140465^	Carriage Bolt, 0.25"-20NC x 0.50"	4
9	7660142604^	Locknut, 0.25"-20NC	4
10	7592000005^	S Link	4
11	7248000114^	Cable	2

* Quantities listed are for one toolbox

^ also included in Toolbox Door Assembly

TOOLBOX

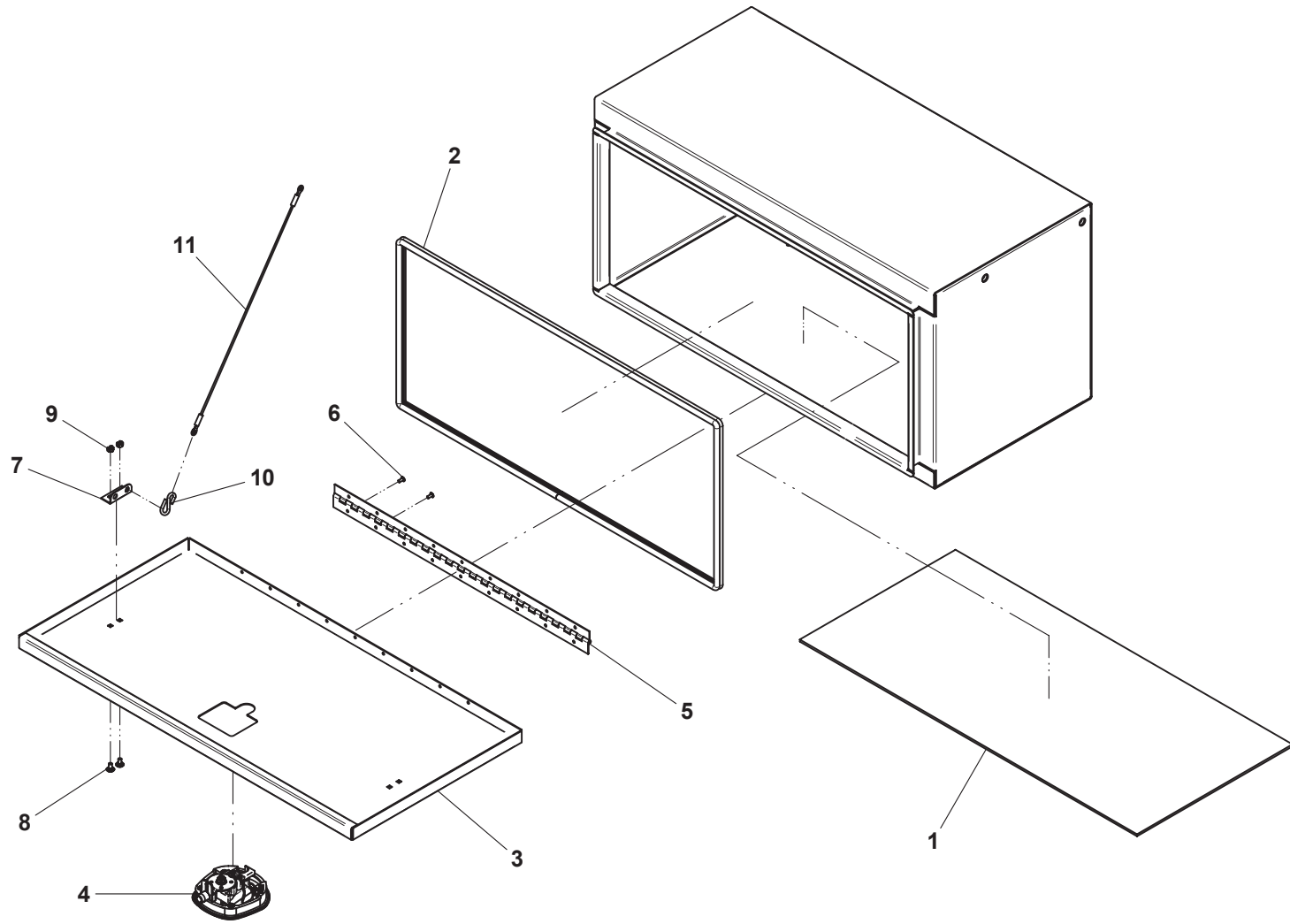

36" Toolbox shown

TOOLBOX SHELF

ITEM	PART NO.	DESCRIPTION	QTY
1	4017001403	Angle	2
2	4811000841	Shelf (36" toolbox)	1
	4811000843	Shelf (48" toolbox)	
	4811000868	Shelf (60" toolbox)	
3	7115150850	Capscrew, 0.31"-18NC x 1.00"	4
4	7950150161	Flatwasher, 0.31" ID	8
5	7660152601	Locknut, 0.31"-18NC	4

TOOLBOX SHELF

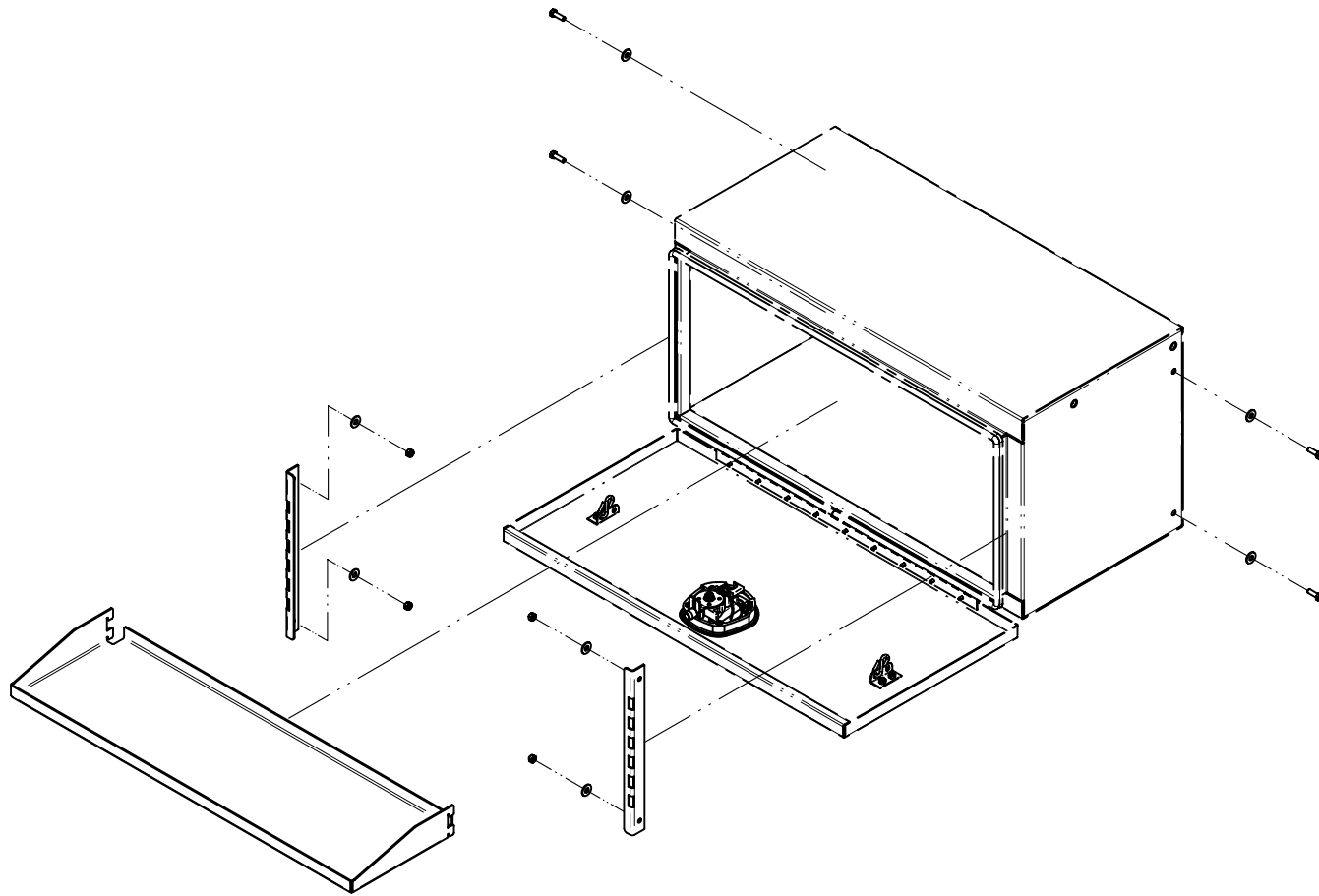

36" Toolbox shown

TOOLBOX LIGHT

ITEM	PART NO.	DESCRIPTION	QTY
1	4178000578*	Bracket	1
2	7590000273*	Dome Lamp	1
3	7870000115*	Switch	1
4	7280000007*	Wire Mount Clip	3
5	7661000047*	Panel Nut	4
6	7790100856*	Screw, #10 x 0.50"	4
7	7443000377	Fitting	1
8	7552000297	Toolbox Light Harness	1

* included in Toolbox Light Bracket Assembly

TOOLBOX LIGHT

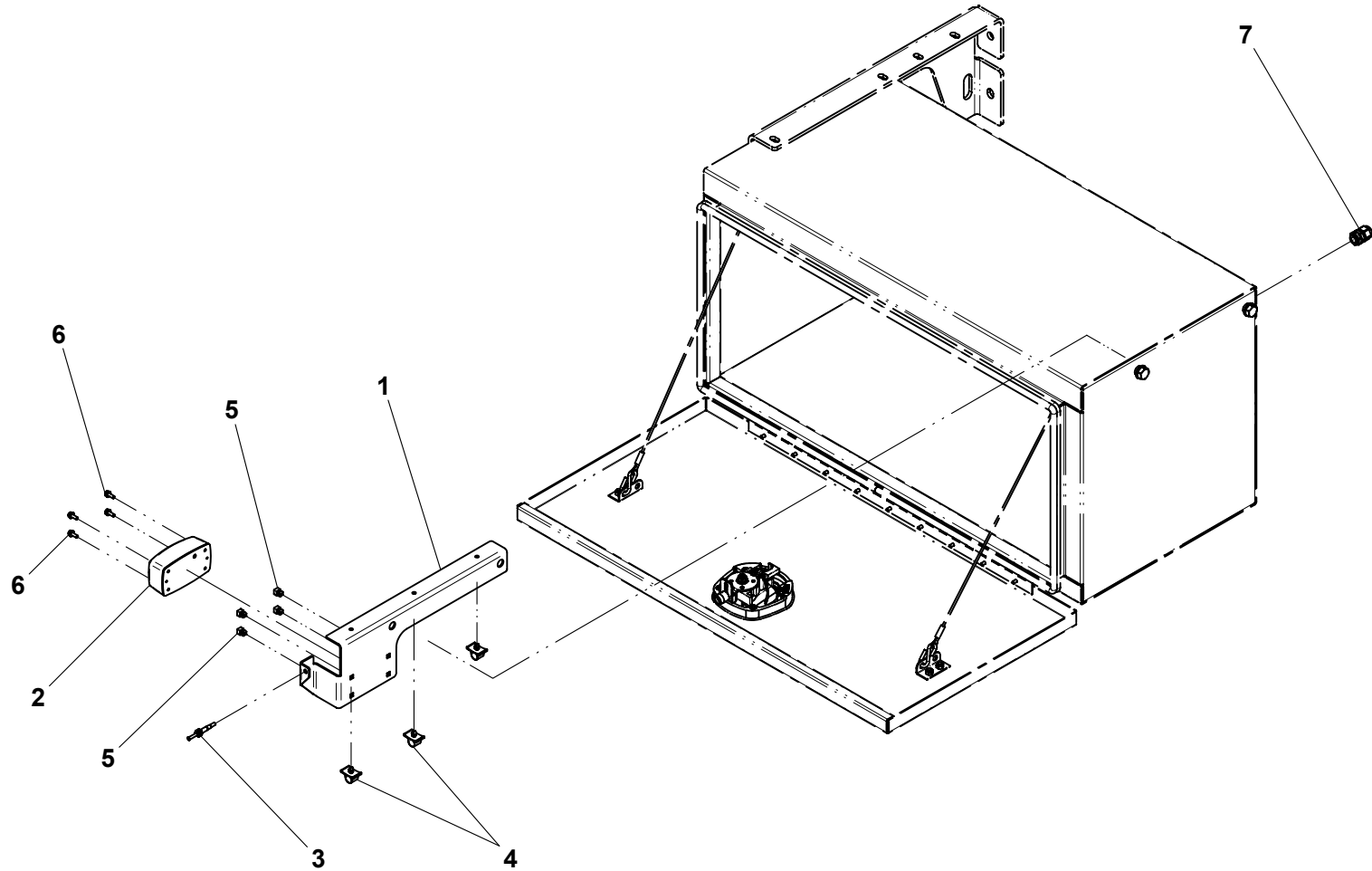

Item #8, Toolbox Light Harness, not shown
48" Toolbox Shown

DUAL CONTROLS - 3 BANK

ITEM	PART NO.	DESCRIPTION	QTY	ITEM	PART NO.	DESCRIPTION	QTY
1	4263000431	Channel	1	29	7949000054	Washer, 0.34" ID	8
2	7950180161	Flatwasher, 0.50" ID	4	30	7330000456	Control Panel, LH	1
3	7660182601	Locknut, 0.50"-13NC	4	31	7330000457	Control Panel, RH	1
4	4263000430	Channel	1	32	7759000006	Pop Rivet	8
5	7790151253	Screw, 0.31"-18NC x 0.75"	12	33	7590000087	Lamp	2
6	3935000111	Control Valve	1	34	7791060872	Screw, #6 x 0.50"	4
	3935000115	Control Valve (foreign chassis)		35	7280000007	Wire Clip	11
7	7111161050	Capscrew, 0.38"-16NC x 1.25"	4	36	4606000217	Lug	2
8	7950160161	Flatwasher, 0.38" ID	4				
9	7660162601	Locknut, 0.38"-16NC	4				
10	4763000280	Control Rod	3				
11	4763000279	Control Rod	3				
12	7690101200	Clevis Pin	3				
13	7691000056	Cotter Pin	3				
14	7115150850	Capscrew, 0.31"-18NC x 1.00"	9				
15	7949000011	Flatwasher, 0.31" ID	9				
16	4831000069	Spacer	9				
17	7660152601	Locknut, 0.31"-18NC	17				
18	4606000065	Lug	2				
19	7115150664	Carriage Bolt, 0.31"-18NC x 0.75"	8				
20	7950150000	Washer, 0.31" ID	8				
21	7691000064	Pin	2				
22	7754000009	Retaining Ring	4				
23	7551000018	Control Handle	2				
24	7551000020	Control Handle	2				
25	7551000021	Control Handle	2				
26	4211000001	Bushing	4				
27	7950220141	Flatwasher, 0.75" ID	4				
28	7560000003	Control Hood	2				

DUAL CONTROLS - 3 BANK

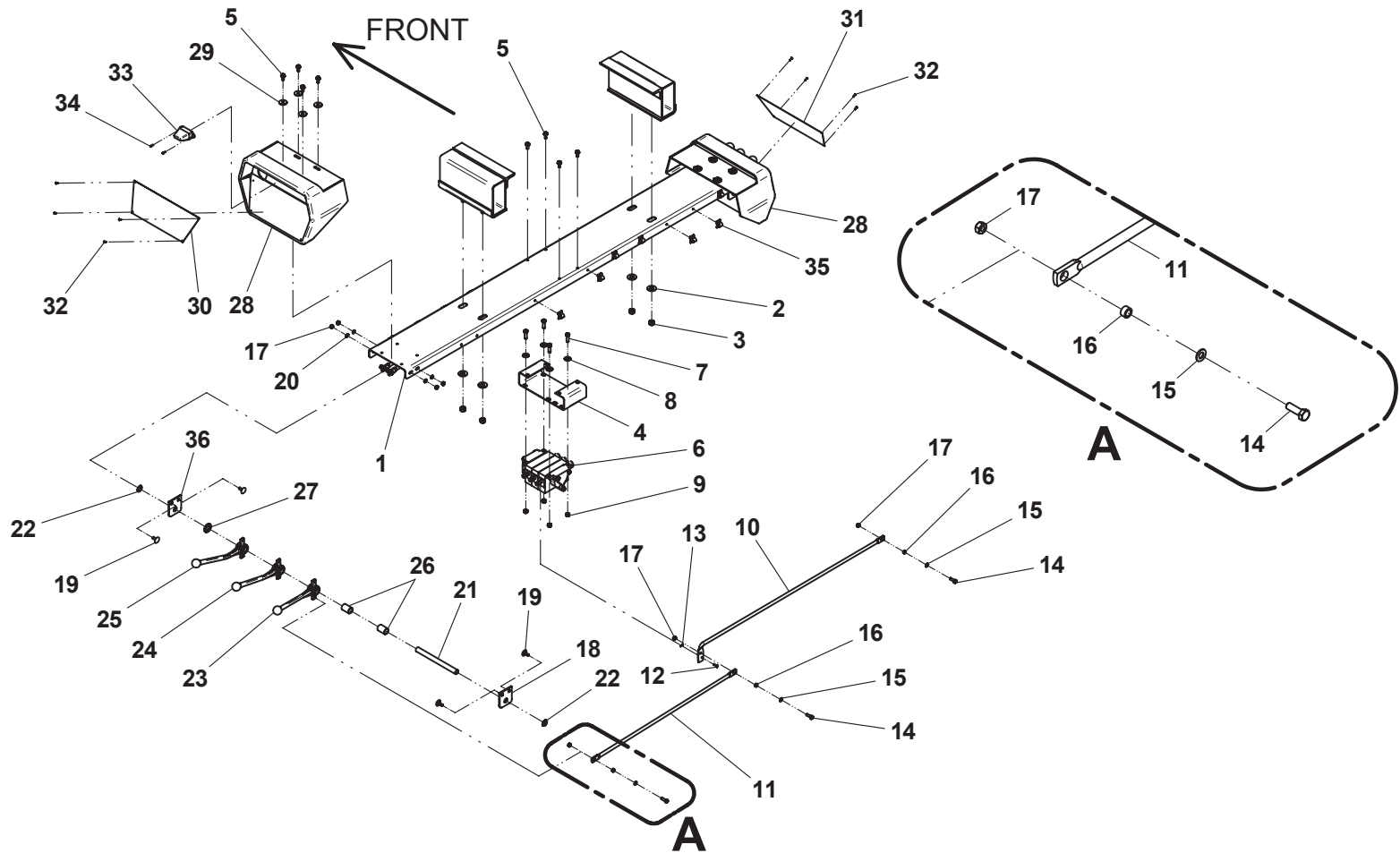

DUAL CONTROLS - 4 BANK

ITEM	PART NO.	DESCRIPTION	QTY	ITEM	PART NO.	DESCRIPTION	QTY
1	4263000431	Channel	1	30	7330000458	Control Panel, LH (stabilizer)	1
2	7950180161	Flatwasher, 0.50" ID	4		7330000456	Control Panel, LH (hydraulic tow option)	
3	7660182601	Locknut, 0.50"-13NC	4	31	7330000459	Control Panel, RH (stabilizer)	1
4	4263000430	Channel	1		7330000457	Control Panel, RH (hydraulic tow option)	
5	7790151253	Screw, 0.31"-18NC x 0.75"	12	32	7759000006	Pop Rivet	8
6	3935000112	Control Valve	1	33	7590000087	Lamp	2
	3935000116	Control Valve (foreign chassis)		34	7791060872	Screw, #6 x 0.50"	4
7	7111161050	Capscrew, 0.38"-16NC x 1.25"	4	35	7280000007	Wire Clip	11
8	7950160161	Flatwasher, 0.38" ID	4	36	4606000217	Lug	2
9	7660162601	Locknut, 0.38"-16NC	4				
10	4763000280	Control Rod	4				
11	4763000279	Control Rod	4				
12	7690101200	Clevis Pin	4				
13	7691000056	Cotter Pin	4				
14	7115150850	Capscrew, 0.31"-18NC x 1.00"	12				
15	7949000011	Flatwasher, 0.31" ID	12				
16	4831000069	Spacer	12				
17	7660152601	Locknut, 0.31"-18NC	20				
18	4606000065	Lug	2				
19	7115150664	Carriage Bolt, 0.31"-18NC x 0.75"	8				
20	7950150000	Washer, 0.31" ID	8				
21	7691000064	Pin	2				
22	7754000009	Retaining Ring	4				
23	7551000018	Control Handle	2				
24	7551000020	Control Handle	4				
25	7551000021	Control Handle	2				
26	4211000001	Bushing	2				
27	7950220141	Flatwasher, 0.75" ID	2				
28	7560000003	Control Hood	2				
29	7949000054	Washer, 0.34" ID	8				

DUAL CONTROLS - 4 BANK

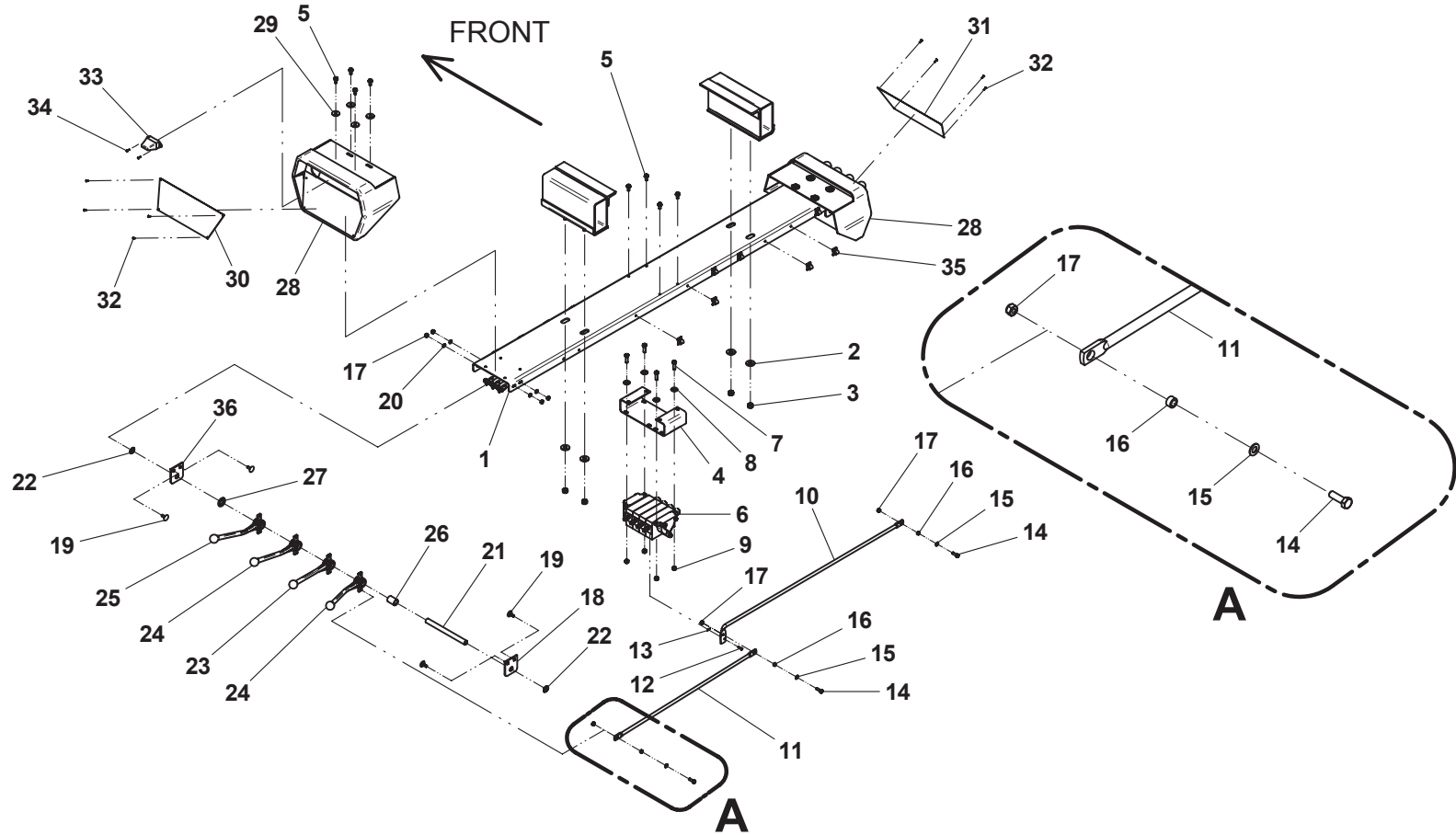

DUAL CONTROLS - 5 BANK

ITEM	PART NO.	DESCRIPTION	QTY	ITEM	PART NO.	DESCRIPTION	QTY
1	4263000431	Channel	1	29	7330000458	Control Panel, LH (stabilizer)	1
2	7950180161	Flatwasher, 0.50" ID	4		7330000456	Control Panel, LH (IRL)	
3	7660182601	Locknut, 0.50"-13NC	4	30	7330000459	Control Panel, RH (stabilizer)	1
4	4263000430	Channel	1		7330000457	Control Panel, RH (IRL)	
	4263000433	Channel (remote winch)		31	7759000006	Pop Rivet	8
5	7790151253	Screw, 0.31"-18NC x 0.75"	12	32	7590000087	Lamp	2
6	3935000113	Control Valve	1	33	7791060872	Screw, #6 x 0.50"	4
	3935000117	Control Valve (foreign chassis)		34	7280000007	Wire Clip	11
7	7111161050	Capscrew, 0.38"-16NC x 1.25"	4	35	4606000217	Lug	2
8	7950160161	Flatwasher, 0.38" ID	4				
9	7660162601	Locknut, 0.38"-16NC	4				
10	4763000280	Control Rod	5				
11	4763000279	Control Rod	5				
12	7690101200	Clevis Pin	5				
13	7691000056	Cotter Pin	5				
14	7115150850	Capscrew, 0.31"-18NC x 1.00"	15				
15	7949000011	Flatwasher, 0.31" ID	15				
16	4831000069	Spacer	15				
17	7660152601	Locknut, 0.31"-18NC	23				
18	4606000065	Lug	2				
19	7115150664	Carriage Bolt, 0.31"-18NC x 0.75"	8				
20	7950150000	Washer, 0.31" ID	8				
21	7691000064	Pin	2				
22	7754000009	Retaining Ring	4				
23	7551000018	Control Handle	2				
24	7551000020	Control Handle	4				
25	7551000021	Control Handle	4				
26	7950220141	Flatwasher, 0.75" ID	2				
27	7560000003	Control Hood	2				
28	7949000054	Washer, 0.34" ID	8				

DUAL CONTROLS - 5 BANK

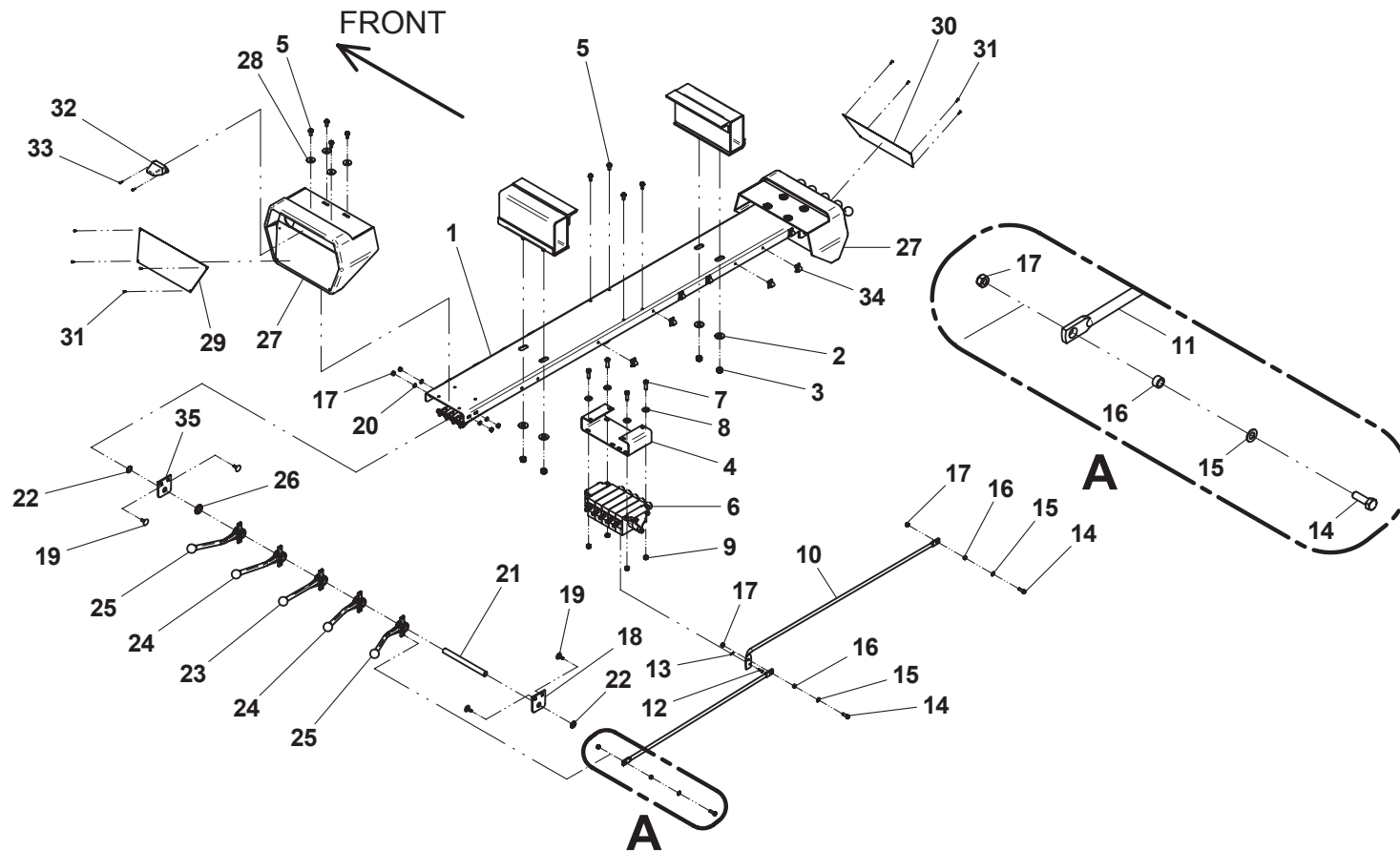

DUAL CONTROLS - 6 BANK

ITEM	PART NO.	DESCRIPTION	QTY	ITEM	PART NO.	DESCRIPTION	QTY
1	4263000431	Channel (manual grids)	1	29	7330000462	Control Panel, LH (manual grids)	1
	4263000434	Channel (hydraulic grids)			7330000588	Control Panel, LH (hydraulic grids)	
2	7950180161	Flatwasher, 0.50 ID	4	30	7330000463	Control Panel, RH (manual grids)	1
3	7660182601	Locknut, 0.50-13NC	4		7330000589	Control Panel, RH (hydraulic grids)	
4	4263000433	Channel	1	31	7759000006	Pop Rivet	8
5	7790151253	Screw, 0.31-18NC x 0.75	12	32	7590000087	Lamp	2
6	3935000114	Control Valve (manual grids)	1	33	7791060872	Screw, #6 x 0.50"	4
	3935000166	Control Valve (hydraulic grids)		34	7280000007	Wire Clip	11
	3935000118	Control Valve (manual grids & foreign chassis)		35	4606000217	Lug	2
7	7111161050	Capscrew, 0.38-16NC x 1.25"	4				
8	7950160161	Flatwasher, 0.38" ID	4				
9	7660162601	Locknut, 0.38"-16NC	4				
10	4763000280	Control Rod	6				
11	4763000279	Control Rod	6				
12	7690101200	Clevis Pin	6				
13	7691000056	Cotter Pin	6				
14	7115150850	Capscrew, 0.31"-18NC x 1.00"	18				
15	7949000011	Flatwasher, 0.31" ID	18				
16	4831000069	Spacer	18				
17	7660152601	Locknut, 0.31"-18NC	26				
18	4606000065	Lug	2				
19	7115150664	Carriage Bolt, 0.31"-18NC x 0.75"	8				
20	7950150000	Washer, 0.31" ID	8				
21	7691000065	Pin	2				
22	7754000009	Retaining Ring	4				
23	7551000019	Control Handle	4				
24	7551000020	Control Handle	4				
25	7551000021	Control Handle	4				
26	7950220141	Flatwasher, 0.75" ID	2				
27	7560000003	Control Hood	2				
28	7949000054	Washer, 0.34" ID	8				

DUAL CONTROLS - 6 BANK

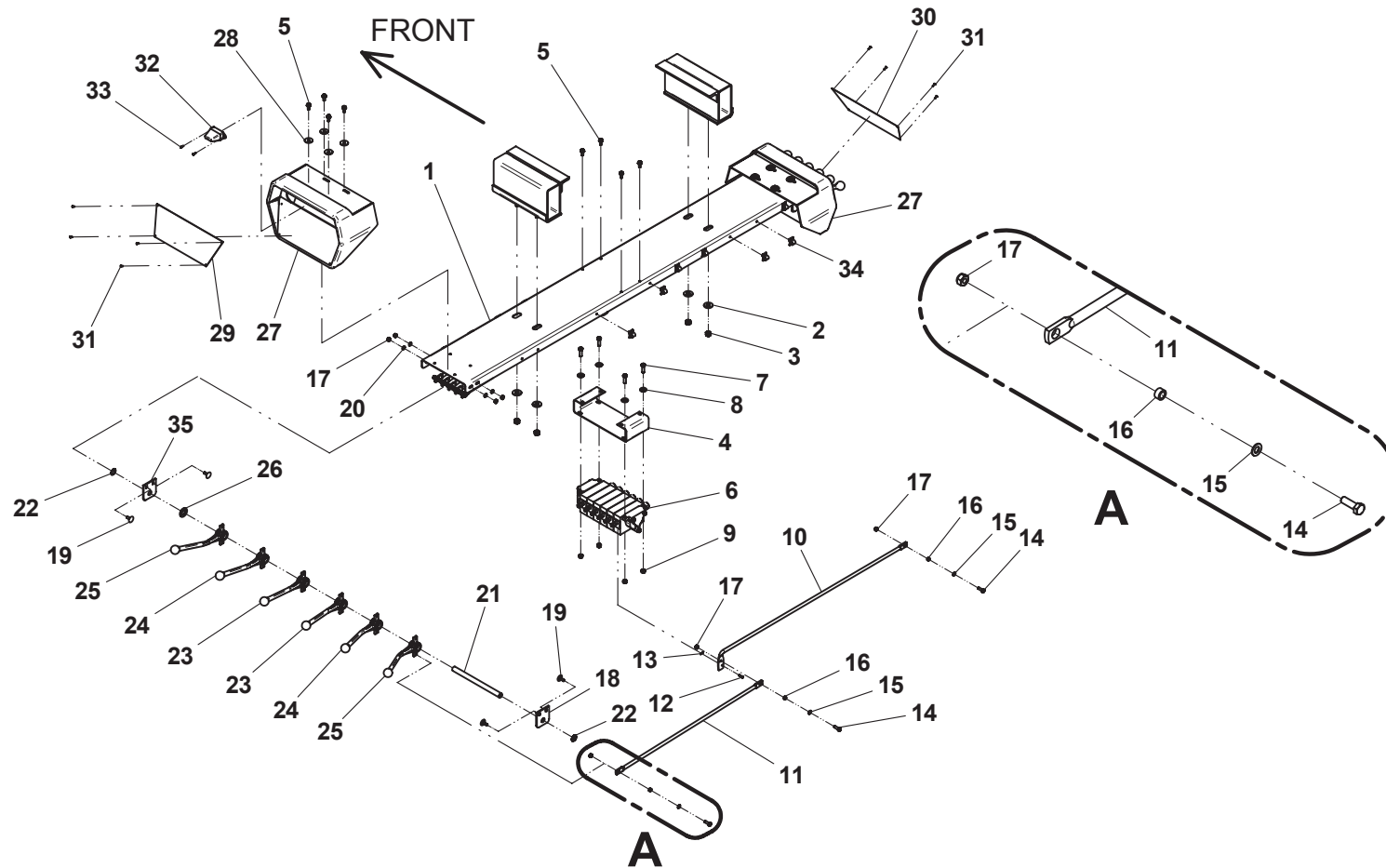

DUAL CONTROLS - 7 BANK

ITEM	PART NO.	DESCRIPTION	QTY	ITEM	PART NO.	DESCRIPTION	QTY
1	4263000463	Channel	1	31	7330000548	Control Panel, LH	1
2	7950180161	Flatwasher, 0.50 ID	6	32	7330000549	Control Panel, RH	1
3	7660182601	Locknut, 0.50-13NC	6	33	7759000004	Pop Rivet	8
4	4263000464	Channel	1	34	7590000087	Lamp	2
5	7790151253	Screw, 0.31-18NC x 0.75	12	35	7790101276	Screw, #6 x 0.50"	4
6	3935000150	Control Valve	1	36	7280000007	Wire Clip	11
7	7111161050	Capscrew, 0.38-16NC x 1.25"	4	37	4606000217	Lug	2
8	7950160161	Flatwasher, 0.38" ID	4				
9	7660162601	Locknut, 0.38"-16NC	4				
10	4763000280	Control Rod	7				
11	4763000279	Control Rod	7				
12	7690101200	Clevis Pin	7				
13	7691000056	Cotter Pin	7				
14	7115150850	Capscrew, 0.31"-18NC x 1.00"	21				
15	7949000011	Flatwasher, 0.31" ID	21				
16	4831000069	Spacer	21				
17	7660152601	Locknut, 0.31"-18NC	29				
18	4606000065	Lug	2				
19	7115150664	Carriage Bolt, 0.31"-18NC x 0.75"	8				
20	7950150000	Washer, 0.31" ID	8				
21	7691000065	Pin	2				
22	7754000009	Retaining Ring	4				
23	7551000019	Control Handle	4				
24	7551000020	Control Handle	4				
25	7551000021	Control Handle	4				
26	7551000022	Control Handle	2				
27	7950220141	Flatwasher, 0.75" ID	2				
28	4211000001	Bushing	2				
29	3560000009	Control Hood	2				
30	4632000029	Moulding	2				

DUAL CONTROLS - 7 BANK

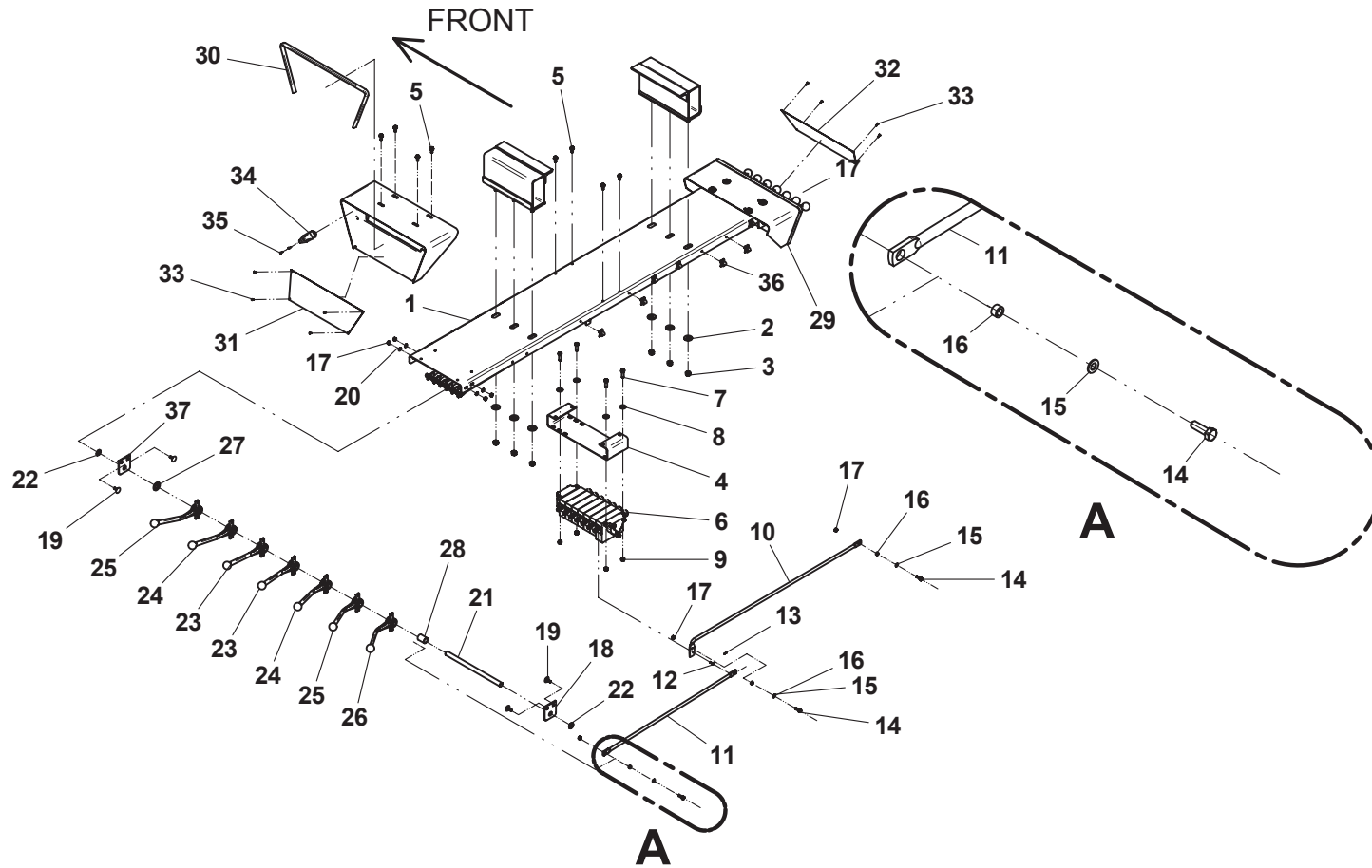

HYDRAULIC COMPONENTS - STANDARD

ITEM	PART NO.	DESCRIPTION	QTY	ITEM	PART NO.	DESCRIPTION	QTY
1	See Note 1	PTO	1	30	4569433111*	Hose Assembly	1
2	7724000021	Pump	1		4569433122	Hose Assembly (156" CA)	
3	7115181050	Capscrew	2	31	4569432111*	Hose Assembly	1
4	7950180000	Lockwasher	2		4569432122	Hose Assembly (156" CA)	
5	7443000101	Adapter	1	32	4567430118	Hose Assembly (19' deck)	2
6	7445081643	Adapter	1		4567430133	Hose Assembly (20' & 21' decks)	
7	7443000023	Elbow	1	33	7431000001^	Filter Element	1
8	See Note 1	Supply Hose	1				
9	7443000013	Nipple	1				
10	7274000002	Clamp	2				
11	7430000003	Filter Assembly	1				
12	7470000002	Gauge	1				
13	7443000319	Fitting	1				
14	7274000047	Clamp	2				
15	See Note 1	Return Hose	1				
16	See Note 1	Pressure Hose Assembly	1				
17	7443000168	Adapter	1				
18	7445081045	Elbow	3				
19	7443000337	Check Valve	1				
20	7445080843	Adapter	2				
21	7445060843	Adapter	3				
22	4567123044*	Hose Assembly	1				
	4567123050	Hose Assembly (156" CA)					
23	4567122032*	Hose Assembly	1				
24	7445060645	Elbow	5				
25	7445060643	Adapter	3				
26	4567122115*	Hose Assembly	1				
27	4567123115*	Hose Assembly	1				
28	7935000306	Dual Counterbalance Valve	1				
29	4570000195*	Hose Assembly (Out Board Tilt Cylinders)	4				
	4270000198*	Hose Assembly (In Board Tilt Cylinders)					

* included in Hose Kit, P/N 4577000004 for Out Board Tilt Cylinders
& P/N 4577000005 for In Board Tilt Cylinders

^ also available in Filter Assembly, P/N 7430000003

Note 1: Varies depending on chassis, transmission , PTO type & deck length.
Consult factory for part numbers.

HYDRAULIC COMPONENTS - STANDARD

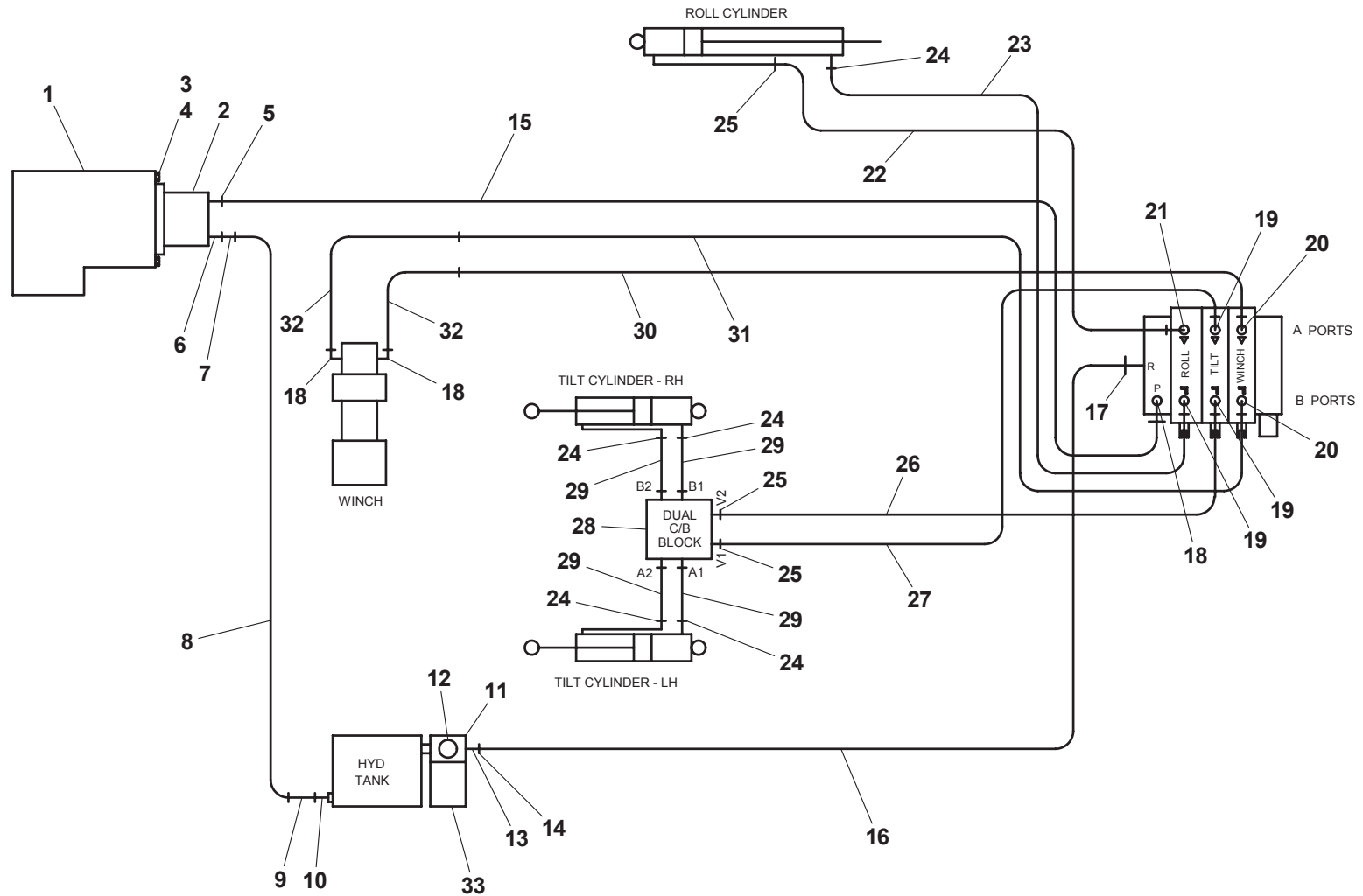

HYDRAULIC COMPONENTS - STANDARD (HOSE TRACK)

ITEM	PART NO.	DESCRIPTION	QTY
1	7904000002	Hose Track	1
2	4706003038	Plate	1
3	7114101618	Capscrew	4
4	7660102604	Locknut, #10-24NC	4
5	7274000038	Clamp	4
6	7274000039	Clamp Cover	2
7	7115151650	Capscrew, 0.31"-18NC x 2.00"	2
8	7950150161	Flatwasher, 0.31" ID	4
9	7660152601	Locknut, 0.31"-13NC (19' deck)	6
	7660152601	Locknut, 0.31"-13NC (20' & 21' decks)	7
10	7894000004	Tie Strap	10
11	7935000197	Counterbalance Valve	1
12	7115151850	Capscrew, 0.31"-18NC x 2.25"	2
13	7274000066	Double Clamp (19' deck)	4
	7274000066	Double Clamp (20' & 21' decks)	5
14	7280000013	Clip	*

* Quantity varies depending on deck length and deck type.

HYDRAULIC COMPONENTS - STANDARD (HOSE TRACK)

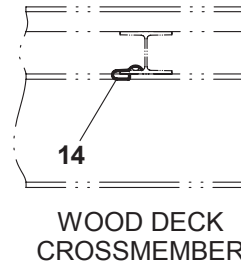
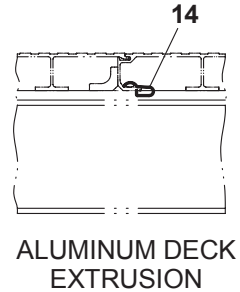
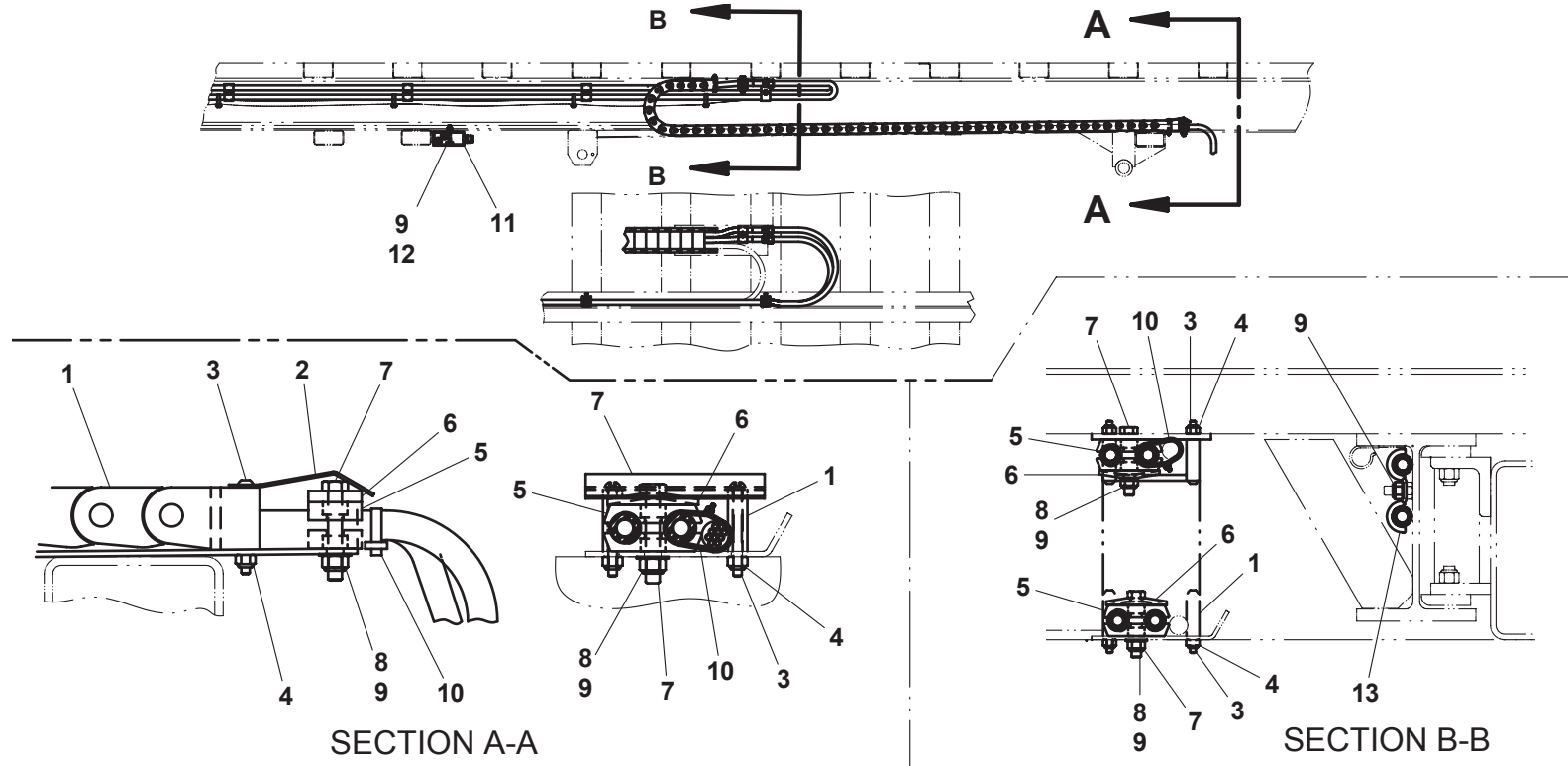

HYDRAULIC COMPONENTS - HOSE ROUTING / MOUNTING

ITEM	PART NO.	DESCRIPTION	QTY
1	7274000076	Cast Frame Clamp	*
2	7785152420	Set Screw, 0.31"-18NC x 1.50"	*
3	7660152601	Locknut, 0.31"-18NC	*
4	7115151050	Capscrew, 0.31"-18NC x 1.25"	*
5	7950150161	Flatwasher, 0.31" ID	*
6	7274000040	Clamp	*
7	7274000041	Clamp	*
8	7274000042	Clamp	*
9	4706003844	Plate	*
10	7115151064	Carriage Bolt, 0.31"-18NC x 1.25"	*

* Quantity varies depending on deck length and deck type

HYDRAULIC COMPONENTS - HOSE ROUTING / MOUNTING

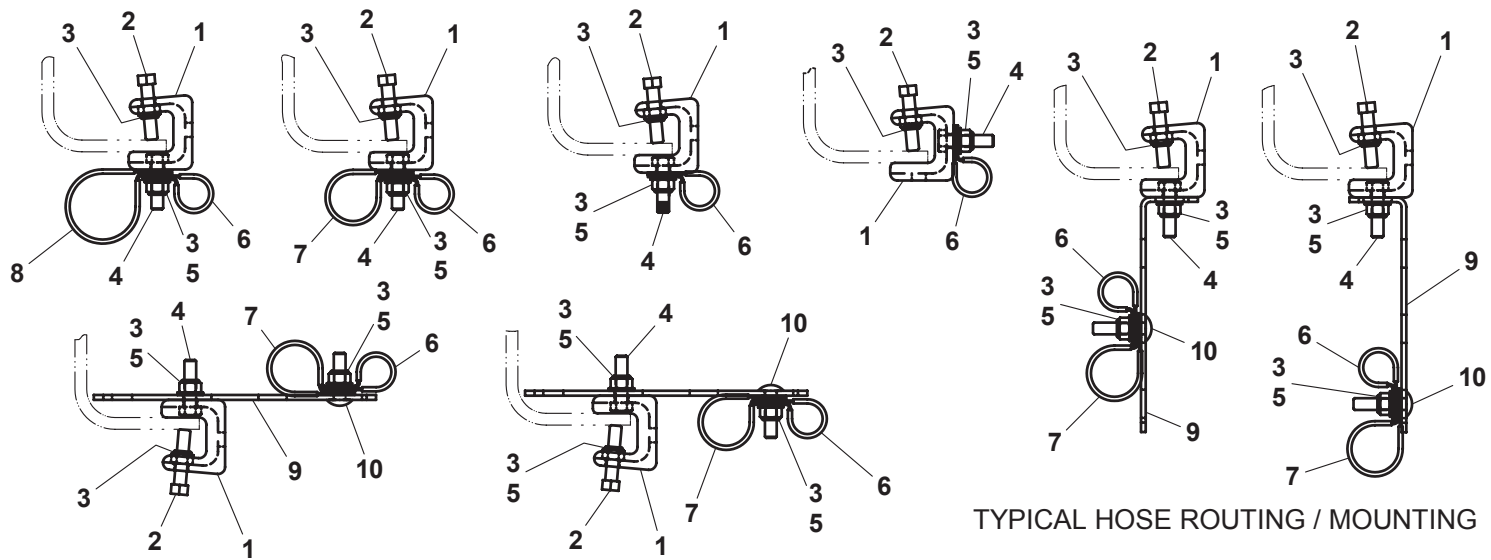
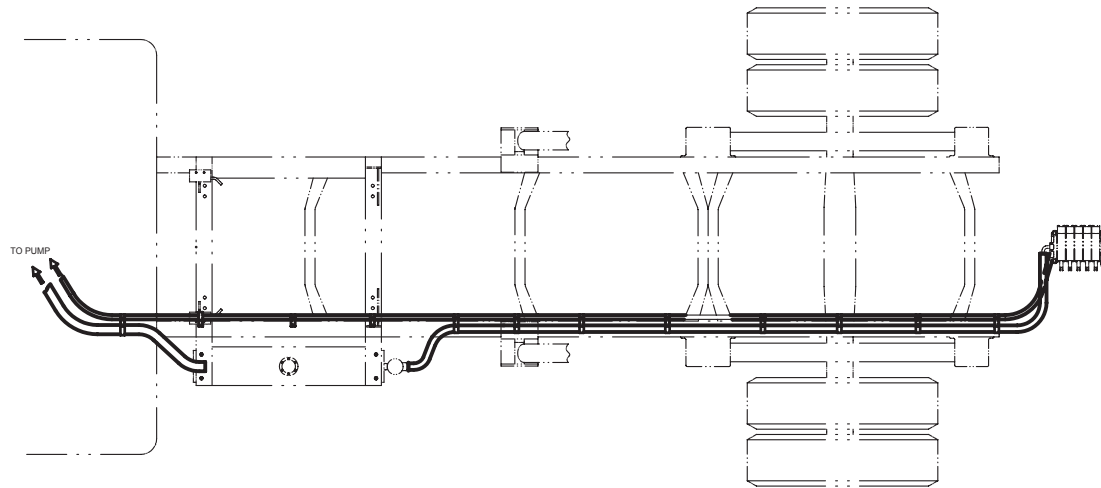

TYPICAL HOSE ROUTING / MOUNTING

HYDRAULIC COMPONENTS - IRL WHEEL LIFT WITH MANUAL GRIDS

ITEM	PART NO.	DESCRIPTION	QTY
1	7443000129	Reducer	2
2	7445060648	Tee	4
3	4567123033*	Hose Assembly	2
4	4567122030*	Hose Assembly	2
5	7935000305	Counterbalance Valve	2
6	7445060645	Elbow	4
7	4567122014*	Hose Assembly	2
8	7445040843	Adapter	2
9	4567110032*	Hose Assembly	2
10	7445040446	Elbow	2

* also available in Hose Kit, P/N 4577000002

HYDRAULIC COMPONENTS - IRL WHEEL LIFT WITH MANUAL GRIDS

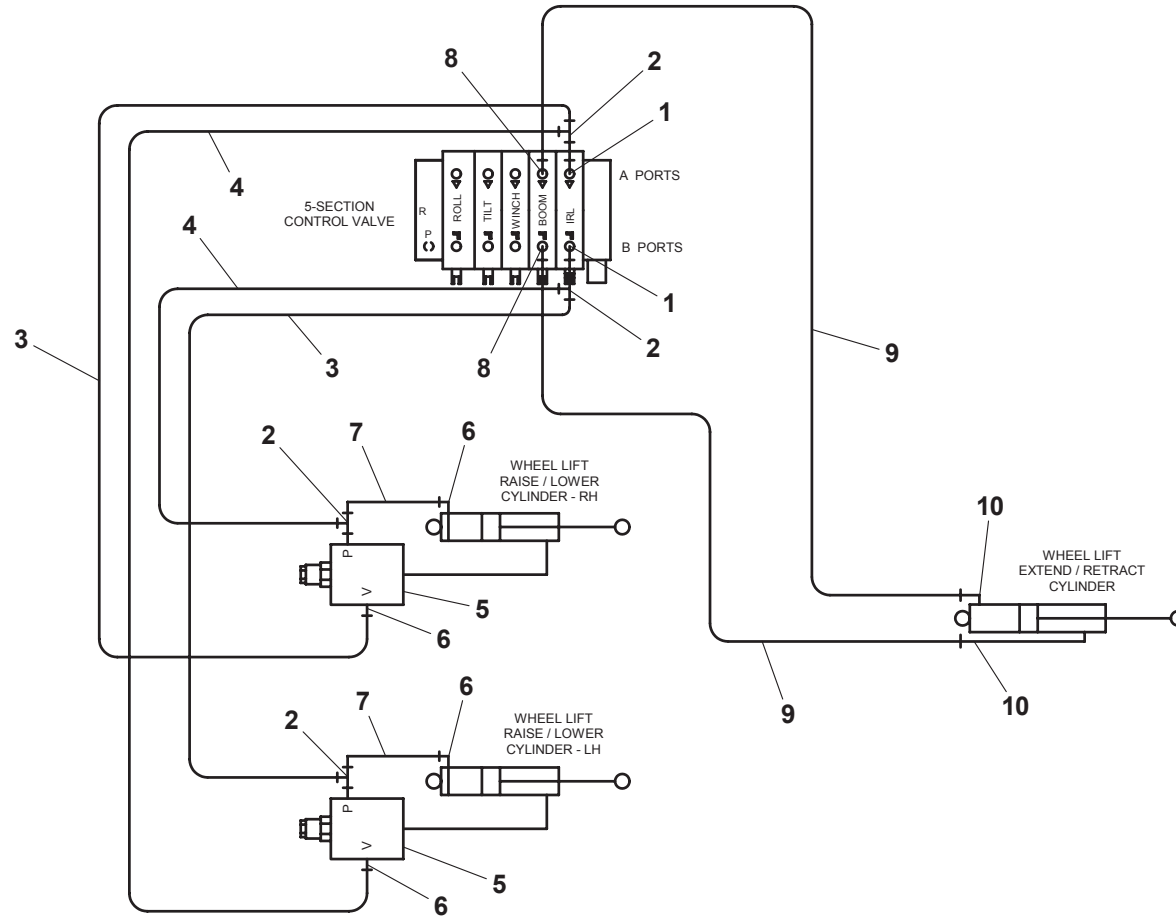

HYDRAULIC COMPONENTS - IRL WHEEL LIFT WITH HYDRAULIC GRIDS

ITEM	PART NO.	DESCRIPTION	QTY
1	7443000129	Reducer	2
2	7445060648	Tee	4
3	4567123033	Hose Assembly	2
4	4567122030	Hose Assembly	2
5	7935000305	Counterbalance Valve	2
6	7445060645	Elbow	4
7	4567122014	Hose Assembly (manual grids)	2
	4567122014	Hose Assembly (hyd grid - low frame)	
	4567122012	Hose Assembly (hyd grid - high frame)	
8	7445040843	Adapter	2
9	4567110032	Hose Assembly (manual grids)	2
	4567110042	Hose Assembly (hyd grid - low frame)	
	4567110038	Hose Assembly (hyd grid - high frame)	
10	7445040446	Elbow	2
11	7443040843	Adapter	2
12	4567110038	Hose Assembly (manual grids)	2
	4567110038	Hose Assembly (hyd grid - low frame)	
	4567110034	Hose Assembly (hyd grid - high frame)	
13	7445040445	Elbow	10
14	7912000237	Tube Assembly	2
15	4570000234	Hose Assembly	2
16	4619000013	Manifold	1
17	7445040443	Adapter	4
18	7912000184	Tube Assembly	4
19	4570000210	Hose Assembly	2
20	4570000211	Hose Assembly	2

HYDRAULIC COMPONENTS - LB IRL WHEEL LIFT WITH HYDRAULIC GRIDS

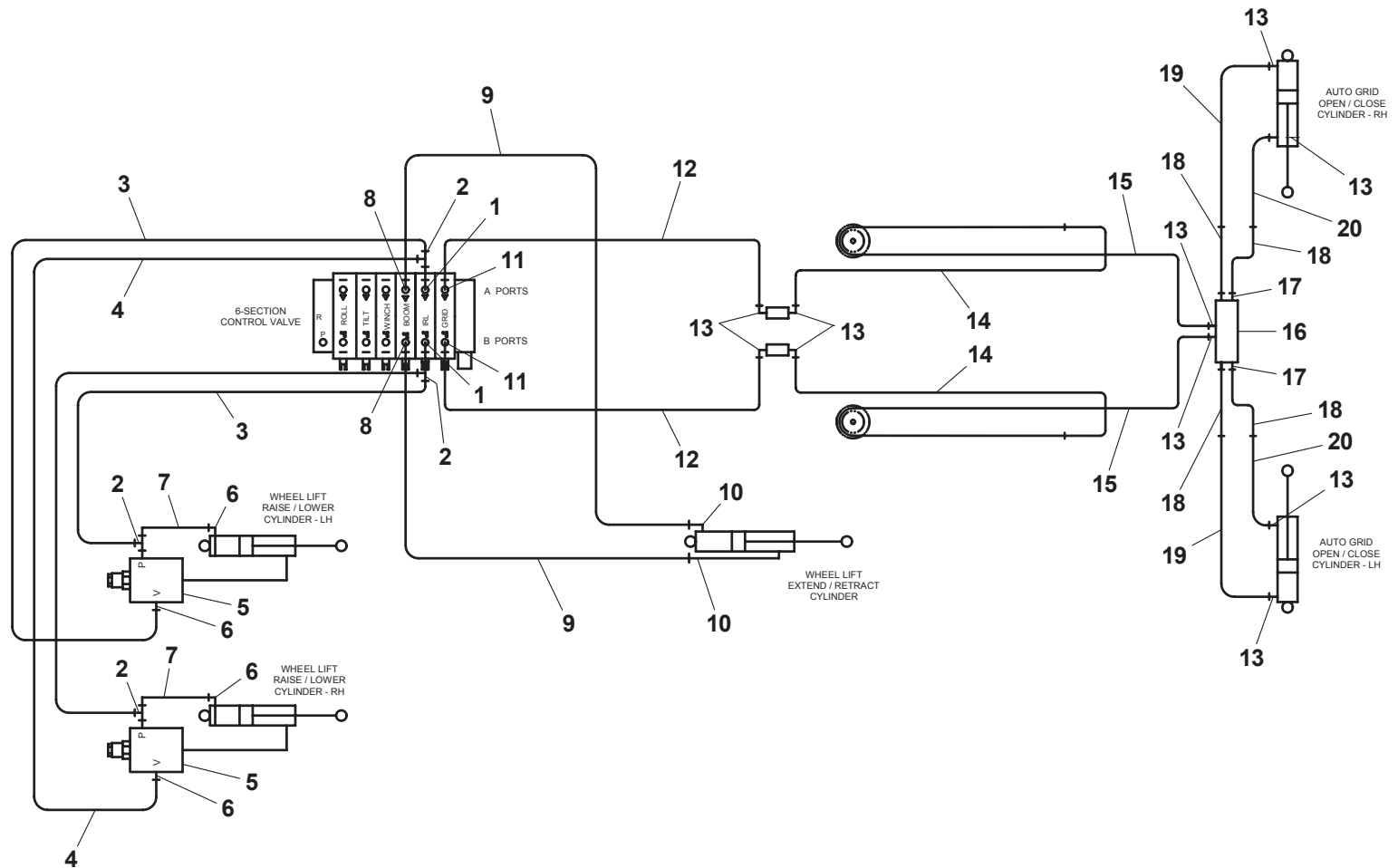

HYDRAULIC COMPONENTS - ZOD WHEEL LIFT WITH MANUAL GRIDS

ITEM	PART NO.	DESCRIPTION	QTY
1	7443000129	Reducer	2
2	7445060648	Tee	4
3	4567123033	Hose Assembly	2
4	4567122030	Hose Assembly	2
5	7935000305	Counterbalance Valve	2
6	7445060645	Elbow	4
7	4567122014	Hose Assembly	2
8	7445060843	Adapter	2
9	4567120025	Hose Assembly	2
10	7445060643	Adapter	4
11	7445040843	Adapter	2
12	4567110034	Hose Assembly	2
13	7445040446	Elbow	2

HYDRAULIC COMPONENTS - ZOD WHEEL LIFT WITH MANUAL GRIDS

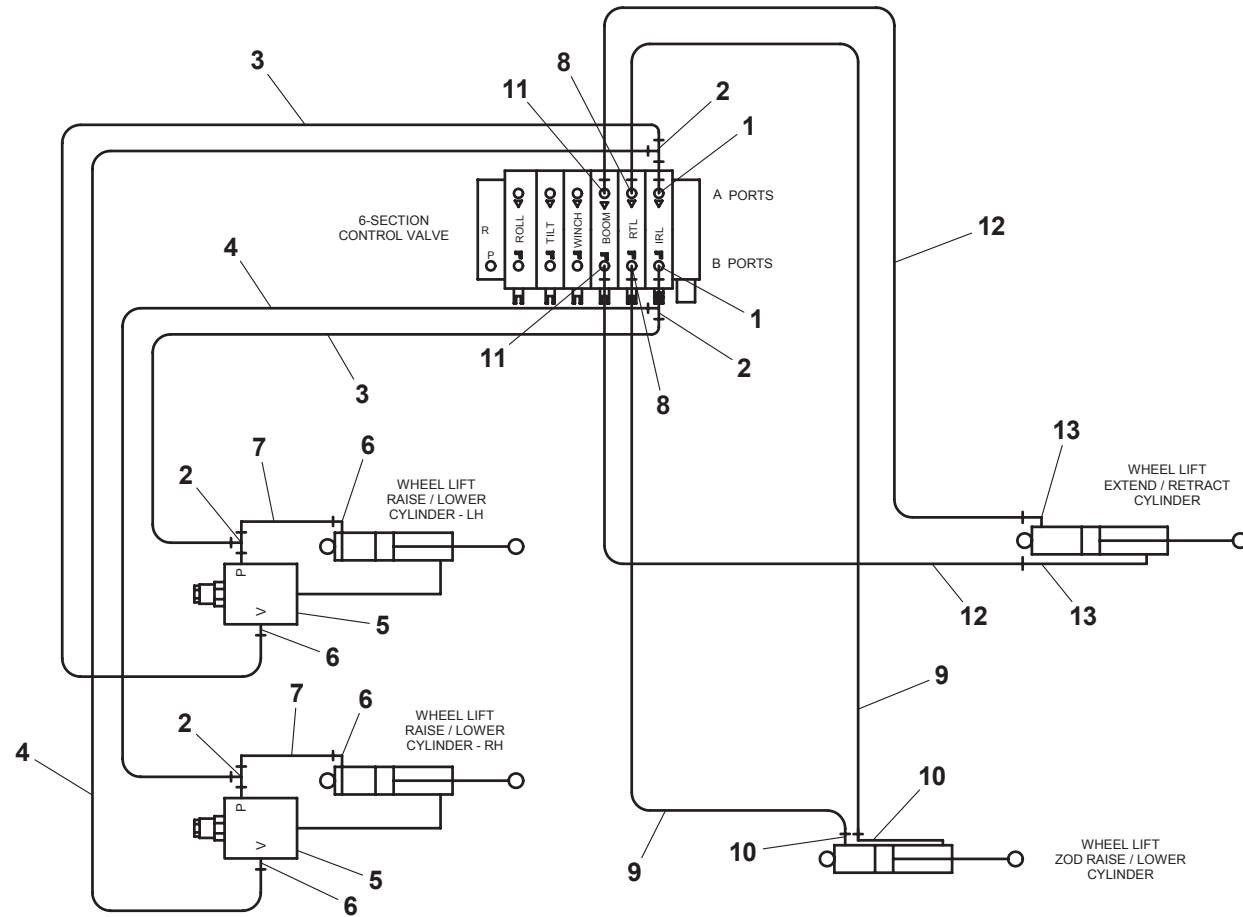

HYDRAULIC COMPONENTS - ZOD WHEEL LIFT WITH HYDRAULIC GRIDS

ITEM	PART NO.	DESCRIPTION	QTY
1	7443000129	Reducer	2
2	7445060648	Tee	4
3	4567123033	Hose Assembly	2
4	4567122030	Hose Assembly	2
5	7935000305	Counterbalance Valve	2
6	7445060645	Elbow	4
7	4567122014	Hose Assembly (manual grids)	2
	4567122014	Hose Assembly (hyd grid - low frame)	
	4567122012	Hose Assembly (hyd grid - high frame)	
8	7445060843	Adapter	2
9	4567120025	Hose Assembly	2
10	7443060643	Adapter	2
11	7445040843	Adapter	2
12	4567110032	Hose Assembly (manual L-grids)	2
	4567110042	Hose Assembly (hyd grid - low frame)	
	4567110038	Hose Assembly (hyd grid - high frame)	
13	7445040446	Elbow	2
14	7443040843	Adapter	2
15	4567110038	Hose Assembly (manual grids)	2
	4567110038	Hose Assembly (hyd grid - low frame)	
	4567110034	Hose Assembly (hyd grid - high frame)	
16	7445040445	Elbow	10
17	7912000237	Tube Assembly	2
18	4570000234	Hose Assembly	2
19	4619000013	Manifold	1
20	7445040443	Adapter	4
21	7912000184	Tube Assembly	4
22	4570000210	Hose Assembly	2
23	4570000211	Hose Assembly	2

HYDRAULIC COMPONENTS - ZOD WHEEL LIFT WITH HYDRAULIC GRIDS

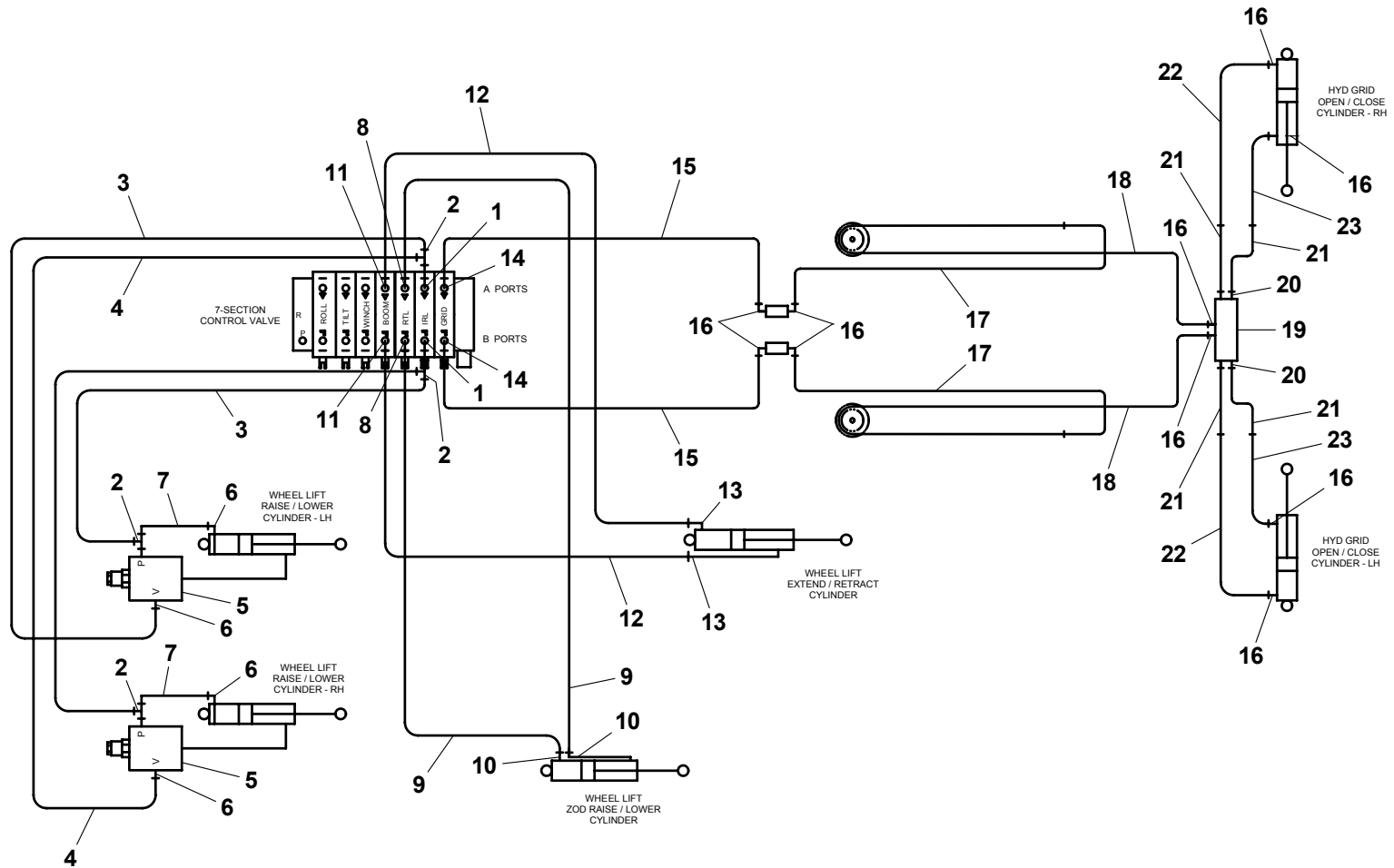

HYDRAULIC COMPONENTS - HYDRAULIC REAR DOCK STABILIZER

ITEM	PART NO.	DESCRIPTION	QTY
1	7445060843	Adapter	2
2	4567122017	Hose Assembly	2
3	7445060637	Tee	2
4	4567120016	Hose Assembly	2
5	4567120026	Hose Assembly	2
6	7445060645	Elbow	4

HYDRAULIC COMPONENTS - HYDRAULIC REAR DOCK STABILIZER

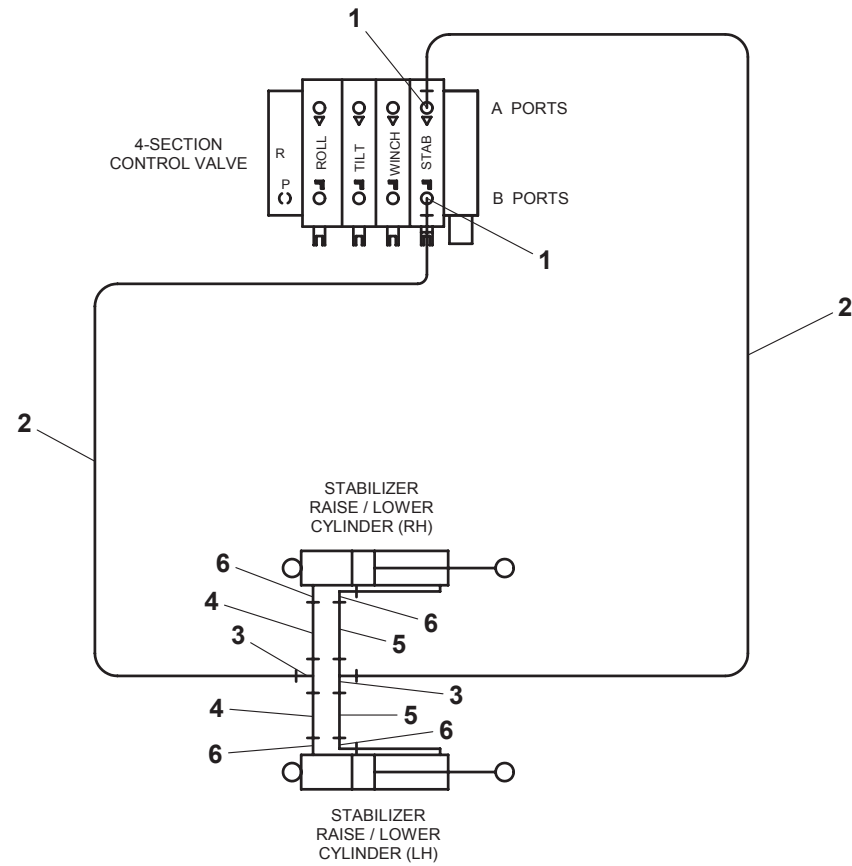

HYDRAULIC COMPONENTS - STABILIZER W/ REESE HITCH RECEIVER OR PINTLE HITCH MTG PLT

ITEM	PART NO.	DESCRIPTION	QTY
1	7445060845	Elbow	2
2	7443000030	Tee	2
3	4567122031	Hose Assembly	2
4	4567122050	Hose Assembly	2
5	7935000305	Counterbalance Valve	2
6	7445060648	Tee	2
7	7445060645	Elbow	4
8	4567122014	Hose Assembly	2

HYDRAULIC COMPONENTS - STABILIZER W/ REESE HITCH RECEIVER OR PINTLE HITCH MTG PLT

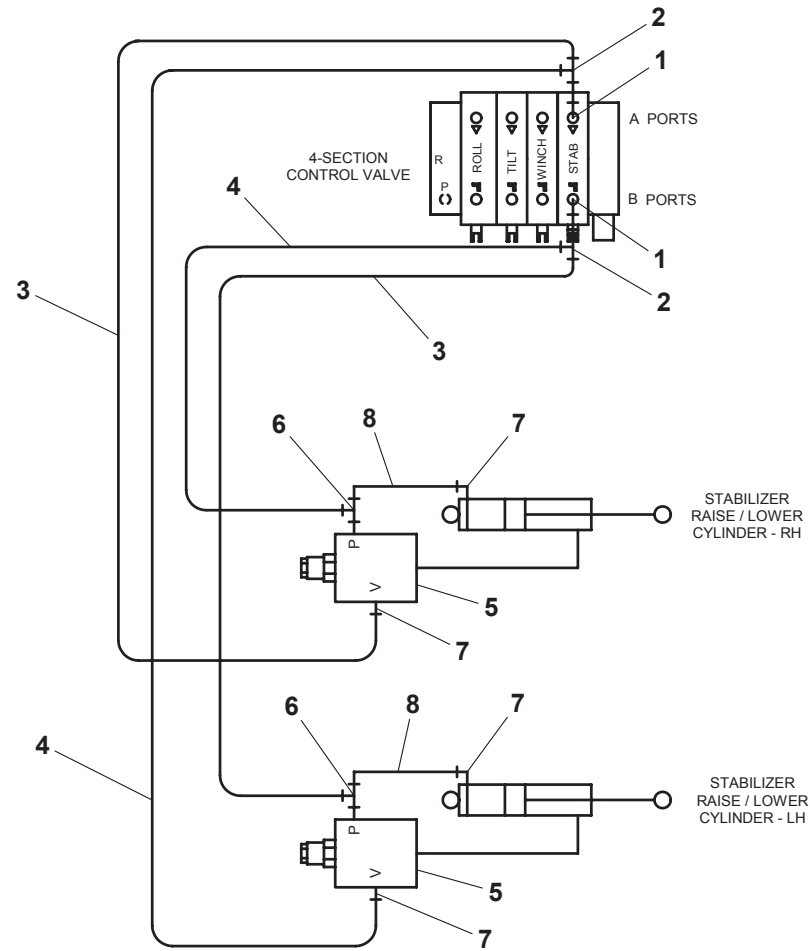

HYDRAULIC COMPONENTS - STABILIZER W/ HYDRAULIC PINTLE HITCH MOUNTING PLATE

ITEM	PART NO.	DESCRIPTION	QTY
1	7445060843	Adapter	2
2	7445060845	Elbow	2
3	7443000030	Tee	2
4	4567122031	Hose Assembly	2
5	4567122050	Hose Assembly	2
6	7935000305	Counterbalance Valve	2
7	7445060645	Elbow	4
8	7445060648	Tee	2
9	4567122014	Hose Assembly	2
10	4567120024	Hose Assembly	2
11	7445060643	Adapter	2

HYDRAULIC COMPONENTS - STABILIZER W/ HYDRAULIC PINTLE HITCH MOUNTING PLATE

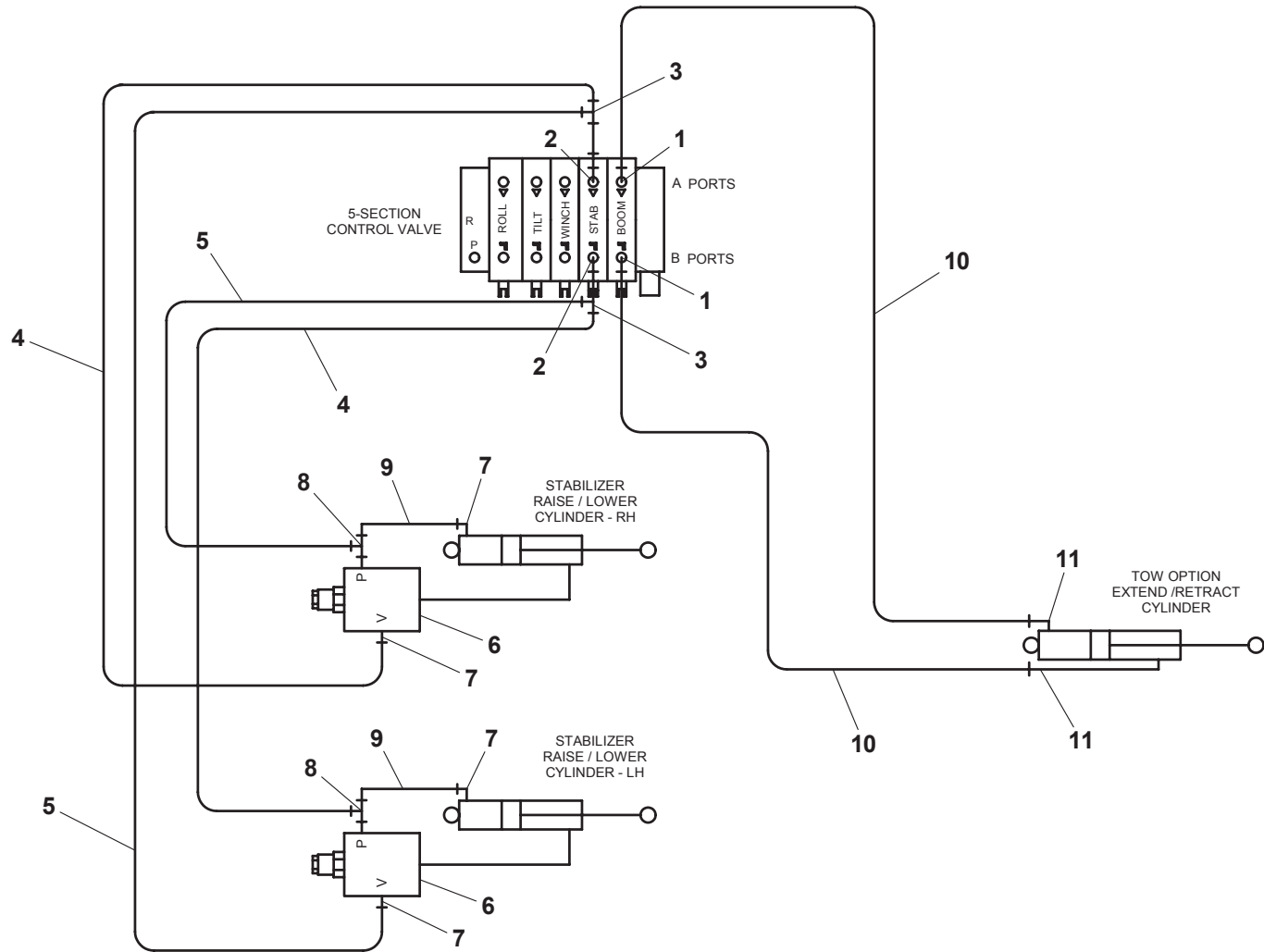

HYDRAULIC COMPONENTS - IRL TOW OPTION

ITEM	PART NO.	DESCRIPTION	QTY
1	7443000129	Reducer	2
2	7445060648	Tee	4
3	4567123033	Hose Assembly	2
4	4567122030	Hose Assembly	2
5	7935000305	Counterbalance Valve	2
6	7445060645	Elbow	4
7	4567122014	Hose Assembly	2
8	7445040843	Adapter	2
9	4567112042	Hose Assembly	2
10	7445040645	Elbow	2

HYDRAULIC COMPONENTS - IRL TOW OPTION

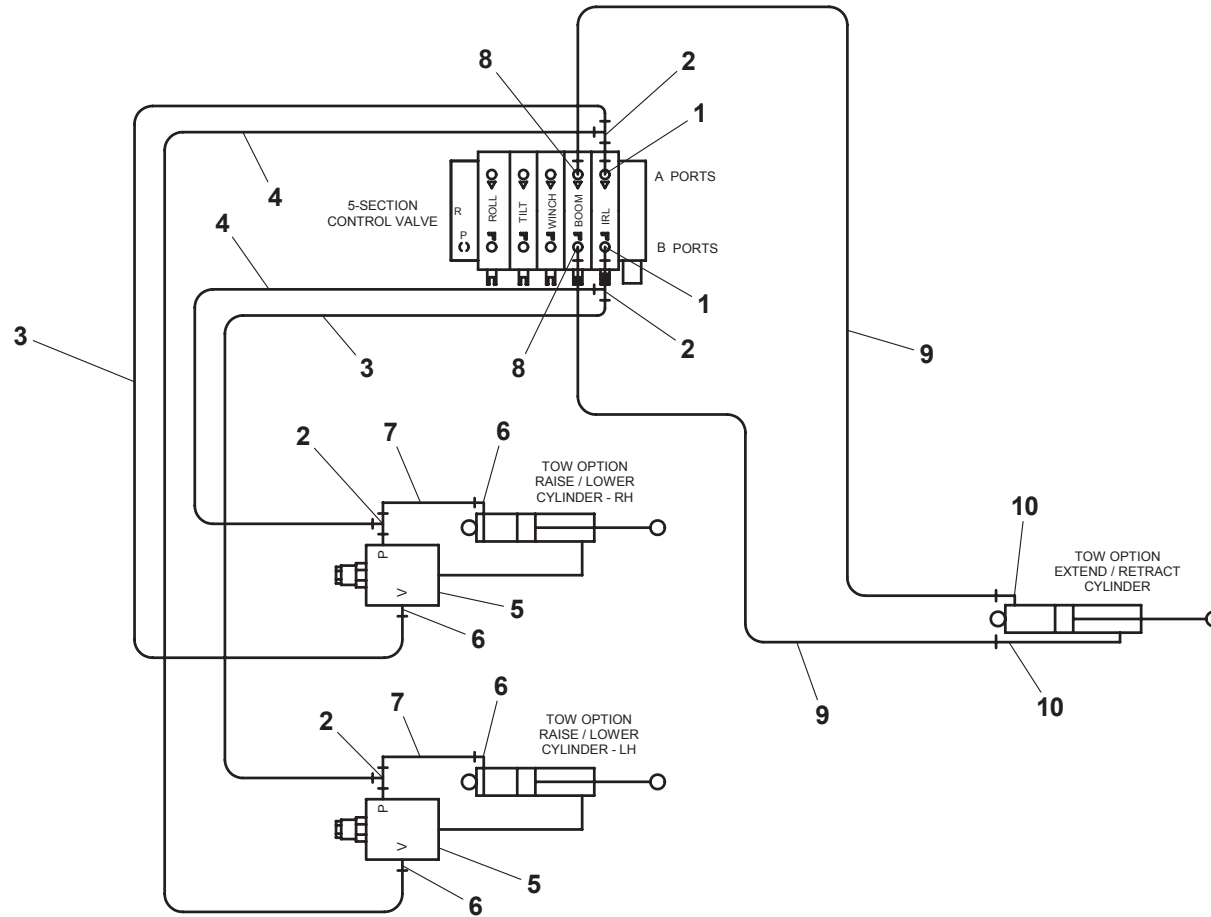

HYDRAULIC COMPONENTS - HYDRAULIC EXTEND TOW OPTION

ITEM	PART NO.	DESCRIPTION	QTY
1	7445040843	Adapter	2
2	4567112042	Hose Assembly	2
3	7445040645	Elbow	2

HYDRAULIC COMPONENTS - HYDRAULIC EXTEND TOW OPTION

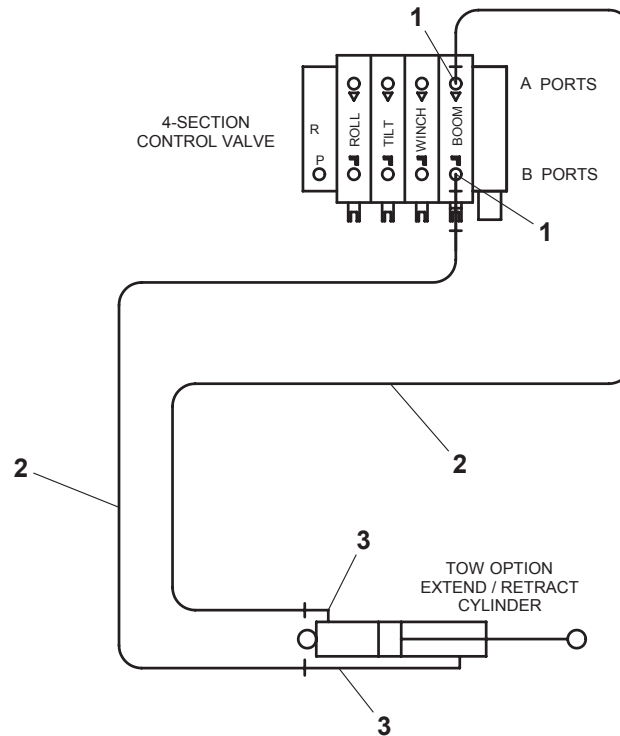

ELECTRICAL COMPONENTS - STANDARD W/ BOLT-ON HEADBOARD

ITEM	PART NO.	DESCRIPTION	QTY
1	7552000098	Subframe to Deck Harness	1
2	7552000074	Subframe to Cab Harness	1
3	7552000126	Subframe Harness	1
4	7552000177	Deck Harness	1
5	7552000166	Winch Lights Harness	1
6	7552000222	Worklights on Headboard Harness	1
7	7345241902	Terminal	1
8	7457000004	Circuit Breaker	1
9	7790100856	Screw, #10 x 0.50"	2
10	7345221902	Terminal	2
11	7950100151	Flatwasher, 0.19" ID	2
12	7280000013	Clip	*
13	3590000015	Wiring Connector Kit (Ford & GMC chassis)	1
	3590000017	Wiring Connector Kit (UD chassis)	

* Quantity varies depending on deck construction.

ELECTRICAL COMPONENTS - STANDARD W/ BOLT-ON HEADBOARD

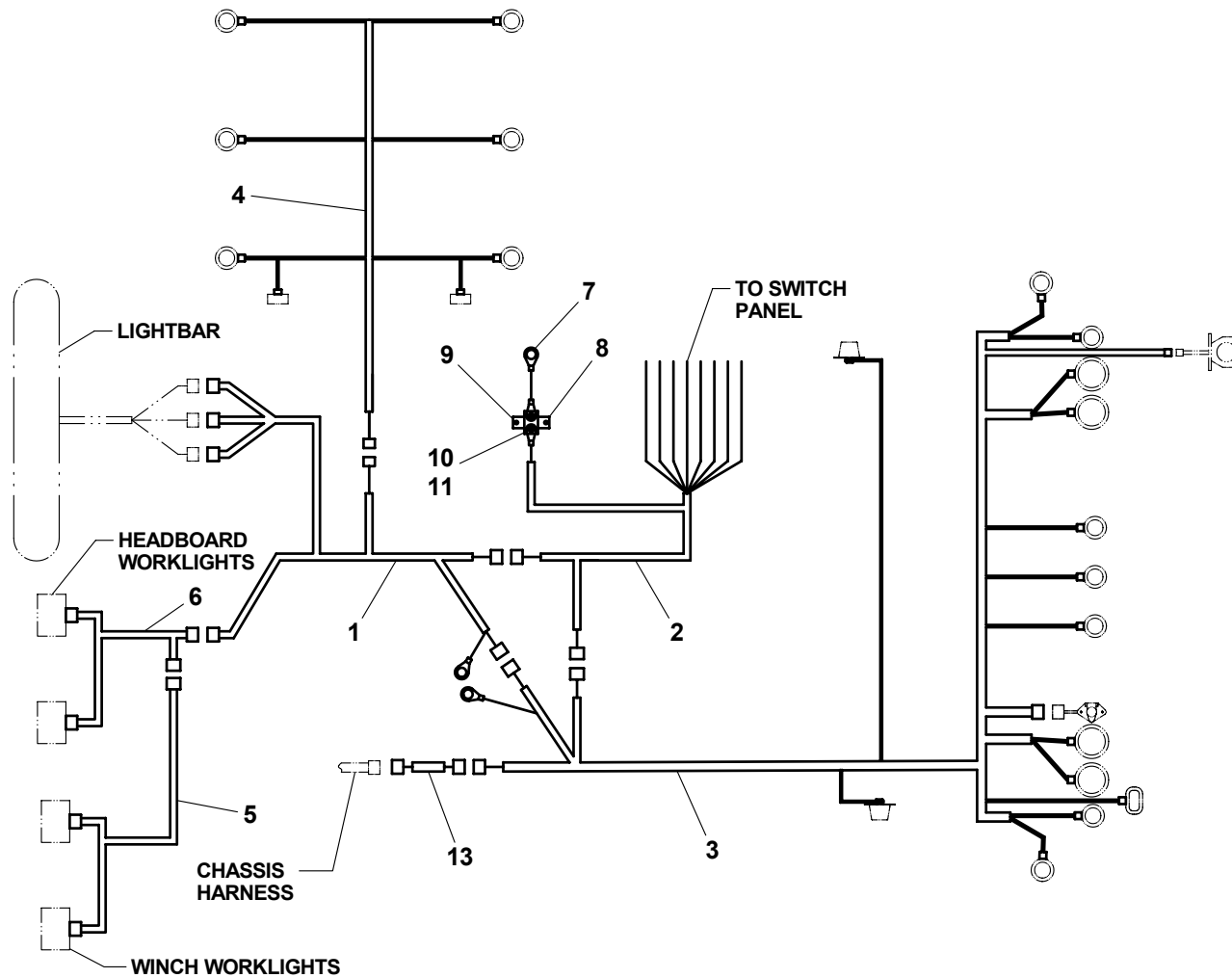

Item #12, Clip, not shown.

ELECTRICAL COMPONENTS - STANDARD W/ STATIONARY HEADBOARD

ITEM	PART NO.	DESCRIPTION	QTY
1	7552000204	Subframe to Cab Harness	1
2	7552000075	Subframe to Deck Harness	1
3	7552000126	Subframe Harness	1
4	7552000177	Deck Harness	1
5	7552000166	Winch Lights Harness	1
6	7345241902	Terminal	1
7	7457000004	Circuit Breaker	1
8	7790100856	Screw, #10 x 0.50"	2
9	7345221902	Terminal	2
10	7950100151	Flatwasher, 0.19" ID	2
11	7280000013	Clip	*
12	3590000015	Wiring Connector Kit	1

* Quantity varies depending on deck construction.

ELECTRICAL COMPONENTS - STANDARD W/ STATIONARY HEADBOARD

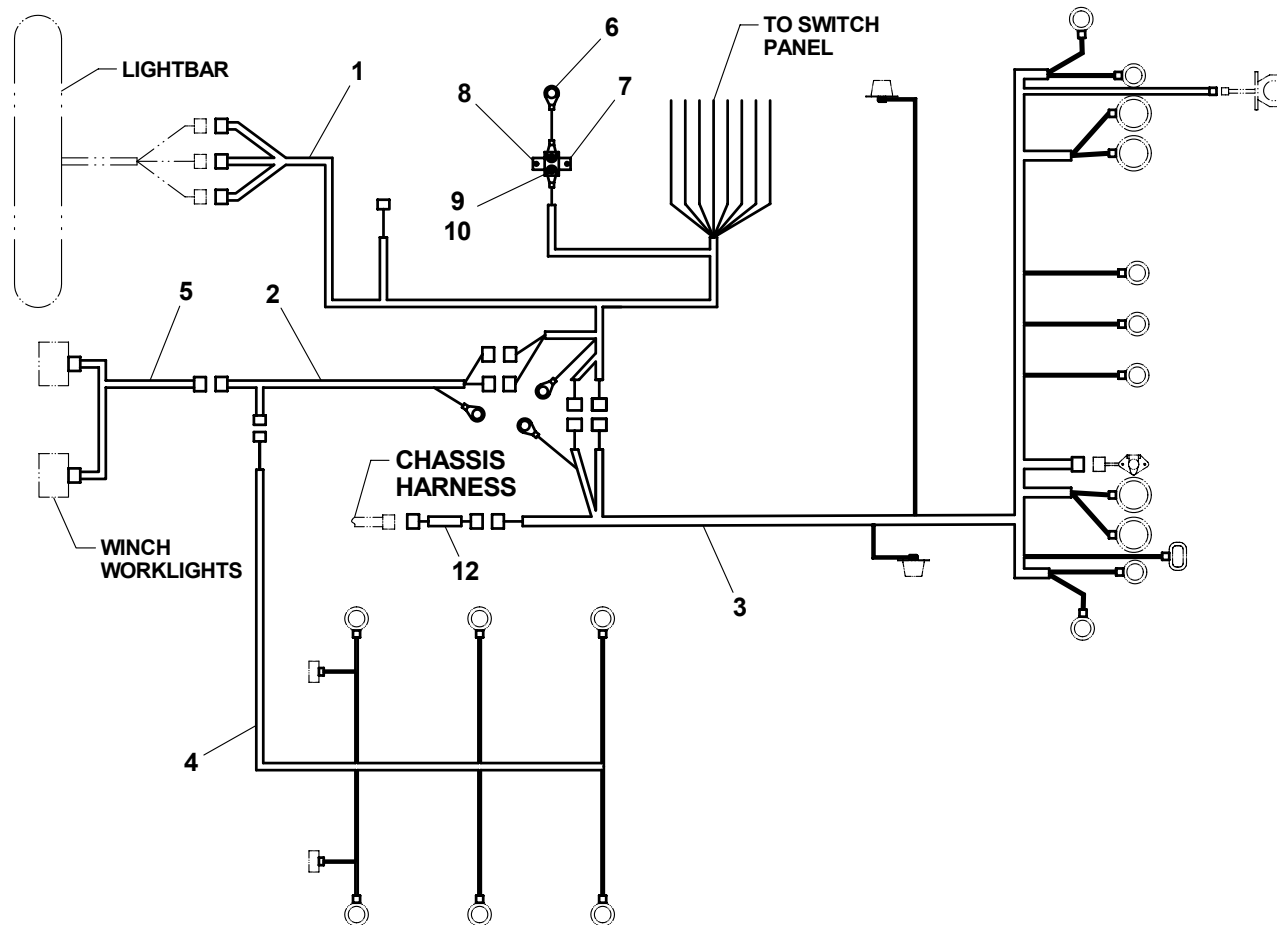

Item #11, Clip, not shown.

ELECTRICAL COMPONENTS - OPTIONAL (TAIL LIGHT CONVERTER)

ITEM	PART NO.	DESCRIPTION	QTY
1	7297000008	Taillight Converter	1
2	4706002990	Plate	1
3	7661000007	Wellnut	4
4	7104100613	Screw, #10-32NF x 0.75"	4
5	7790151253	Screw	2
6	7345001714	Terminal	5
7	4346000005	Heak Shrink Tubing - 1.50"	5
8	7345221902	Terminal	1
9	7345241902	Terminal	1
10	7346000126	Fuse Holder	1
11	7457000017	Fuse - 30 amp	1
12	7345001914	Terminal	1

ELECTRICAL COMPONENTS - OPTIONAL (TAIL LIGHT CONVERTER)

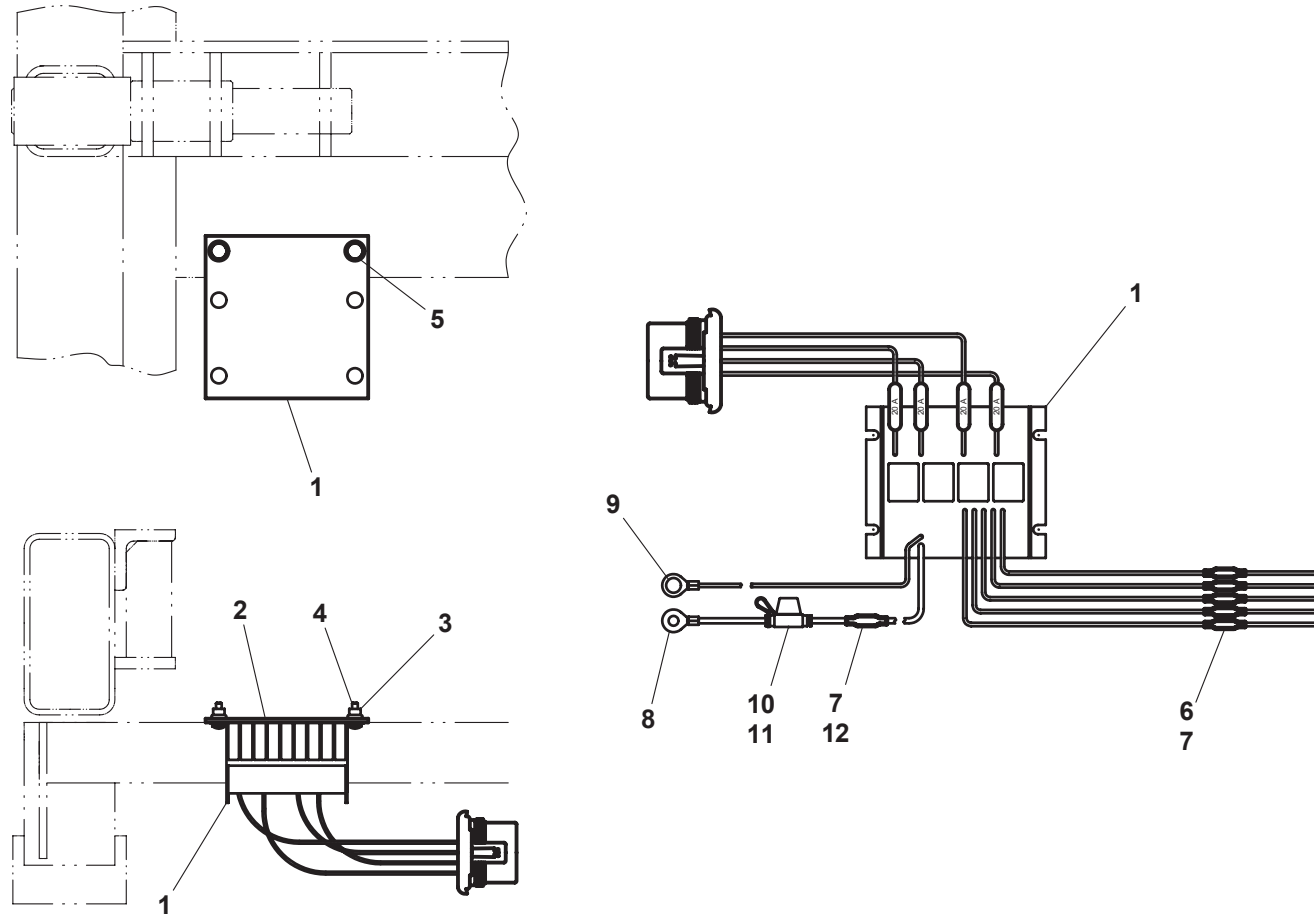

IRL WHEEL LIFT

ITEM	PART NO.	DESCRIPTION	QTY	ITEM	PART NO.	DESCRIPTION	QTY
1	3170000170	Outer Boom Weld (manual grids)	1	25	7796000048	Gasket	1
	3170000332	Outer Boom Weld (hyd grids)		26	7114140528	Screw	2
2	3911000056	Inner Boom Weld	1	27	7660142601	Locknut	2
3	3320000115	Cylinder Assembly	1				
4	4691000296	Pin	1				
5	4691000268	Pin	1				
6	7754000006	Retaining Ring	4				
7	7082000020*	Bushing	1				
8	4679000046	Wear Pad	1				
9	4017000739	Angle	2				
10	7118140418	Capscrew, 0.25"-20NC x 0.50"	4				
11	7950100151	Washer, 0.19" ID	4				
12	4679000211	Wear Pad	1				
13	3320000114	Cylinder Assembly (manual grids)	1				
	3320000134	Cylinder Assembly (hyd grids - low frame)					
	3320000114	Cylinder Assembly (hyd grids - high frame)					
14	3691000164	Pin Weld	2				
15	7115160950	Capscrew, 0.38"-16NC x 1.12"	6				
16	7660162601	Locknut, 0.38"-16NC	6				
17	3691000073	Pin Weld	3				
18	3020000097	Arm Weld (manual grids)	2				
	3020000110	Arm Weld (hyd grids - low frame)					
	3020000097	Arm Weld (hyd grids - high frame)					
19	7082000017+	Bearing	2				
20	7082000018+	Bearing	2				
21	3592000036	Link Assembly (manual grids)	1				
	3592000054	Link Assembly (hyd grids)					
22	3691000069	Pin Weld (manual grids)	1				
	3691000092	Pin Weld (hyd grids)					
23	7082000016^	Bearing	4				
24	7291000010	4-Way Receptacle	1				

* included in Inner Boom Weld, P/N 3911000056

+ included in Arm Weld, P/Ns 3020000097 & 3020000110

^ included in Link Weld, P/Ns 3592000036 & 3592000092

IRL WHEEL LIFT

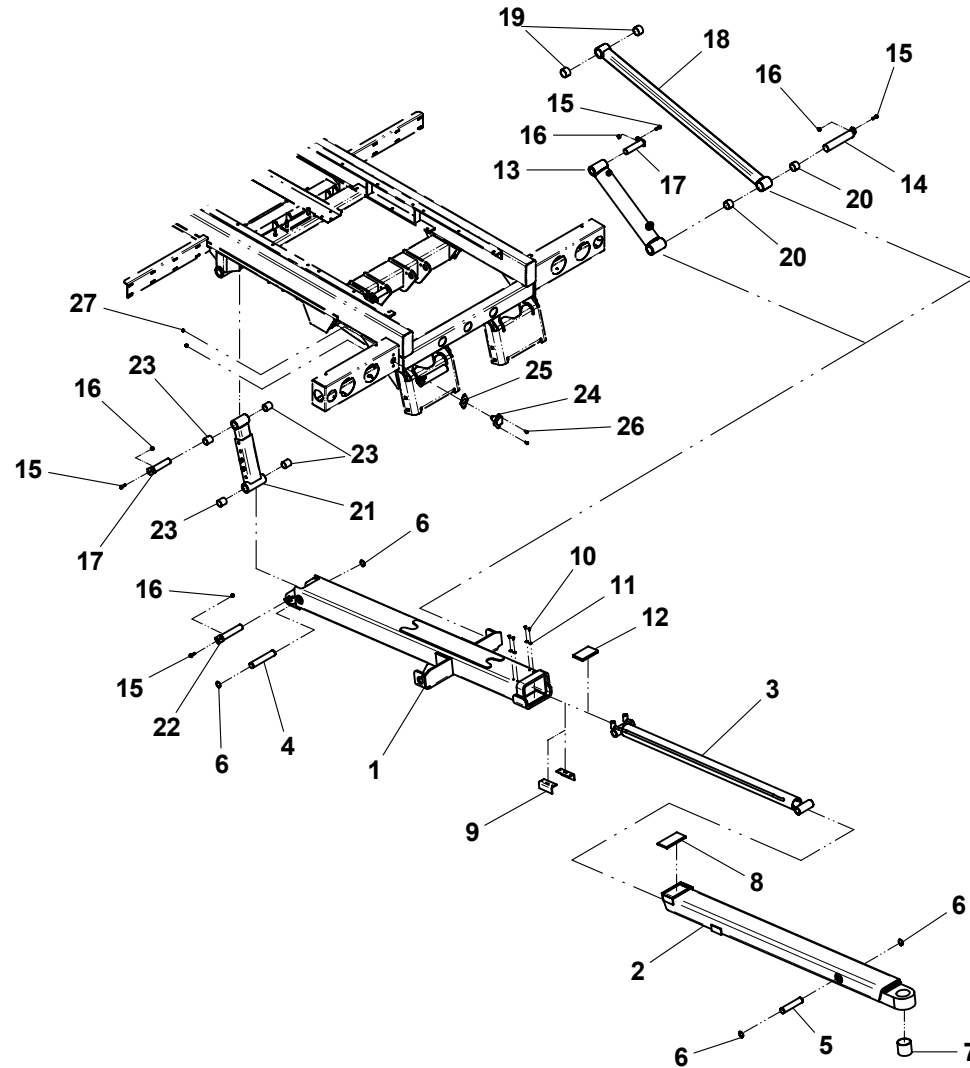

ZOD WHEEL LIFT

ITEM	PART NO.	DESCRIPTION	QTY	ITEM	PART NO.	DESCRIPTION	QTY
1	3170000237	Outer Boom Weld (manual grids)	1	24	7796000048	Gasket	1
	3170000332	Outer Boom Weld (hydraulic grids)		25	7114140528	Screw	2
2	3911000056	Inner Boom Weld	1	26	7660142601	Locknut	2
3	3320000115	Cylinder Assembly	1				
4	4691000296	Pin	1				
5	4691000268	Pin	1				
6	7754000006	Retaining Ring	4				
7	7082000020*	Bushing	1				
8	4679000046	Wear Pad	1				
9	4017000739	Angle	2				
10	7118140418	Capscrew, 0.25"-20NC x 0.50"	4				
11	7950100151	Washer, 0.19" ID	4				
12	4679000211	Wear Pad	1				
13	3320000114	Cylinder Assembly (manual grids)	2				
	3320000134	Cylinder Assembly (hyd grids - low frame)					
	3320000114	Cylinder Assembly (hyd grids - high frame)					
14	3691000164	Pin Weld	2				
15	7115160950	Capscrew, 0.38"-16NC x 1.12"	6				
16	7660162601	Locknut, 0.38"-16NC	6				
17	3691000073	Pin Weld	3				
18	3020000097	Arm Weld (manual grids)	2				
	3020000110	Arm Weld (hydraulic grids - low frame)					
	3020000097	Arm Weld (hydraulic grids - high frame)					
19	7082000017+	Bearing	2				
20	7082000018+	Bearing	2				
21	3320000118	Cylinder Assembly (manual grids)	1				
	3320000135	Cylinder Assembly (hyd grids - low frame)					
	3320000157	Cylinder Assembly (hyd grids - high frame)					
22	3691000069	Pin Weld (manual grids)	1				
	3691000092	Pin Weld (hydraulic grids)					
23	7291000010	4-Way Receptacle	1				

* included in Inner Boom Weld, P/N 3911000056

+ included in Arm Welds, P/Ns 3020000097 & 3020000110

ZOD WHEEL LIFT

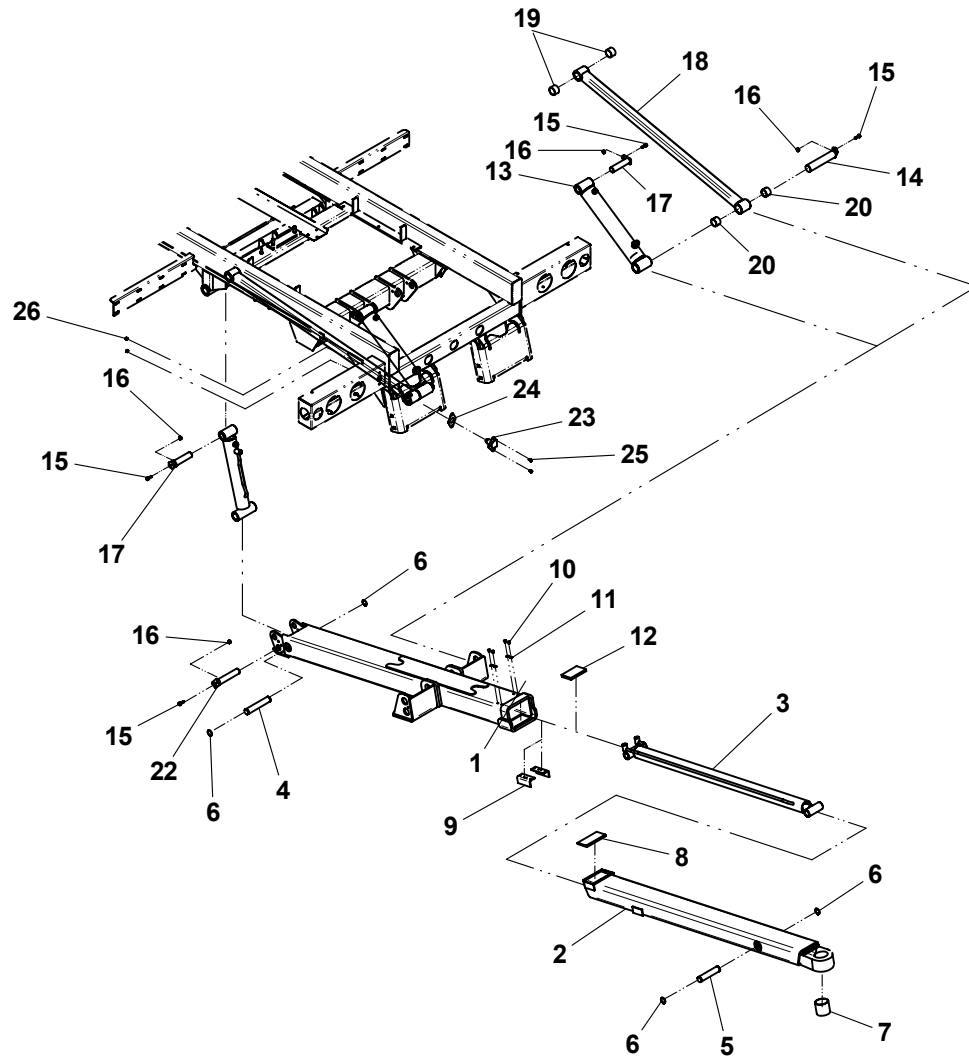

MANUAL L-ARM WHEEL LIFT GRID

ITEM	PART NO.	DESCRIPTION	QTY
1	3913000093	Pivot Tube Weld (3,000 lb IRL wheel lift w/ ball plate)	1
	3913000096	Pivot Tube Weld (3,000 lb ZOD wheel lift w/ ball plate)	
	3913000098	Pivot Tube Weld (3,000 lb IRL wheel lift w/ pintle plate)	
	3913000099	Pivot Tube Weld (3,000 lb ZOD wheel lift w/ pintle plate)	
2	3484000035	Grid Weld - LH	1
3	3484000034	Grid Weld - RH	1
4	4691000447	Pivot Pin	1
5	4949000047	Washer	2
6	7754000024	Retaining Ring	1
7	3551000036	T-Handle	2
8	3020000072	L-Arm Weld	2
9	7701000062	Plug	2
10	3551000011	Cam Lock Assembly	2
11	7440030000	Grease Fitting	2
12	7330000419	Reflective Tape	2
13	7330000417	Reflective Tape - LH	1
14	7330000418	Reflective Tape - RH	1

MANUAL L-ARM WHEEL LIFT GRID

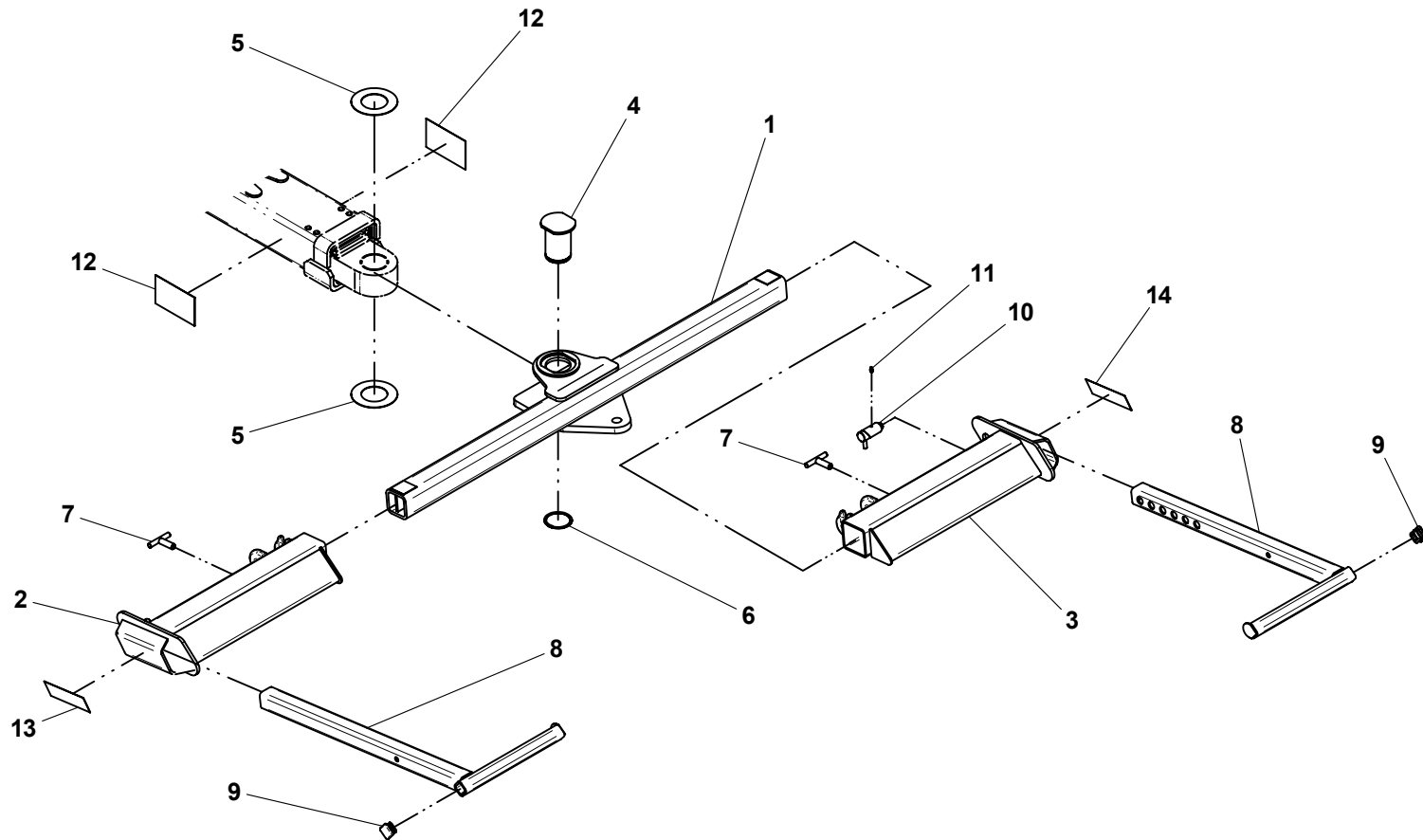

Pivot tube weld with IRL ball hitch mounting plate shown

MANUAL T37 PIVOTING WHEEL LIFT GRID

ITEM	PART NO.	DESCRIPTION	QTY	ITEM	PART NO.	DESCRIPTION	QTY
1	3913000093	Pivot Tube Weld (3,000 lb IRL wheel lift w/ ball plate)	1	25	7330000432	Reflective tape	1
	3913000096	Pivot Tube Weld (3,000 lb ZOD wheel lift w/ ball plate)		26	7950200000	Lockwasher, 0.63" ID	2
	3913000098	Pivot Tube Weld (3,000 lb IRL wheel lift w/ pintle plate)					
	3913000099	Pivot Tube Weld (3,000 lb ZOD wheel lift w/ pintle plate)					
2	3484000051*	Grid Weld - LH	1				
3	3484000050+	Grid Weld - RH	1				
4	4259000002*	Pivot Casting, LH	1				
5	4259000001+	Pivot Casting, RH	1				
6	4691000354*+	Pin	2				
7	4691000357*+	Pin	2				
8	7754000037*+	Retaining Ring	2				
9	3551000036	T-Handle	2				
10	4691000186*+	Pin	2				
11	7843000006*+	Spring	2				
12	4763000184*+	Rod	2				
13	4254000005*+	Cap	2				
14	7786000006*+	Screw	2				
15	7843000016*+	Spring	2				
16	4691000183*+	Pin	2				
17	4691000447	Pivot Pin	1				
18	4949000047	Washer	2				
19	7754000024	Retaining Ring	1				
20	7440030000	Grease Fitting	6				
21	3020000029	L-Arm Weld - LH	1				
22	3020000030	L-Arm Weld - RH	1				
23	7330000419	Reflective Tape	2				
24	7330000420	Reflective Tape	1				

* also available in Grid Assembly, LH, P/N 3484000053
 + also available in Grid Assembly, RH, P/N 3484000052

MANUAL T37 PIVOTING WHEEL LIFT GRID

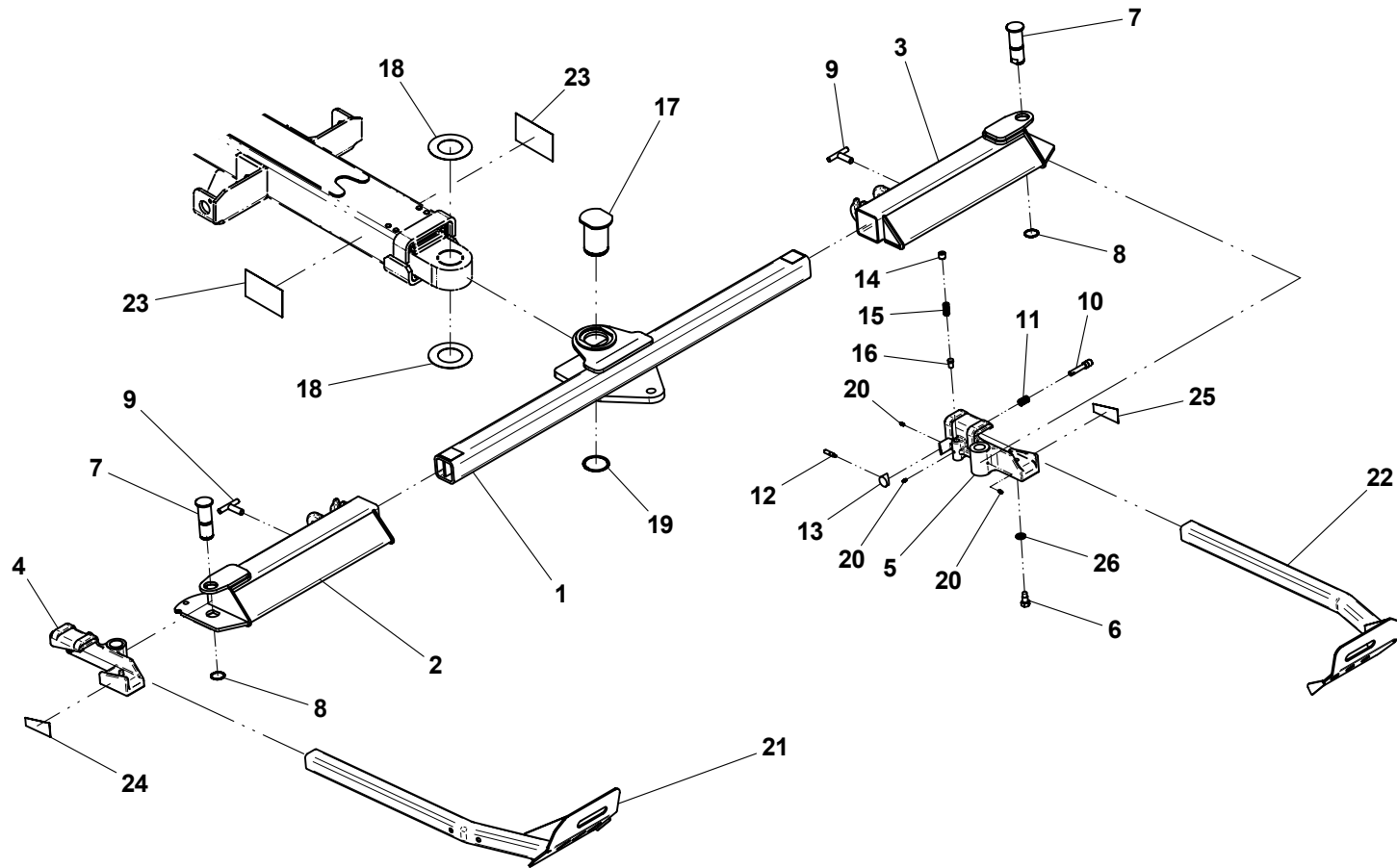

Pivot tube weld with IRL ball hitch mounting plate shown

HYDRAULIC WHEEL LIFT GRID

ITEM	PART NO.	DESCRIPTION	QTY	ITEM	PART NO.	DESCRIPTION	QTY
1	4691000482	Pivot Pin	1	32	4679000268	Pad	1
2	4949000047	Washer	2	33	7118161026	Capscrew, 0.38"-16NC x 1.25"	2
3	7754000024	Retaining Ring	1	34	4314000076*	Coverplate	2
4	3484000074*	Grid Crossbar Weld	1	35	7115140518*	Capscrew, 0.25"-20NC x 0.62"	4
5	7320000064*	Cylinder Assembly	2	36	7785140400*	Set Screw	2
6	3691000229*	Pin Weld	4	37	4619000013*	Manifold	1
7	7115151023*	Capscrew, 0.31"-18NC x 1.25"	6	38	7445040443*	Adapter	4
8	7660152601*	Locknut, 0.31"-18NC	6	39	7912000184*	Tube Assembly	4
9	4691000497*	Pin	2	40	7274000086*	Clamp	4
10	3592000052*	Link Weld	2	41	7274000039*	Cover	2
11	3592000051*	Link Weld	2	42	7115151250*	Capscrew, 0.31"-18NC x 1.50"	2
12	4706003497*	Plate	2	40	4314000117	Cover Plate, LH	1
13	7754000022*	Retaining Ring	4	41	4314000118	Cover Plate, RH	1
14	7330000419	Reflective Tape	2	42	7790151253	Screw, 0.31"-18NC x 0.75"	8
15	3691000230	Pin Weld	2	43	7732000002	Spring Reel	2
16	3020000115*	Arm Weld, LH	1	44	4831000109	Spacer	2
17	3020000111*	Arm Weld, RH	1	45	7719000004	Roller	2
18	7754000087	Retaining Ring	4	46	4706003501	Plate	2
19	7843000043	Extension Spring	2	47	7691000040	Clevis Pin	2
20	7248000115	Cable Assembly	2	48	7691000042	Cotter Pin	2
21	7690141600	Pin	2	49	3619000001	Manifold Weld	2
22	7690021210	Cotter Pin	2	50	7115140850	Capscrew, 0.25"-20NC x 1.00"	4
23	4831000112	Spacer	4	51	7950140153	Flatwasher, 0.25" ID	8
24	7719000005	Pulley	2	52	7660142604	Locknut, 0.25"-20NC	8
25	7690144005	Clevis Pin	2	53	7445040445	Elbow	4
26	3691000222	Pin Weld	2	54	7912000237	Tube	2
27	7115150423	Capscrew, 0.31"-18NC x 0.50"	2	55	7274000073	Hose Clamp	4
28	4949000072	Washer	4	56	7785140870*	Set Screw	2
29	7754000006	Retaining Ring	2	57	4691000527	Pin	2
30	3020000112	Arm Weld	2	58	7082000026^#	Bearing	10
31	3831000029	Wheel Spacer	2	59	7082000027+>	Bearing	6

* also available in Grid Crossbar Assembly, P/N 3484000075

^ also quantity of 8 available in Link Welds, P/N 3592000052

+ also quantity of 2 each available in Arm Weld P/N 3020000115 & P/N 3020000111

also quantity of 1 each available in Arm Weld P/N 3020000115 & 3020000111

> also quantity of 2 available in Arm Welds P/N 3020000112

HYDRAULIC WHEEL LIFT GRID

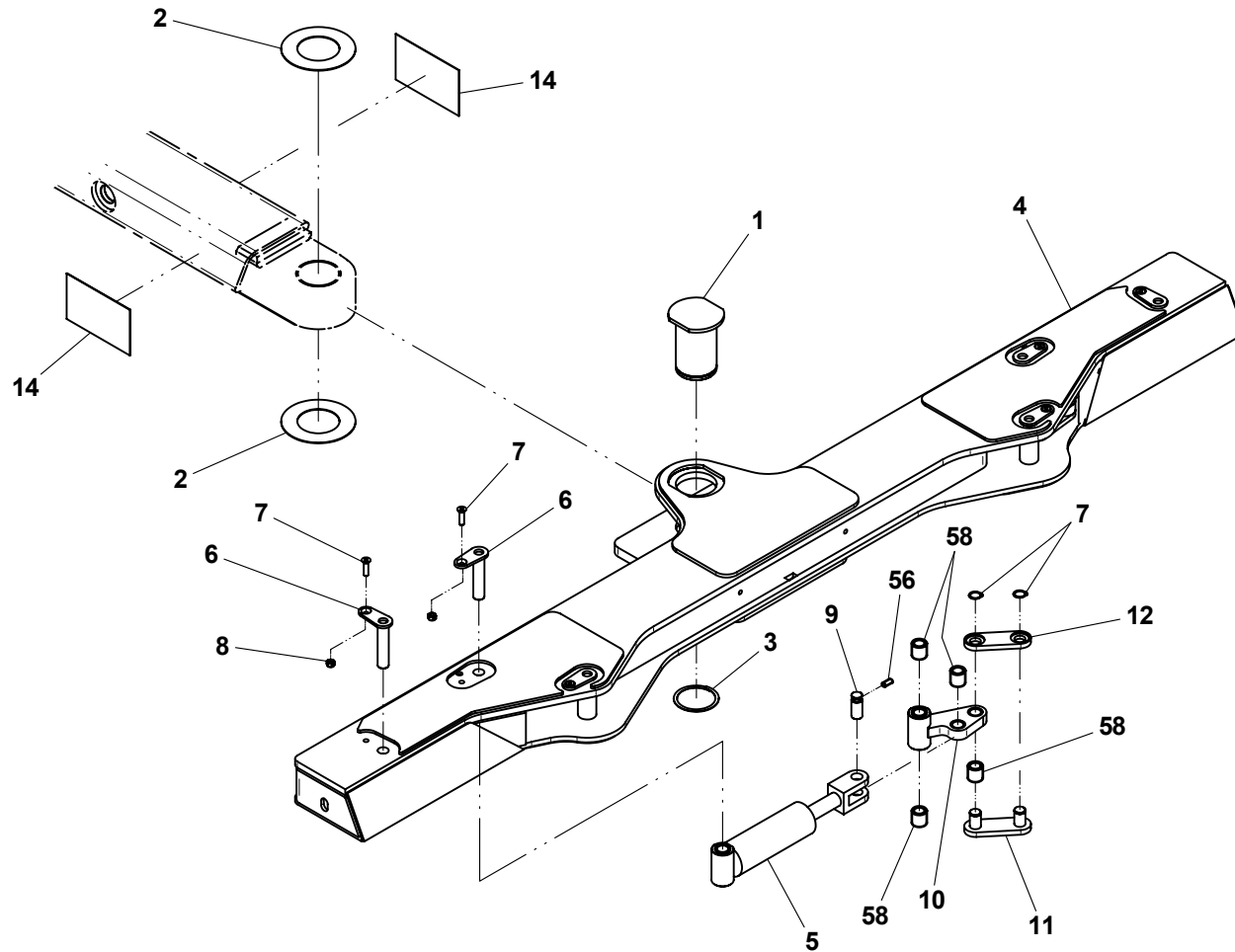

HYDRAULIC WHEEL LIFT GRID

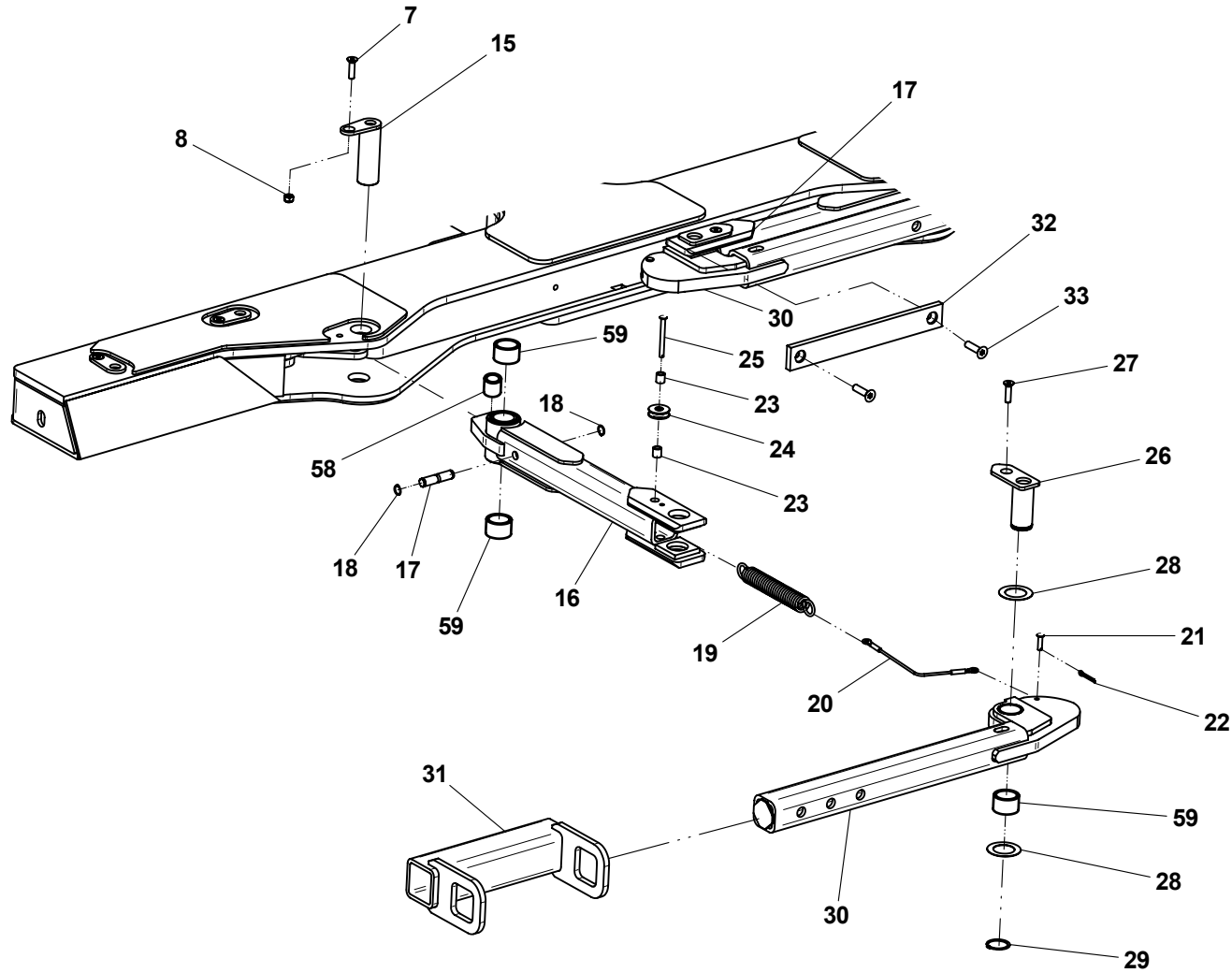

HYDRAULIC WHEEL LIFT GRID

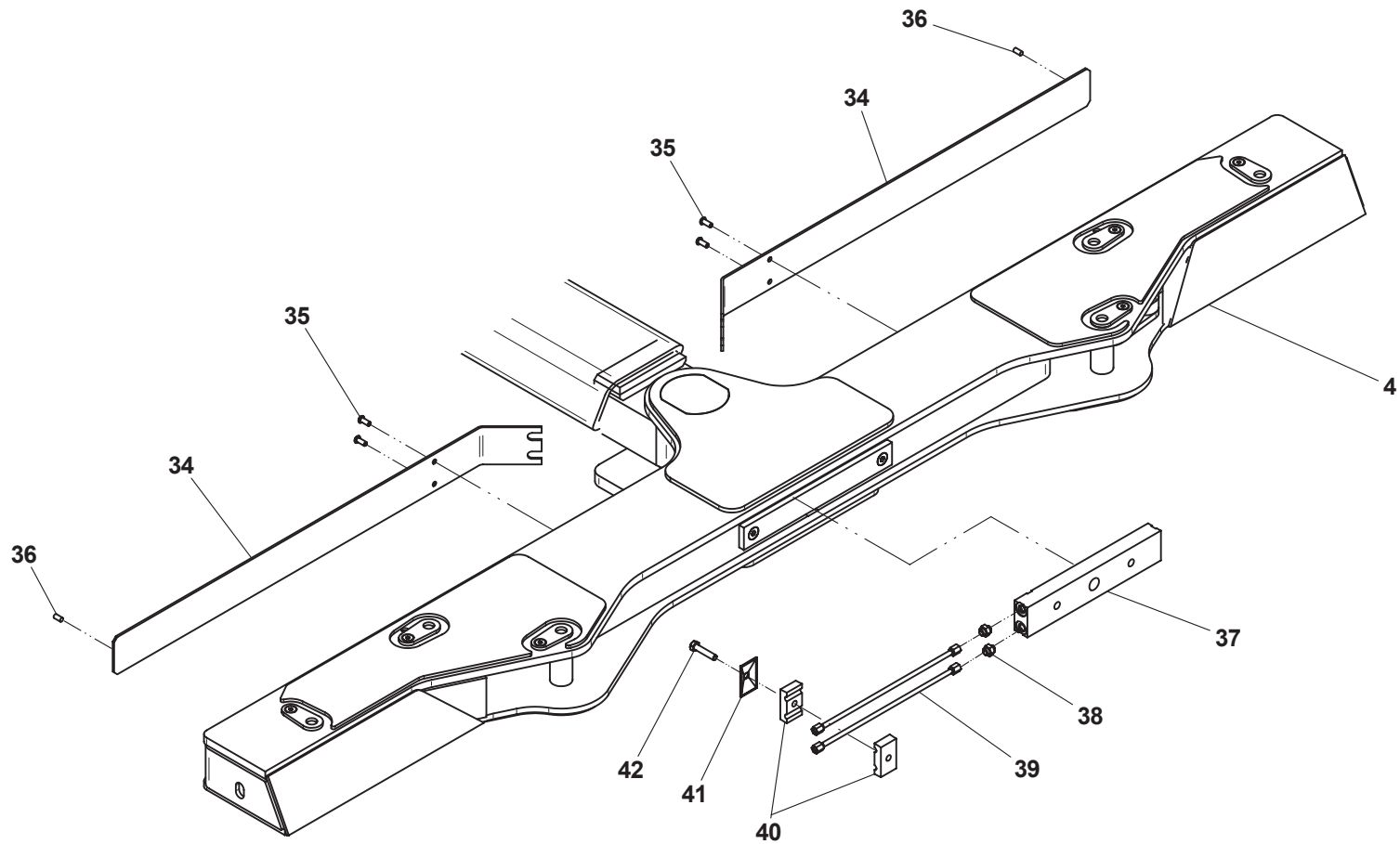

HYDRAULIC WHEEL LIFT GRID

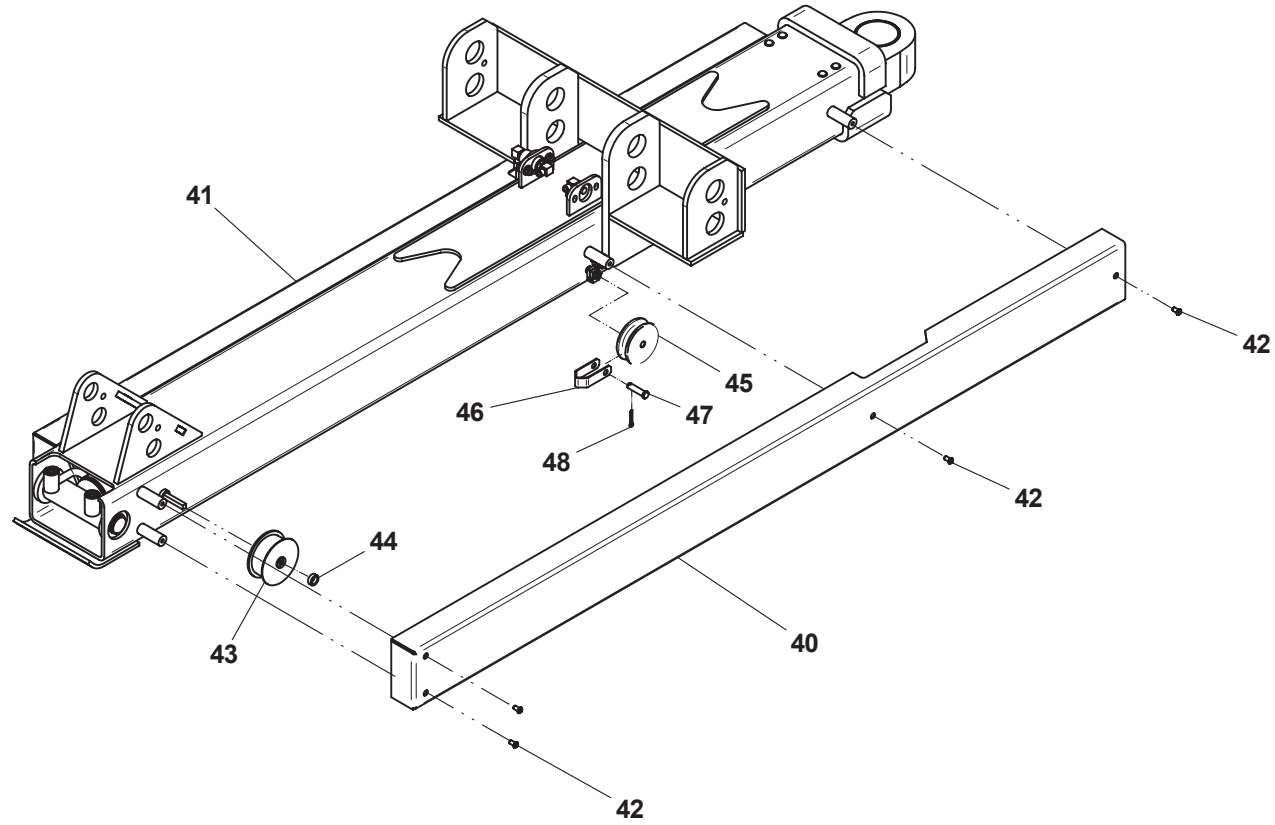

HYDRAULIC WHEEL LIFT GRID

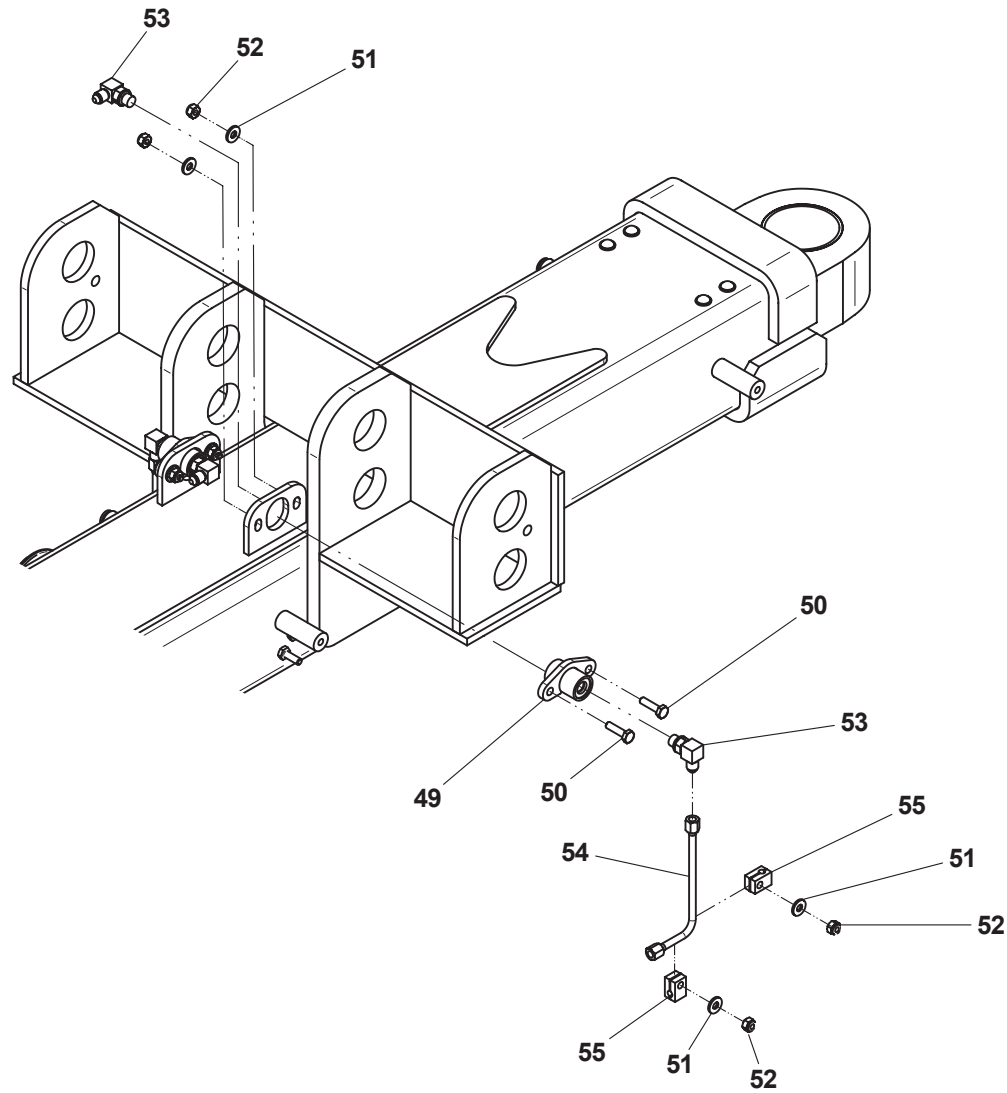

HYDRAULIC REAR DOCK STABILIZER

ITEM	PART NO.	DESCRIPTION	QTY
1	3849000021	Stabilizer Weld	1
2	3320000119	Cylinder Assembly	2
3	3691000165	Pin Weld	2
4	3691000073	Pin Weld	2
5	7115160950	Capscrew, 0.38"-16NC x 1.12"	4
6	7660162601	Locknut, 0.38"-16NC	4
7	7082000017*	Bearing	4

* included in Stabilizer Weld, P/N 3849000021

HYDRAULIC REAR DOCK STABILIZER

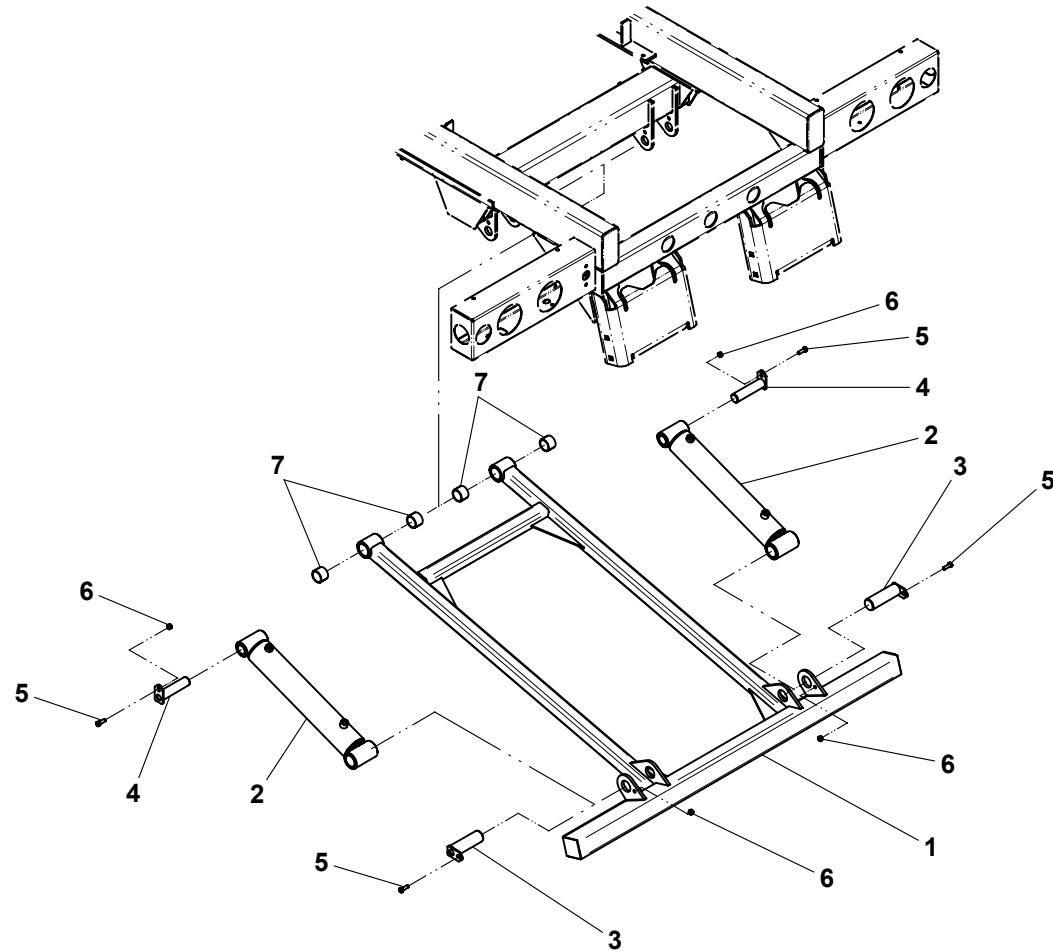

HYDRAULIC REAR DOCK STABILIZER WITH REESE HITCH RECEIVER

ITEM	PART NO.	DESCRIPTION	QTY
1	3849000023	Stabilizer Weld w/ Reese Hitch Receiver	1
2	3320000114	Cylinder Assembly	2
3	3691000165	Pin Weld	2
4	3691000073	Pin Weld	2
5	7115160950	Capscrew, 0.38"-16NC x 1.12"	4
6	7660162601	Locknut, 0.38"-16NC	4
7	7082000017*	Bearing	4
8	7291000010	4-Way Receptacle	1
9	7796000048	Gasket	1
10	7114140528	Screw, 0.25"-20NC x .63"	2
11	7660142601	Locknut, 0.25"-20NC	2

* included in Stabilizer Weld, P/N 3849000023

HYDRAULIC REAR DOCK STABILIZER WITH REESE HITCH RECEIVER

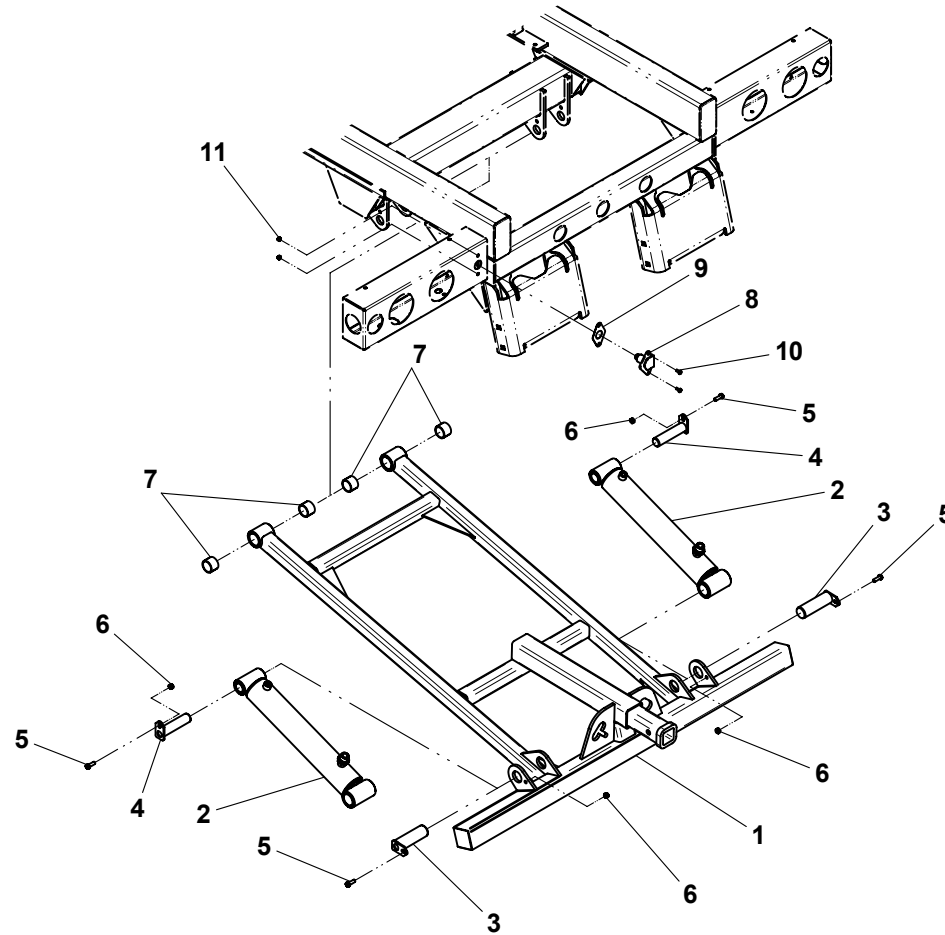

HYDRAULIC REAR DOCK STABILIZER WITH MANUAL EXTEND PINTLE HITCH MOUNTING PLATE

ITEM	PART NO.	DESCRIPTION	QTY
1	3849000022	Stabilizer Weld w/ Manual Pintle Plate	1
2	3320000114	Cylinder Assembly	2
3	3691000165	Pin Weld	2
4	3691000073	Pin Weld	2
5	7115160950	Capscrew, 0.38"-16NC x 1.12"	4
6	7660162601	Locknut, 0.38"-16NC	4
7	3170000203	Inner Boom Weld	1
8	3691000064	Pin Weld	1
9	7691000001	Hair Pin	1
10	7082000017*	Bearing	4
11	7291000010	4-Way Receptacle	1
12	7796000048	Gasket	1
13	7114140528	Screw, 0.25"-20NC x 0.63"	2
14	7660142601	Locknut, 0.25"-20NC	2

* included in Stabilizer Weld, P/N 3849000022

HYDRAULIC REAR DOCK STABILIZER WITH MANUAL EXTEND PINTLE HITCH MOUNTING PLATE

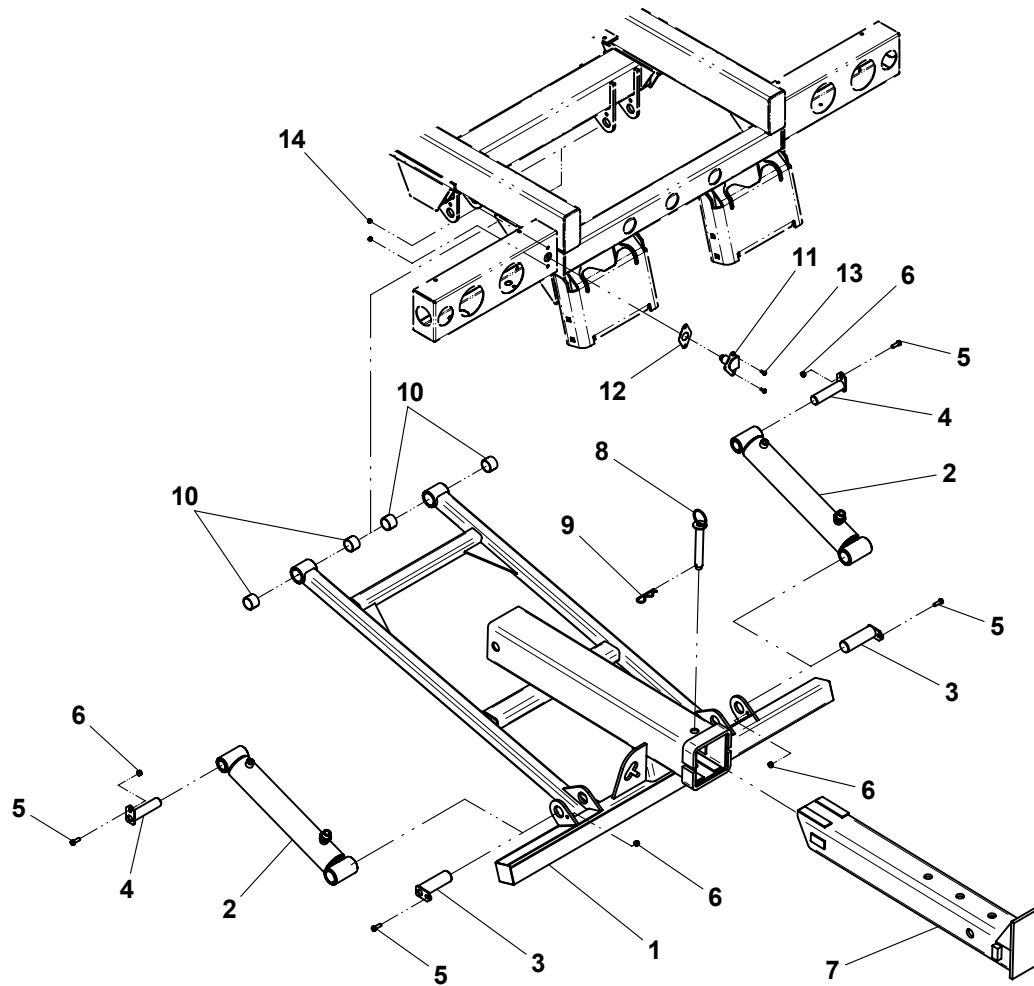

HYDRAULIC REAR DOCK STABILIZER WITH HYDRAULIC EXTEND PINTLE HITCH MOUNTING PLATE

ITEM	PART NO.	DESCRIPTION	QTY
1	3849000022	Stabilizer Weld w/ Pintle Hitch Plate	1
2	3320000114	Cylinder Assembly	2
3	3691000165	Pin Weld	2
4	3691000073	Pin Weld	2
5	7115160950	Capscrew, 0.38"-16NC x 1.12"	4
6	7660162601	Locknut, 0.38"-16NC	4
7	3170000203	Inner Boom Weld	1
8	3691000064	Pin Weld	1
9	7691000001	Hair Pin	1
10	3320000117	Cylinder Assembly	1
11	4691000430	Pin	1
12	4691000429	Pin	1
13	7754000006	Retaining Ring	1
14	7082000017*	Bearing	4
15	7291000003	4-Way Receptacle	1
16	7796000048	Gasket	1
17	7114140528	Screw, 0.25"-20NC x 0.63"	2
18	7660142601	Locknut, 0.25"-20NC	2

* included in Stabilizer Weld, P/N 3849000022

HYDRAULIC REAR DOCK STABILIZER WITH HYDRAULIC EXTEND PINTLE HITCH MOUNTING PLATE

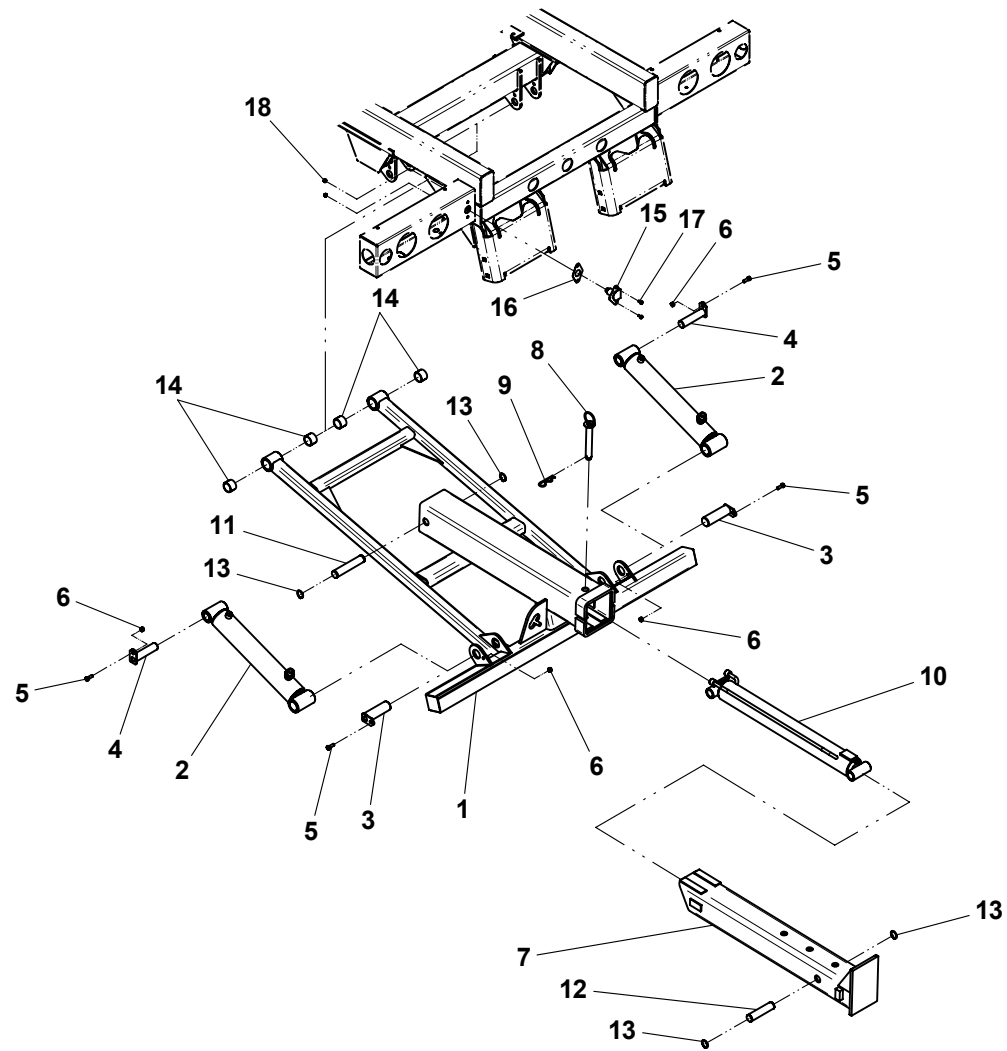

BALL HITCH MOUNTING PLATE - IRL

ITEM	PART NO.	DESCRIPTION	QTY
1	3170000275	Outer Boom Weld	1
2	3911000062	Inner Boom Weld	1
3	3320000116	Cylinder Assembly	1
4	4691000430	Pin	1
5	4691000429	Pin	1
6	7754000006	Retaining Ring	4
7	3691000064	Pin Weld	1
8	7691000001	Hair Pin	1
9	3320000114	Cylinder Assembly	2
10	3691000164	Pin Weld	2
11	7115160950	Capscrew, 0.38"-16NC x 1.12"	5
12	7660162601	Locknut, 0.38"-16NC	5
13	3691000073	Pin Weld	3
14	3020000097	Arm Weld	2
15	7082000017*	Bushing	4
16	7082000018*	Bushing	4
17	7082000016+	Bushing	2
18	7291000010	4-Way Receptacle	1
19	7796000048	Gasket	1
20	7114140528	Screw, 0.25"-20NC x 0.63"	2
21	7660142601	Locknut, 0.25"-20NC	2
22	4330000002	Reflective Tape	2

* included in Arm Weld, P/N 3020000097

+ included in Outer Boom Weld, P/N 3170000275

BALL HITCH MOUNTING PLATE - IRL

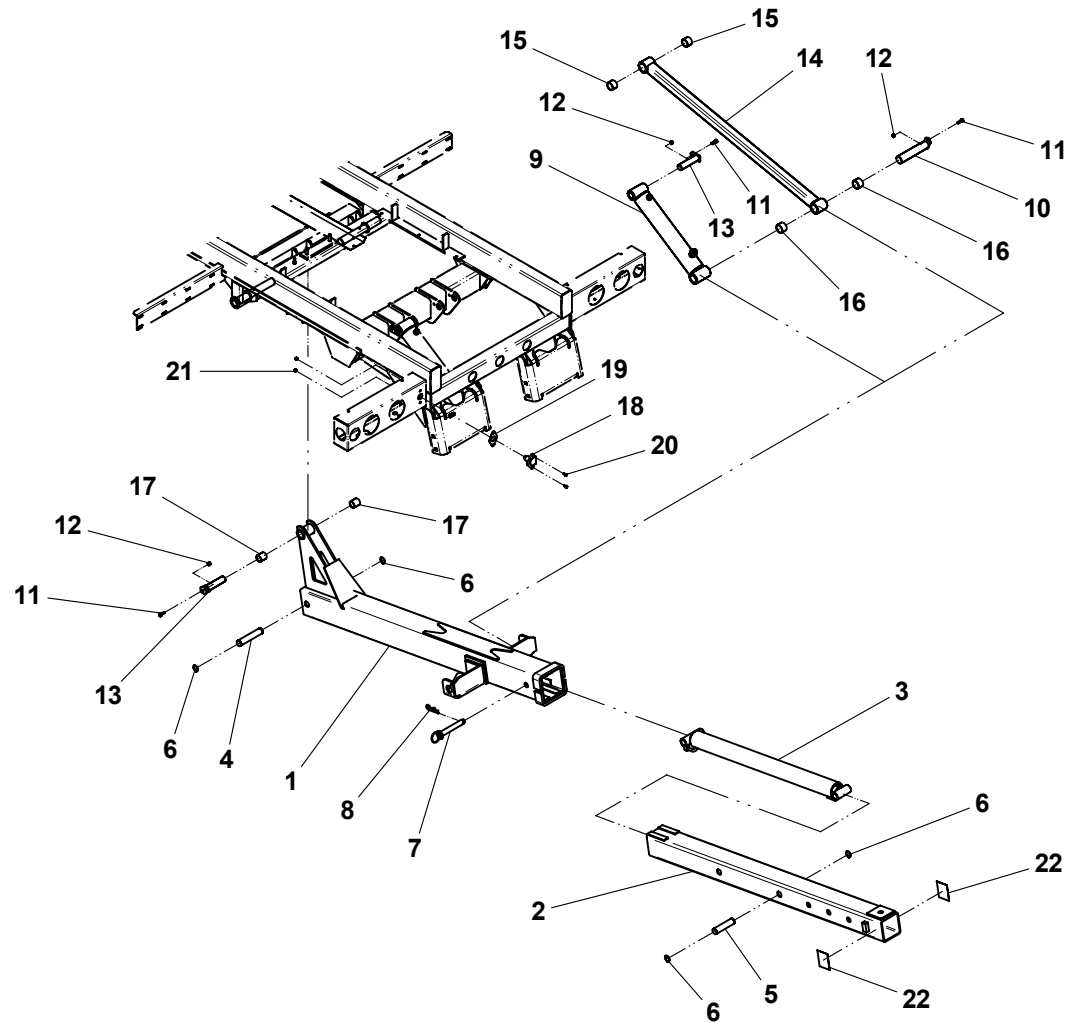

BALL HITCH MOUNTING PLATE - HYDRAULIC EXTEND

ITEM	PART NO.	DESCRIPTION	QTY
1	3170000276	Outer Boom Weld	1
2	3911000062	Inner Boom Weld	1
3	3320000116	Cylinder Assembly	1
4	4691000430	Pin	1
5	4691000429	Pin	1
6	7754000006	Retaining Ring	4
7	3691000073	Pin Weld	1
8	3691000064	Pin Weld	1
9	7115160950	Capscrew, 0.38"-16NC x 1.12"	1
10	7660162601	Locknut, 0.38"-16NC	1
11	3691000097	Pin Weld	1
12	7691000001	Hair Pin	2
13	7082000016*	Bushing	2
14	7291000010	4-Way Receptacle	1
15	7796000048	Gasket	1
16	7114140528	Screw, 0.25"-20NC x 0.63"	2
17	7660142601	Locknut, 0.25"-20NC	2
18	4330000002	Reflective Tape	2

* included in Outer Boom Weld, P/N 3170000276

BALL HITCH MOUNTING PLATE - HYDRAULIC EXTEND

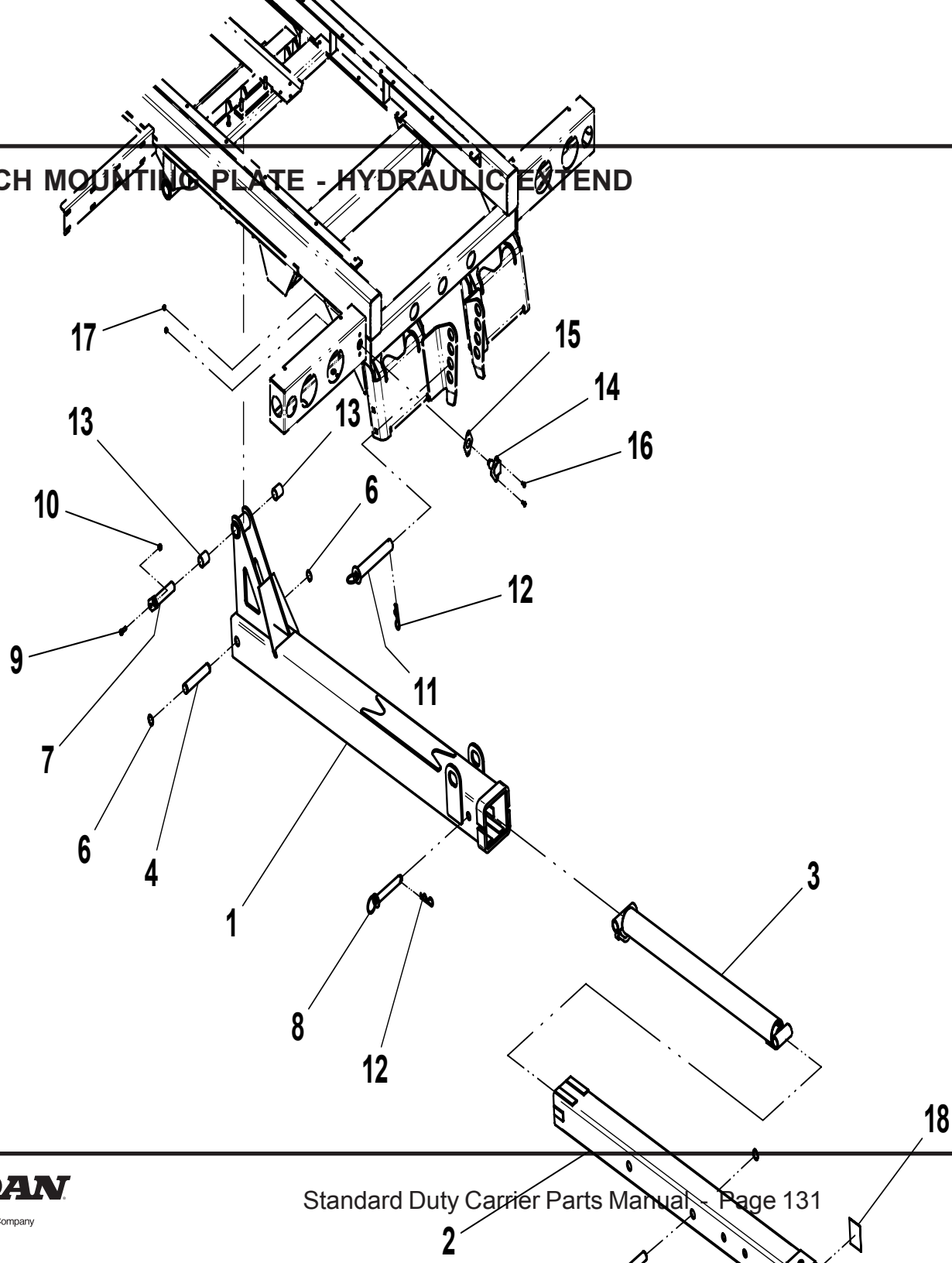

BALL HITCH MOUNTING PLATE - MANUAL EXTEND

ITEM	PART NO.	DESCRIPTION	QTY
1	3170000276	Outer Boom Weld	1
2	3911000062	Inner Boom Weld	1
3	3691000064	Pin Weld	1
4	7691000001	Hair Pin	2
5	3691000073	Pin Weld	1
6	7115160950	Capscrew, 0.38"-16NC x 1.12"	1
7	7660162601	Locknut, 0.38"-16NC	1
8	3691000097	Pin Weld	1
9	7082000016*	Bushing	2
10	7291000010	4-Way Receptacle	1
11	7796000048	Gasket	1
12	7114140528	Screw, 0.25"-20NC x 0.63"	2
13	7660142601	Locknut, 0.25"-20NC	2
14	4330000002	Reflective Tape	2

* included in Outer Boom Weld, P/N 3170000276

BALL HITCH MOUNTING PLATE - MANUAL EXTEND

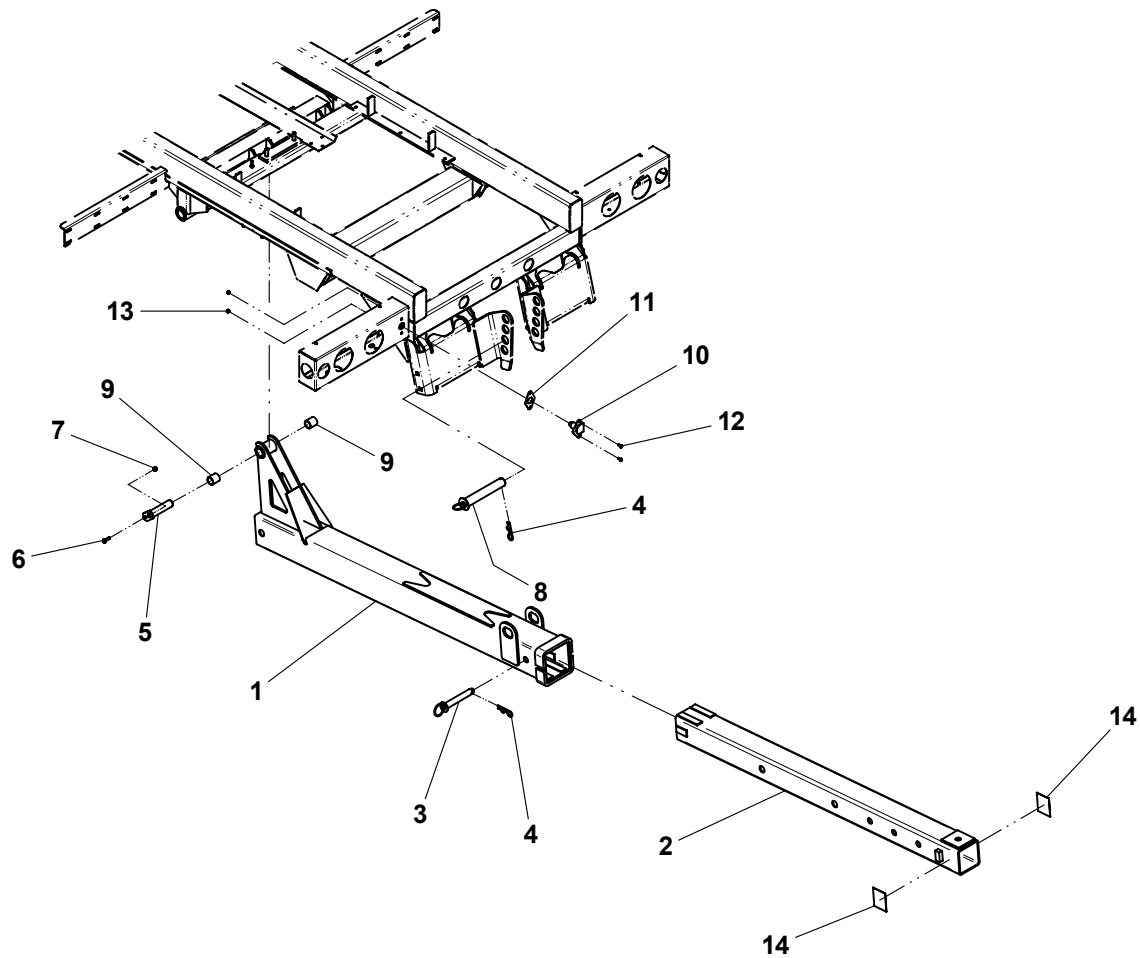

PINTLE HITCH MOUNTING PLATE - IRL

ITEM	PART NO.	DESCRIPTION	QTY
1	3170000275	Outer Boom Weld	1
2	3170000208	Inner Boom Weld	1
3	3320000116	Cylinder Assembly	1
4	4691000430	Pin	1
5	4691000429	Pin	1
6	7754000006	Retaining Ring	4
7	3691000064	Pin Weld	1
8	7691000001	Hair Pin	1
9	3320000114	Cylinder Assembly	1
10	3691000164	Pin Weld	2
11	7115160950	Capscrew, 0.38"-16NC x 1.12"	5
12	7660162601	Locknut, 0.38"-16NC	5
13	3691000073	Pin Weld	3
14	3020000097	Arm Weld	2
15	7082000017*	Bushing	4
16	7082000018*	Bushing	4
17	7082000016+	Bushing	2
18	7291000010	4-Way Receptacle	1
19	7796000048	Gasket	1
20	7114140528	Screw, 0.25"-20NC x 0.63"	2
21	7660142601	Locknut, 0.25"-20NC	2
22	4330000002	Reflective Tape	1
23	4330000645	Reflective Tape, LH	1
24	4330000646	Reflective Tape, RH	1

* included in Arm Weld, P/N 3020000097

+ included in Outer Boom Weld, P/N 3170000275

PINTLE HITCH MOUNTING PLATE - IRL

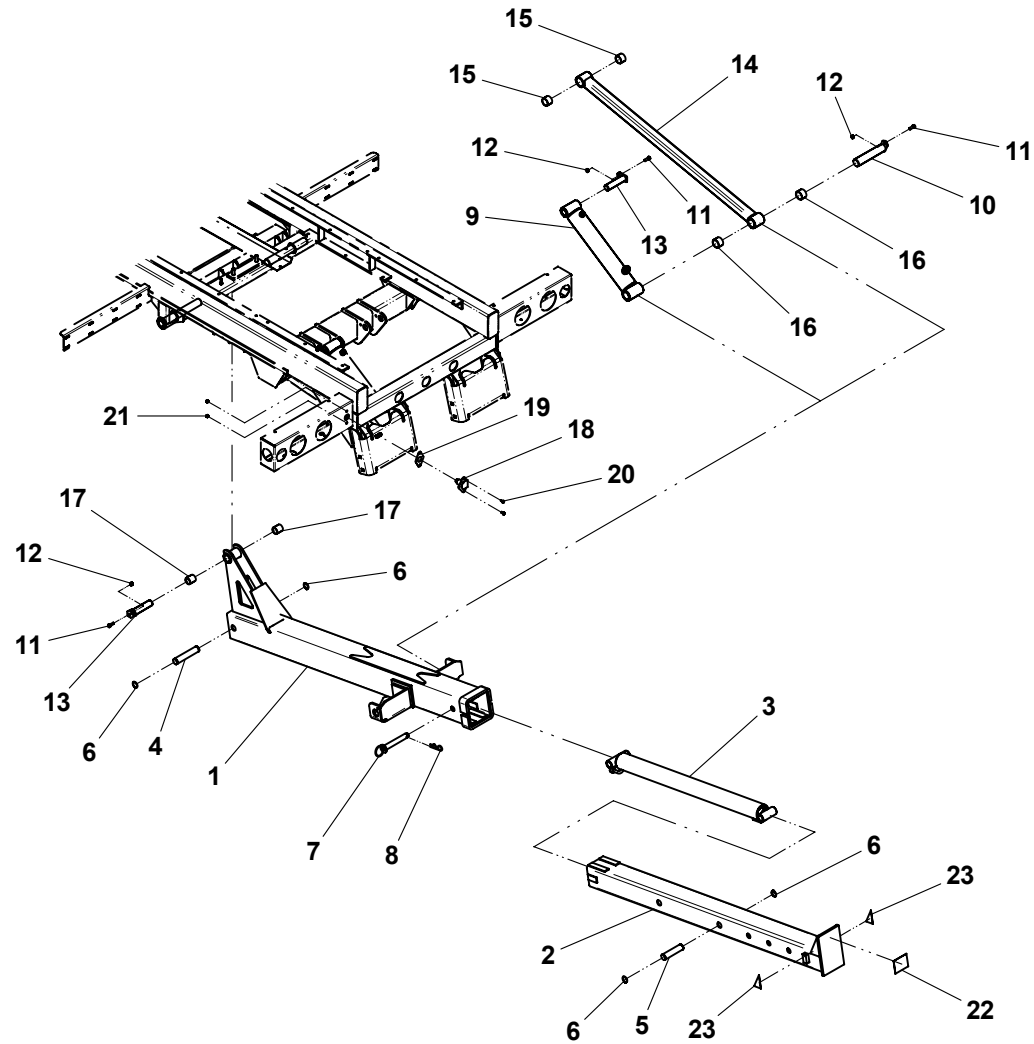

PINTLE HITCH MOUNTING PLATE - HYDRAULIC EXTEND

ITEM	PART NO.	DESCRIPTION	QTY
1	3170000276	Outer Boom Weld	1
2	3170000208	Inner Boom Weld	1
3	3320000116	Cylinder Assembly	1
4	4691000430	Pin	1
5	4691000429	Pin	1
6	7754000006	Retaining Ring	4
7	3691000073	Pin Weld	1
8	3691000064	Pin Weld	1
9	7115160950	Capscrew, 0.38"-16NC x 1.12"	1
10	7660162601	Locknut, 0.38"-16NC	1
11	3691000097	Pin Weld	1
12	7691000001	Hair Pin	2
13	7082000016*	Bushing	2
14	7291000010	4-Way Receptacle	1
15	7796000048	Gasket	1
16	7114140528	Screw, 0.25"-20NC x 0.63"	2
17	7660142601	Locknut, 0.25"-20NC	2
18	4330000002	Reflective Tape	1
19	4330000645	Reflective Tape, LH	1
20	4330000646	Reflective Tape, RH	1

* included in Outer Boom Weld, P/N 3170000276

PINTLE HITCH MOUNTING PLATE - HYDRAULIC EXTEND

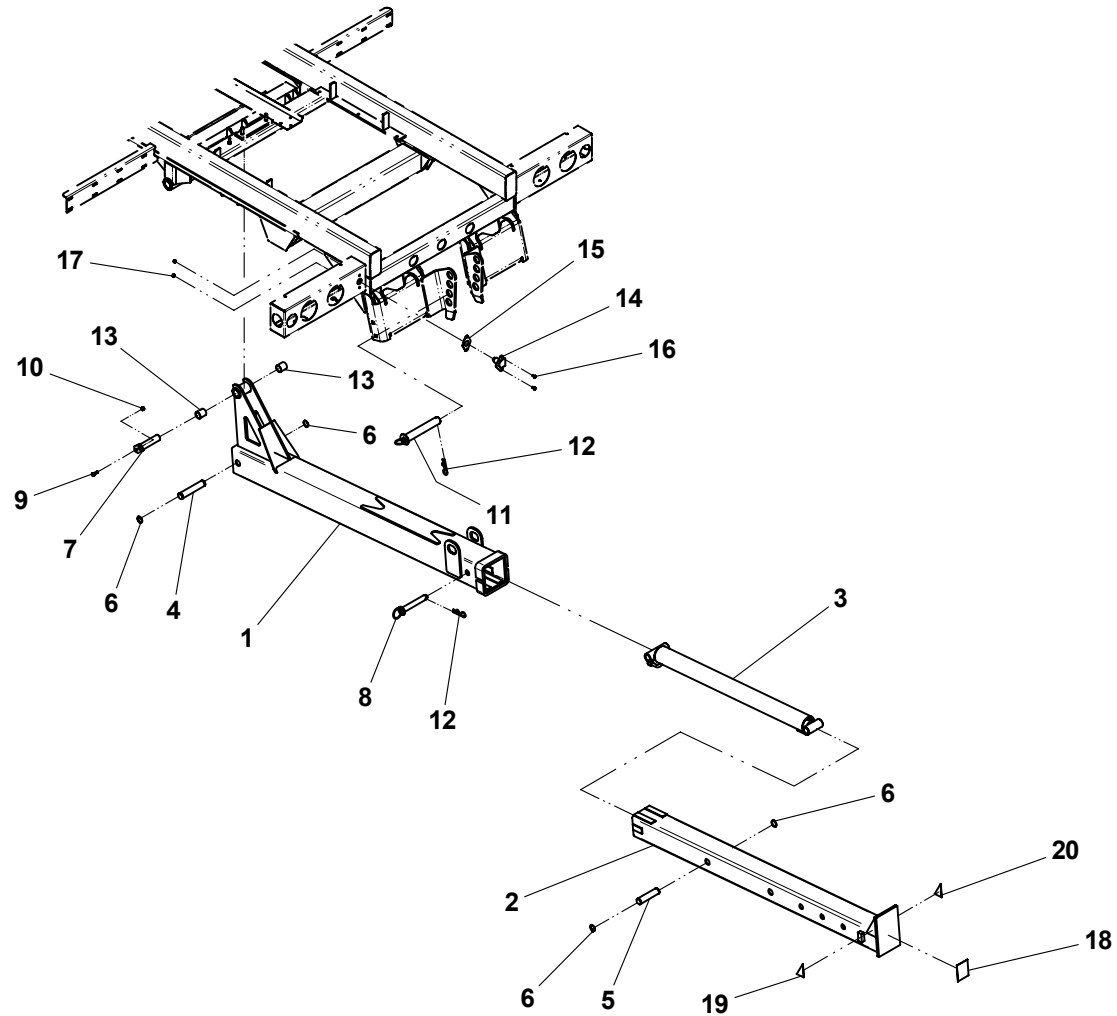

PINTLE HITCH MOUNTING PLATE - MANUAL EXTEND

ITEM	PART NO.	DESCRIPTION	QTY
1	3170000276	Outer Boom Weld	1
2	3170000208	Inner Boom Weld	1
3	3691000064	Pin Weld	1
4	7691000001	Hair Pin	2
5	3691000073	Pin Weld	1
6	7115160950	Capscrew, 0.38"-16NC x 1.12"	1
7	7660162601	Locknut, 0.38"-16NC	1
8	3691000097	Pin Weld	1
9	7082000016*	Bushing	2
10	7291000010	4-Way Receptacle	1
11	7796000048	Gasket	1
12	7114140528	Screw, 0.25"-20NC x 0.63"	2
13	7660142601	Locknut, 0.25"-20NC	2
14	4330000002	Reflective Tape	1
15	4330000645	Reflective Tape, LH	1
16	4330000646	Reflective Tape, RH	1

* included in Outer Boom Weld, P/N 3170000276

PINTLE HITCH MOUNTING PLATE - MANUAL EXTEND

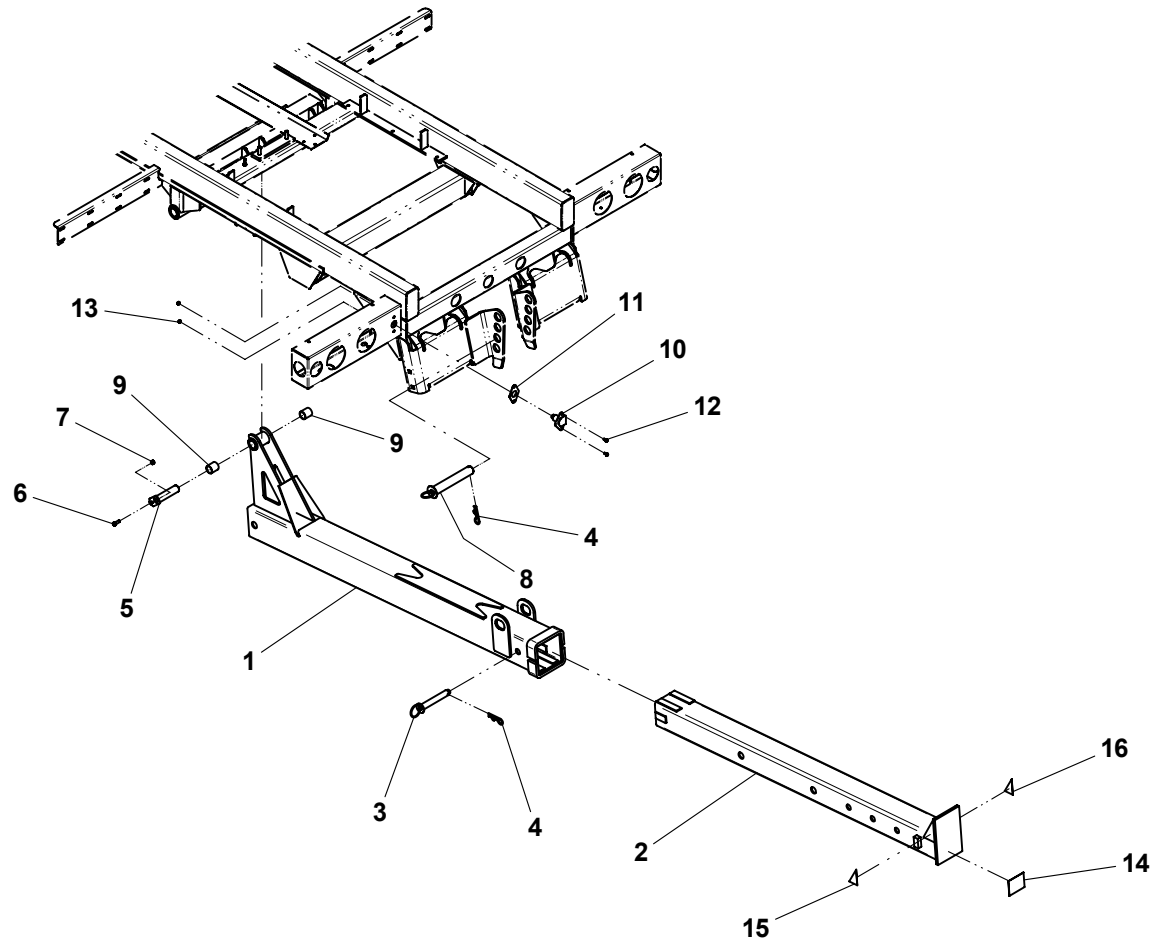

TOWBAR - IRL

ITEM	PART NO.	DESCRIPTION	QTY
1	3170000275	Outer Boom Weld	1
2	3170000048	Inner Boom Weld	1
3	3320000116	Cylinder Assembly	1
4	4691000430	Pin	1
5	4691000429	Pin	1
6	7754000006	Retaining Ring	4
7	7440030000	Grease Fitting	1
8	3320000114	Cylinder Assembly	2
9	3691000164	Pin Weld	2
10	7115160950	Capscrew, 0.38"-16NC x 1.12"	5
11	7660162601	Locknut, 0.38"-16NC	5
12	3691000073	Pin Weld	3
13	3020000097	Arm Weld	2
14	7082000017*	Bushing	4
15	7082000018*	Bushing	4
16	7082000016+	Bushing	2
17	3556000023	Tow Hitch Weld	1
18	4120000008	Capscrew, 1.50"-12NF x 6.38"	1
19	7912000011	Tube Rubber	2
20	7291000010	4-Way Receptacle	1
21	7796000048	Gasket	1
22	7114140528	Screw, 0.25"-20NC x 0.63"	2
23	7660142601	Locknut, .025"-20NC	2
24	7330000419	Reflective Tape	2
25	4330000001	Reflective Tape	1

* included in Arm Weld, P/N 3020000097

+ included in Outer Boom Weld, P/N 3170000275

TOWBAR - IRL

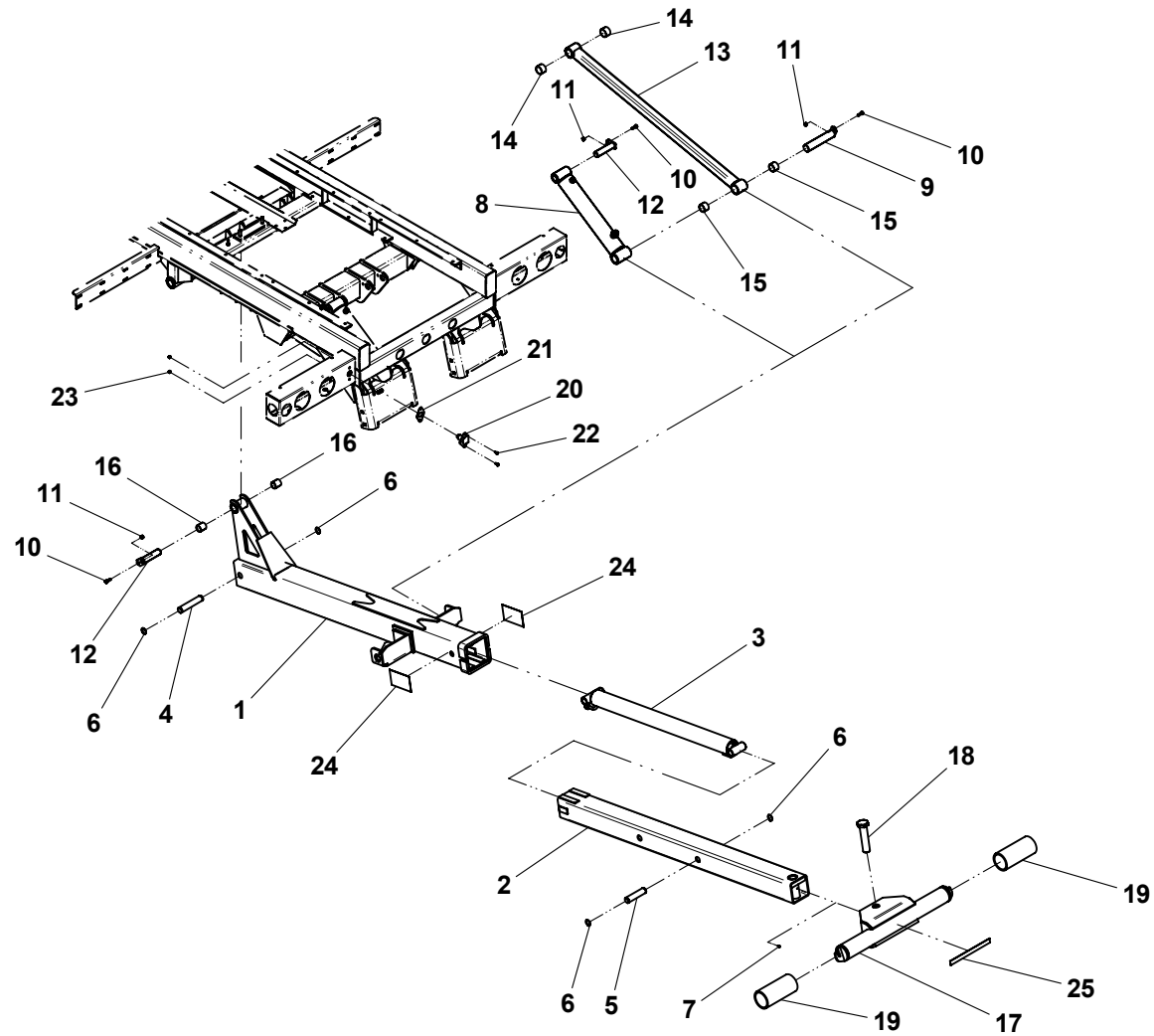

TOWBAR - HYDRAULIC EXTEND

ITEM	PART NO.	DESCRIPTION	QTY
1	3170000276	Outer Boom Weld	1
2	3170000048	Inner Boom Weld	1
3	3320000116	Cylinder Assembly	1
4	4691000430	Pin	1
5	4691000429	Pin	1
6	7754000006	Retaining Ring	4
7	7440030000	Grease Fitting	1
8	3691000073	Pin Weld	1
9	7115160950	Capscrew, 0.38"-16NC x 1.12"	1
10	7660162601	Locknut, 0.38"-16NC	1
11	3691000097	Pin Weld	1
12	7691000001	Hair Pin	1
13	7082000016*	Bushing	2
14	3556000023	Tow Hitch Weld	1
15	4120000008	Capscrew, 1.50"-12NF x 6.38"	1
16	7912000011	Tube Rubber	2
17	7291000010	4-Way Receptacle	1
18	7796000048	Gasket	1
19	7114140528	Screw, 0.25"-20NC x 0.63"	2
20	7660142601	Locknut, 0.25"-20NC	2
21	4330000002	Reflective Tape	2
22	4330000001	Reflective Tape	1

* included in Outer Boom Weld, P/N 3170000276

TOWBAR - HYDRAULIC EXTEND

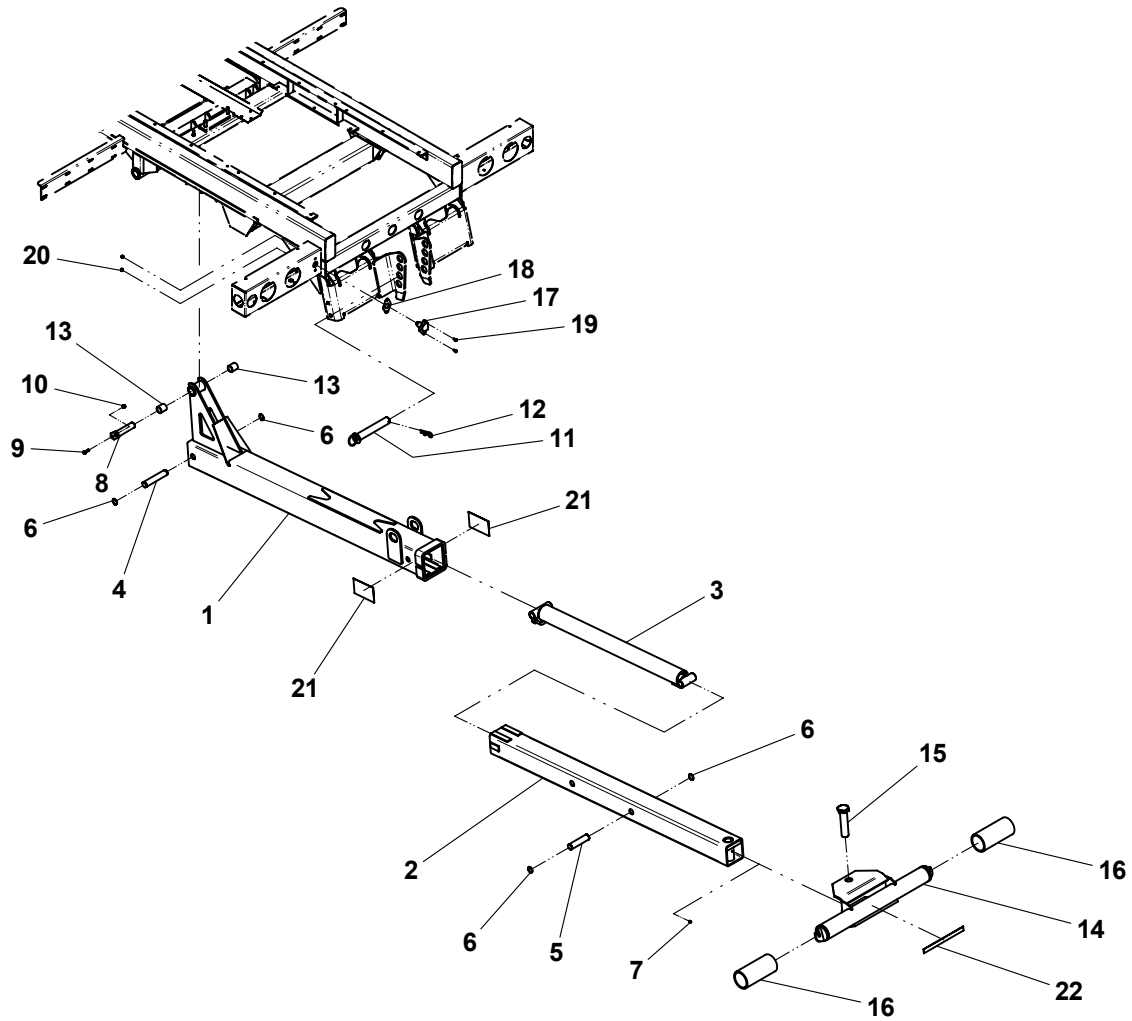

ROLL CYLINDER ASSEMBLY - P/N 3320000112

ITEM	PART NO.	DESCRIPTION	QTY
1	3071000103	Barrel Weld	1
2	4763000204	Rod	1
3	4698000007*	Piston	1
4	7754000003* #	Wear Ring	2
5	7796000063* #	Piston Locking "T" Seal	1
6	7755224609* #	Back-Up Ring	2
7	7755224000* #	"O" Ring	1
8	4553000008^	Head	1
9	7755334000^ #	"O" Ring	1
10	7755334609^ #	Back-Up Ring	1
11	7754000004^ #	Wear Ring	1
12	7796000024^ #	Rod Seal	1
13	7796000008^ #	Rod Wiper Seal	1
14	7754000002 #	Retaining Ring	1
15	7754000026 #	Retaining Ring	1
16	7661000034	Locknut	2

* included in Piston Assembly, P/N 3698000001

^ included in Head Assembly, P/N 3553000011

available only in Service Kit #7577250024

ROLL CYLINDER ASSEMBLY - P/N 3320000112

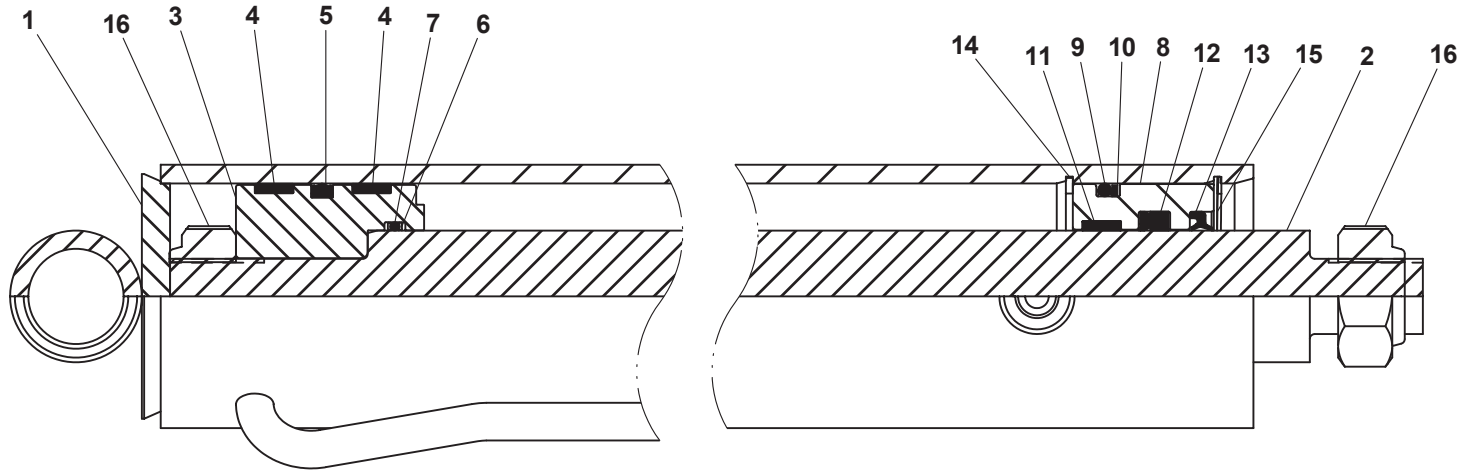

TILT CYLINDER ASSEMBLY (OUTBOARD) - P/N 3320000113

ITEM	PART NO.	DESCRIPTION	QTY
1	3071000104	Barrel Weld	1
2	3763000117	Rod Weld	1
3	4698000015*	Piston	1
4	7754000053* #	Wear Ring	2
5	7796000067* #	Piston Locking "T" Seal	1
6	7755222609* #	Back-Up Ring	2
7	7755222000* #	"O" Ring	1
8	4553000016^	Head	1
9	7755330000^ #	"O" Ring	1
10	7755330609^ #	Back-Up Ring	1
11	7754000054^ #	Wear Ring	1
12	7796000045^ #	Rod Seal	1
13	7796000046^ #	Rod Wiper Seal	1
14	7754000051#	Retaining Ring	2
15	7661000034	Locknut	1
16	7082000016	Bearing	4

* included in Piston Assembly, P/N 3698000006

^ included Head Assembly, P/N 3553000016

available only in Service Kit #7577250206

TILT CYLINDER ASSEMBLY (OUTBOARD) - P/N 3320000113

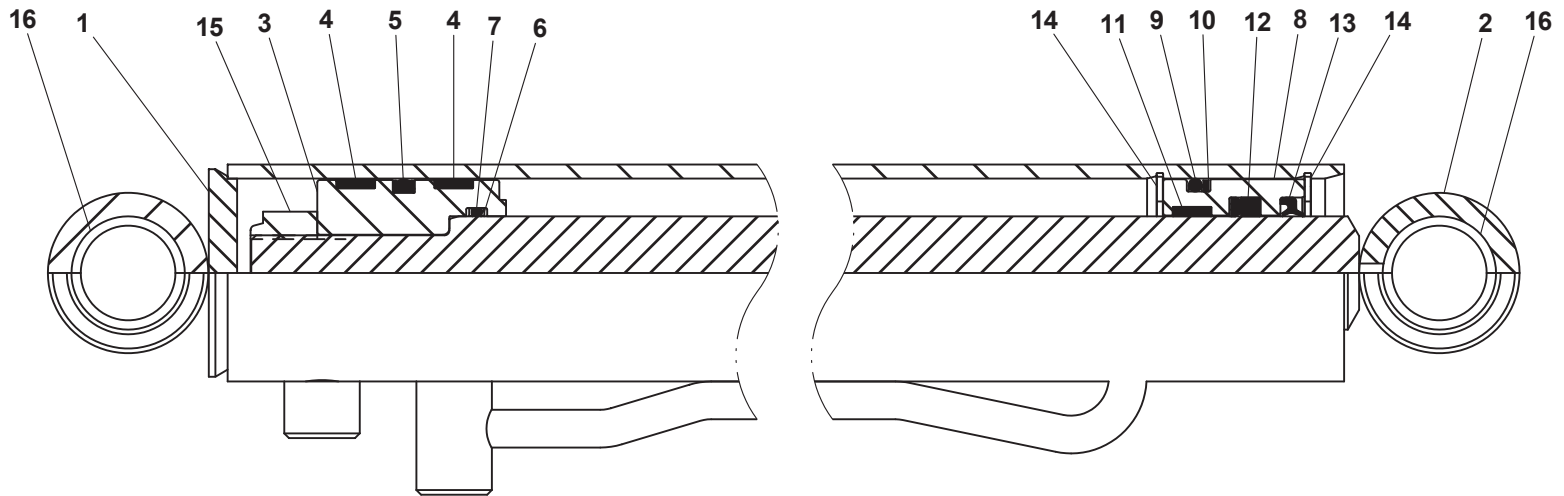

TILT CYLINDER ASSEMBLY (INBOARD) - P/N 3320000120

ITEM	PART NO.	DESCRIPTION	QTY
1	3071000111	Barrel Weld	1
2	3763000123	Rod Weld	1
3	4698000015*	Piston	1
4	7754000053* #	Wear Ring	2
5	7796000067* #	Piston Locking "T" Seal	1
6	7755222609* #	Back-Up Ring	2
7	7755222000* #	"O" Ring	1
8	4553000016^	Head	1
9	7755330000^ #	"O" Ring	1
10	7755330609^ #	Back-Up Ring	1
11	7754000054^ #	Wear Ring	1
12	7796000045^ #	Rod Seal	1
13	7796000046^ #	Rod Wiper Seal	1
14	7754000051#	Retaining Ring	2
15	7661000011	Locknut	1
16	7082000016	Bearing	4

* included in Piston Assembly, P/N 3698000006

^ included in Head Assembly, P/N 3553000016

available only in Service Kit #7577250206

TILT CYLINDER ASSEMBLY (INBOARD) - P/N 3320000120

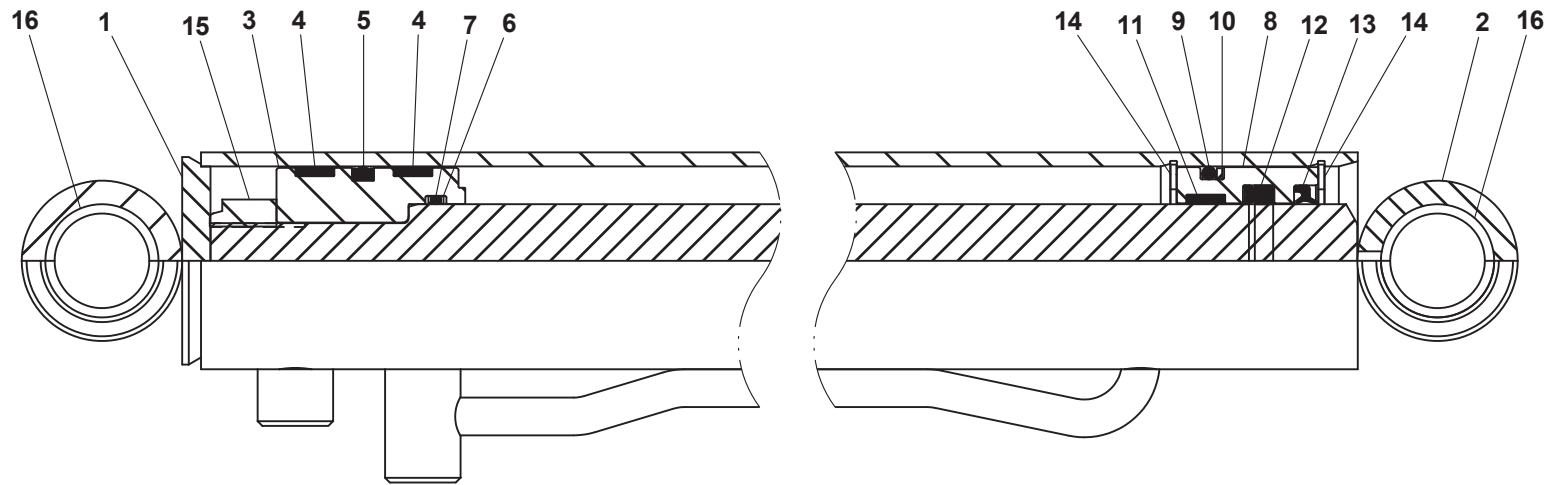

WHEEL LIFT EXTEND CYLINDER ASSEMBLY - P/N 3320000115

ITEM	PART NO.	DESCRIPTION	QTY
1	3071000106	Barrel Weld	1
2	3763000119	Rod Weld	1
3	4698000015*	Piston	1
4	7754000053* #	Wear Ring	2
5	7796000067* #	Piston Locking "T" Seal	1
6	7755222609* #	Back-Up Ring	2
7	7755222000* #	"O" Ring	1
8	4553000016^	Head	1
9	7755330000^ #	"O" Ring	1
10	7755330609^ #	Back-Up Ring	1
11	7754000054^ #	Wear Ring	1
12	7796000045^ #	Rod Seal	1
13	7796000046^ #	Rod Wiper Seal	1
14	7754000051#	Retaining Ring	2
15	7661000034	Locknut	1

* included in Piston Assembly, P/N 3698000006

^ included in Head Assembly, P/N 3553000016

available only in Service Kit #7577250206

WHEEL LIFT EXTEND CYLINDER ASSEMBLY - P/N 3320000115

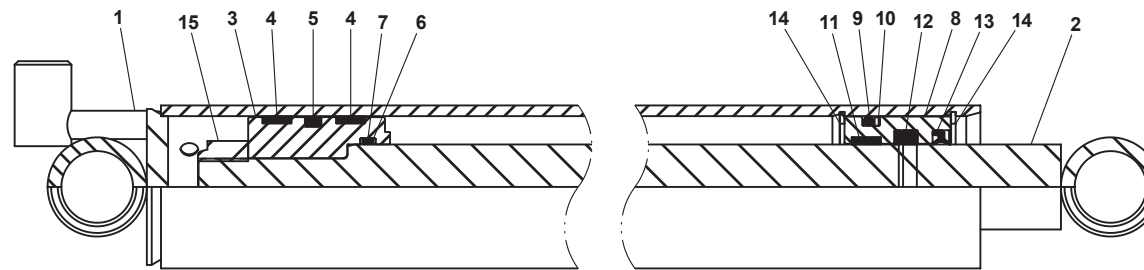

IRL CYLINDER ASSEMBLY - P/N 3320000114 & 3320000134

ITEM	PART NO.	DESCRIPTION	QTY
1	3071000105	Barrel Weld (auto grids)	1
	3017000131	Barrel Weld (auto grids)	
2	3763000118	Rod Weld (manual grids)	1
	3763000139	Rod Weld (auto grids)	
3	4698000007*	Piston	1
4	7754000003* #	Wear Ring	2
5	7796000063* #	Piston Locking "T" Seal	1
6	7755224609* #	Back-Up Ring	2
7	7755224000* #	"O" Ring	1
8	4553000008^	Head	1
9	7755334000^ #	"O" Ring	1
10	7755334609^ #	Back-Up Ring	1
11	7754000004^ #	Wear Ring	1
12	7796000024^ #	Rod Seal	1
13	7796000008^ #	Rod Wiper Seal	1
14	7754000002 #	Retaining Ring	1
15	7754000026 #	Retaining Ring	1
16	7661000034	Locknut	1
17	7082000016	Bearing	2
18	7082000018	Bearing	2

* included in Piston Assembly, P/N 3698000001

^ included in Head Assembly, P/N 3553000011

available only in Service Kit #7577250024

IRL CYLINDER ASSEMBLY - P/N 3320000114 & 3320000134

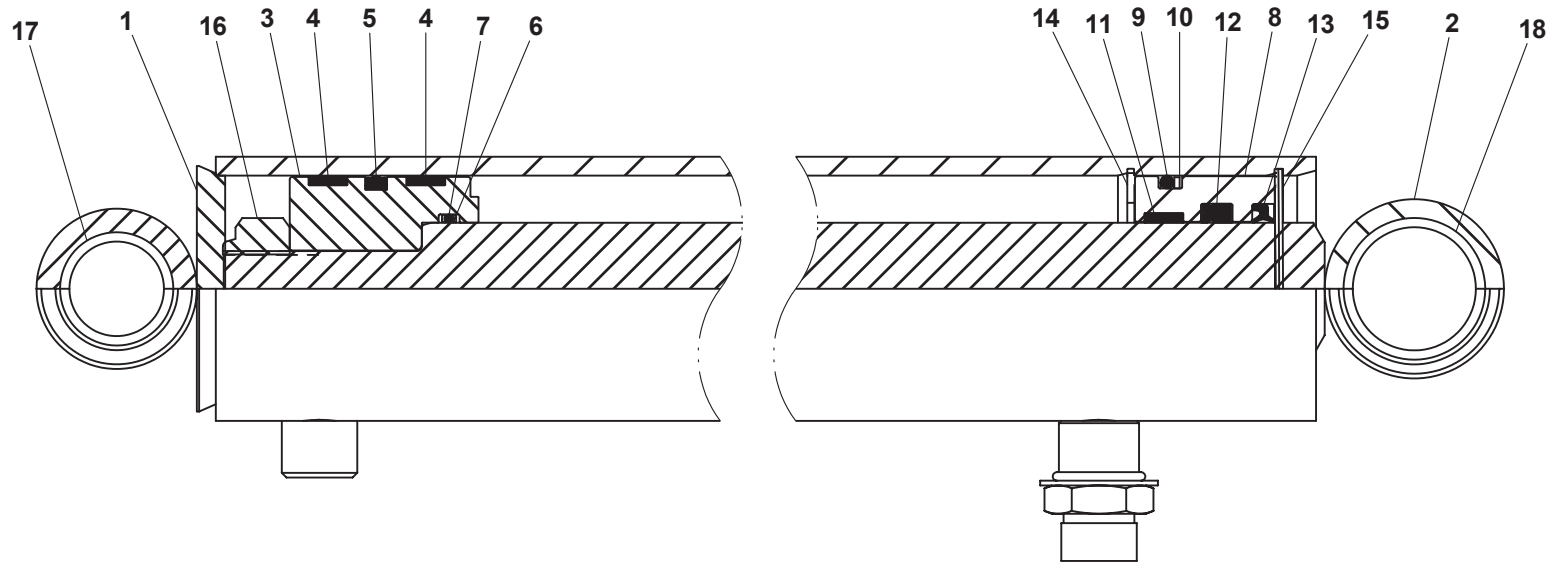

ZOD CYLINDER ASSEMBLY - P/N 3320000118, 3320000135 & 7330000157

ITEM	PART NO.	DESCRIPTION	QTY
1	3071000109	Barrel Weld (manual grids)	1
	3071000139	Barrel Weld (auto grids, std frame))	
	3071000103	Barrel Weld (auto grids, high frame)	
2	3763000122	Rod Weld (manual grid)	1
	3763000140	Rod Weld (auto grids, std frame)	
	3763000170	Rod Weld (auto grids, high frame)	
3	4698000015*	Piston	1
4	7754000053* #	Wear Ring	2
5	7796000067* #	Piston Locking "T" Seal	1
6	7755224609* #	Back-Up Ring	2
7	7755224000* #	"O" Ring	1
8	4553000016^	Head	1
9	7755330000^ #	"O" Ring	1
10	7755330609^ #	Back-Up Ring	1
11	7754000054^ #	Wear Ring	1
12	7796000045^ #	Rod Seal	1
13	7796000046^ #	Rod Wiper Seal	1
14	7754000051 #	Retaining Ring	2
15	7661000034	Locknut	1
16	7082000016	Bearing	4

* include in Piston Assembly, P/N 3698000006

^ included in Head Assembly, P/N 3553000016

available only in Service Kit #7577250206

ZOD CYLINDER ASSEMBLY - P/N 3320000118, 3320000135 & 3320000157

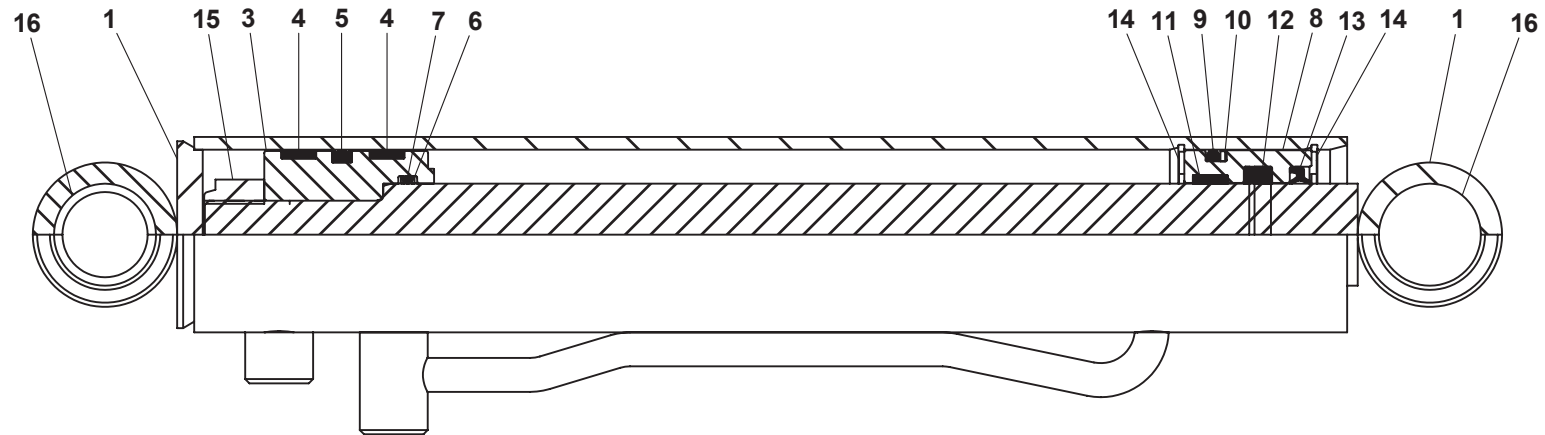

STABILIZER CYLINDER ASSEMBLY - P/N 3320000119

ITEM	PART NO.	DESCRIPTION	QTY
1	3071000110	Barrel Weld	1
2	3763000118	Rod Weld	1
3	4698000007*	Piston	1
4	7754000003* #	Wear Ring	2
5	7796000063* #	Piston Locking "T" Seal	1
6	7755224609* #	Back-Up Ring	2
7	7755224000* #	"O" Ring	1
8	4553000008^	Head	1
9	7755334000^ #	"O" Ring	1
10	7755334609^ #	Back-Up Ring	1
11	7754000004^ #	Wear Ring	1
12	7796000024^ #	Rod Seal	1
13	7796000008^ #	Rod Wiper Seal	1
14	7754000002 #	Retaining Ring	1
15	7754000026 #	Retaining Ring	1
16	7661000034	Locknut	1
17	7082000016	Bearing	2
18	7082000018	Bearing	2

* included in Piston Assembly, P/N 3698000001

^ included in Head Assembly, P/N 3553000011

available only in Service Kit #7577250024

STABILIZER CYLINDER ASSEMBLY - P/N 3320000119

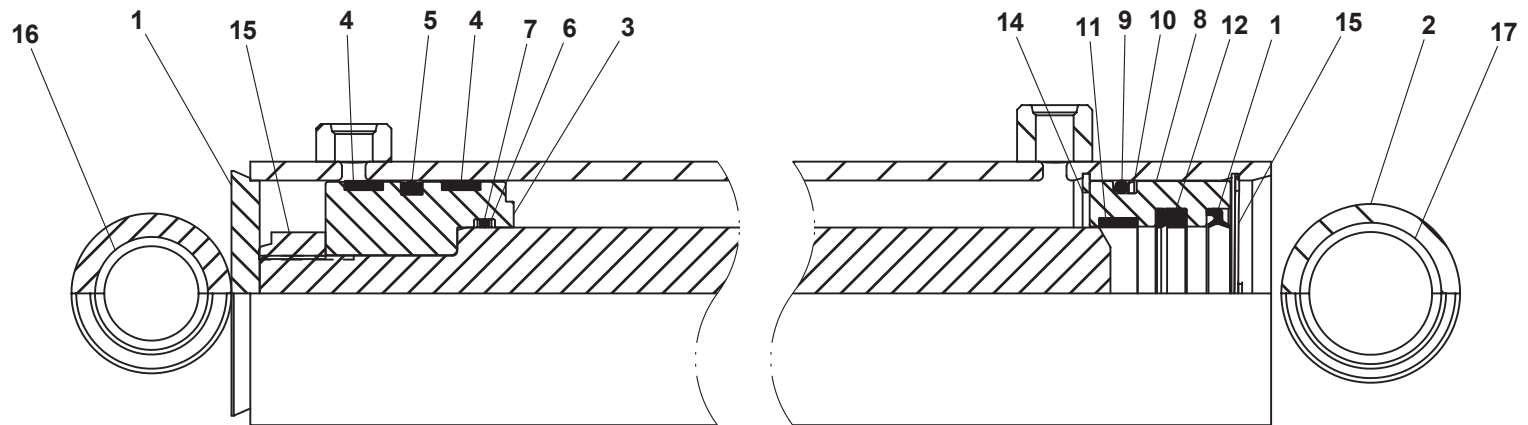

TOW OPTION HYDRAULIC EXTEND CYLINDER ASSEMBLY - P/N 3320000116 AND P/N 3320000117

ITEM	PART NO.	DESCRIPTION	QTY
1	3071000107	Barrel Weld (IRL tow option extend)	1
	3071000108	Barrel Weld (stabilizer tow option extend)	
2	3763000120	Rod Weld (IRL tow option extend)	1
	3763000121	Rod Weld (stabilizer tow option extend)	
3	4698000007*	Piston	1
4	7754000003* #	Wear Ring	2
5	7796000063* #	Piston Locking "T" Seal	1
6	7755224609* #	Back-Up Ring	2
7	7755224000* #	"O" Ring	1
8	4553000008^	Head	1
9	7755334000^ #	"O" Ring	1
10	7755334609^ #	Back-Up Ring	1
11	7754000004^ #	Wear Ring	1
12	7796000024^ #	Rod Seal	1
13	7796000008^ #	Rod Wiper Seal	1
14	7754000002 #	Retaining Ring	1
15	7754000026 #	Retaining Ring	1
16	7661000034	Locknut	1

* included in Piston Assembly, P/N 3698000001

^ included in Head Assembly, P/N 3553000011

available only in Service Kit #7577250024

TOW OPTION HYDRAULIC EXTEND CYLINDER ASSEMBLY - P/N 3320000116 AND P/N 3320000117

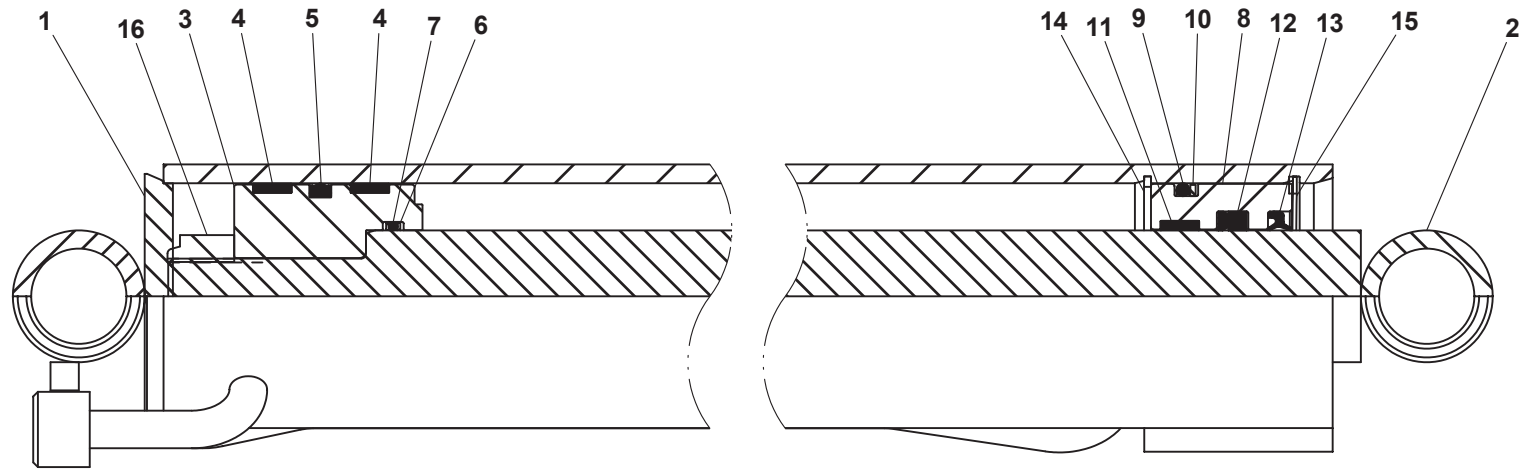

LIGHTBARS

ITEM	PART NO.	DESCRIPTION	QTY
1	7590000306	Lightbar, Amber Halogen	1
	7590000311	Lightbar, Amber LED	
2	4178000402	Bracket (standard mount)	2
	4178000437	Bracket (high mount)	
3	7115180850	Capscrew, 0.50"-13NC x 1.00"	2
4	7950180252	Flatwasher, 0.50" ID	2
5	7950180000	Lockwasher, 0.50" ID	2

LIGHTBARS

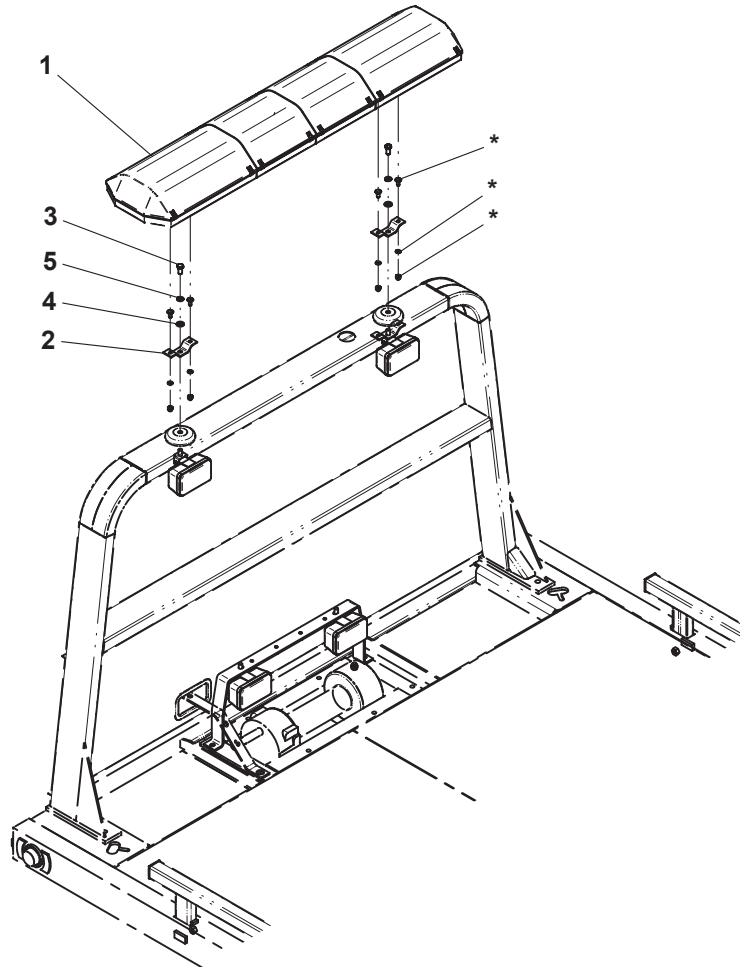

* included in Lightbar

SWITCH PANELS

ITEM	PART NO.	DESCRIPTION	QTY
1	4178000403	Bracket - 1 Function Switch Panel	1
2	4178000427	Bracket - 2 Function Switch Panel	1
3	7870000083	Switch	1
4	7870000113	Switch Panel - 3 Function, Mini In-Dash	1
5	7870000100	Switch Panel - 3 Function, In-Dash	1
6	7870000106	Switch Panel - 5 Function, In-Dash	1
7	7870000076	Switch Panel - 3 Function, In-Dash for IHC4300/4400	1
8	7870000053	Switch Panel - 3 Function, Under Dash	1
9	7870000063	Switch Panel - 5 Function, Under Dash	1
10	7870000089	Switch Panel - 5 Function	1

SWITCH PANELS

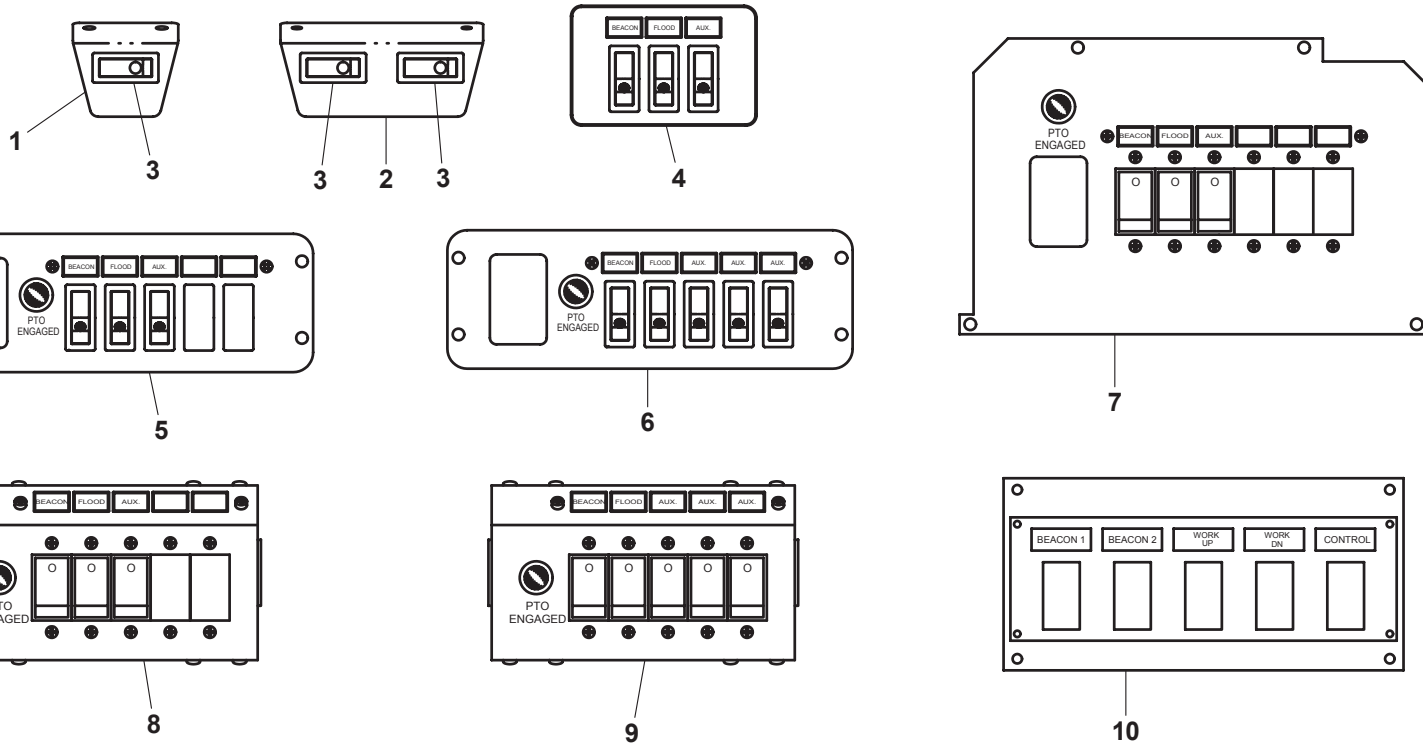

WORK LIGHTS

ITEM	PART NO.	DESCRIPTION	QTY
1	7590000223	Worklight	4
2	4178000402	Bracket	2
3	7790151253	Screw, 0.31"-18NC x 0.75	4
4	7493000003	Grommet	2
5	7552000222	Harness - Headboard Worklights	1
6	4178000423	Bracket	1
7	7280000011	Clip	6
8	7552000166	Harness - Winch Worklights	1
9	7590000185	Worklight	2

WORK LIGHTS

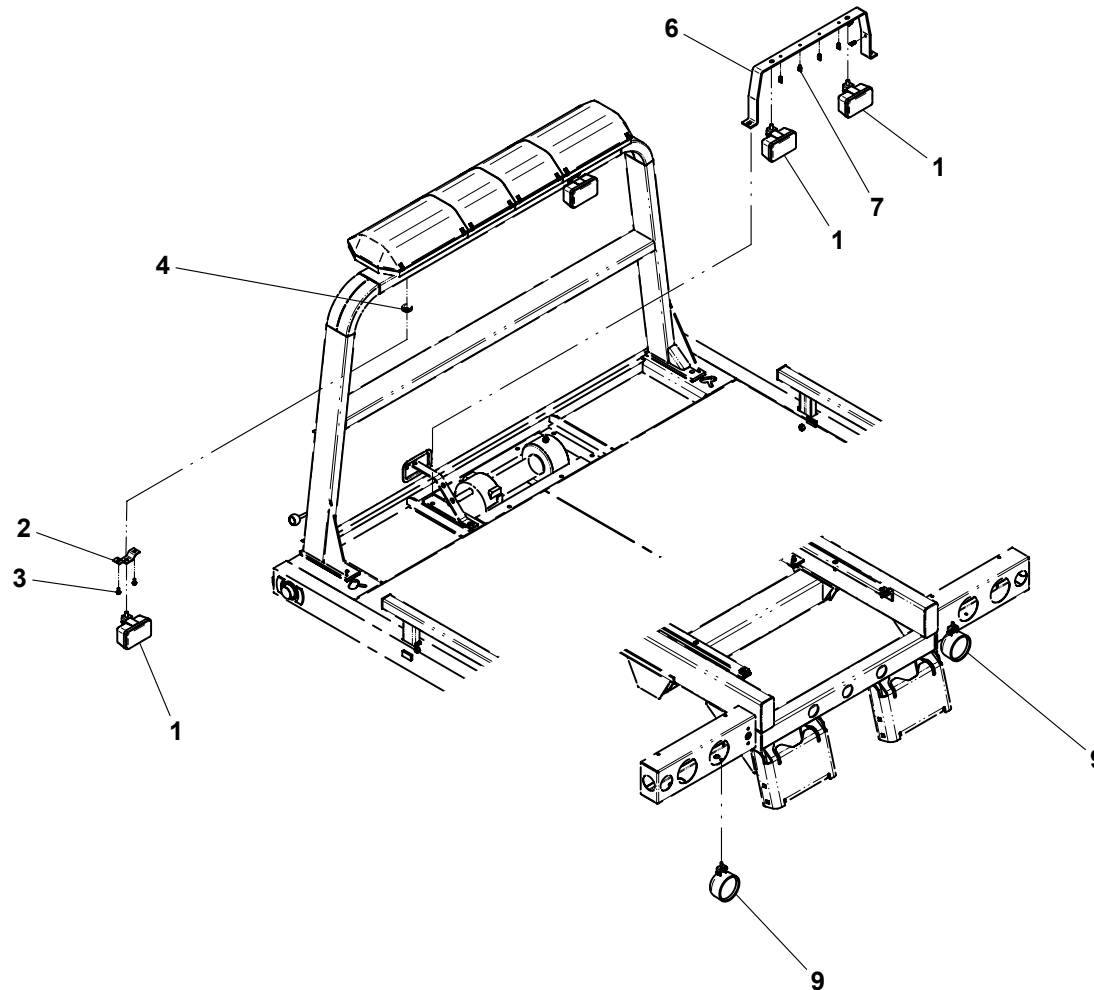

Items #5 & #8, Harness, not shown

BOLT-ON D-RINGS

ITEM	PART NO.	DESCRIPTION	QTY
1	3556000019	D-Ring	1
2	7115182050	Capscrew, 0.50"-13NC x 2.50"	2
3	7950180161	Flatwasher, 0.50" ID (aluminum decks only)	2
4	7660182601	Locknut, 0.50"-13NC	2

BOLT-ON D-RINGS

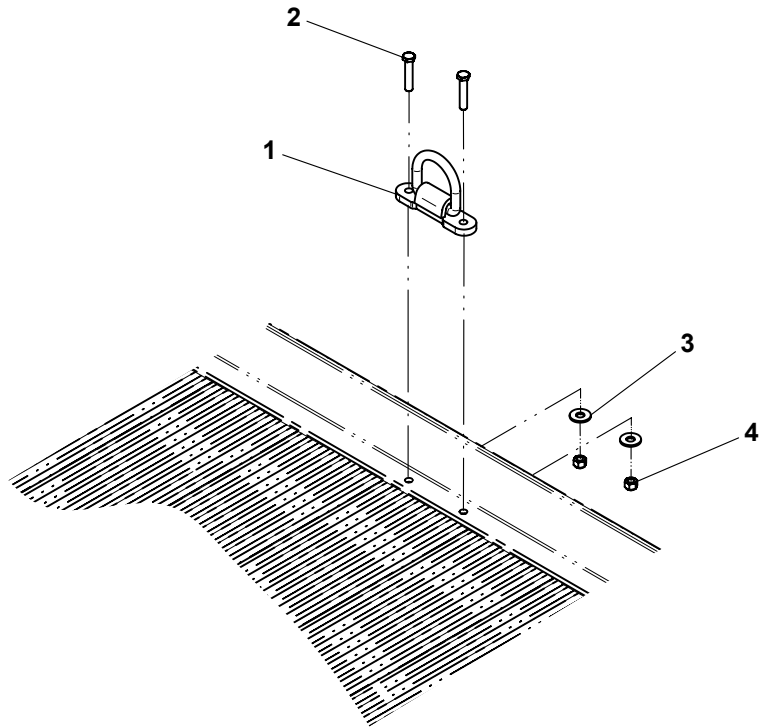

ALUMINUM DECK

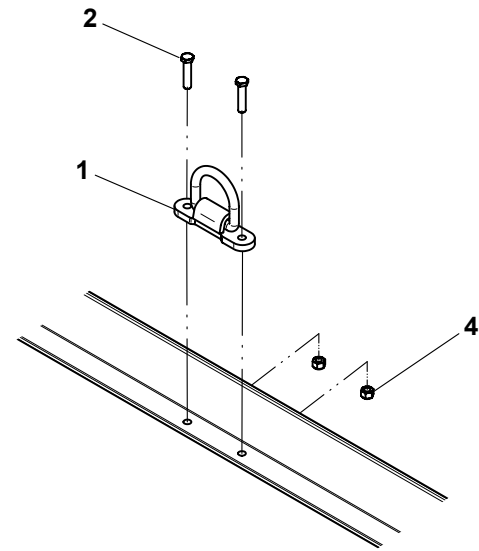

STEEL DECK

REMOTE CONTROL OPERATION(S)

ITEM	PART NO.	DESCRIPTION	QTY	ITEM	PART NO.	DESCRIPTION	QTY
1	7005000003	Linear Actuator 12V	1*	18	7660142601	Locknut, 0.25"-20NC	2
2	4706005361	Plate	2			(1, 2 & 3 remote operations)	
3	7115150864	Carriage Bolt, 0.31"-18NC x 1.00"	4		7660142601	Locknut, 0.25"-20NC	5
4	7950150161	Flatwasher, 0.31" ID	4			(4 & 5 remote operation)	
5	7660152601	Locknut, 0.31"-18NC	4	19	4706005396	Plate (4 & 5 remote operation)	1
6	4178000664	Bracket	1*	20	7114080618	Capscrew, #8-32NC x 0.75"	4
7	4178000665	Bracket	1*			(4 & 5 remote operation)	
8	4691000141	Pin (3, 4 & 5 section control valve)	1	21	7660102604	Locknut, #10-24NC	4
	4691000373	Pin (6 section control valve)				(4 & 5 remote operations)	
	4691000374	Pin (7 section control valve)		22	9295310018#	Transmitter (1 remote operation)	1
9	4211000001	Bushing	4*		9295310020#	Transmitter (2 remote operations)	
10	7950220141	Flatwasher, 0.75" ID	4		9295310019#	Transmitter (3 remote operations)	
11	7754000009	Retaining Ring	2		9295310025#	Transmitter (4 & 5 remote operations)	
12	7295000097	Controller (1 remote operation)	1		9295310026#	Transmitter (6 & 7 remote operations)	
	7295000078	Controller (2 remote operations)		23	7330000612	Decal - Controller Functions	1
	7295000075	Controller (3 remote operations)				(4 & 5 remote operations)	
	7295000099	Controller (4 remote operations)		24	7115150864	Carriage Bolt, 0.31"-18NC x 1.00"	2*
	7295000095	Controller (5 remote operations)		25	7660152601	Locknut, 0.31"-18NC	2*
	7295000102	Controller (6 remote operations)					
	7295000103	Controller (7 remote operations)					
13	4706003650	Plate	1				
14	7104100613	Screw, #10-32NF x 0.34"	4				
15	7661000007	Wellnut, #10-32NF	4				
16	7115140650	Capscrew, 0.25"-20NC x 0.75"	2			(1, 2 & 3 remote operations)	
	7115140650	Capscrew, 0.25"-20NC x 0.75"	5			(4 & 5 remote operations)	
17	7950140141	Flatwasher, 0.25" ID	2			(1, 2 & 3 remote operations)	
	7950140141	Flatwasher, 0.25" ID	5			(4 & 5 remote operations)	

* quantities are for 1 remote operation, adjust quantities for 2, 3, 4 & 5 remote operations

included with Controller, item #12

REMOTE CONTROL OPERATION(S)

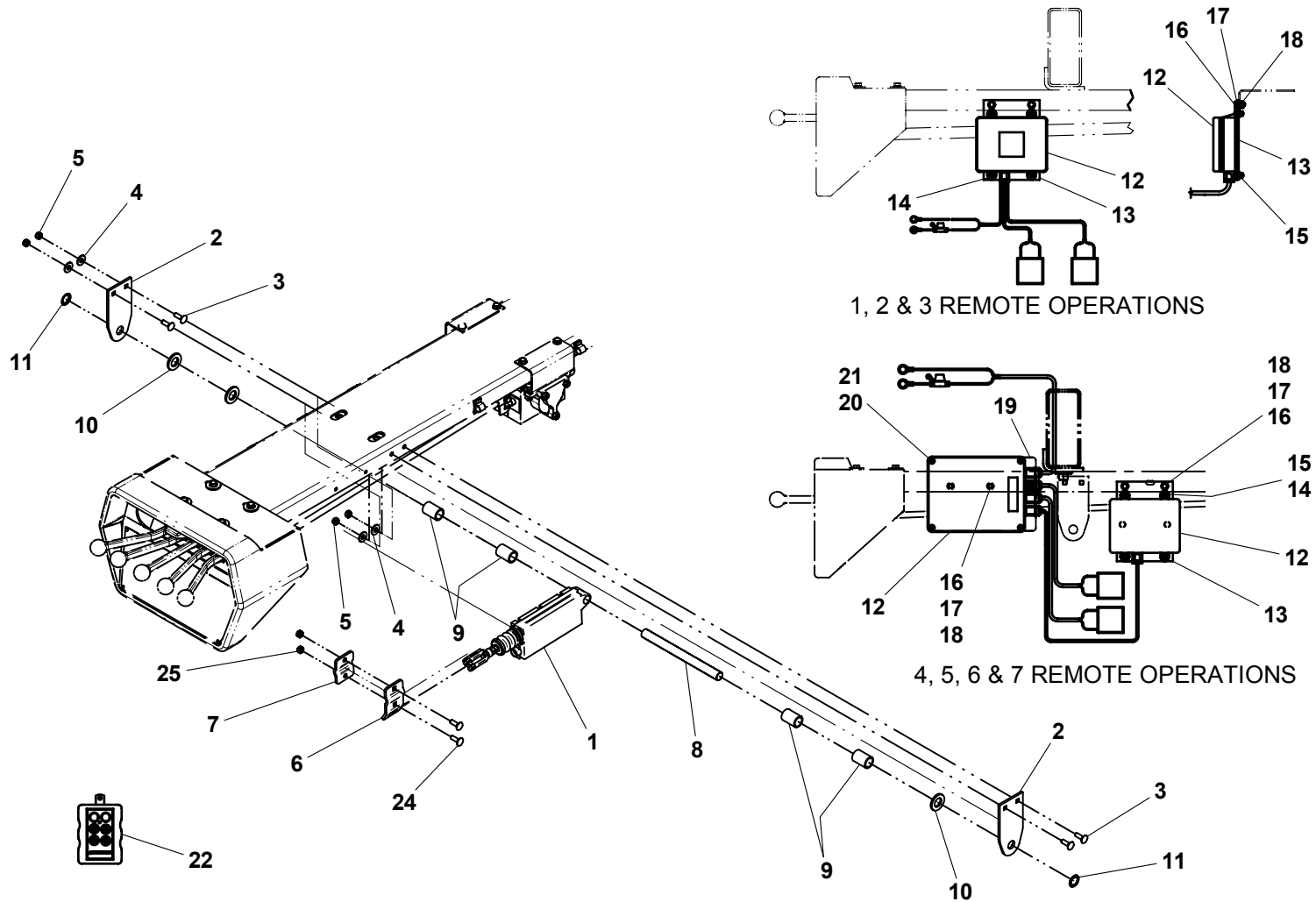

One Remote Operaton shown

Item #23, Decal- Controller Functions, not shown

REMOTE THROTTLE CONTROL

ITEM	PART NO.	DESCRIPTION	QTY
1	7346000208	Pressure Switch	1
2	7552000241	Harness	1
3	7443000427*	Check Valve	1
4	7445060643*	Adapter	1

* also available in Check Valve w/ Adapter, P/N 7443000428.

REMOTE THROTTLE CONTROL

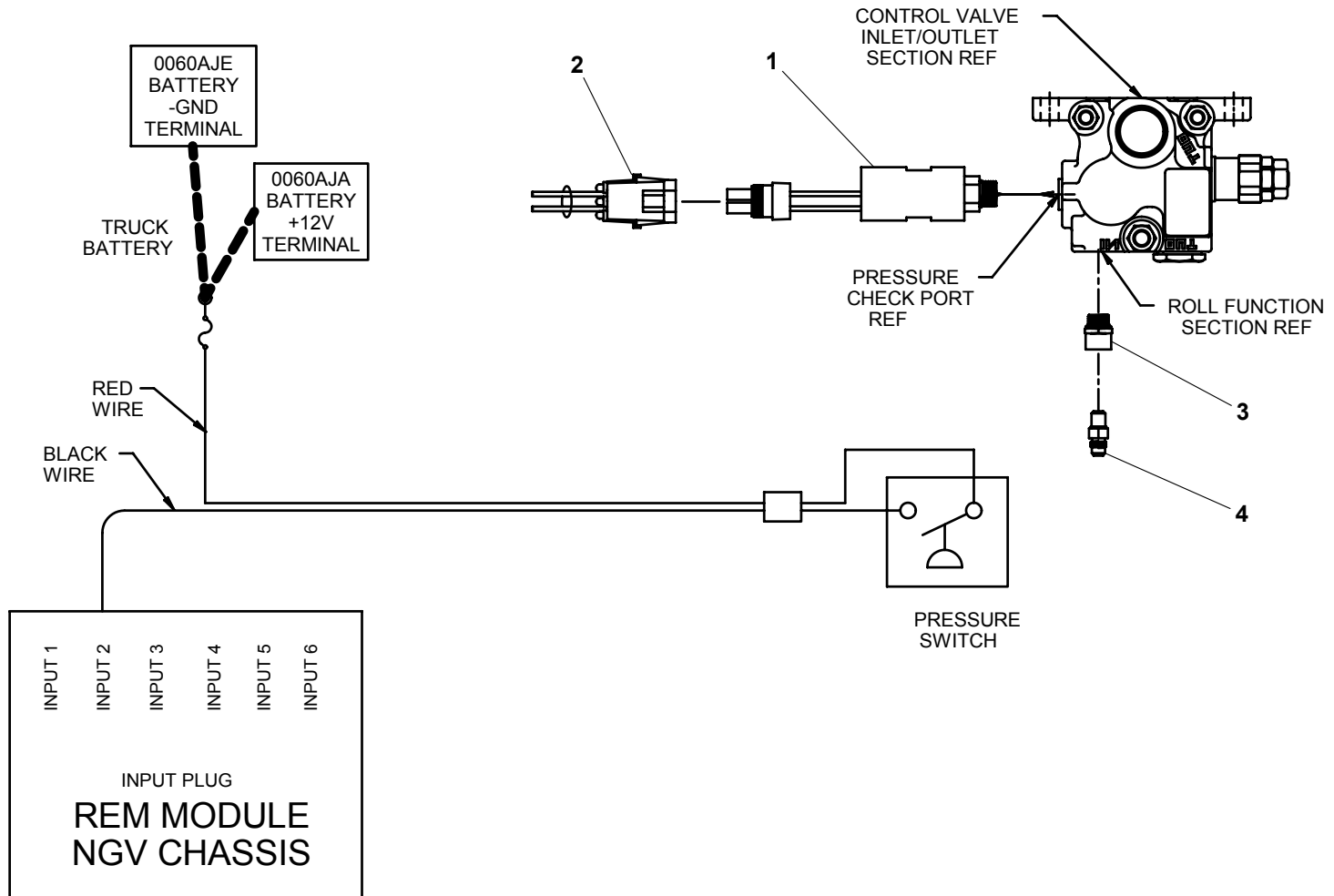

GLAD HANDS AND 7- WAY CONNECTOR

ITEM	PART NO.	DESCRIPTION	QTY
1	4178000666*	Bracket	1
2	7115181464*	Carriage Bolt, 0.50"-13NC x 1.75"	2
3	7660182601*	Locknut, 0.50"-13NC	2
4	7346000055+	Electrical Receptacle 7-way Connect	1
5	7346000078+	Electrical Boot	1
6	7111150813+	Capscrew, 0.31"-18NC x 1.00"	2
7	7660152601+	Locknut, 0.31"-18NC	2
8	7346000132	Electrical Adapter 7 to 4 way	1
9	7346000157	Electrical Adapter 7 to 6 way	1
10	7312000015^	Gladhand	1
11	7312000016^	Gladhand	1
12	7446502518^	Bulkhead Fitting	2
13	7446382506^	Connector	2
14	7577000145^	Seal Kit Gladhand	1
15	7565000014^	Airline Tubing	50 ft
16	7312000013^	Union	2

* also available in Bracket Install Glad Hands and 7 Way, P/N 2178000037

+ also available in Electrical Install 7 Way Connector, P/N 2346000008

^ also available in Glad Hand Install, P/N 2002000016

GLAD HANDS AND 7-WAY CONNECTOR

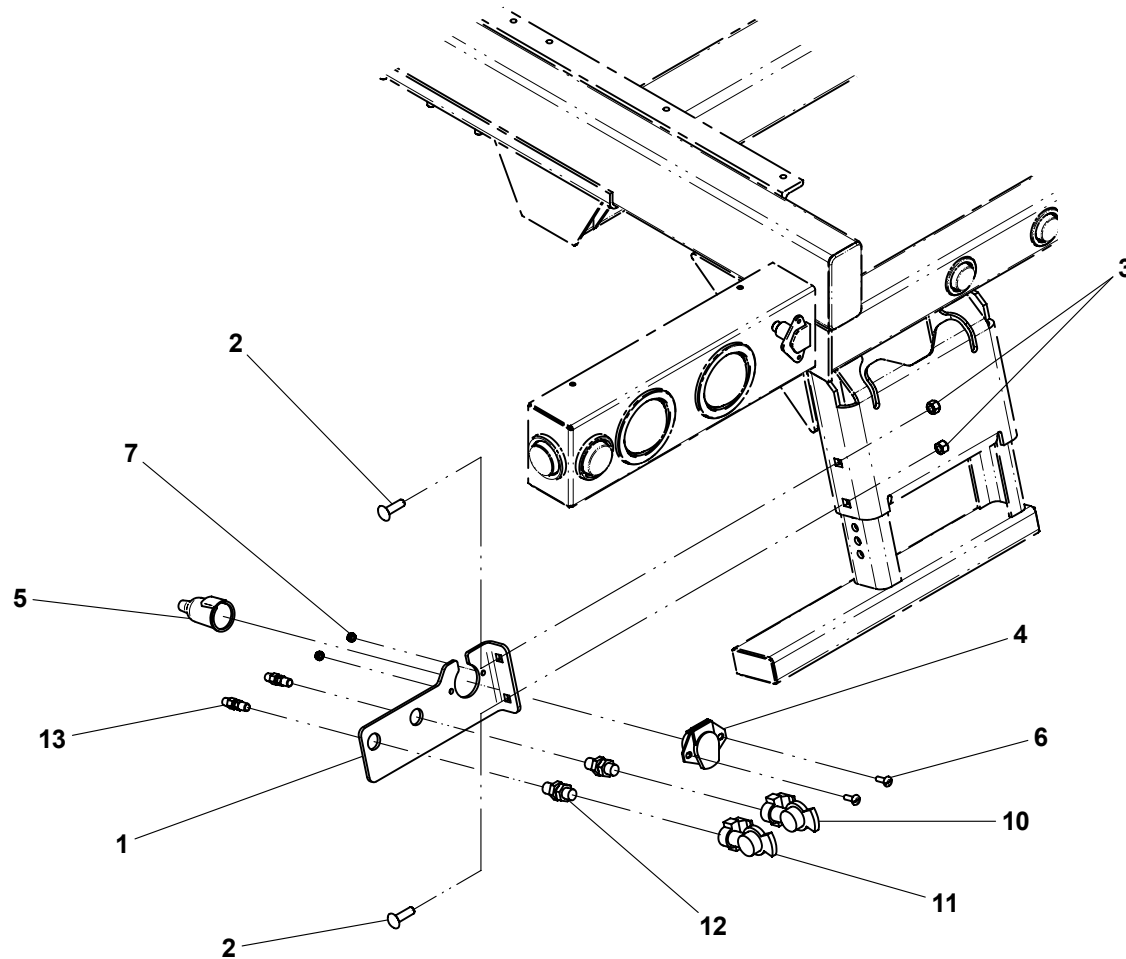

Item #8 Electrical Adapter 7 to 4 Way not shown
Item #9 Electrical Adapter 7 to 6 Way not shown
Item #14, Seal Kit Gladhand; #15, Airline Tubing; & #16, Union not shown

AIR SUPPLY DISCONNECT

ITEM	PART NO.	DESCRIPTION	QTY
1	7312000017	Coupling	1
2	7445080853	Elbow	1
3	7446502518	Bulkhead Fitting	1
4	7443000111	Elbow	1
5	7446382506	Connector	1
6	7565000014	Airline Tubing	32 ft
7	7935000120	Air Valve	1
8	7443000154	Bushing	1
9	7443000156	Nipple	1
10	7894000031	Cable Tie	6
11	7443000366	Fitting	1

AIR SUPPLY DISCONNECT

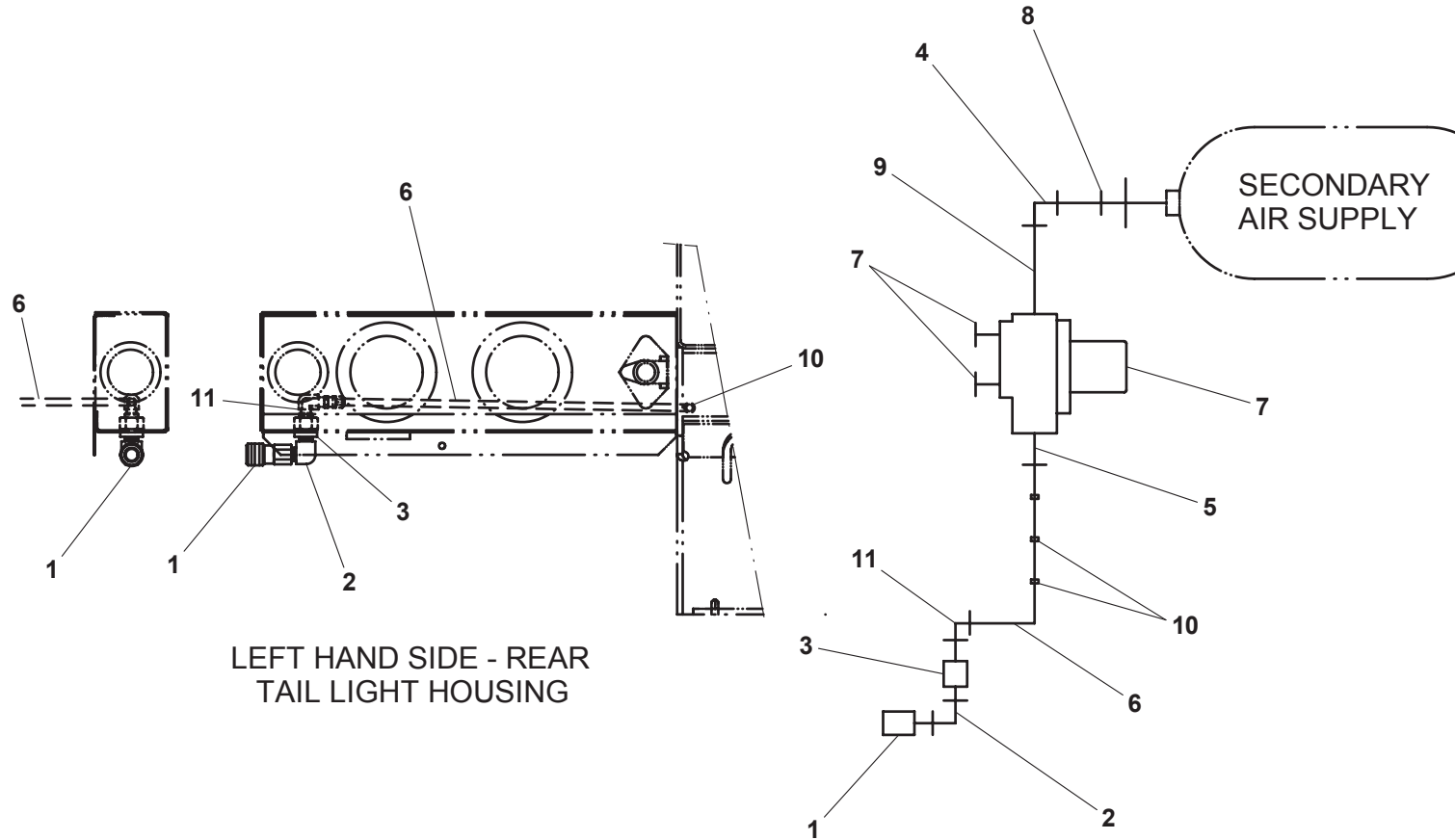

JUMP START KIT

ITEM	PART NO.	DESCRIPTION	QTY
1	7002000386	Jump Start Plug (IHC & Other)	1
	7002000385	Jump Start Plug (Ford & Chevy)	
2	4178000372	Bracket (Ford & Other)	1
	4178000202	Bracket (Chevy)	
3	4178000203	Bracket (Chevy)	1
	4706003210	Plate (Other)	
4	7110140605	Capscrew, 0.25"-20NC x 0.75" (Ford, Chevy & Other)	1
5	7950140161	Flatwasher, 0.25" ID (Ford & Other)	1
	7950140161	Flatwasher, 0.25" ID (IHC)	2
	7950140161	Flatwasher, 0.25" ID (Chevy)	3
6	7660142600	Locknut, 0.25"-20NC (Ford, Chevy & Other)	1
	7660142600	Locknut, 0.25"-20NC (IHC)	2
7	7115151064	Carriage Bolt, 0.31"-18NC x 1.25" (Other)	2
8	7950150161	Flatwasher, 0.31" ID (Other)	2
9	7660152601	Locknut, 0.31"-18NC (Other)	2
10	7115141450	Capscrew, 0.25"-20NC x 1.75" (IHC)	1
11	7115141650	CapScrew, 0.25"-20NC x 2.00" (IHC)	1
12	7660140000	Hex Nut, 0.25"-20NC (IHC)	1
	7660140000	Hex Nut, 0.25"-20NC (Chevy)	2
13	7111140850	Capscrew, 0.25"-20NC x 1.00" (Chevy)	2
14	7115181050	Capscrew, 0.50"-13NC x 1.25" (Chevy)	1
15	7950180153	Flatwasher, 0.50" ID (Chevy)	1
16	7660180000	Hex Nut, 0.50"-13NC (Chevy)	1

JUMP START KIT

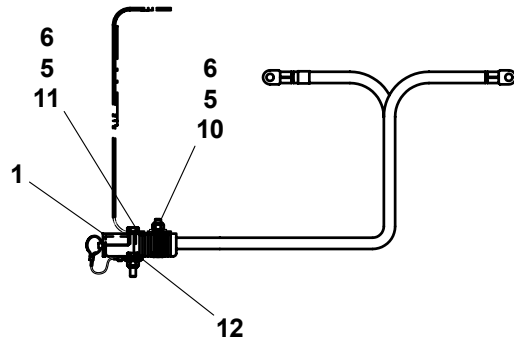

IHC FRONT BUMPER

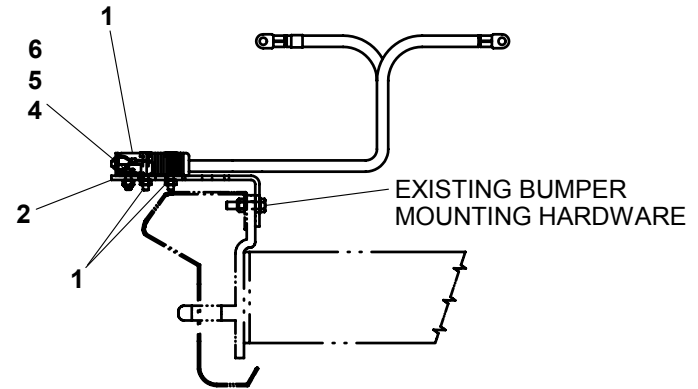

FORD FRONT BUMPER

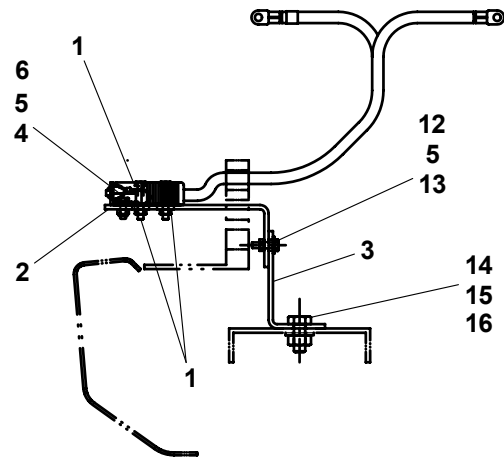

CHEVY FRONT BUMPER

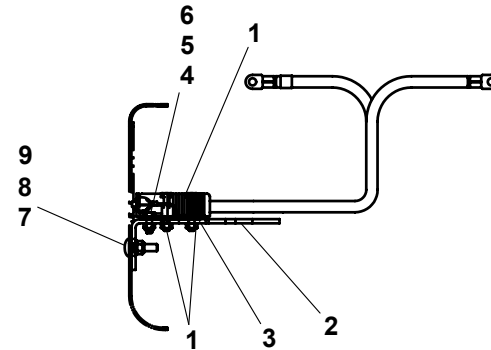

ALL OTHER FRONT BUMPERS

FOLDING DECK LADDER

ITEM	PART NO.	DESCRIPTION	QTY
1	3178000321	Bracket Weld	1
2	3002000009	Ladder Top Weld	1
3	3002000008	Ladder Bottom Weld	1
4	7114181418	Capscrew, 0.50"-13NC x 1.75"	4
5	7950180141	Flatwasher, 0.50" ID	12
6	7660182601	Locknut, 0.50"-13NC	4
7	7115180606	Shoulder Bolt, 0.50"-13NC x 0.75"	2
8	7950160141	Flatwasher, 0.38" ID	2
9	7660162601	Locknut, 0.38"-16NC	2

FOLDING DECK LADDER

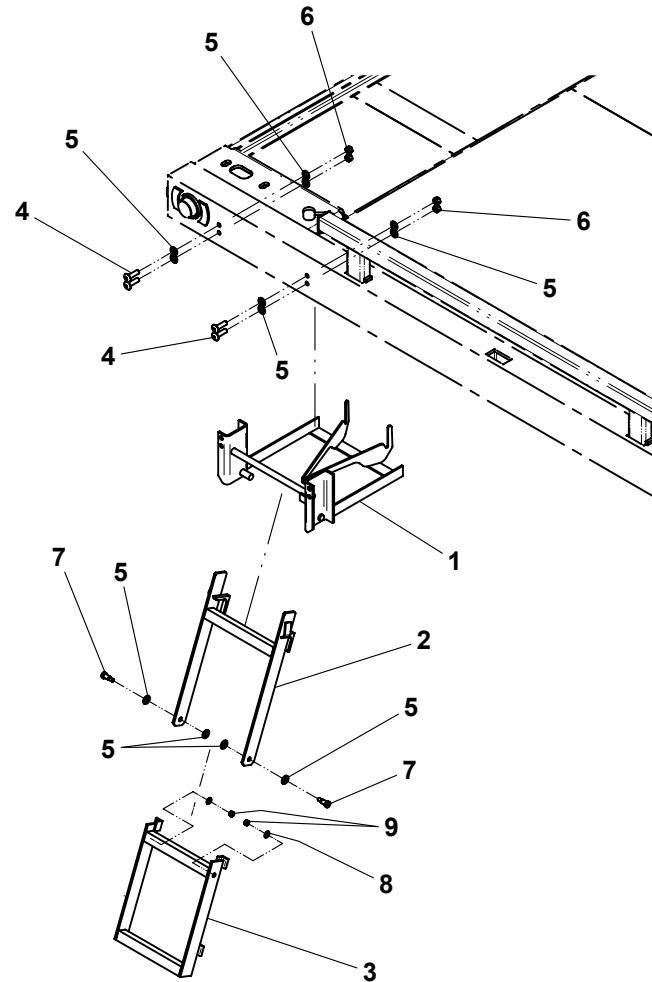

CHAIN AND STRAPS

ITEM	PART NO.	DESCRIPTION	QTY
1	7262000022*	Winch V-Chain	1
2	7262000056*	Front Tie-Down Chain	2
3	7894000019*	Rear Tie-Down Strap	2
4	7894000020*	Rear Tie Down Ratchet	2
5	7262000040	Wheel Lift Chain	2
6	7894000034	Wheel Lift Tire Strap	2
7	7262000010	Towbar Chain	2
8	7894000058^	Tire Strap (hydraulic grid)	1
9	7894000059^	Choker (hydraulic grid)	1
10	7894000028^	Ratchet (hydraulic grid)	1
11	7561000024^	Forged Hook (hydraulic grid)	1
12	7115181664	Carriage Bolt, 0.50"-13NC x 2.00"	2
13	7660180001	Nut, 0.50"-13NC	2
14	7660182601	Locknut, 0.50"-13NC	2

* also available in Deck Chain / Tie-Down Kit, P/N 7577000208

^ also available in Auto Grid Wheel Lift Tie-Down Kit, P/N 7577000376

CHAIN AND STRAPS

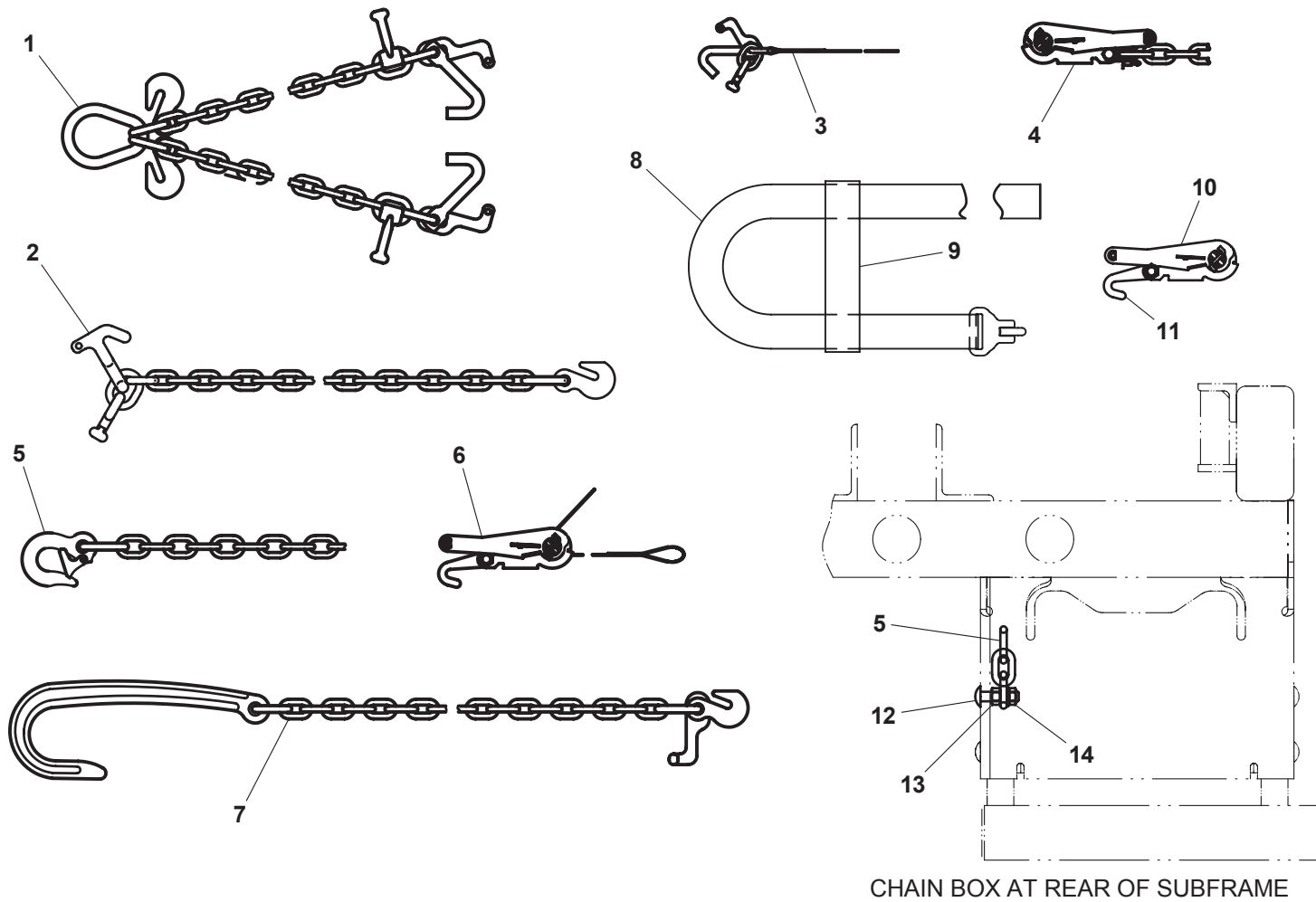

DECALS

ITEM	PART NO.	DESCRIPTION	QTY
1	7330000167	Serial Number Tag	1
2	7330000338	Subframe / Patent Tag	1
3	7330000502	Decal - Slide Pad / Pivot Joint	1
4	7330000159	STAR Placard	1
5	7330000275	Decal - Operator's Pre-Checklist	1
6	7330000242	Decal - Free Spool (bolt-on headboard)	1
	7330000495	Decal - Free Spool (stationary headboard)	1
7	7330000478	Decal - Lubrication Chart	1
8	7330000012	Decal - Winch	1
9	7330000433	Jerr-Dan Nameplate	3
10	7330000143	Decal - Made In The USA	1
11	7330000044	Decal - Align Arrow, Red	2
	7330000045	Decal - Align Arrow, White	2
12	7330000272	Decal - Oil Level	1
13	7330000330	Decal - Cable Track	1
14	7330000139	Decal - Checklist Reminder	1
15	7330000684	Decal - Safety	1
16	7330000683	Decal - Safety	2
17	7330000060	Decal - Wheel Lift Hitch	1
18	7330000036	Secure Vehicle	2
19	7330000391	Decal - Tow Boom Configuration	1
20	7330000274	Decal - Overloading Tow Option	1
21	7330000599	Decal - Pinch Point	3
22	9330740009	Decal Kit - Muncie PTO	1
23	7759000004	Pop Rivet	12

DECALS

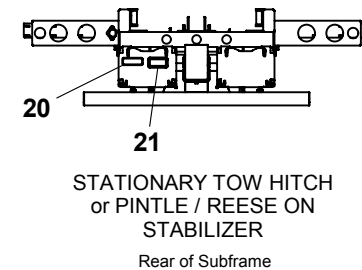
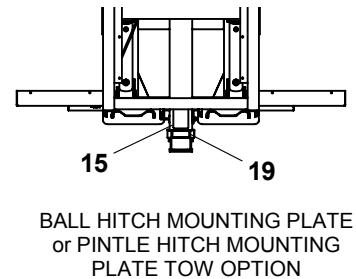
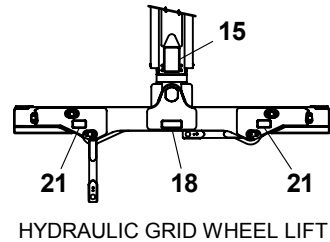
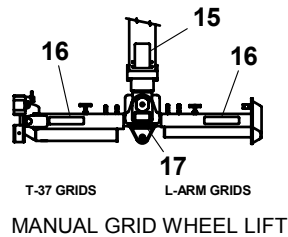
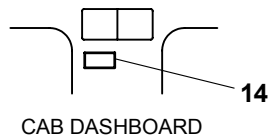
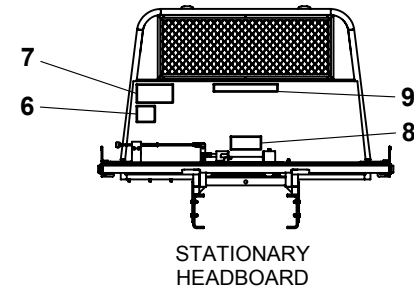
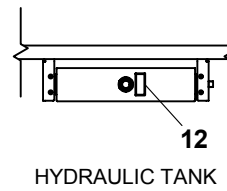
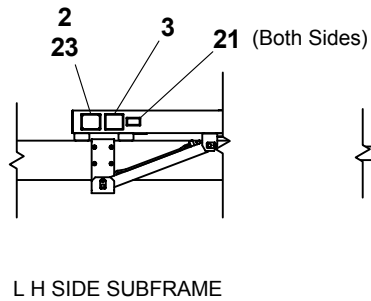
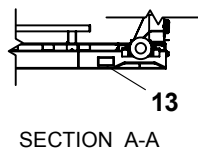
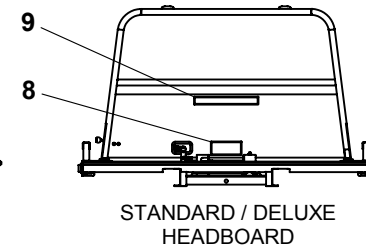
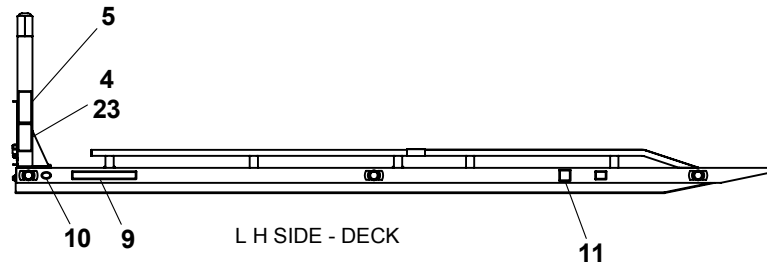
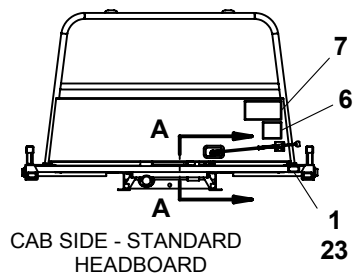

Item #22, Decal Kit, not shown

HYDRAULIC SCHEMATIC

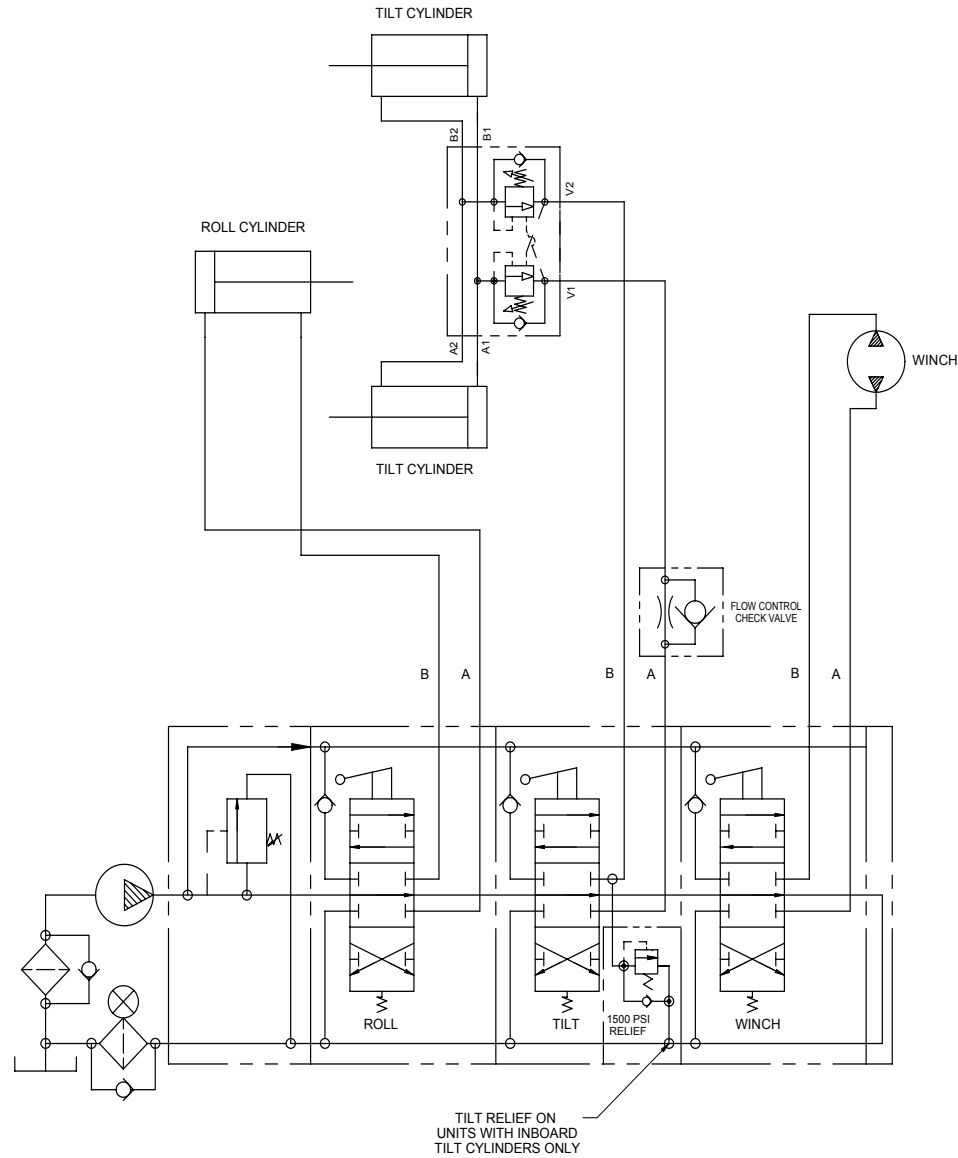

3 Bank Control Valve - No Tow Options

HYDRAULIC SCHEMATIC

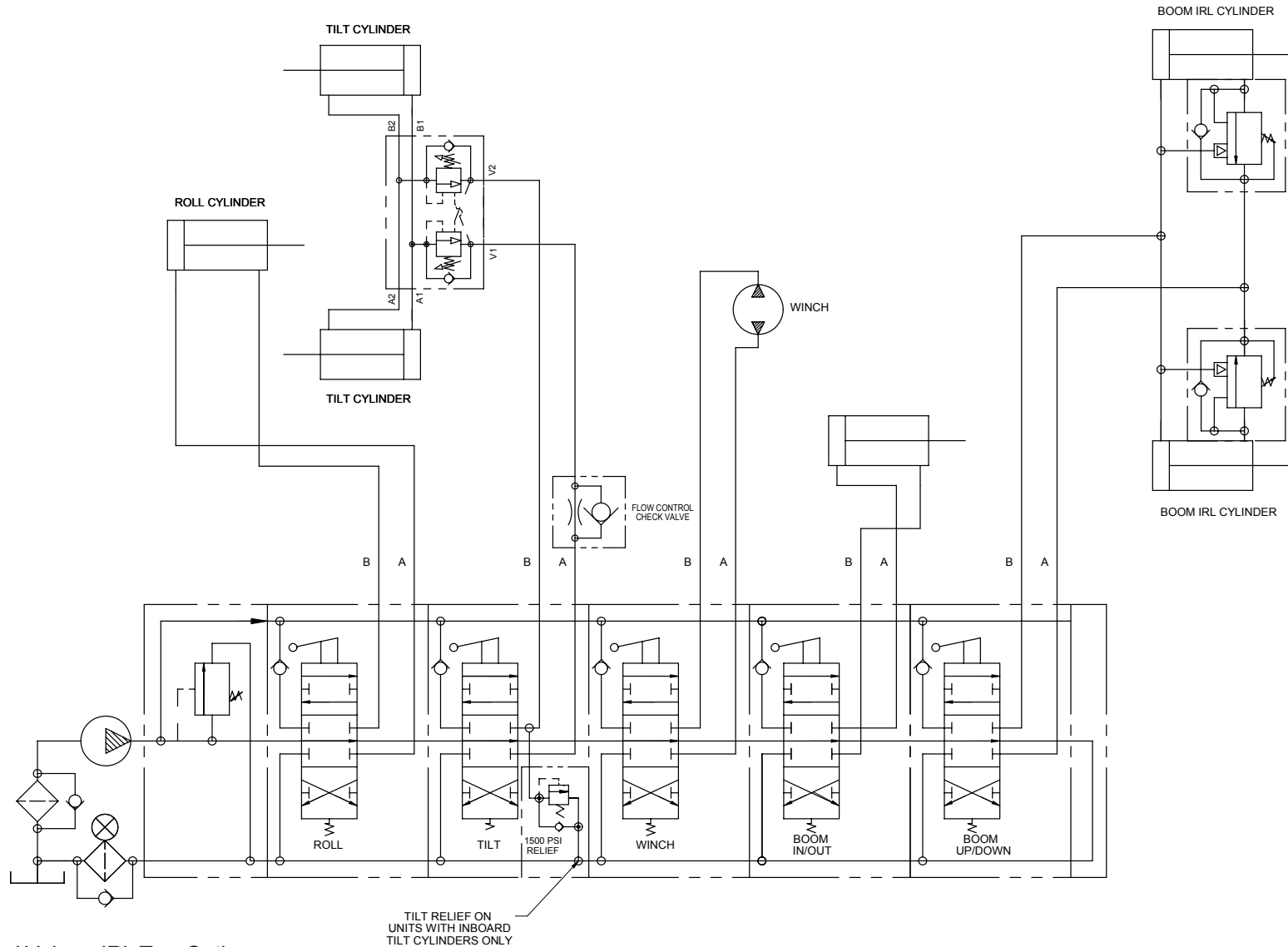

5 Bank Control Valve - IRL Tow Options

HYDRAULIC SCHEMATIC

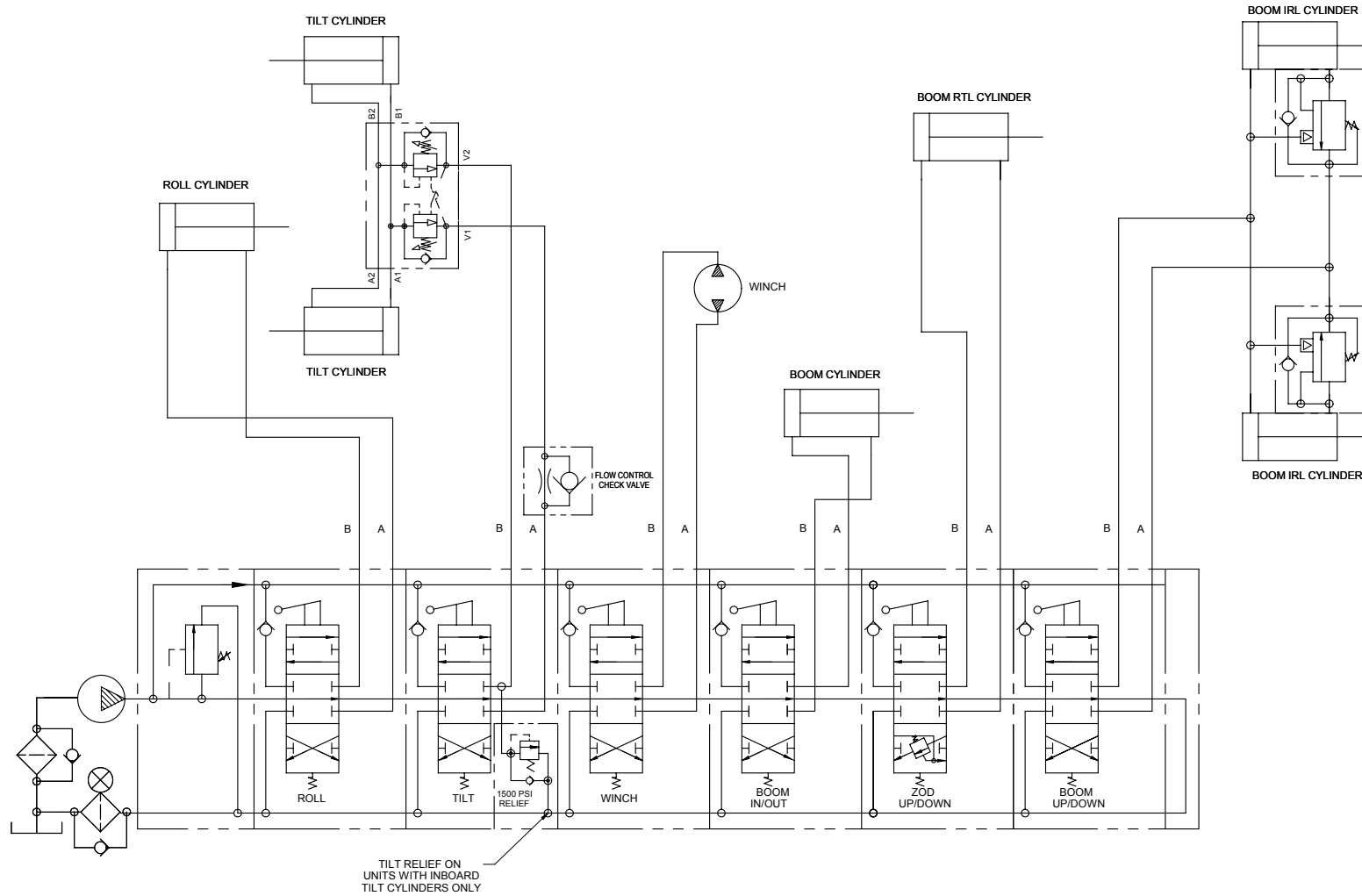

TILT RELIEF ON
UNITS WITH INBOARD
TILT CYLINDERS ONLY

6 Bank Control Valve - ZOD Tow Option

HYDRAULIC SCHEMATIC

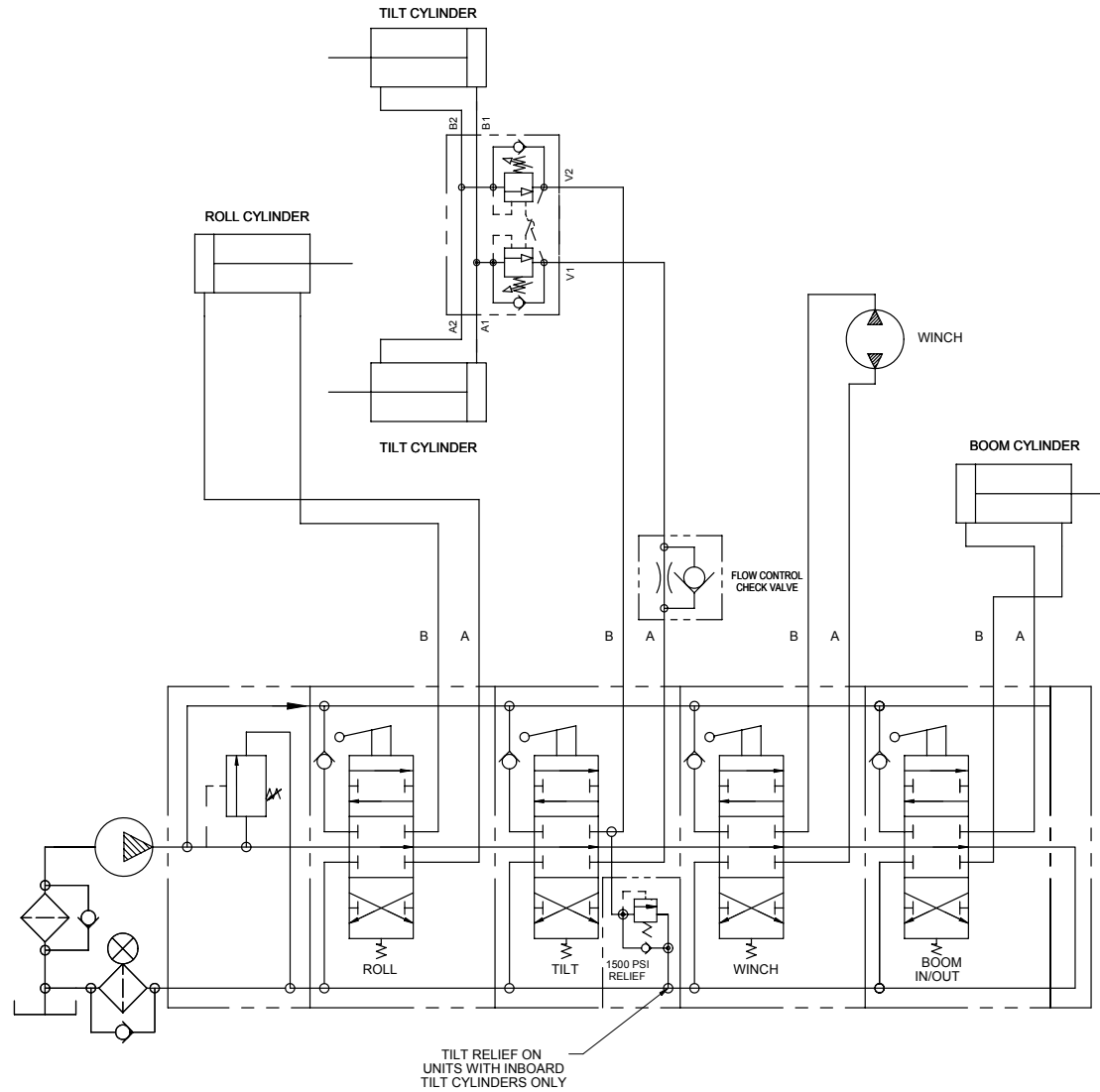

4 Bank Control Valve - Hydraulic Extended Boom Tow Options

HYDRAULIC SCHEMATIC

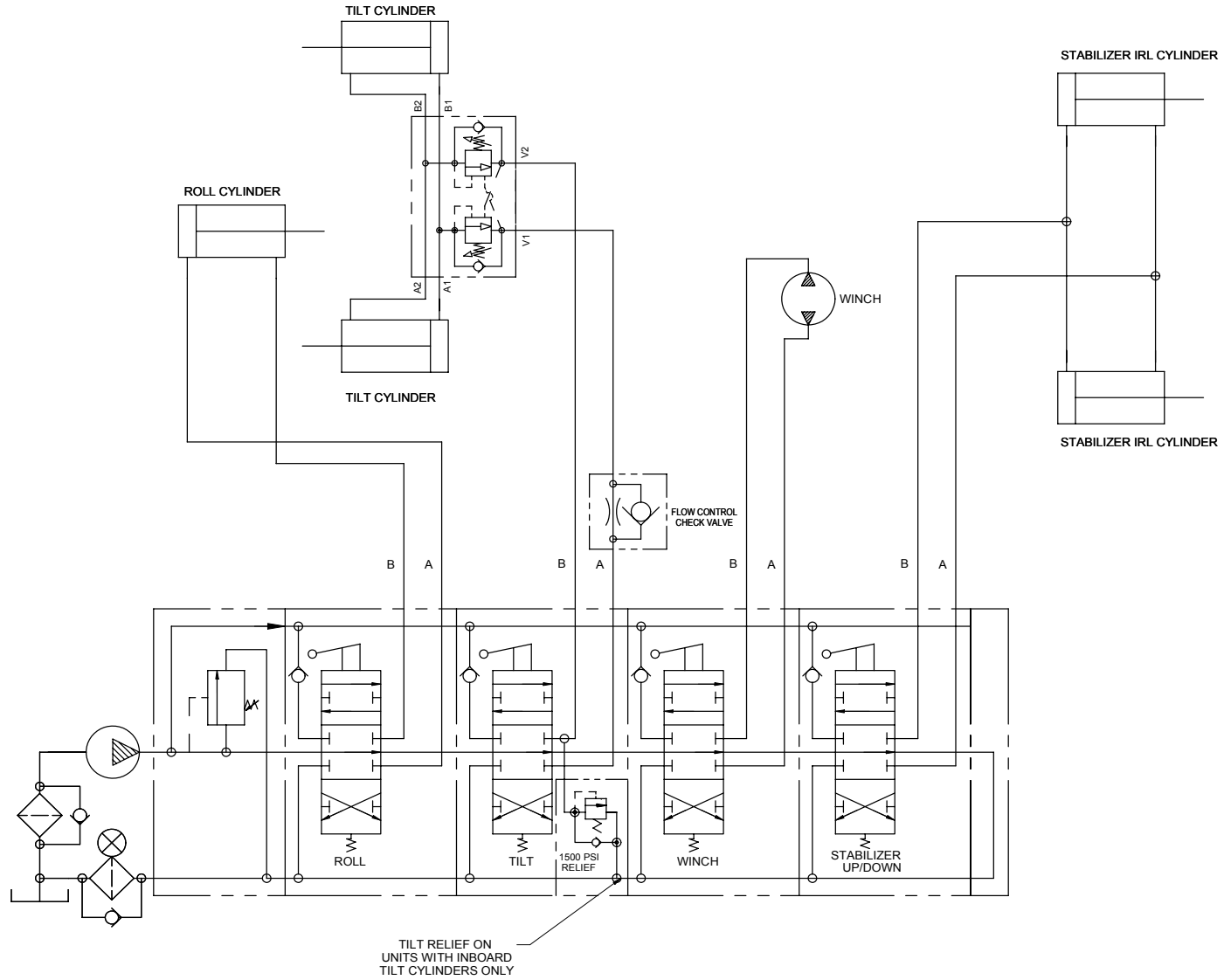

4 Bank Control Valve - Stabilizer Option

HYDRAULIC SCHEMATIC

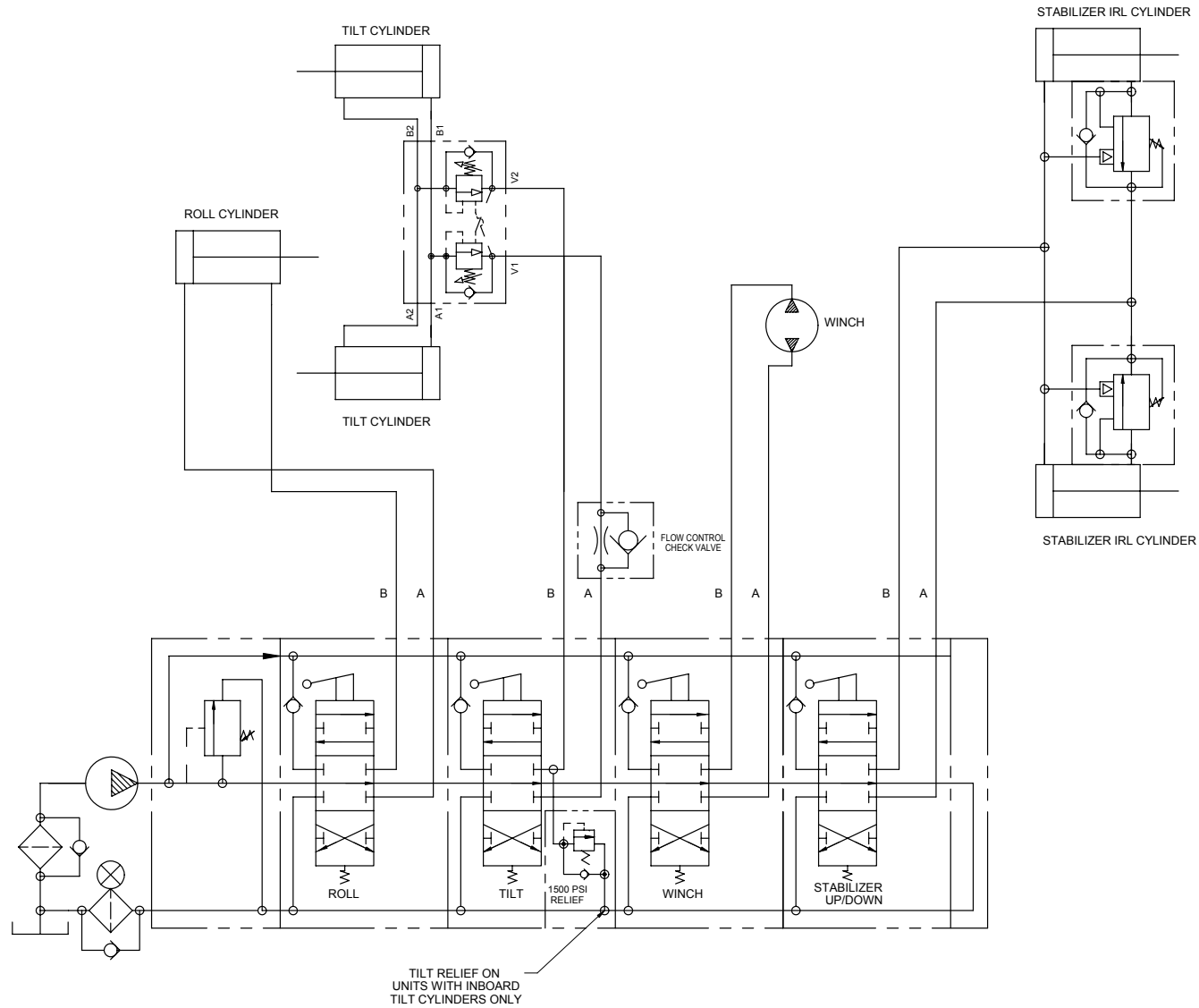

4 Bank Control Valve - Stabilizer with Tow Options

HYDRAULIC SCHEMATIC

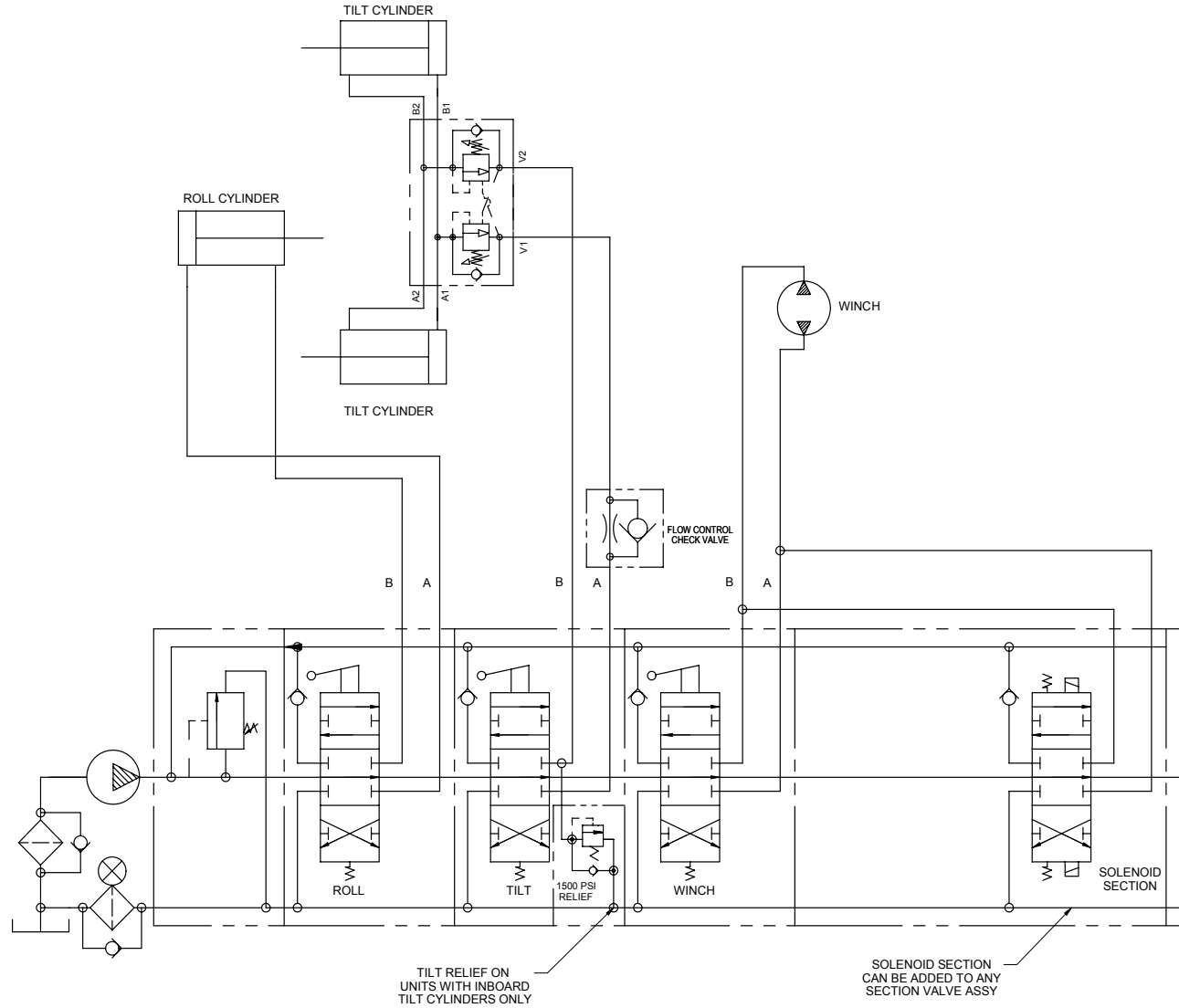

3 + 1 Bank Control Valve - Solenoid Section for Remote Control Winch

ELECTRICAL SCHEMATIC

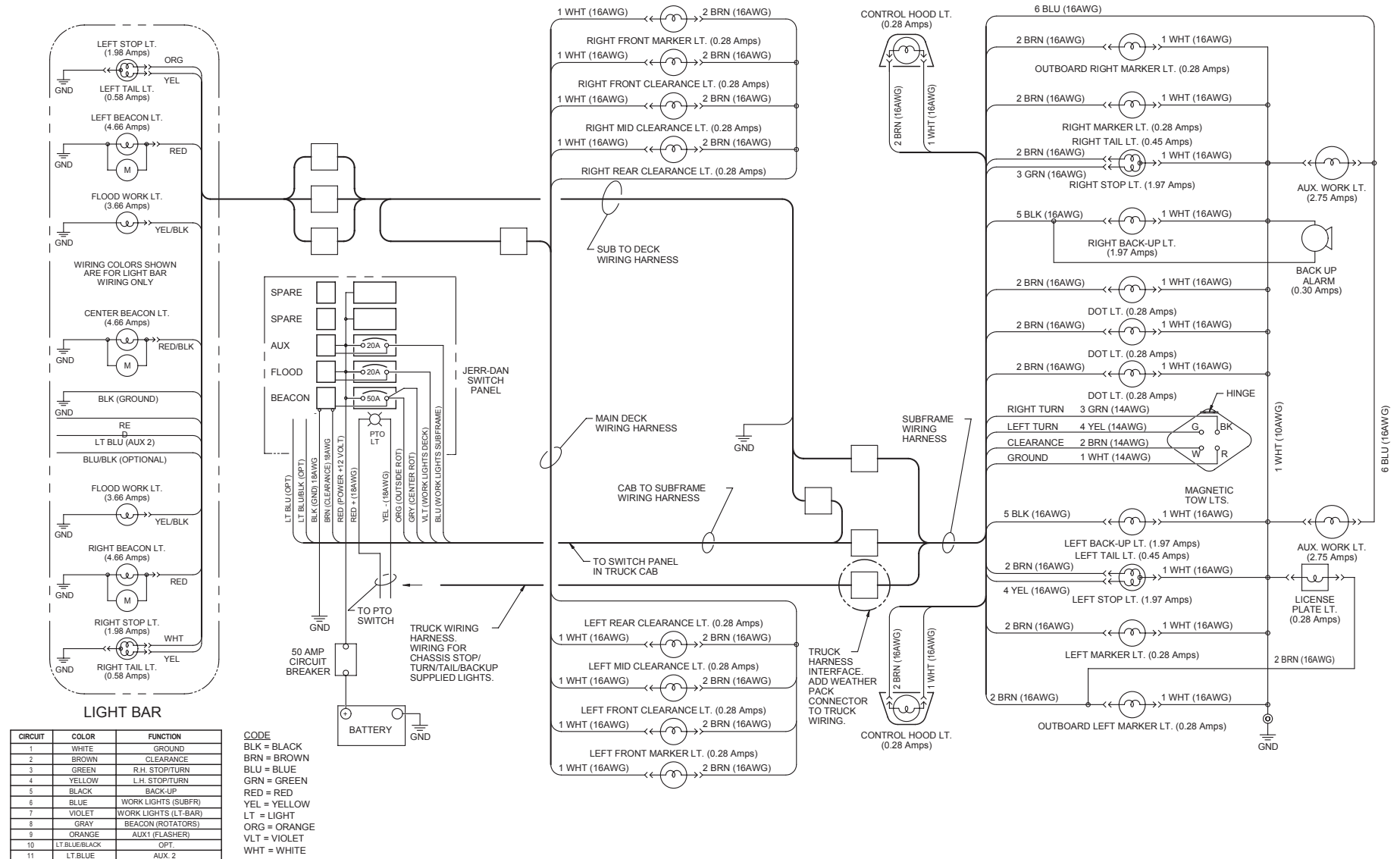

THIS PAGE INTENTIONALLY LEFT BLANK