

# STANDARD DUTY CARRIER PARTS MANUAL

# ***JERR-DAN***<sup>®</sup>

An Oshkosh Corporation Company

1080 Hykes Road  
Greencastle, PA 17225  
Phone (717) 597-7111  
[www.jerr-dan.com](http://www.jerr-dan.com)

5-376-000089  
Rev 06 - November 01, 2009

© 2009 Jerr-Dan Corporation. All Rights Reserved.

This manual covers the following Jerr-Dan Models:

NGAF	-	5 Ton Aluminum Pioneer Fixed Rail	WSRB	-	5 Ton Steel Rustler
NGADF	-	5 Ton Aluminum Pioneer Dual Angle Fixed Rail	SPRR5T	-	5 Ton Steel Panel Removable Rail
NGAR	-	5 Ton Aluminum Pioneer Removable Rail	RRSB	-	5 Ton Steel Removable Rail B.I.C.
SPFR5T	-	5 Ton Steel Panel Fixed Rail	SLPB	-	5 Ton Steel Shark
NGAT	-	5 Ton Aluminum Pioneer Transporter	STRB	-	5 Ton Steel B.I.C. Transporter
SRR6T-W	-	6 Ton Premium Steel Removable Rail	SRRD6T	-	6 Ton Premium Steel Shark

Jerr-Dan Corporation strives to provide information that is accurate, complete and useful. Descriptions and illustrative material contained within this manual are as accurate as known at the time of publication and are subject to change, without notice, as a result of continuous product improvements. Jerr-Dan reserves the right to amend the information in this document at any time without prior notice.

Information contained in this manual reflects how this vehicle was built at the factory. Modifications or additions by the distributor or owner are not reflected in this manual.

This parts manual does not include service parts information for the commercial chassis (IHC, Ford, GM, etc.). That information is provided by the chassis manufacturer.

When ordering parts, please refer to your unit's Sales Order Number, Serial Number and Model Number. This information is found on the aluminum tag riveted to the front left corner of the deck as shown below:

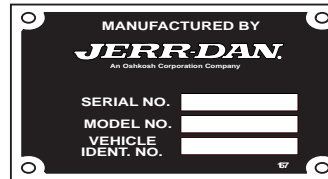

Additional or replacement manuals can be ordered by calling Jerr-Dan Parts at 717-597-7111. Price and availability will be quoted at time of the request.

Please report comments and/or errors by contacting Jerr-Dan Corporation's Technical Publications Department by e-mail at [technicalpublications@jerr-dan.com](mailto:technicalpublications@jerr-dan.com) or by FAX on 717-593-2362.

Manufactured under one or more of the following patents: 5,133,633; 5,575,606; 5,697,741; 5,951,235; 6,231,294 B1; 6,315,515 B1; 6,336,783 B1; 6,447,239 B2 and 7,264,305 B2 with other Patents Pending.

Jerr-Dan and the Jerr-Dan logo are registered trademarks and Run Hard is a service mark of Jerr-Dan Corporation, Greencastle, PA USA.

The material in this document is confidential and the property of Jerr-Dan Corporation. No part of this document may be photocopied, reproduced or translated to another language without the express written consent of Jerr-Dan Corporation.

# INDEX

DESCRIPTION	PAGE	DESCRIPTION	PAGE
Deck - 5 Ton Aluminum Pioneer Fixed Rail (NGAF) .....	6 - 7	Toolbox Light .....	98 - 99
Deck - 5 Ton Aluminum Pioneer Dual Angle Fixed Rail (NGADF) .....	8 - 9	Toolbox Top Stowage Tray and Marker Lights .....	100 - 101
Deck - 5 Ton Aluminum Pioneer Removable Rail (NGAR) .....	10 - 11	Dual Controls - 3 Bank .....	102 - 103
Deck - 5 Ton Aluminum Pioneer Transporter (NGAT) .....	12 - 13	Dual Controls - 4 Bank .....	104 - 105
Deck - 5 Ton Steel Rustler (WSRB) .....	14 - 15	Dual Controls - 5 Bank .....	106 - 107
Deck - 5 Ton Steel Panel Removable Rail (SPRR5T) .....	16 - 17	Dual Controls - 6 Bank .....	108 - 109
Deck - 5 Ton Steel Panel Shark (SPRRD5T) .....	18 - 19	Dual Controls - 7 Bank .....	110 - 111
Deck - 5 Ton Steel Panel Fixed Rail (SPFR5T) .....	20 - 21	Hydraulic Components - Standard .....	112 - 113
Deck - 5 Ton Steel Removable Rail B.I.C (RRSB) .....	22 - 23	Hydraulic Components - Standard (Hose Track) .....	114 - 115
Deck - 5 Ton Steel B.I.C. Transporter (STRB) .....	24 - 25	Hydraulic Components - Hose Routing / Mounting (Ford, GM & IHC) .....	116 - 117
Deck - 6 Ton Premium Steel Removable Rail (SRR6T-W) .....	26 - 27	Hydraulic Components - Hose Routing / Mounting (Dodge) .....	118 - 119
Deck - 6 Ton Premium Steel Shark (SRRD6T-W) .....	28 - 29	Hydraulic Components - IRL Wheel Lift w/ Manual Grids .....	120 - 121
Steel Bolt-In Keyslots .....	30 - 31	Hydraulic Components - IRL Wheel Lift w/ Hydraulic Grids .....	122 - 123
Adjustable Roll Cylinder Bracket - Deck .....	32 - 33	Hydraulic Components - ZOD Wheel Lift w/ Manual Grids .....	124 - 125
Standard Headboard & Standard Winch Free Spool .....	34 - 35	Hydraulic Components - ZOD Wheel Lift w/ Hydraulic Grids .....	126 - 127
Deluxe Headboard & Standard Winch Free Spool .....	36 - 37	Hydraulic Components - Stabilizer .....	128 - 129
Modular Headboard .....	38 - 39	Hydraulic Components - Stabilizer w/ Reese Hitch Rcrv or Pintle Hitch Mtg Plate .....	130 - 131
Bucket Rest Headboard .....	40 - 41	Hydraulic Components - Stabilizer w/ Hydraulic Extend Pintle Hitch Mtg Plate .....	132 - 133
Stationary Headboard & Standard Winch Free Spool .....	42 - 43	Hydraulic Components - IRL Tow Option .....	134 - 135
Worm Gear Winch .....	44 - 45	Hydraulic Components - Hydraulic Extend Tow Option .....	136 - 137
Planetary Gear Winch .....	46 - 47	Electrical Components - Standard w/ Bolt-On Headboard .....	138 - 139
Worm Gear Winch Cable Roller / Tensioner Plate .....	48 - 49	Electrical Components - Standard w/ Stationary Headboard .....	140 - 141
Planetary Gear Winch Cable Roller / Tensioner Plate .....	50 - 51	Deck Marker Lights .....	142 - 143
Remote Air Free Spool .....	52 - 53	Headboard Side Marker Lights .....	144 - 145
Subframe (Outboard Tilt Cylinders) .....	54 - 55	Electrical Components - Optional .....	146 - 147
Subframe (Inboard Tilt Cylinders) .....	56 - 57	Additional Deck Marker Lights .....	148 - 149
Hold Down (Outboard Tilt Cylinders) .....	58 - 59	IRL Wheel Lift .....	150 - 151
Hold Down (Inboard Tilt Cylinders) .....	60 - 61	ZOD Wheel Lift .....	152 - 153
Slide Pad .....	62 - 63	Manual L-Arm Wheel Lift Grid .....	154 - 155
Mud Flap .....	64 - 65	Manual T37 Pivoting Wheel Lift Grid .....	156 - 157
Mud Flap - Ford F550 & Dodge Ram 5500 .....	66 - 67	Hydraulic Wheel Lift Grid .....	158 - 163
Final Assembly .....	68 - 69	Hydraulic Rear Dock Stabilizer .....	164 - 161
Final Assembly - Galvanized Subframe .....	70 - 71	Stabilizer w/ Reese Hitch Receiver .....	166 - 163
Ford F550 Frame Reinforcement and Spring Spacers .....	72 - 73	Stabilizer w/ Manual Extend Pintle Hitch Mounting Plate .....	168 - 165
Ford F550 Subframe Modifications .....	74 - 75	Stabilizer w/ Hydraulic Extend Pintle Hitch Mounting Plate .....	170 - 167
GM C4500/5500 Subframe Modifications .....	76 - 77	Ball Hitch Mounting Plate - IRL .....	172 - 169
GM C4500/5500 Brake Cable Rework and Rear Fuel Tank Modification .....	78 - 79	Ball Hitch Mounting Plate - Hydraulic Extend .....	174 - 175
Dodge Ram 5500 Frame Reinforcement .....	80 - 81	Ball Hitch Mounting Plate - Manual Extend .....	176 - 177
Dodge Ram 5500 Brake Cable Rework .....	82 - 83	Pintle Hitch Mounting Plate - IRL .....	178 - 179
Dodge Ram 5500 Fuel Tank Hose Install .....	84 - 85	Pintle Hitch Mounting Plate - Hydraulic Extend .....	180 - 181
Isuzu NRR Frame Reinforcement - 21' Deck .....	86 - 87	Pintle Hitch Mounting Plate - Manual Extend .....	182 - 183
Hydraulic Reservoir and Toolbox / Basket .....	88 - 93	Towbar - IRL .....	184 - 185
Toolbox .....	94 - 95	Towbar - Hydraulic Extend .....	186 - 187
Toolbox Shelf .....	96 - 97	Roll Cylinder Assembly .....	188 - 189

# INDEX

<u>DESCRIPTION</u>	<u>PAGE</u>
Tilt Cylinder Assembly 5 Ton (Outboard) .....	190 - 191
Tilt Cylinder Assembly 6 Ton (Outboard) .....	192 - 193
Tilt Cylinder Assembly (Inboard) .....	194 - 195
Wheel Lift Extend Cylinder Assembly .....	196 - 197
IRL Cylinder Assembly.....	198 - 199
ZOD Cylinder Assembly .....	200 - 201
Stabilizer Cylinder Assembly .....	202 - 203
Tow Option Hydraulic Extend Cylinder Assembly .....	204 - 205
Lightbars .....	206 - 207
Switch Panels .....	208 - 209
Work Lights .....	210 - 211
Bolt-On D-Rings .....	212 - 213
Remote Control Operation(s) .....	214 - 217
Remote Throttle Control .....	218 - 219
Glad Hands and 7-Way Connector .....	220 - 221
Air Supply Disconnect .....	222 - 223
Jump Start Kit .....	224 - 225
Folding Deck Ladder .....	226 - 227
Chains and Straps .....	228 - 229
Towing Safety Tools .....	230 - 231
Decals .....	232 - 233
Accessory Equipment .....	234 - 235
Hydraulic Schematic .....	236 - 244
Electrical Schematic .....	245

**THIS PAGE INTENTIONALLY LEFT BLANK**

**DECK - 5 TON ALUMINUM PIONEER FIXED RAIL (NGAF)**

ITEM	PART NO.	DESCRIPTION	QTY
1	3097000655	19' Deck - 96" wide	1
	3097000656	19' Deck - 102" wide	
	3097000665	20' Deck - 96" wide	
	3097000666	20' Deck - 102" wide	
	3097000675	21' Deck - 96" wide	
	3097000676	21' Deck - 102" wide	
2	7679000017	Chain Tray Mat	2

## DECK - 5 TON ALUMINUM PIONEER FIXED RAIL (NGAF)

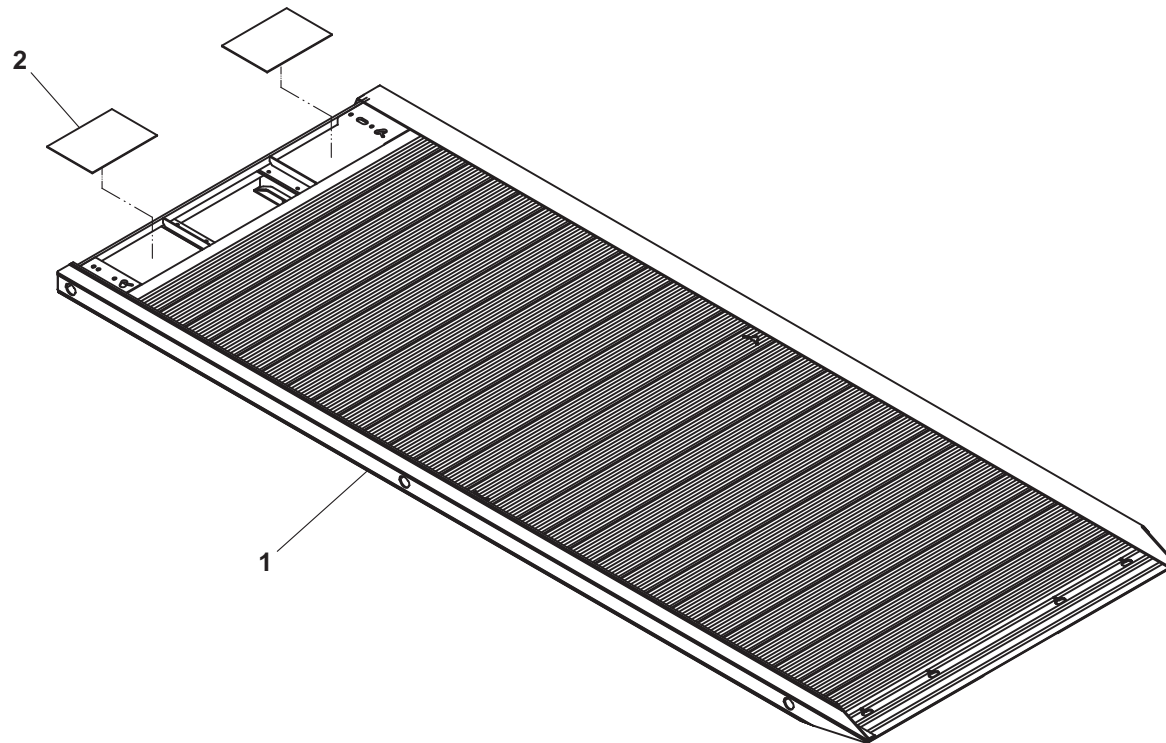

21' deck shown

**DECK - 5 TON ALUMINUM PIONEER DUAL ANGLE FIXED RAIL (NGADF)**

ITEM	PART NO.	DESCRIPTION	QTY
1	3097000661	19' Deck - 96" wide	1
	3097000662	19' Deck - 102" wide	
	3097000671	20' Deck - 96" wide	
	3097000672	20' Deck - 102" wide	
	3097000681	21' Deck - 96" wide	
	3097000682	21' Deck - 102" wide	
2	7679000017	Chain Tray Mat	2



## DECK - 5 TON ALUMINUM PIONEER DUAL ANGLE FIXED RAIL (NGADF)

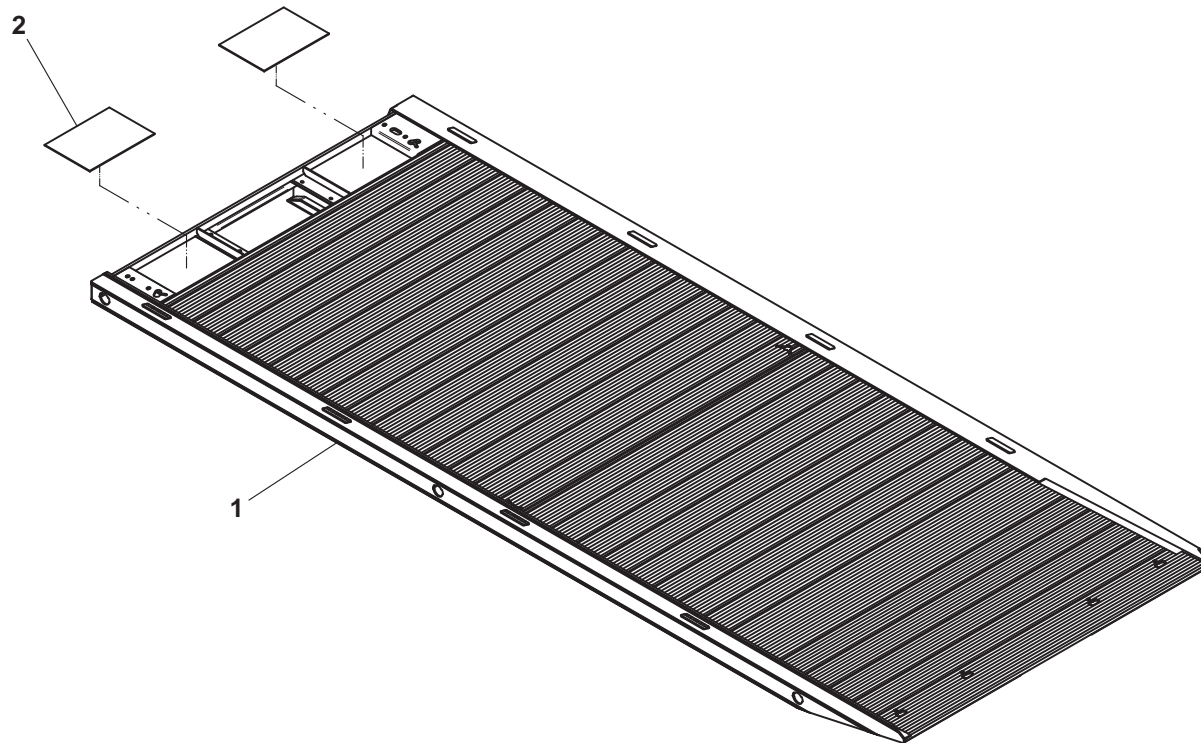

21' deck shown

**DECK - 5 TON ALUMINUM PIONEER REMOVABLE RAIL (NGAR)**

ITEM	PART NO.	DESCRIPTION	QTY	ITEM	PART NO.	DESCRIPTION	QTY
1	3097000653	19' Deck - 96" wide	1			<i>Standard Aluminum Removable Rails:</i>	
	3097000654	19' Deck - 102" wide					
	3097000663	20' Deck - 96" wide		10	3017000121	Angle Assembly LH Front	1
	3097000664	20' Deck - 102" wide		11	3017000122	Angle Assembly RH Front	1
	3097000673	21' Deck - 96" wide		12	3017000127	Angle Assembly LH Rear (19' & 20' decks)	1
	3097000674	21' Deck - 102" wide			3017000129	Angle Assembly LH Rear (21' deck)	
2	7679000017	Chain Tray Mat	2	13	3017000128	Angle Assembly RH Rear (19' & 20' decks)	1
					3017000130	Angle Assembly RH Rear (21' deck)	
				14	7661000055	U-Nut, 0.50"-13UN	10
				15	7120000005	Capscrew, 0.50"-13NC x 2.50"	10
						<i>Parts Breakdown of Angle Assemblies</i>	
				50	4017001699	Angle LH Front	1
				51	4017001700	Angle RH Front	
				52	4017001705	Angle LH Rear (19' & 20' decks)	1
					4017001707	Angle LH Rear (21' deck)	
				53	4017001706	Angle RH Rear (19' & 20' decks)	
					4017001708	Angle RH Rear (21' deck)	
				54	7115183664	Carriage Bolt, 0.50"-13NC x 4.50"	20
				55	8411080102	Extrusion	10
				56	4706006228	Plate	10
				57	7660182601	Locknut, 0.50"-13NC	20

# DECK - 5 TON ALUMINUM PIONEER REMOVABLE RAIL (NGAR)

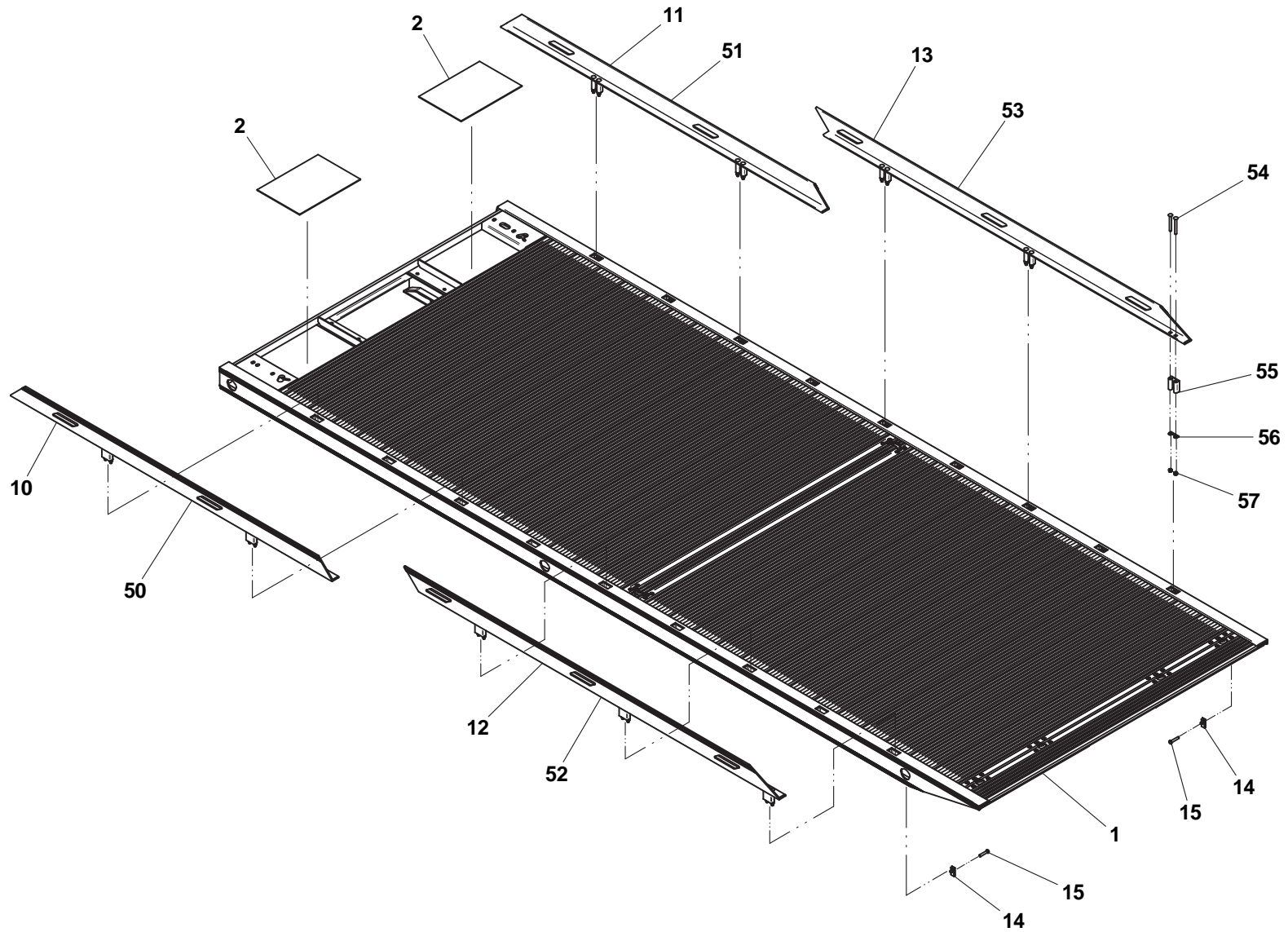

21' deck shown

**DECK - 5 TON ALUMINUM PIONEER TRANSPORTER (NGAT)**

ITEM	PART NO.	DESCRIPTION	QTY	ITEM	PART NO.	DESCRIPTION	QTY
1	3097000659	19' Deck - 95" wide, 8" X-mem spacing	1			<i>Standard Aluminum Removable Rails:</i>	
	3097000660	19' Deck - 102" wide, 8" X-mem spacing					
	3097000669	20' Deck - 95" wide, 8" X-mem spacing		10	3017000121	Angle Assembly LH Front	1
	3097000670	20' Deck - 102" wide, 8" X-mem spacing		11	3017000122	Angle Assembly RH Front	1
	3097000679	21' Deck - 95" wide, 8" X-mem spacing		12	3017000127	Angle Assembly LH Rear (19' & 20' decks)	1
	3097000680	21' Deck - 102" wide, 8" X-mem spacing			3017000129	Angle Assembly LH Rear (21' deck)	
2	7679000017	Chain Tray Mat	2	13	3017000128	Angle Assembly RH Rear (19' & 20' decks)	1
3	Contact Parts	Keruing Board	A/R		3017000130	Angle Assembly RH Rear (21' deck)	
4	7786000007	Screw, 0.31"-18NC x 2.00"	A/R	14	7661000055	U-Nut, 0.50"-13NC	10
				15	7120000005	Capscrew, 0.50"-13NC x 2.50"	10
						<i>Parts Breakdown of Angle Assemblies</i>	
				50	4017001699	Angle LH Front	1
				51	4017001700	Angle RH Front	
				52	4017001705	Angle LH Rear (19' & 20' decks)	1
					4017001707	Angle LH Rear (21' deck)	
				53	4017001706	Angle RH Rear (19' & 20' decks)	
					4017001708	Angle RH Rear (21' deck)	
				54	7115183664	Carriage Bolt, 0.50"-13NC x 4.50"	20
				55	8411080102	Extrusion	10
				56	4706006228	Plate	10
				57	7660182601	Locknut, 0.50"-13NC	20

# DECK - 5 TON ALUMINUM PIONEER TRANSPORTER (NGAT)

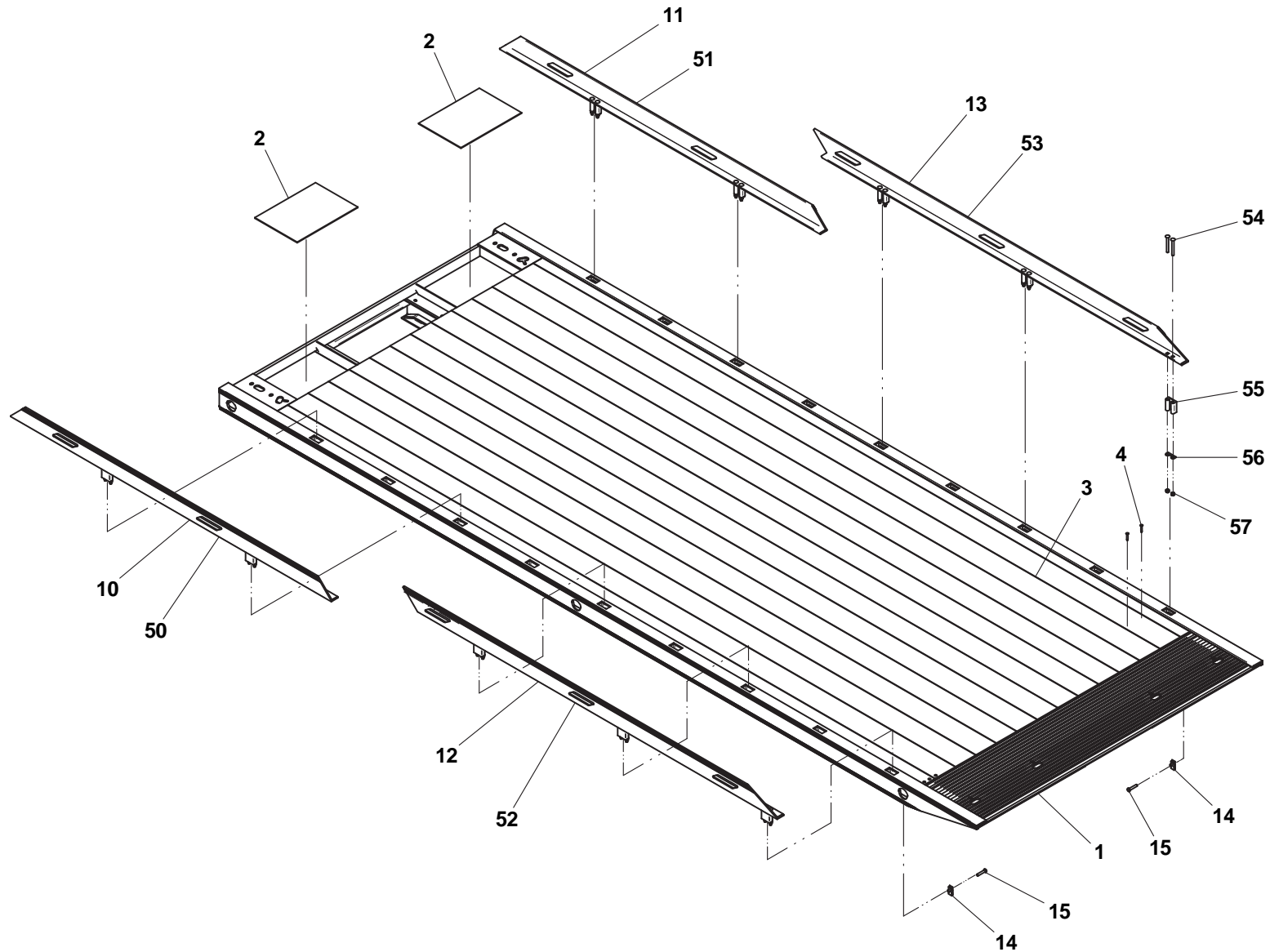

21' deck shown

**DECK - 5 TON STEEL RUSTLER (WSRB)**

ITEM	PART NO.	DESCRIPTION	QTY
1	3097000265	19' Deck - 96" wide, 12" X-mem spacing	1
	3097000280	19' Deck - 96" wide, 8" X-mem spacing	
	3097000456	19' Deck - 102" wide, 12" X-mem spacing	
	3097000460	19' Deck - 102" wide, 8" X-mem spacing	
	3097000455	20' Deck - 96" wide, 12" X-mem spacing	
	3097000459	20' Deck - 96" wide, 8" X-mem spacing	
	3097000457	20' Deck - 102" wide, 12" X-mem spacing	
	3097000461	20' Deck - 102" wide, 8" X-mem spacing	
	3097000296	21' Deck - 96" wide, 12" X-mem spacing	
	3097000297	21' Deck - 96" wide, 8" X-mem spacing	
	3097000458	21' Deck - 102" wide, 12" X-mem spacing	
	3097000462	21' Deck - 102" wide, 8" X-mem spacing	

## DECK - 5 TON STEEL RUSTLER (WSRB)

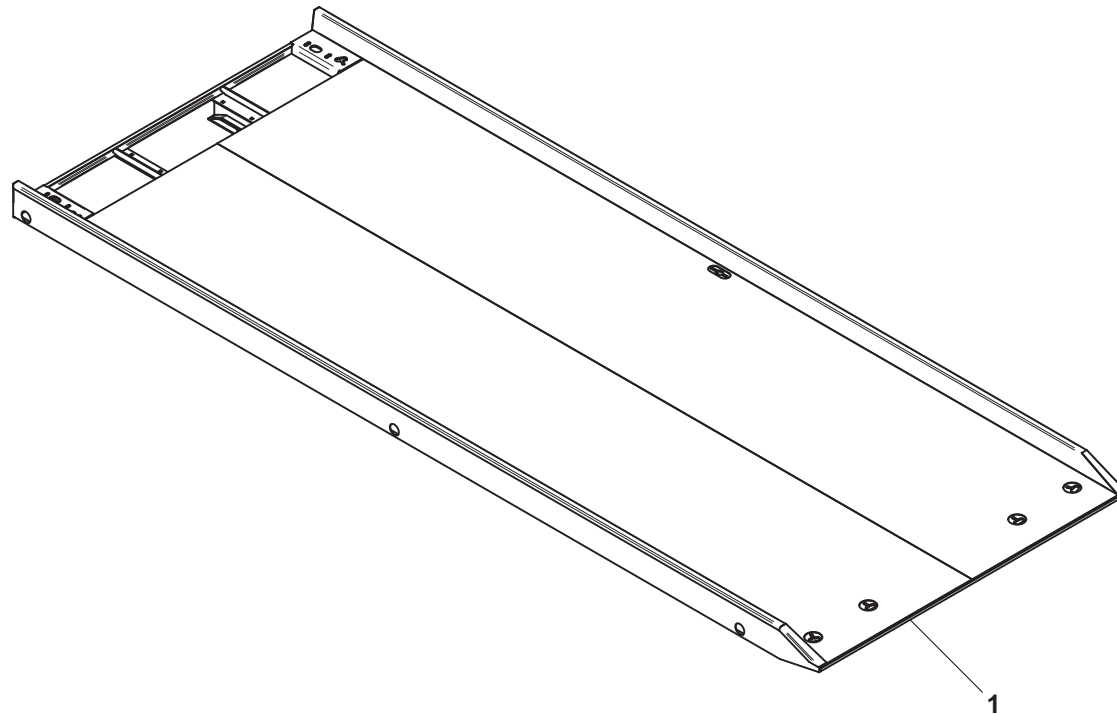

21' deck shown

**DECK - 5 TON STEEL PANEL REMOVABLE RAIL (SPRR5T)**

ITEM	PART NO.	DESCRIPTION	QTY	ITEM	PART NO.	DESCRIPTION	QTY
1	3097000735	19' Deck - 96" wide	1			<i>Standard Steel Tubular Removable Rails:</i>	
	3097000736	19' Deck - 102" wide					
	3097000733	20' Deck - 96" wide		10	3017000259	Rail Weldment Front (19' & 20' decks)	2
	3097000734	20' Deck - 102" wide			3017000260	Rail Weldment Front (21' deck)	
	3097000711	21' Deck - 96" wide		11	3017000262	Rail Weldment Rear (19' & 20' decks)	2
	3097000732	21' Deck - 102" wide			3017000261	Rail Weldment Rear (21' deck)	
				12	7115181050	Capscrew, 0.50"-13NC x 1.25"	10
				13	7701000033	End Cap	4
						<i>Optional Aluminum Removable Rails:</i>	
				20	3017000121	Angle Assembly LH Front	1
				21	3017000122	Angle Assembly RH Front	1
				22	3017000127	Angle Assembly LH Rear (19' & 20' decks)	1
					3017000129	Angle Assembly LH Rear (21' deck)	
				23	3017000128	Angle Assembly RH Rear (19' & 20' decks)	1
					3017000130	Angle Assembly RH Rear (21' deck)	
				24	7120000005	Capscrew, 0.50"-13NC x 2.50"	10
						<i>Parts Breakdown of Angle Assemblies</i>	
				50	4017001699	Angle LH Front	1
				51	4017001700	Angle RH Front	
				52	4017001705	Angle LH Rear (19' & 20' decks)	1
					4017001707	Angle LH Rear (21' deck)	
				53	4017001706	Angle RH Rear (19' & 20' decks)	
					4017001708	Angle RH Rear (21' deck)	
				54	7115183664	Carriage Bolt, 0.50"-13NC x 4.50"	20
				55	8411080102	Extrusion	10
				56	4706006228	Plate	10
				57	7660182601	Locknut, 0.50"-13NC	20



## DECK - 5 TON STEEL PANEL REMOVABLE RAIL (SPRR5T)

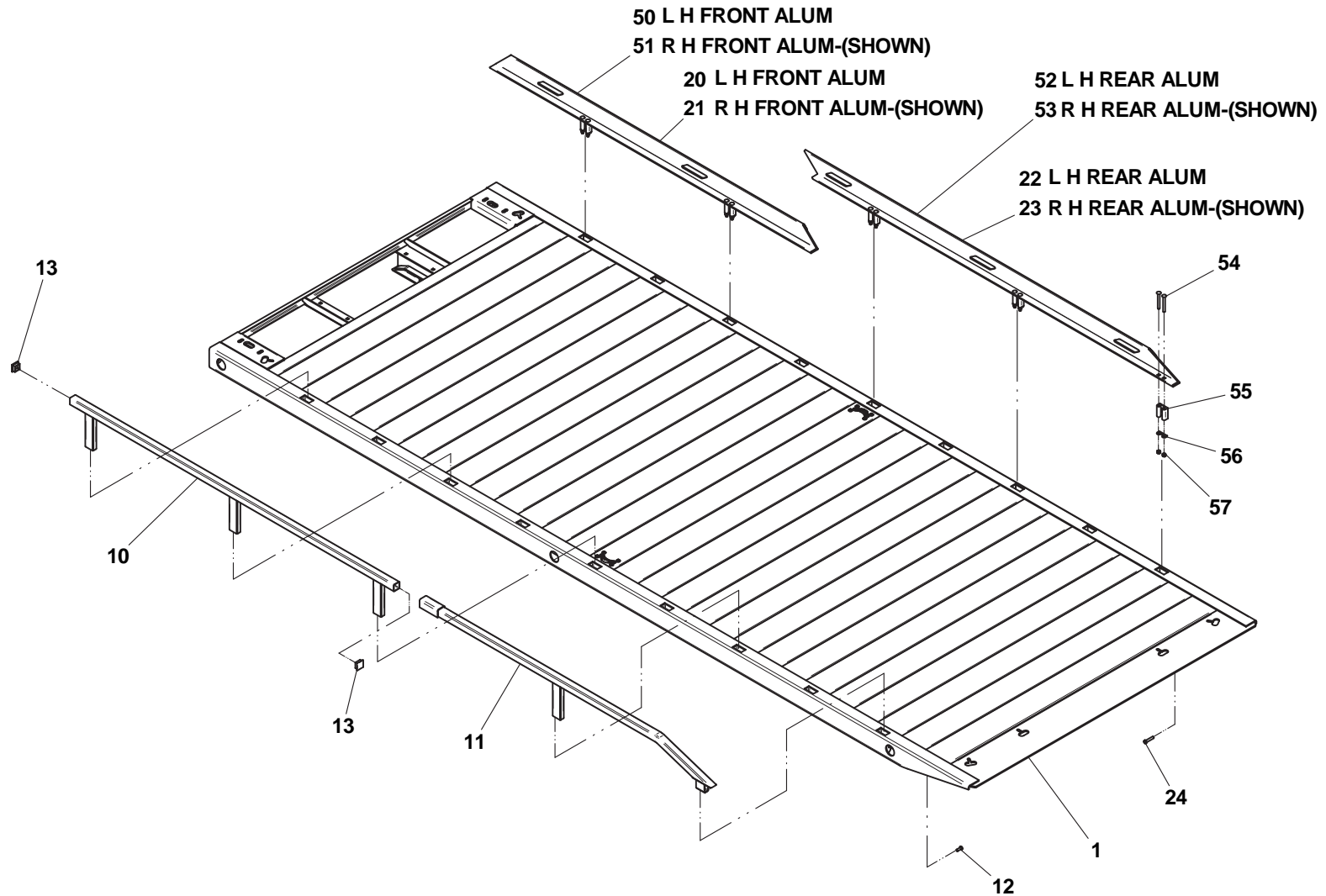

21' deck shown with standard removable steel rails on left side and optional aluminum removable rails on right side

**DECK - 5 TON STEEL PANEL SHARK (SPRRD5T)**

ITEM	PART NO.	DESCRIPTION	QTY
1	3097000740	19' Deck - 96" wide	1
	3097000741	20' Deck - 96" wide	
	3097000742	21' Deck - 96" wide	
2	3017000135	Angle Assembly LH (19' deck)	1
	3017000137	Angle Assembly LH (20' deck)	
	3017000139	Angle Assembly LH (21' deck)	
3	3017000136	Angle Assembly RH (19' deck)	1
	3017000138	Angle Assembly RH (20' deck)	
	3017000140	Angle Assembly RH (21' deck)	
4	7120000005	Capscrew, 0.50"-13NC x 2.50" (19' & 20' decks)	8
	7120000005	Capscrew, 0.50"-13NC x 2.50" (21' deck)	10
<i>Parts Breakdown of Angle Assemblies</i>			
50	4017001713	Angle LH (19' deck)	1
	4017001715	Angle LH (20' deck)	
	4017001717	Angle RH (21' deck)	
51	4017001714	Angle LH (19' deck)	1
	4017001716	Angle LH (20' deck)	
	4017001718	Angle RH (21' deck)	
52	7115183664	Carriage Bolt, 0.50"-13NC x 4.50" (19' & 20' decks)	16
	7115183664	Carriage Bolt, 0.50"-13NC x 4.50" (21' deck)	20
53	8411080102	Extrusion (19' & 20' decks)	8
		Extrusion (21' deck)	10
54	4706006228	Plate (19' & 20' decks)	8
		Plate (21' deck)	10
55	7660182601	Locknut, 0.50"-13NC (19' & 20' decks)	16
		Locknut, 0.50"-13NC (21' deck)	20

# DECK - 5 TON STEEL PANEL SHARK (SPRRD5T)

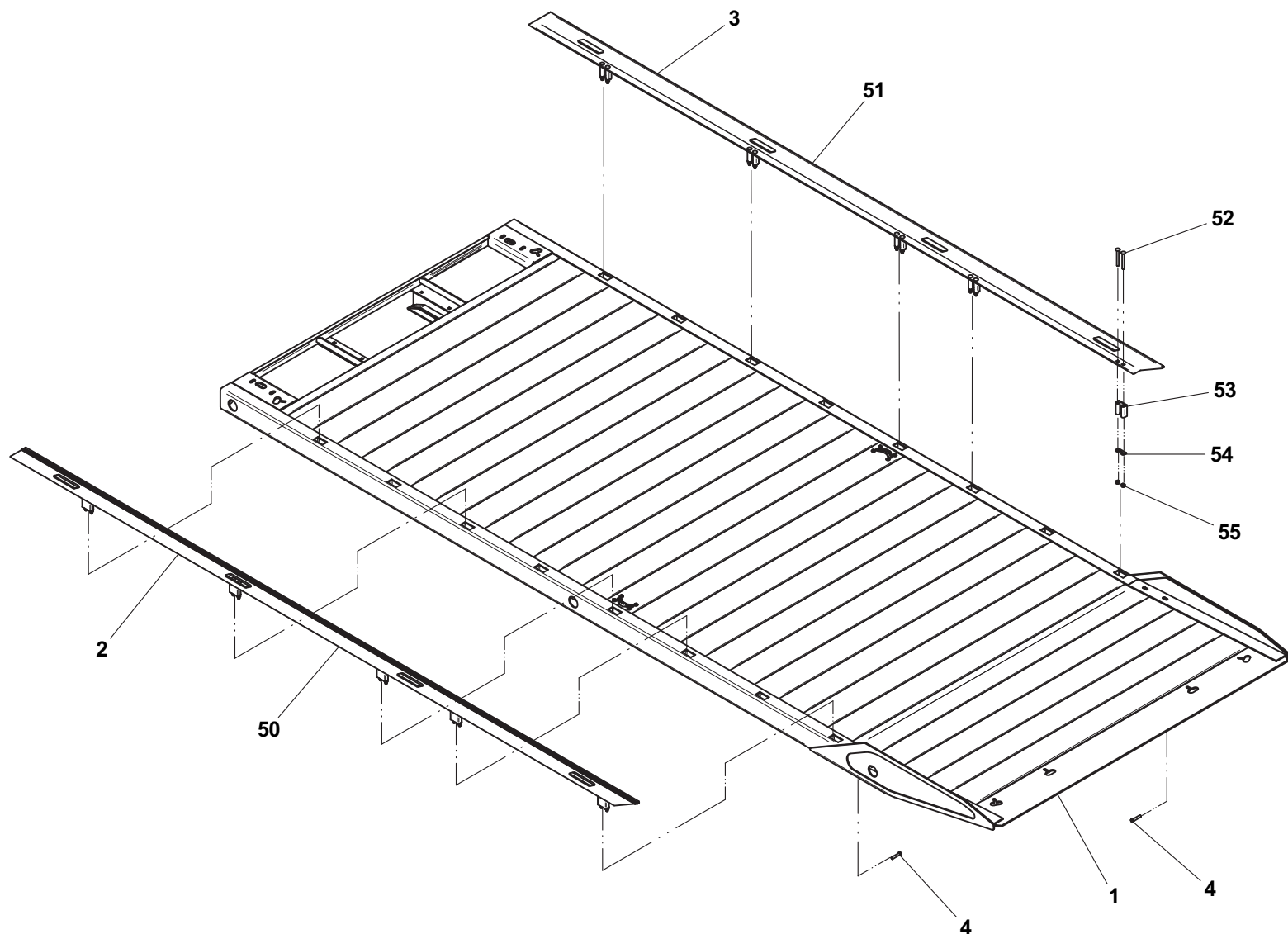

21' deck shown

**DECK - 5 TON STEEL PANEL FIXED RAIL (SPFR5T)**

ITEM	PART NO.	DESCRIPTION	QTY
1	3097000735	19' Deck - 96" wide	1
	3097000736	19' Deck - 102" wide	
	3097000733	20' Deck - 96" wide	
	3097000734	20' Deck - 102" wide	
	3097000711	21' Deck - 96" wide	
	3097000732	21' Deck - 102" wide	
	2	7115160864	
3	7950160161	Flatwasher, 0.38" ID	*
4	7660162601	Locknut, 0.38"-16NC	*
5	2729000038	Permanent Raised Rails (19' & 20' decks)	1
	2729000037	Permanent Raised Rails (21' decks)	1

## DECK - 5 TON STEEL PANEL FIXED RAIL (SPFR5T)

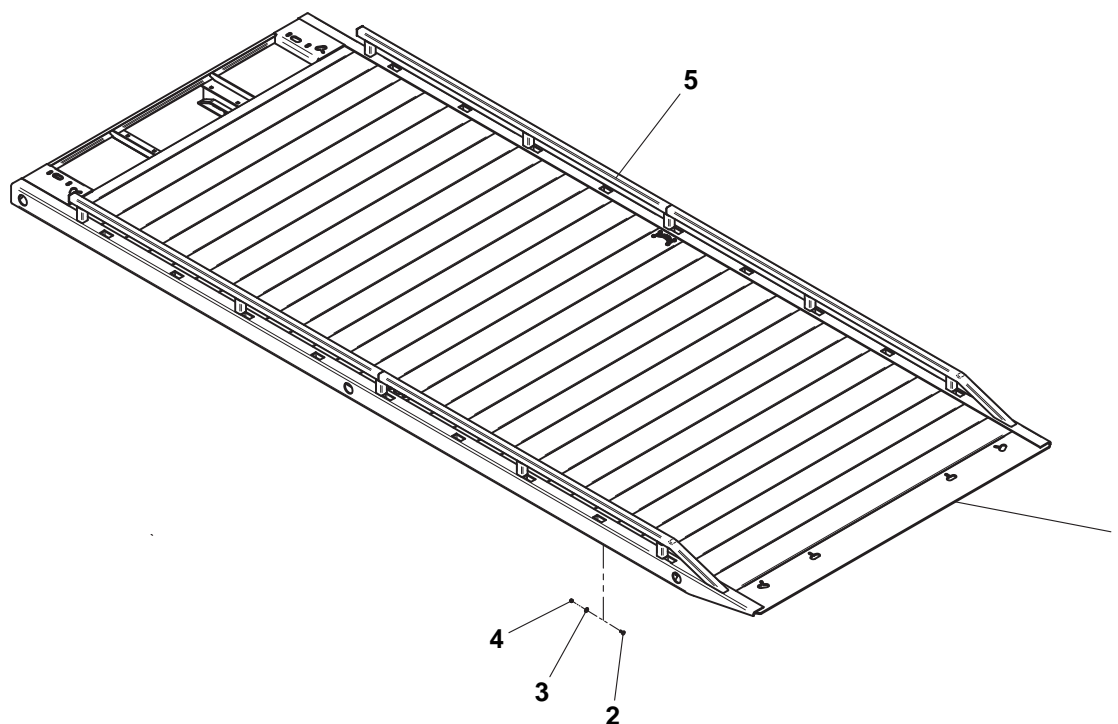

21' deck shown

**DECK - 5 TON STEEL REMOVABLE RAIL B.I.C. (RRSB)**

ITEM	PART NO.	DESCRIPTION	QTY	ITEM	PART NO.	DESCRIPTION	QTY
1	3097000270	19' Deck - 96" wide, 12" X-mem spacing	1			<i>Standard Steel Tubular Removable Rails:</i>	
	3097000281	19' Deck - 96" wide, 8" X-mem spacing					
	3097000448	19' Deck - 102" wide, 12" X-mem spacing		10	3729000115	Rail Weldment Front (19' & 20' decks)	2
	3097000452	19' Deck - 102" wide, 8" X-mem spacing			3729000126	Rail Weldment Front (21' deck)	
	3097000447	20' Deck - 96" wide, 12" X-mem spacing		11	3017000129	Rail Weldment LH Rear (19' & 20' decks)	1
	3097000451	20' Deck - 96" wide, 8" X-mem spacing			3017000127	Rail Weldment LH Rear (21' deck)	
	3097000449	20' Deck - 102" wide, 12" X-mem spacing		12	3017000130	Rail Weldment RH Rear (19' & 20' decks)	1
	3097000453	20' Deck - 102" wide, 8" X-mem spacing			3017000128	Rail Weldment RH Rear (21' deck)	
	3097000269	21' Deck - 96" wide, 12" X-mem spacing		13	7701000033	End Cap	4
	3097000284	21' Deck - 96" wide, 8" X-mem spacing		14	7115181050	Capscrew, 0.50"-13NC x 1.25"	10
	3097000450	21' Deck - 102" wide, 12" X-mem spacing					
	3097000454	21' Deck - 102" wide, 8" X-mem spacing				<i>Optional Aluminum Removable Rails:</i>	
				20	3017000121	Angle Assembly LH Front	1
				21	3017000122	Angle Assembly RH Front	1
				22	3017000127	Angle Assembly LH Rear (19' & 20' decks)	1
					3017000129	Angle Assembly LH Rear (21' deck)	
				23	3017000128	Angle Assembly RH Rear (19' & 20' decks)	1
					3017000130	Angle Assembly RH Rear (21' deck)	
				24	7120000005	Capscrew, 0.50"-13NC x 2.50"	10
						<i>Parts Breakdown of Angle Assemblies</i>	
				50	4017001699	Angle LH Front	1
				51	4017001700	Angle RH Front	
				52	4017001705	Angle LH Rear (19' & 20' decks)	1
					4017001707	Angle LH Rear (21' deck)	
				53	4017001706	Angle RH Rear (19' & 20' decks)	
					4017001708	Angle RH Rear (21' deck)	
				54	7115183664	Carriage Bolt, 0.50"-13NC x 4.50"	20
				55	8411080102	Extrusion	10
				56	4706006228	Plate	10
				57	7660182601	Locknut, 0.50"-13NC	20

# DECK - 5 TON REMOVABLE RAIL STEEL B.I.C. (RRSB)

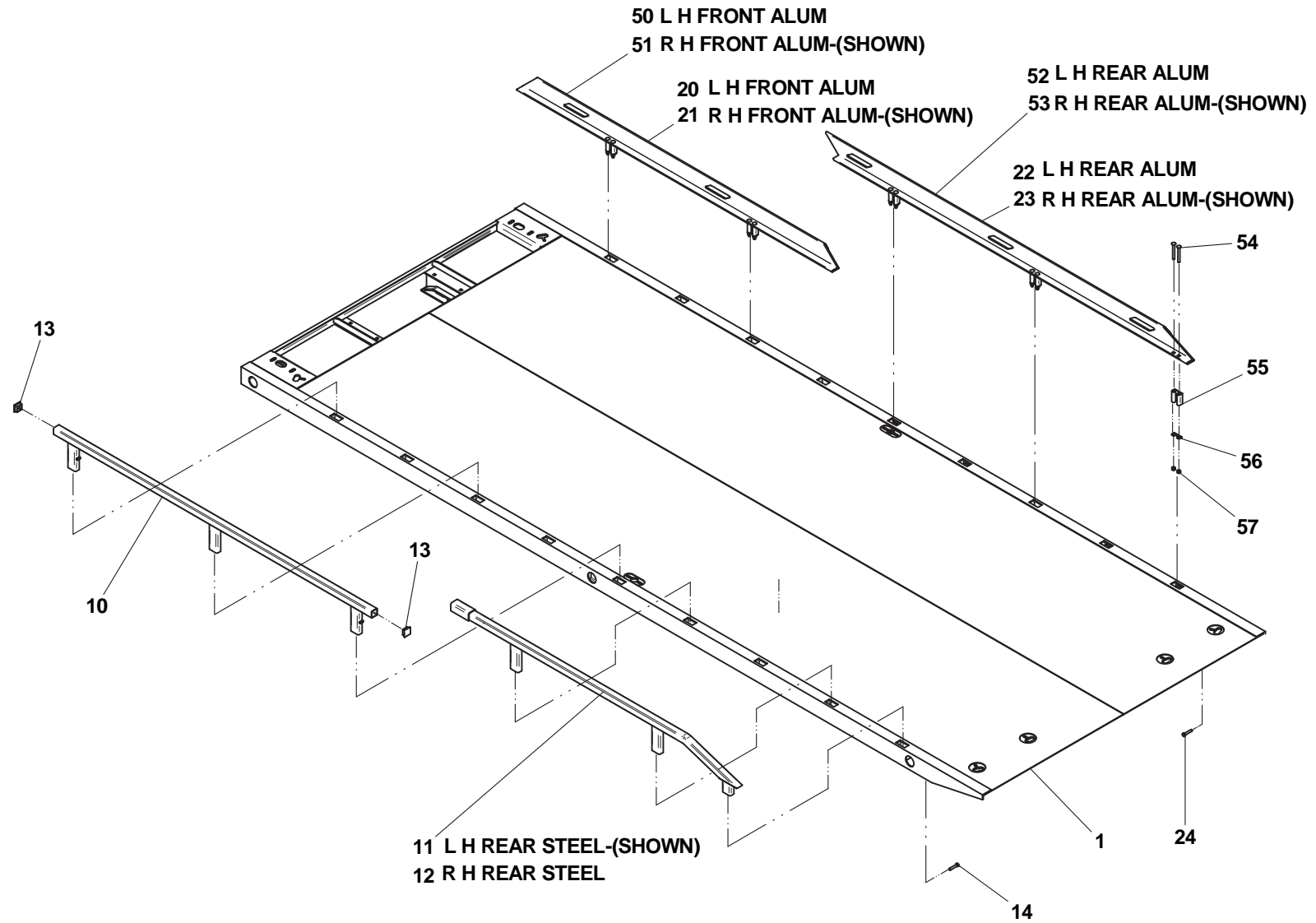

21' deck shown with standard removable steel rails on left side and optional aluminum removable rails on right side

**DECK - 5 TON STEEL B.I.C. TRANSPORTER (STRB)**

ITEM	PART NO.	DESCRIPTION	QTY	ITEM	PART NO.	DESCRIPTION	QTY
1	3097000724	19' Deck - 95" wide, 8" X-mem spacing	1			<i>Standard Steel Tubular Removable Rails:</i>	
	3097000725	19' Deck - 102" wide, 8" X-mem spacing					
	3097000726	20' Deck - 95" wide, 8" X-mem spacing		10	3017000259	Rail Weldment Front (19' & 20' decks)	2
	3097000727	20' Deck - 102" wide, 8" X-mem spacing			3017000260	Rail Weldment Front (21' deck)	
	3097000728	21' Deck - 95" wide, 8" X-mem spacing		11	3017000262	Rail Weldment Rear (19' & 20' decks)	2
	3097000729	21' Deck - 102" wide, 8" X-mem spacing			3017000261	Rail Weldment Rear (21' deck)	
2	Contact Parts	Keruing Board	A/R	12	7115181050	Capscrew, 0.50"-13NC x 1.25"	10
3	7786000007	Screw, 0.31"-18NC x 2.00"	A/R	13	7701000033	End Cap	4
						<i>Optional Aluminum Removable Rails:</i>	
				20	3017000121	Angle Assembly LH Front	1
				21	3017000122	Angle Assembly RH Front	1
				22	3017000127	Angle Assembly LH Rear (19' & 20' decks)	1
					3017000129	Angle Assembly LH Rear (21' deck)	
				23	3017000128	Angle Assembly RH Rear (19' & 20' decks)	1
					3017000130	Angle Assembly RH Rear (21' deck)	
				24	7120000005	Capscrew, 0.50"-13NC x 2.50"	10
						<i>Parts Breakdown of Angle Assemblies</i>	
				50	4017001699	Angle LH Front	1
				51	4017001700	Angle RH Front	
				52	4017001705	Angle LH Rear (19' & 20' decks)	1
					4017001707	Angle LH Rear (21' deck)	
				53	4017001706	Angle RH Rear (19' & 20' decks)	
					4017001708	Angle RH Rear (21' deck)	
				54	7115183664	Carriage Bolt, 0.50"-13NC x 4.50"	20
				55	8411080102	Extrusion	10
				56	4706006228	Plate	10
				57	7660182601	Locknut, 0.50"-13NC	20



# DECK - 5 TON STEEL B.I.C. TRANSPORTER (STRB)

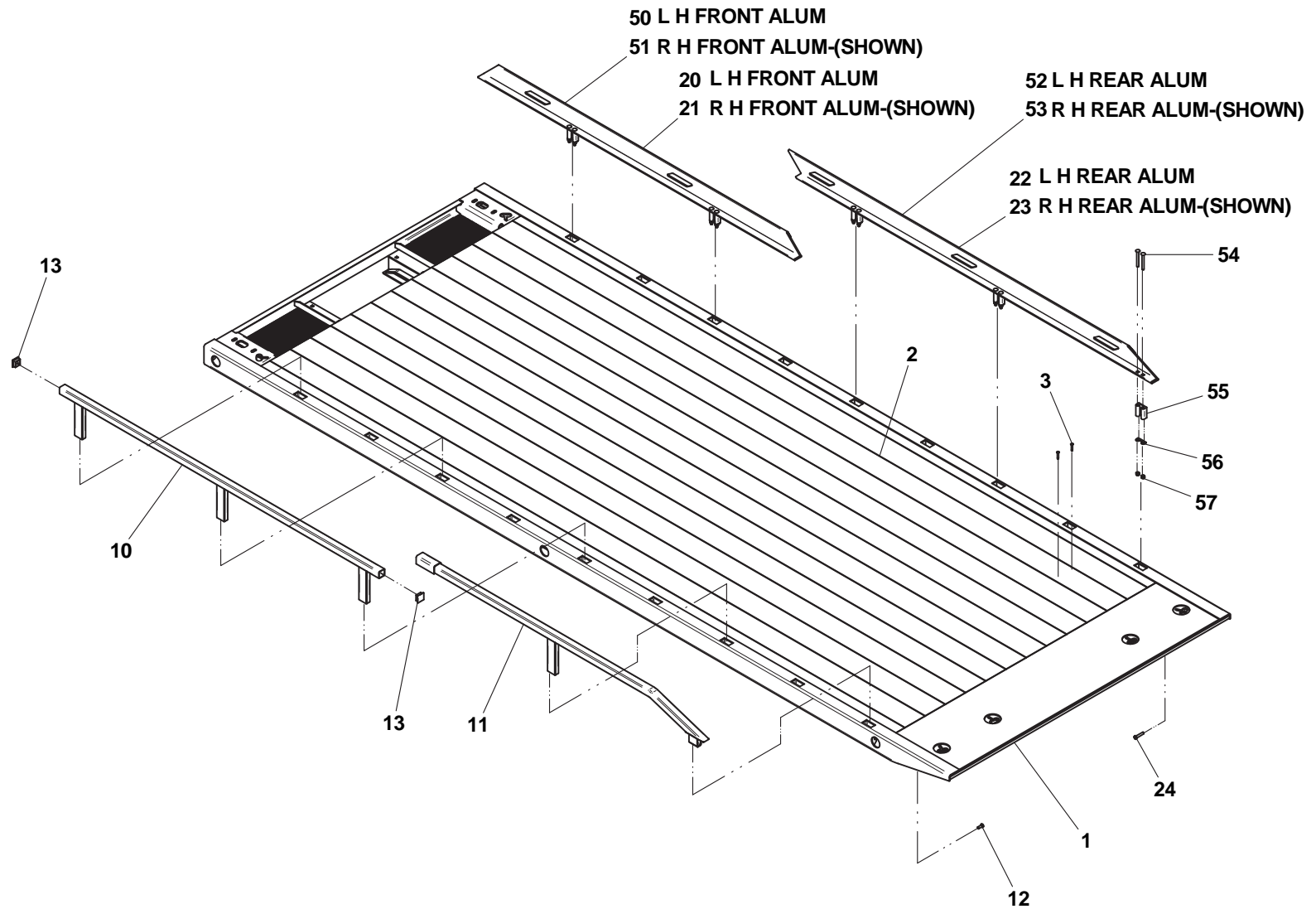

21' deck shown with optional removable steel rails on left side and optional aluminum removable rails on right side

**DECK - 6 TON PREMIUM STEEL REMOVABLE RAIL (SRR6T-W)**

ITEM	PART NO.	DESCRIPTION	QTY	ITEM	PART NO.	DESCRIPTION	QTY
1	3097000647	19' Deck , 6 Ton, 102" wide	1			<i>Standard Steel Tubular Removable Rails:</i>	
	3097000648	20' Deck , 6 Ton, 102" wide		10	3017000259	Rail Weldment Front (19' & 20' decks)	2
	3097000649	21' Deck , 6 Ton, 102" wide		11	3017000260	Rail Weldment Front (21' deck)	
					3017000262	Rail Weldment Rear (19' & 20' decks)	2
					3017000261	Rail Weldment Rear (21' deck)	
				12	7115181050	Capscrew, 0.50"-13NC x 1.25"	10
				13	7701000033	End Cap	4
						<i>Optional Aluminum Removable Rails:</i>	
				20	3017000121	Angle Assembly LH Front	1
				21	3017000122	Angle Assembly RH Front	1
				22	3017000127	Angle Assembly LH Rear (19' & 20' decks)	1
					3017000129	Angle Assembly LH Rear (21' deck)	
				23	3017000128	Angle Assembly RH Rear (19' & 20' decks)	1
					3017000130	Angle Assembly RH Rear (21' deck)	
				24	7120000005	Capscrew, 0.50"-13NC x 2.50"	10
						<i>Parts Breakdown of Angle Assemblies</i>	
				50	4017001699	Angle LH Front	1
				51	4017001700	Angle RH Front	
				52	4017001705	Angle LH Rear (19' & 20' decks)	1
					4017001707	Angle LH Rear (21' deck)	
				53	4017001706	Angle RH Rear (19' & 20' decks)	
					4017001708	Angle RH Rear (21' deck)	
				54	7115183664	Carriage Bolt, 0.50"-13NC x 4.50"	20
				55	8411080102	Extrusion	10
				56	4706006228	Plate	10
				57	7660182601	Locknut, 0.50"-13NC	20

# DECK - 6 TON PREMIUM STEEL REMOVABLE RAIL (SRR6T-W)

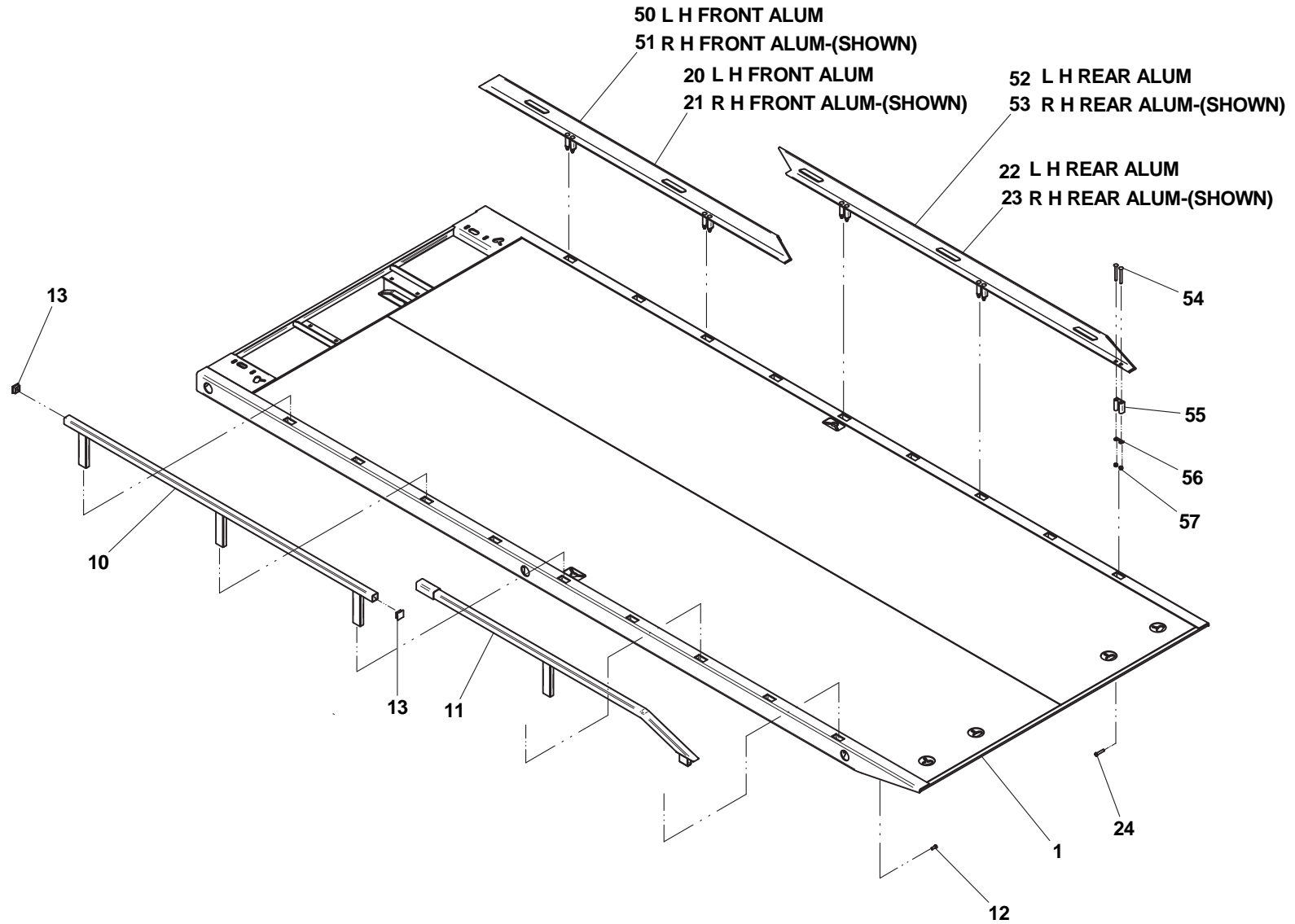

21' deck shown with standard removable steel rails on left side and optional aluminum removable rails on right side

**DECK - 6 TON PREMIUM STEEL SHARK (SRRD6T-W)**

ITEM	PART NO.	DESCRIPTION	QTY
1	3097000721	19' Deck , 6 Ton, 102" wide	1
	3097000722	20' Deck , 6 Ton, 102" wide	
	3097000723	21' Deck , 6 Ton, 102" wide	
2	3017000135	Angle Assembly LH (19' deck)	1
	3017000137	Angle Assembly LH (20' deck)	
	3017000139	Angle Assembly LH (21' deck)	
3	3017000136	Angle Assembly RH (19' deck)	1
	3017000138	Angle Assembly RH (20' deck)	
	3017000140	Angle Assembly RH (21' deck)	
4	7120000005	Capscrew, 0.50"-13NC x 2.50" (19' & 20' decks)	8
	7120000005	Capscrew, 0.50"-13NC x 2.50" (21' deck)	10
<i>Parts Breakdown of Angle Assemblies</i>			
50	4017001713	Angle LH (19' deck)	1
	4017001715	Angle LH (20' deck)	
	4017001717	Angle RH (21' deck)	
51	4017001714	Angle LH (19' deck)	1
	4017001716	Angle LH (20' deck)	
	4017001718	Angle RH (21' deck)	
52	7115183664	Carriage Bolt, 0.50"-13NC x 4.50" (19' & 20' decks)	16
	7115183664	Carriage Bolt, 0.50"-13NC x 4.50" (21' deck)	20
53	8411080102	Extrusion (19' & 20' decks)	8
		Extrusion (21' deck)	10
54	4706006228	Plate (19' & 20' decks)	8
		Plate (21' deck)	10
		7660182601	Locknut, 0.50"-13NC (19' & 20' decks)
		Locknut, 0.50"-13NC (21' deck)	20

# DECK - 6 TON PREMIUM STEEL SHARK (SRRD6T-W)

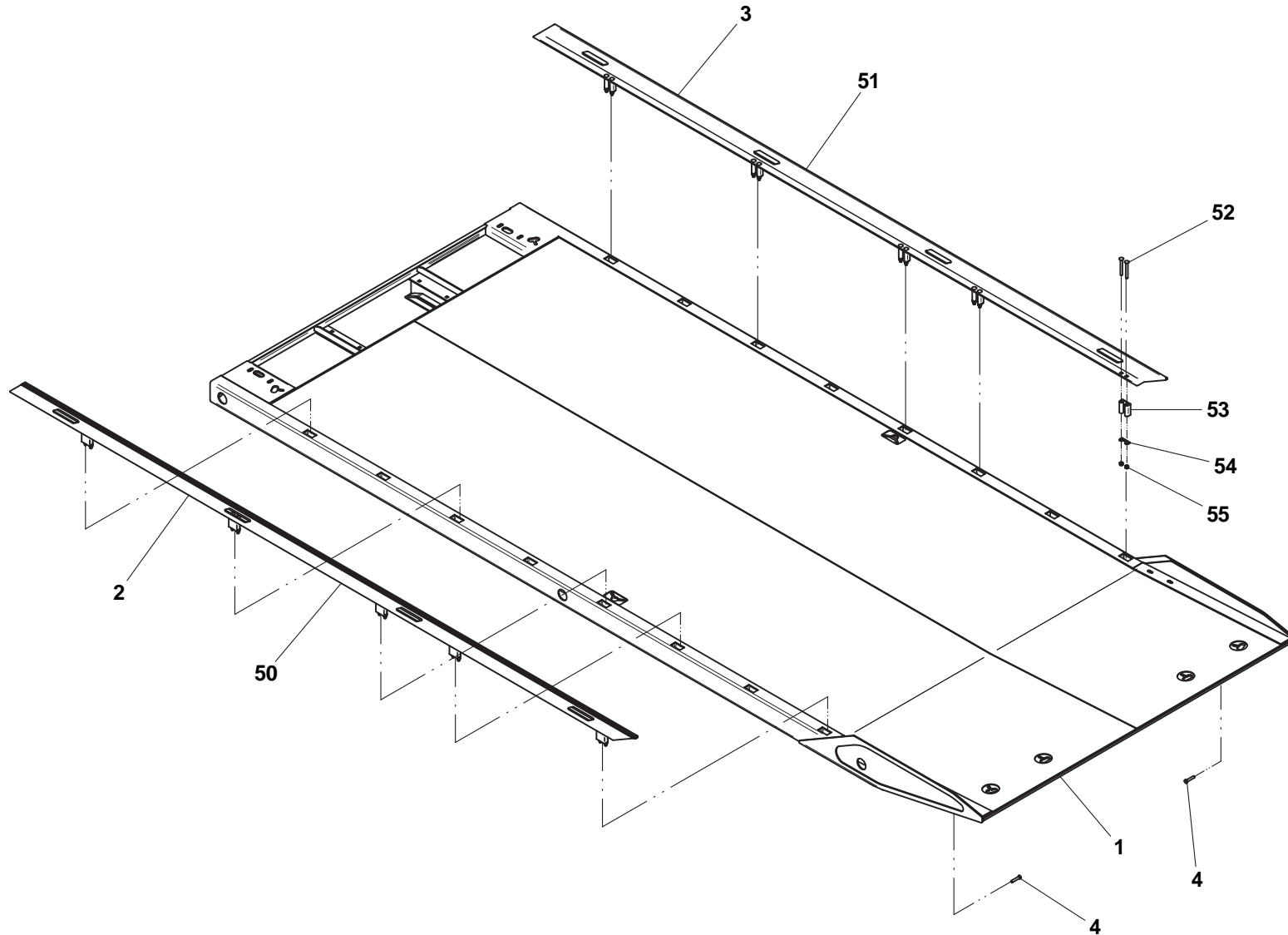

21' deck shown

**STEEL BOLT-IN KEYSLOTS**

ITEM	PART NO.	DESCRIPTION	QTY
		<i>Aluminum Decks</i>	
1	4706005551	Keyslot Plate	1
2	7115181223	Screw, 0.50"-13NC x 1.50" Flat Head	4*
3	7660182601	Locknut, 0.50"-13NC	4*
4	7950180153	Flatwasher, 0.50" ID	4*
		<i>Steel Panel Decks</i>	
1	4706005551	Keyslot Plate	1
2	7114181218	Capscrew, 0.50"-13NC x 1.50"	4*
3	7950180153	Flatwasher, 0.50" ID	4*
4	7660182601	Locknut, 0.50"-13NC	4*

\* Quantities are per Item #1

# STEEL BOLT-IN KEYSLOTS

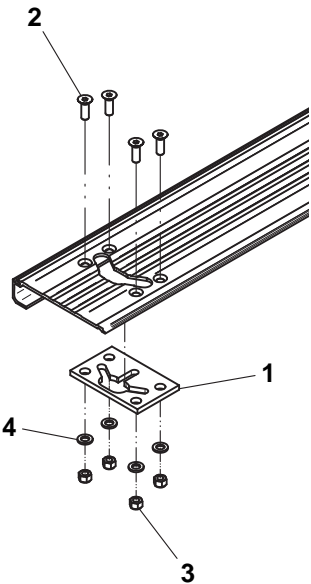

ALUMINUM DECKS

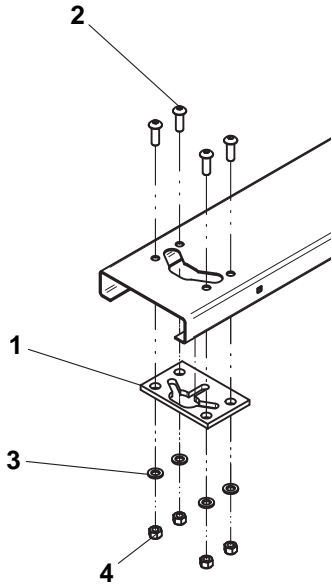
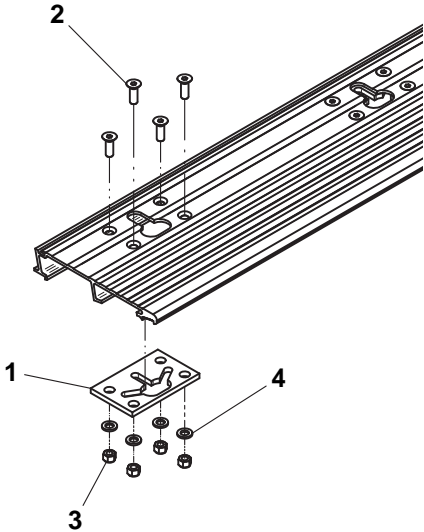

STEEL PANEL DECKS

**ADJUSTABLE ROLL CYLINDER BRACKET - DECK**

ITEM	PART NO.	DESCRIPTION	QTY
1	3017000103	Roll Cylinder Angle	1
2	7115221650	Capscrew, 0.75"-10NC x 2.00"	4
3	7660222601	Nut, 0.75"-10NC, Nyloc	4



## ADJUSTABLE ROLL CYLINDER BRACKET - DECK

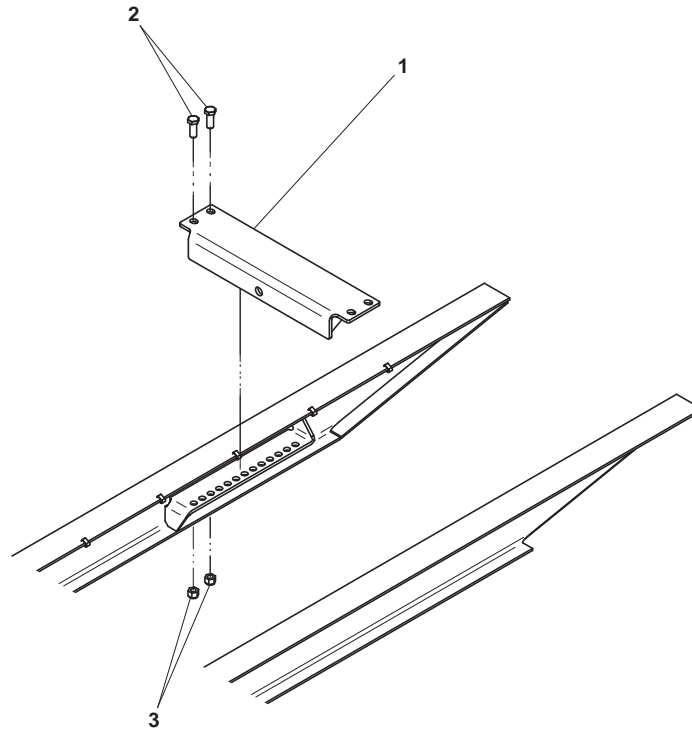

**STANDARD HEADBOARD & STANDARD WINCH FREE SPOOL**

ITEM	PART NO.	DESCRIPTION	QTY	ITEM	PART NO.	DESCRIPTION	QTY
1	3241000139	Standard Headboard Weld - 36.50" (w/ std remote free spool)	1	14	4763000348*	Rod	1
	3241000140	Standard Headboard Weld - 40.50" (w/ std remote free spool)		15	7660180234*	Nut, 0.50"-20NF	1
	3241000148	Standard Headboard Weld - 40.50" (w/ air remote free spool)		16	4178000673*	Bracket	1
	3241000141	Standard Headboard Weld - 45.50" (w/ std remote free spool)		17	7115150850*	Capscrew, 0.31"-18NC x 1.00"	2
	3241000149	Standard Headboard Weld - 45.50" (w/ air remote free spool)		18	7950150161*	Flatwasher, 0.31" ID	4
	3241000142	Standard Headboard Weld - 50.50" (w/ std remote free spool)		19	7660152601*	Locknut, 0.31"-18NC	2
	3241000150	Standard Headboard Weld - 50.50" (w/ air remote free spool)		20	4209000147*	Bushing (worm gear winch)	1
	3241000143	Standard Headboard Weld - 57.50" (w/ std remote free spool)			4209000145*	Bushing (planetary gear winch)	
	3241000151	Standard Headboard Weld - 57.50" (w/ air remote free spool)		21	7690051274*	Pin	2
2	4796000037	Gasket	2	22	7949000030*	Nylon Washer	1
3	7105201650	Capscrew, 0.63"-18NF x 2.00"	4	23	7843000027*	Spring	1
4	7950200152	Flatwasher, 0.63" ID	4	24	7551000017*	Knob	1
5	7660200035	Nut, 0.63"-18NF	2	25	4632000009*	Trim Lok	1
6	4587000004*	Lever	1				
7	4209000328*	Bushing	1				
8	7082000010*	Nylon Washer	2				
9	7950180161*	Flatwasher, 0.50" ID	1				
10	7309000002*	Coupling	1				
11	7691000046*	Clevis Pin	1				
12	7660182631*	Locknut, 0.50"-20NF	1				
13	7950180143*	Flatwasher, 0.50" ID	2				

\* also available in complete Remote Free Spool Installation:  
P/N 2970000021 for 8,000 / 10,000 lb worm gear winch  
P/N 2970000019 for 8,000 lb planetary gear winch

## STANDARD HEADBOARD & STANDARD WINCH FREE SPOOL

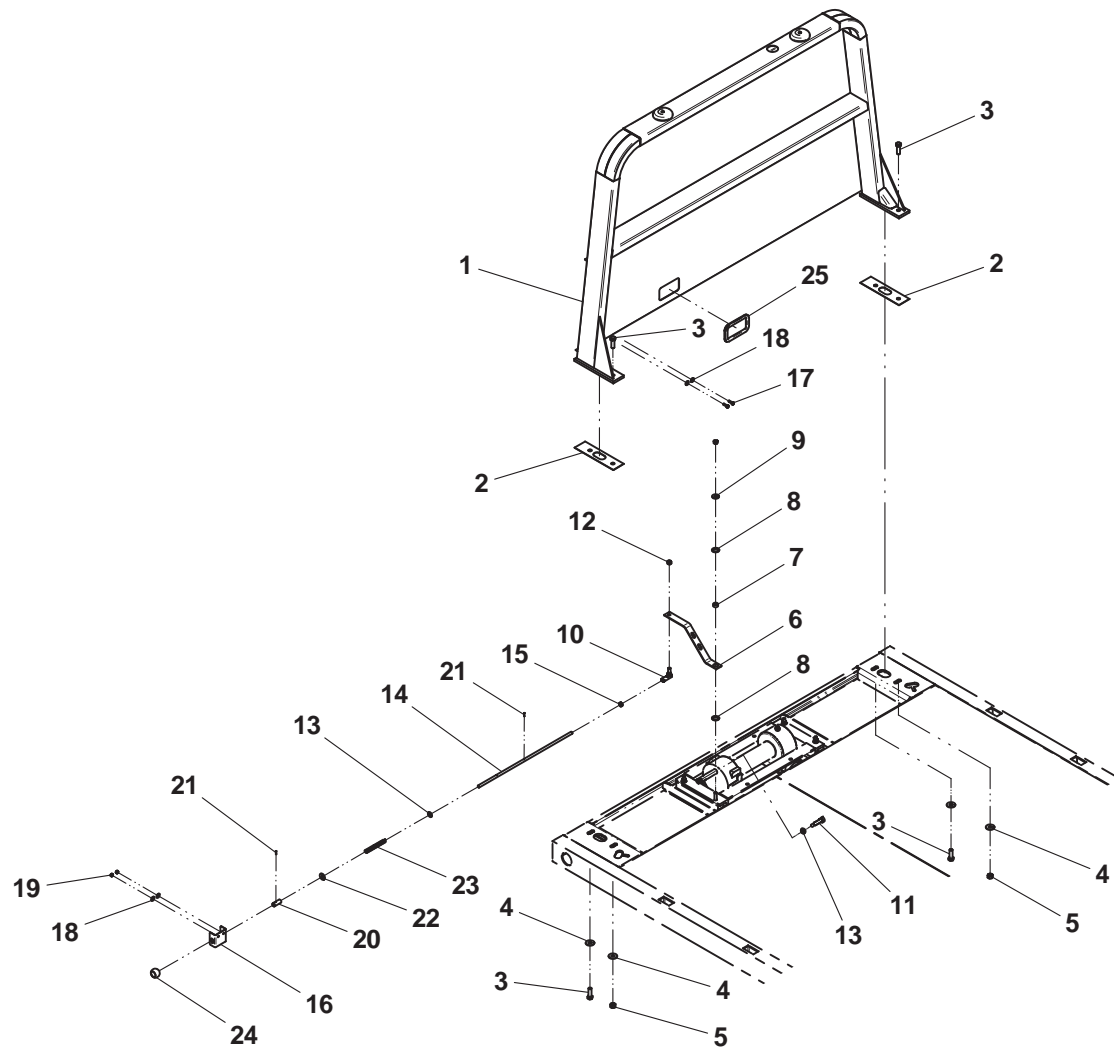

50.50" headboard shown with 8,000 lb worm gear winch and standard remote free spool

**DELUXE HEADBOARD & STANDARD WINCH FREE SPOOL**

ITEM	PART NO.	DESCRIPTION	QTY	ITEM	PART NO.	DESCRIPTION	QTY
1	3241000132	Deluxe Headboard Weld - 36.50" (w/ std remote free spool)	1	13	7309000002*	Coupling	1
	3241000133	Deluxe Headboard Weld - 40.50" (w/ std remote free spool)		14	7691000046*	Clevis Pin	1
	3241000144	Deluxe Headboard Weld - 40.50" (w/ air remote free spool)		15	7660182631*	Locknut, 0.50"-20NF	1
	3241000134	Deluxe Headboard Weld - 45.50" (w/ std remote free spool)		16	7950180143*	Flatwasher, 0.50" ID	2
	3241000145	Deluxe Headboard Weld - 45.50" (w/ air remote free spool)		17	4763000348*	Rod	1
	3241000135	Deluxe Headboard Weld - 50.50" (w/ std remote free spool)		18	7660180234*	Nut, 0.50"-20NF	1
	3241000146	Deluxe Headboard Weld - 50.50" (w/ air remote free spool)		19	4178000673*	Bracket	1
	3241000136	Deluxe Headboard Weld - 57.50" (w/ std remote free spool)		20	7115150850*	Capscrew, 0.31"-18NC x 1.00"	2
	3241000147	Deluxe Headboard Weld - 57.50" (w/ air remote free spool)		21	7950150161*	Flatwasher, 0.31" ID	4
				22	7660152601*	Locknut, 0.31"-18NC	2
				23	4209000147*	Bushing (worm gear winch)	1
					4209000145*	Bushing (planetary gear winch)	
				24	7690051274*	Pin	2
				25	7949000030*	Nylon Washer	1
				26	7843000027*	Spring	1
				27	7551000017*	Knob	1
				28	4632000009*	Trim Lok	1
2	4796000037	Gasket	2				
3	7105201650	Capscrew, 0.63"-18NF x 2.00"	4				
4	7950200152	Flatwasher, 0.63" ID	4				
5	7660200035	Nut, 0.63"-18NF	2				
6	3391000014	Screen Weld (36.50", 40.50" & 45.50" headboards)	1				
	3391000017	Screen Weld (50.50" headboard)					
	3391000018	Screen Weld (57.50" headboard)					
7	4796000003	Gasket	1				
8	7759000015	Rivet	6				
9	4587000004*	Lever	1				
10	4209000328*	Bushing	1				
11	7082000010*	Nylon Washer	2				
12	7950180161*	Flatwasher, 0.50" ID	1				

\* also available in complete Remote Free Spool Installation:  
P/N 2970000021 for 8,000 / 10,000 lb worm gear winch  
P/N 2970000019 for 8,000 lb planetary gear winch

# DELUXE HEADBOARD & STANDARD WINCH FREE SPOOL

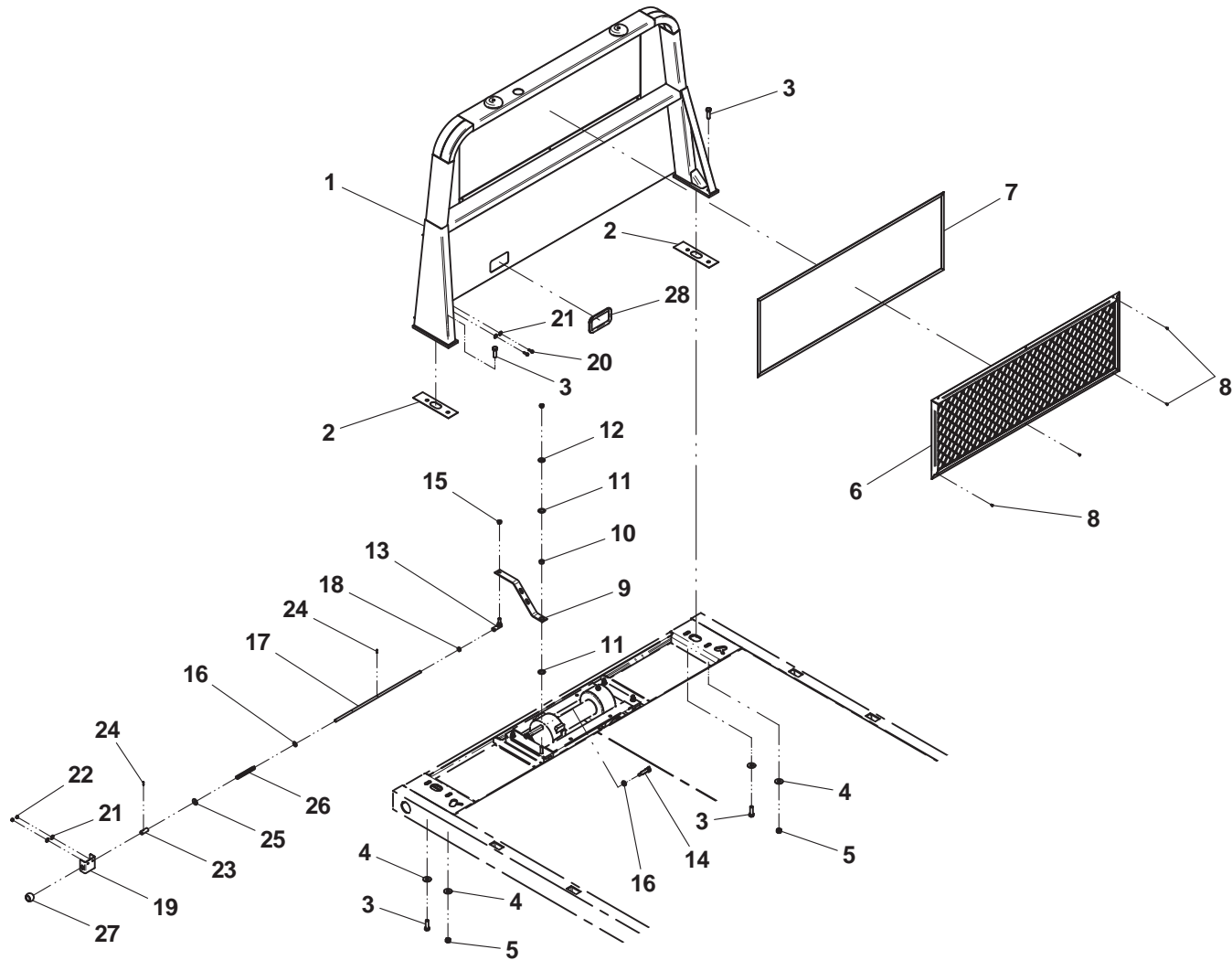

50.50" headboard shown with 8,000 lb worm gear winch and standard remote free spool

**MODULAR HEADBOARD**

ITEM	PART NO.	DESCRIPTION	QTY
1	3241000232	Modular Headboard Weld - 36.50" (w/ std remote free spool)	1
	3241000235	Modular Headboard Weld - 36.50" (w/ air remote free spool)	
	3241000231	Modular Headboard Weld - 40.50" (w/ std remote free spool)	
	3241000234	Modular Headboard Weld - 40.50" (w/ air remote free spool)	
	3241000218	Modular Headboard Weld - 45.50" (w/ std remote free spool)	1
	3241000223	Modular Headboard Weld - 45.50" (w/ air remote free spool)	
	3241000230	Modular Headboard Weld - 50.50" (w/ std remote free spool)	1
	3241000233	Modular Headboard Weld - 50.50" (w/ air remote free spool)	
	3241000217	Modular Headboard Weld - 57.50" (w/ std remote free spool)	1
	3241000222	Modular Headboard Weld - 57.50" (w/ air remote free spool)	
2	4796000037	Gasket	2
3	7105201650	Capscrew, 0.63"-18NF x 2.00"	4
4	7950200152	Flatwasher, 0.63" ID	4
5	7660200035	Nut, 0.63"-18NF	2
6	7115160850	Capscrew, 0.38"-16NC x 1.00"	4
7	7790161253	Capscrew, 0.38"-16NC X .75"	4
8	4178000808	Bracket	2
9	4263000817	Headboard Channel	1
10	7660162601	Locknut, 0.38"-16NC	4
11	7950160161	Flatwasher, 0.38" ID	8

# MODULAR HEADBOARD

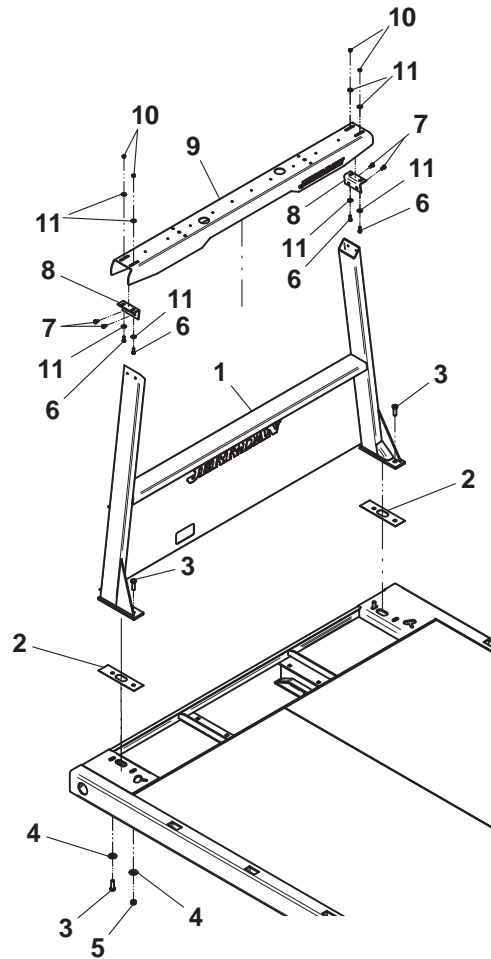

50.50" headboard shown with 8,000 lb worm gear winch and standard remote free spool

**BUCKET REST HEADBOARD**

ITEM	PART NO.	DESCRIPTION	QTY
1	3636000078	Lightbar Mount	2
2	7115161050	Capscrew, 0.38"-16NC x 1.25"	4
3	7660161600	Locknut, 0.38"-16NC	4
4	7950160160	Flatwasher, 0.38" ID	4



# BUCKET REST HEADBOARD

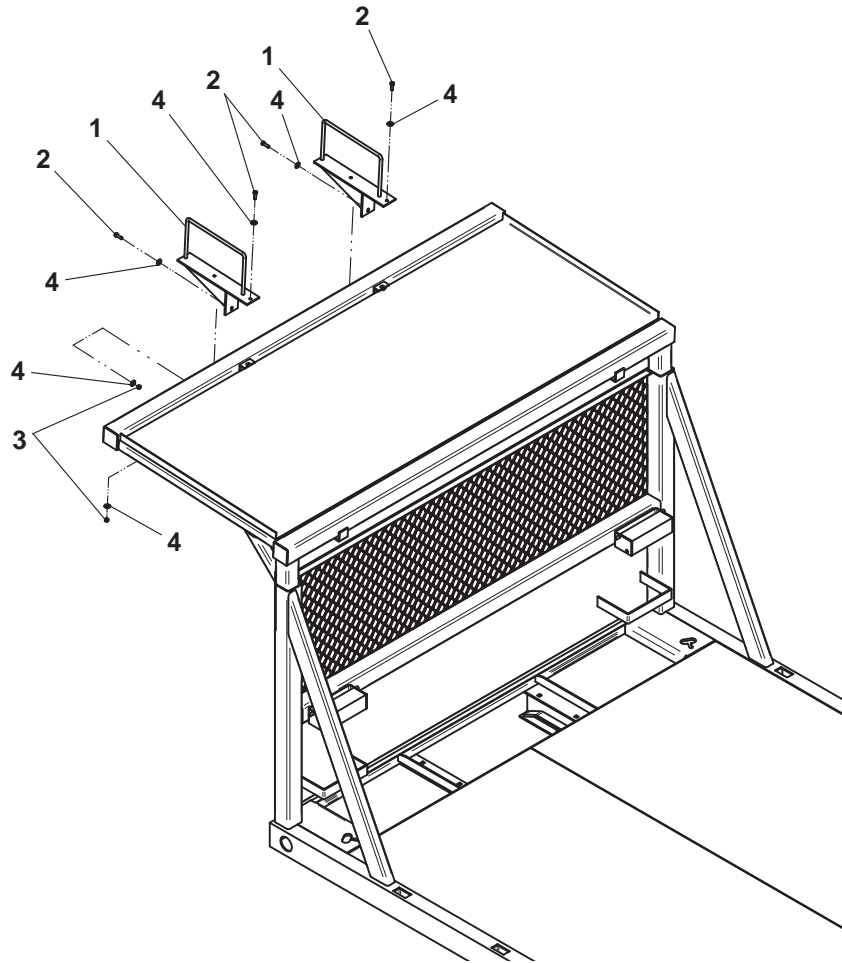

**STATIONARY HEADBOARD & STANDARD WINCH FREE SPOOL**

ITEM	PART NO.	DESCRIPTION	QTY	ITEM	PART NO.	DESCRIPTION	QTY
1	3241000161	Stationary Headboard Weld - 57.00"	1	26	7690051274*#	Pin	2
	3241000162	Stationary Headboard Weld - 62.00"		27	7949000030*#	Nylon Washer	1
	3241000163	Stationary Headboard Weld - 69.00"		28	7843000027*#	Spring	1
2	7105181650	Capscrew, 0.50"-20NF x 2.00"	8	29	7551000017*#	Knob	1
3	7950180153	Flatwasher, 0.50" ID	8				
4	7660182333	Locknut, 0.50"-20NF	8				
5	3391000014	Screen Weld (57.00" headboard)	1				
	3391000017	Screen Weld (62.00" headboard)					
	3391000018	Screen Weld (69.00" headboard)					
6	4796000003	Gasket	1				
7	7759000015	Rivet	6				
8	4705000607	Shim - 0.25"	A/R				
9	4705000608	Shim - 0.12"	A/R				
10	4587000005*#	Lever	1				
11	4209000328*#	Bushing	1				
12	7082000010*#	Nylon Washer	2				
13	7950180161*#	Flatwasher, 0.50" ID	1				
14	7309000002*#	Coupling	1				
15	7691000046*#	Clevis Pin	1				
16	7660182631*#	Locknut, 0.50"-20NF	1				
17	7950180143*#	Flatwasher, 0.50" ID	2				
18	4763000348*#	Rod	1				
19	7660180234*#	Locknut, 0.50"-20NF	1				
20	4178000674*	Bracket (steel decks)	1				
	4017001499#	Bracket (aluminum decks)					
21	4178000673*#	Bracket	1				
22	7115150850*#	Capscrew, 0.31"-18NC x 1.00"	2				
23	7950150161*#	Flatwasher, 0.31" ID	4				
24	7660152601*#	Locknut, 0.31"-18NC	2				
25	4209000147*#	Bushing (worm gear winch)	1				
	4209000145*#	Bushing (planetary gear winch)					

# also available in complete Remote Free Spool Installation - aluminum deck :  
 P/N 2970000053 for 8,000 / 10,000 lb worm gear winch  
 P/N 2970000051 for 8,000 lb planetary gear winch

\* also available in complete Remote Free Spool Installation - steel deck:  
 P/N 2970000052 for 8,000 / 10,000 lb worm gear winch  
 P/N 2970000050 for 8,000 lb planetary gear winch

# STATIONARY HEADBOARD & STANDARD WINCH FREE SPOOL

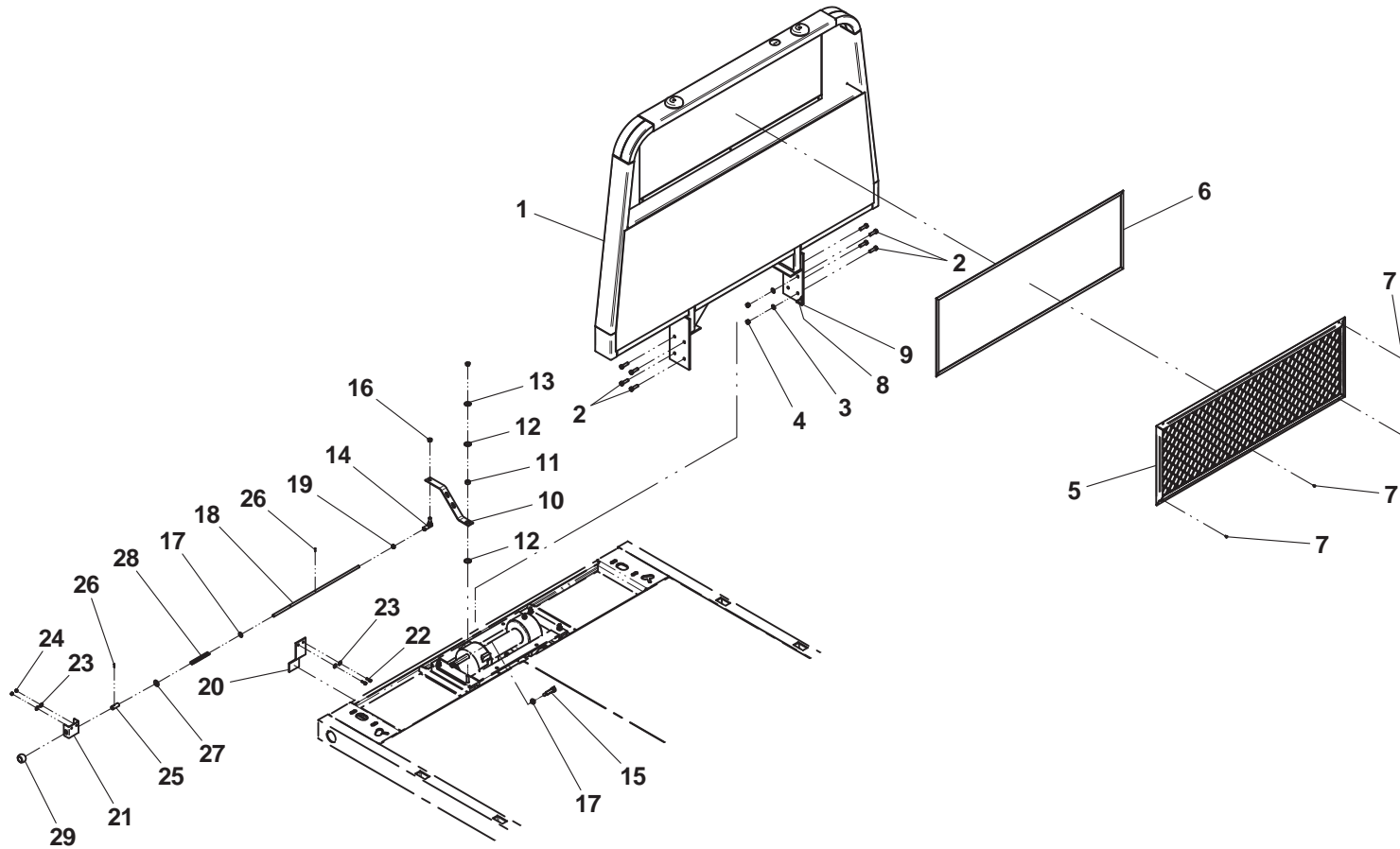

62.00" headboard shown with 8,000 lb worm gear winch

**WORM GEAR WINCH**

ITEM	PART NO.	DESCRIPTION	QTY
1	7970000121	Winch - 8,000 lb Worm Gear (w/ std remote free spool)	1
	7970000142	Winch - 8,000 lb Worm Gear (w/ air remote free spool)	
	7970000123	Winch - 10,000 lb Worm Gear (w/ std remote free spool)	
	7970000140	Winch - 10,000 lb Worm Gear (w/ air remote free spool)	
2	7626000014	Orbit Motor	1
3	7115181250	Capscrew, 0.50"-13NC x 1.50"	2
4	7950180400	Lockwasher, 0.50" ID	2
5	7115181464	Carriage Bolt, 0.50"-13NC x 1.75" (steel decks)	3
	7115182864	Carriage Bolt, 0.50"-13NC x 3.5" (steel transporters)	
	7115181864	Carriage Bolt, 0.50"-13NC x 2.25" (aluminum decks)	
	7115183264	Carriage Bolt, 0.50"-13NC x 4.00" (aluminum transporters)	
6	7115181864	Carriage Bolt, 0.50"-13NC x 2.25" (steel decks)	1
	7115183264	Carriage, 0.50"-13NC x 4.00" (steel transporters)	
	7115182264	Carriage Bolt, 0.50"-13NC x 2.75" (aluminum decks)	
	7115183664	Capscrew, 0.50"-13NC x 4.50" (aluminum transporters)	
7	7950180153	Flatwasher, 0.50" ID	4
8	7660182601	Locknut, 0.50"-13NC	4
9	4062000318	Bar (transporters only)	2
10	7248000063	Cable, 0.38" dia x 56' (8,000lb winch)	1
	7248000064	Cable, 0.44" dia x 56' (10,000lb winch)	

Refer to manufacturer's manual for winch parts list

# WORM GEAR WINCH

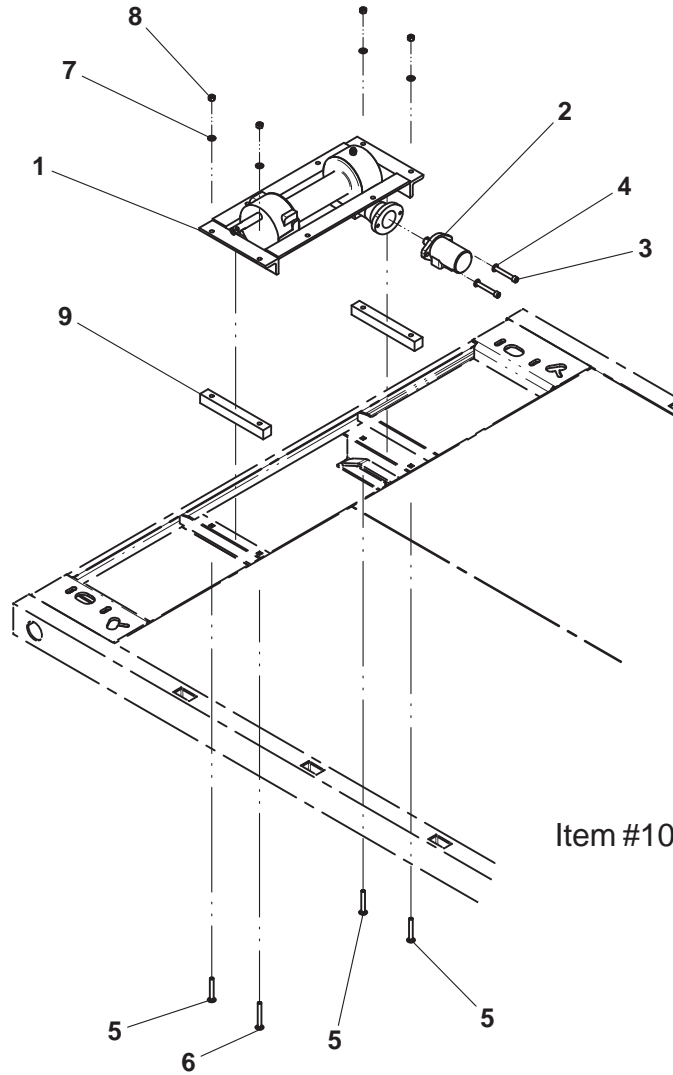

Item #10, Winch Cable, not shown

8,000 lb winch shown on transporter deck

**PLANETARY GEAR WINCH**

ITEM	PART NO.	DESCRIPTION	QTY
1	7970000056	Winch - 8,000 lb Planetary Gear (w/ std remote free spool)	1
2	7115181464	Carriage Bolt, 0.50"-13NC x 1.75" (steel decks)	3
	7115182864	Carriage Bolt, 0.50"-13NC x 3.50" (steel transporters)	
	7115181864	Carriage Bolt, 0.50"-13NC x 2.25" (aluminum decks)	
	7115183264	Carriage Bolt, 0.50"-13NC x 4.00" (aluminum transporters)	
3	7115181864	Carriage Bolt, 0.50"-13NC x 2.25" (steel decks)	1
	7115183264	Carriage, 0.50"-13NC x 4.00" (steel transporters)	
	7115182264	Carriage Bolt, 0.50"-13NC x 2.75" (aluminum decks)	
	7115183664	Capscrew, 0.50"-13NC x 4.50" (aluminum transporters)	
4	7950180153	Flatwasher, 0.50" ID	4
5	7660182601	Locknut, 0.50"-13NC	4
6	4062000318	Bar (transporters only)	2
7	7248000063	Cable, 0.38" dia x 56'	1

Refer to manufacturer's manual for winch parts list

# PLANETARY GEAR WINCH

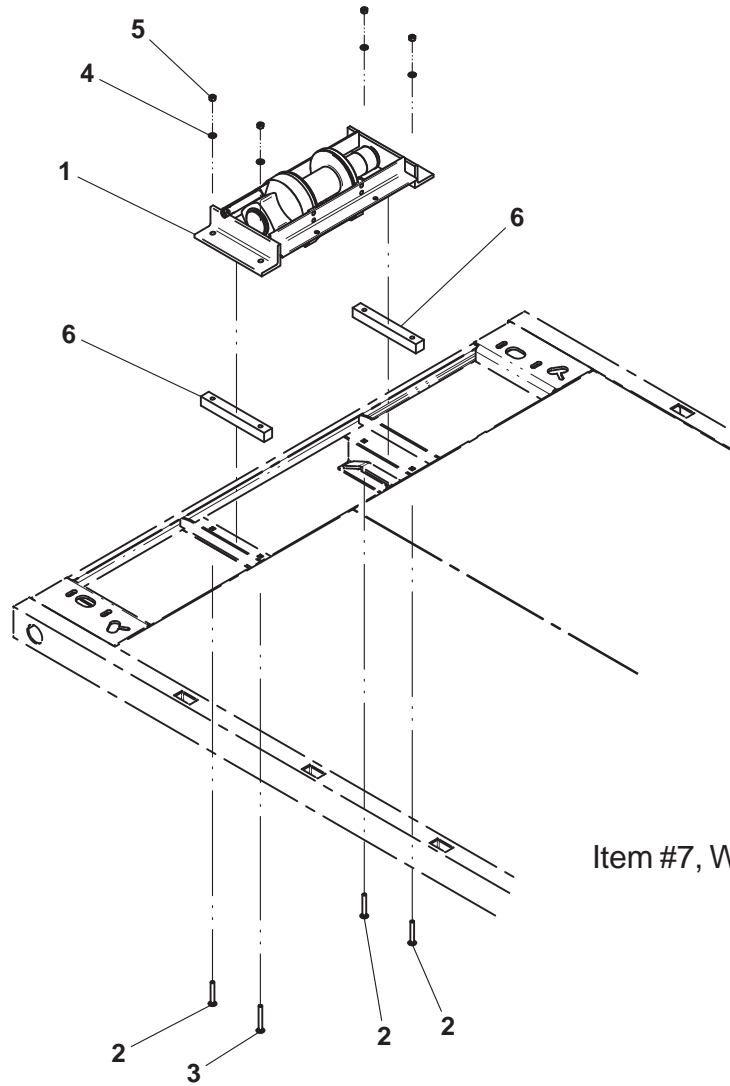

Item #7, Winch Cable, not shown

8,000 lb winch shown on transporter deck

**WORM GEAR WINCH CABLE ROLLER GUIDE / TENSIONER PLATE**

ITEM	PART NO.	DESCRIPTION	QTY
1	3178000433*	Bracket Weld	1
2	7115181464	Carriage Bolt, 0.50"-13NC x 1.75"	4
3	7950180153	Flatwasher, 0.50" ID	4
4	7660182601	Locknut, 0.50"-13NC	4
5	4706003766	Plate	1
6	7843000035	Spring	2
7	4912000130*	Roller	1
8	4806000014*	Shaft	1
9	4912000394*	Roller	2
10	4806000011*	Shaft	2
11	7209000011*	Bushing	6
12	7949000034*	Spacer	4
13	7754000022*	Retaining Ring	6

\* also available in Cable Guide / Tensioner Assembly, P/N 3249000036



# WORM GEAR WINCH CABLE ROLLER GUIDE / TENSIONER PLATE

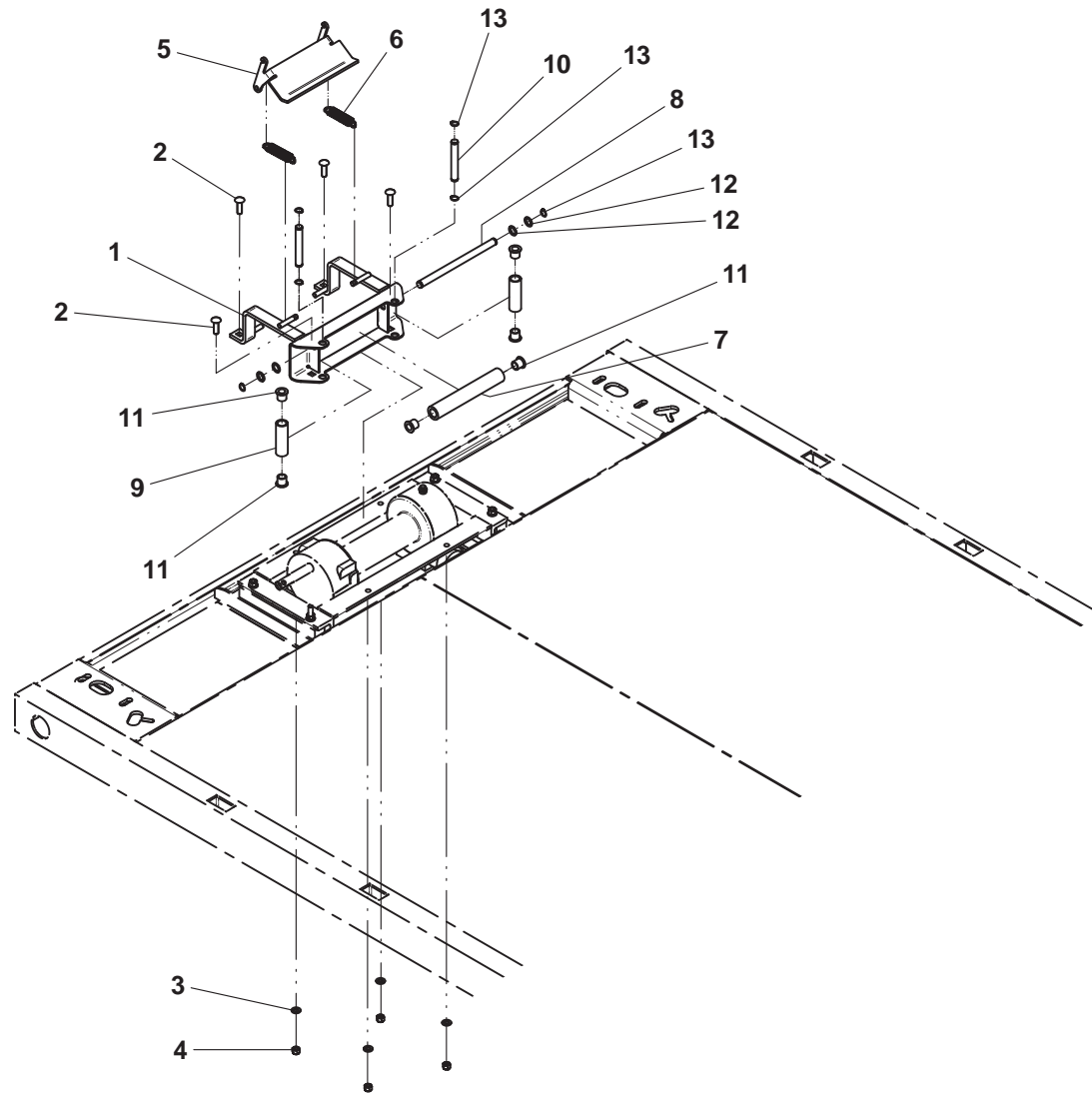

8,000 lb winch shown

**PLANETARY GEAR WINCH CABLE ROLLER GUIDE / TENSIONER PLATE**

ITEM	PART NO.	DESCRIPTION	QTY
1	3178000347	Bracket Weld	1
2	7115181050	Capscrew, 0.50"-13NC x 1.25"	2
3	7115180850	Capscrew, 0.50"-13NC x 1.00"	4
4	7950180153	Flatwasher, 0.50" ID	6
5	4706003792	Plate	1
6	7843000035	Spring	2
7	4912000345*	Roller	1
8	4691000421*	Shaft	1
9	7209000011*	Bushing	2
10	7949000034*	Spacer	2
11	7754000022*	Retaining Ring	2

\* also available in Cable Guide / Tensioner Assembly, P/N 3249000019

# PLANETARY GEAR WINCH CABLE ROLLER GUIDE / TENSIONER PLATE

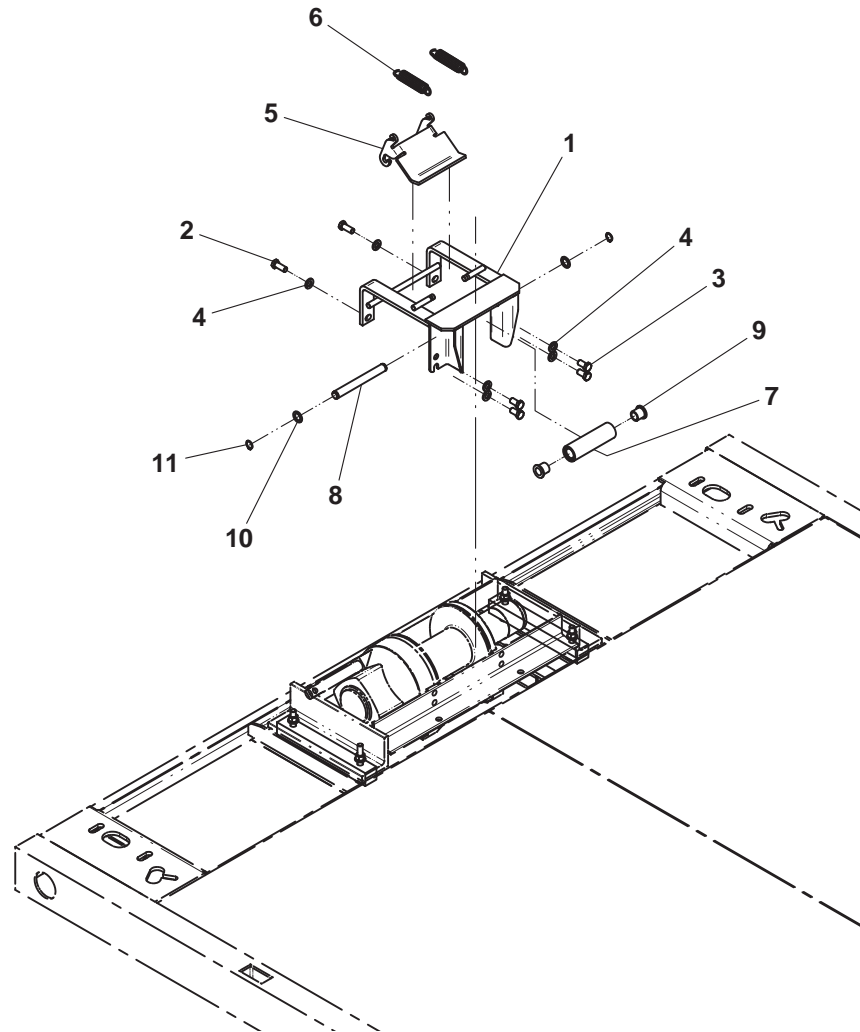

8,000 lb winch shown

**REMOTE AIR FREE SPOOL**

ITEM	PART NO.	DESCRIPTION	QTY
1	7565000014	Air line Tubing	*
2	7935000182	Air Valve	2
3	7443000364	Fitting	5
4	7640000002	Air Exhaust Muffler	2
5	7443000154	Fitting	1
6	7443000111	Fitting	1
7	7443000156	Nipple	2
8	7935000120	Pressure Protection Valve	1
9	7443000152	Plug	1
10	7443000366	Fitting	1
11	7935000248	Air Regulator	1
12	7443000371	Tee	1
13	7443000365	Fitting	2
14	8597650001	Loom	*
15	7935000229	Shuttle Valve	1
16	7894000004	Tie Strap	*
17	7443000443	Union	1
18	7565000016	Airline Tubing	*

\* - Quantity varies depending on deck length and chassis

# REMOTE AIR FREE SPOOL

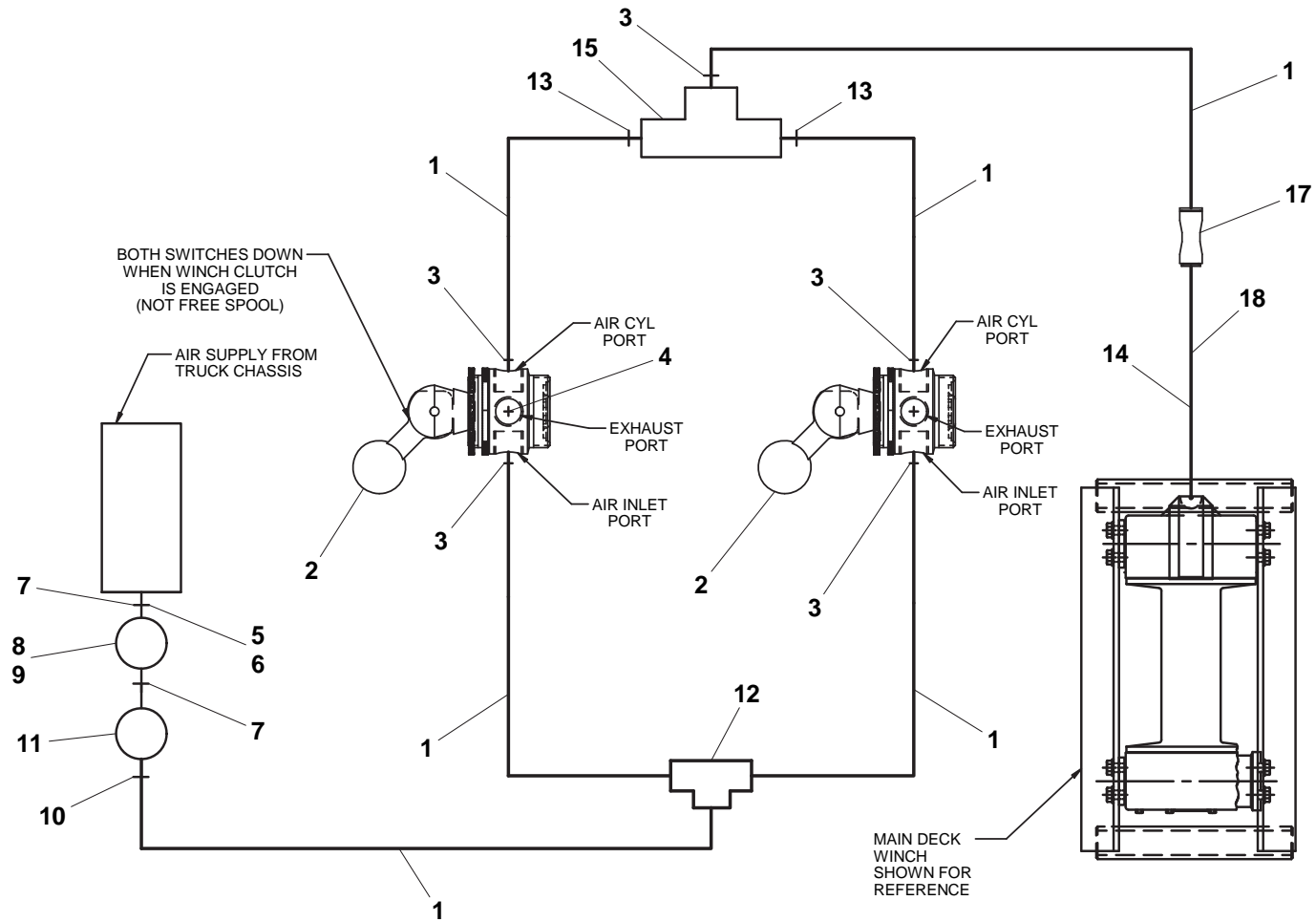

Item #16, Tie Strap, not shown

**SUBFRAME (OUTBOARD TILT CYLINDERS)**

ITEM	PART NO.	DESCRIPTION	QTY	ITEM	PART NO.	DESCRIPTION	QTY
1	3868000300	Subframe Weld - Standard	1	23	7105181650	Capscrew, 0.50"-20NF x 2.00" (5 Ton)	8
	3868000301	Subframe Weld - Galvanized			7105201850	Capscrew, 0.63"-18NF x 2.25" (6 Ton)	8
2	3905000012	Trunnion Weld	1	24	7950180153	Flatwasher, 0.50 ID (5 Ton)	8
3	4497000358	Gusset	2		7950200242	Flatwasher, 0.63 ID (6 Ton)	8
	4497000549	Gusset (Dodge 5500 & Ford F550 only)		25	7660182333	Locknut, 0.50"-20NF (5 Ton)	8
4	7082000017*	Bearing	4		7660202347	Locknut, 0.63"-18NF (6 Ton)	8
5	4691000573	Pin	2	26	3178000234*	Light Box, RH	1
6	7949000008	Washer, 2.25" ID	2	27	3178000233*	Light Box, LH	1
7	7115162450	Capscrew, 0.38"-16NC x 3.00"	2	28	4017001294*	Mud Flap Angle, RH	1
8	7660162601	Locknut, 0.38"-16NC	6	29	4017001293*	Mud Flap Angle, LH	1
9	4178000804	Bracket (5-Ton)	2	30	7115180650	Capscrew, 0.50"-13NF x 0.75"	2
	4178000805	Bracket (6-Ton)		31	4062000281	Plate (Dodge Ram 5500)	2
10	3320000113	Tilt Cylinder Assembly (5 Ton)	2	32	7949000072	Washer, 0.50 ID	2
	3320000122	Tilt Cylinder Assembly (6 Ton)		33	4209000358	Bushing	2
11	3691000166	Pin Weld (5 Ton)	4				
	3691000166	Pin Weld (6 Ton)	2				
12	3691000273	Pin Weld (6 Ton)	2				
13	4209000337	Bushing (5 Ton)	12				
	4209000337	Bushing (6 Ton)	8				
14	7115161050	Capscrew, 0.38"-16NC x 1.25"	4				
15	3320000236	Roll Cylinder Assembly	1				
16	4691000429	Pin	1				
17	7754000006	Retaining Ring	2				
18	4679000151	Pad	1				
19	4178000367	Bracket	1				
20	7660182601	Locknut, 0.50"-13NC	2				
21	7701000048*	Plug	4				
22	7701000051*	Plug	6				

\* included in Subframe Weld, P/N 3868000300

# SUBFRAME (OUTBOARD TILT CYLINDERS)

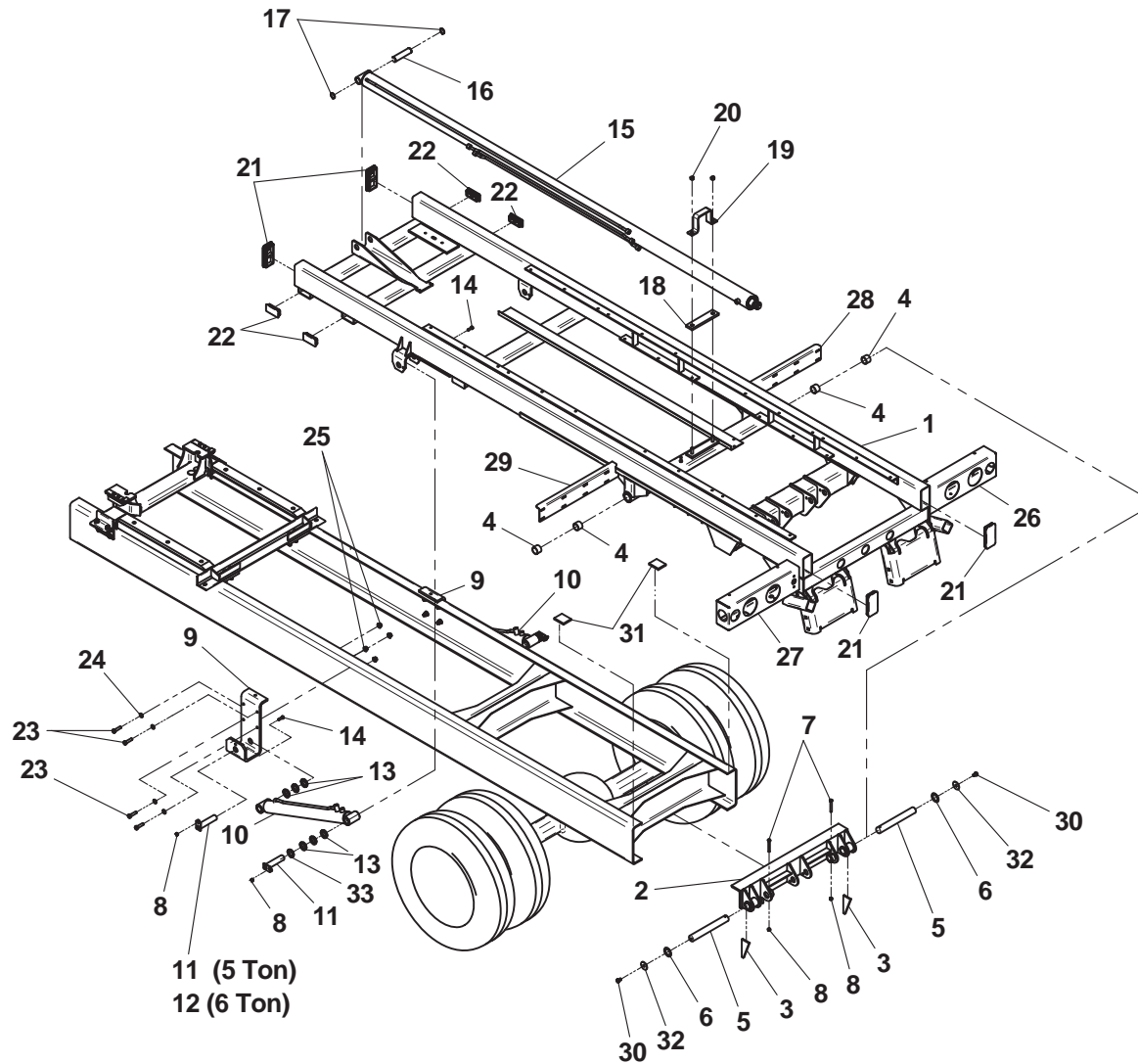

standard subframe weldment shown

**SUBFRAME (INBOARD TILT CYLINDERS)**

ITEM	PART NO.	DESCRIPTION	QTY
1	3868000302	Subframe Weld - Standard	1
	3868000311	Subframe Weld - Galvanized	
2	3905000012	Trunnion Weld	1
3	4497000358	Gusset	2
4	7082000017*	Bearing	4
5	4691000573	Pin	2
6	7949000008	Washer, 2.25" ID	2
7	7115162450	Capscrew, 0.38"-16NC x 3.00"	2
8	7660162601	Locknut, 0.38"-16NC	6
9	3316000054	Crossmember Weld	1
10	3320000120	Tilt Cylinder Assembly	2
11	3691000073	Pin Weld	4
12	7115160950	Capscrew, 0.38"-16NC x 1.12"	4
13	3320000236	Roll Cylinder Assembly	1
14	4691000429	Pin	1
15	7754000006	Retaining Ring	2
16	4679000151	Pad	1
17	4178000367	Bracket	1
18	7660182601	Locknut, 0.50"-13NC	2
19	7701000048*	Plug	4
20	7701000051*	Plug	2
21	7105181650	Capscrew, 0.50"-20NF x 2.00"	8
22	7950180153	Flatwasher, 0.50 ID	8
23	7660182333	Locknut, 0.50"-20NF	8
24	3178000234*	Light Box, RH	1
25	3178000233*	Light Box, LH	1
26	4017001294*	Mud Flap Angle, RH	1
27	4017001293*	Mud Flap Angle, LH	1
28	4062000281	Bar (UD 1800/2000/2300)	4
29	7949000072	Washer, 0.50 ID	2
30	7115180650	Capscrew, 0.50"-13NF x 0.75"	2

\* included in Subframe Weld, P/N 3868000302



# SUBFRAME (INBOARD TILT CYLINDERS)

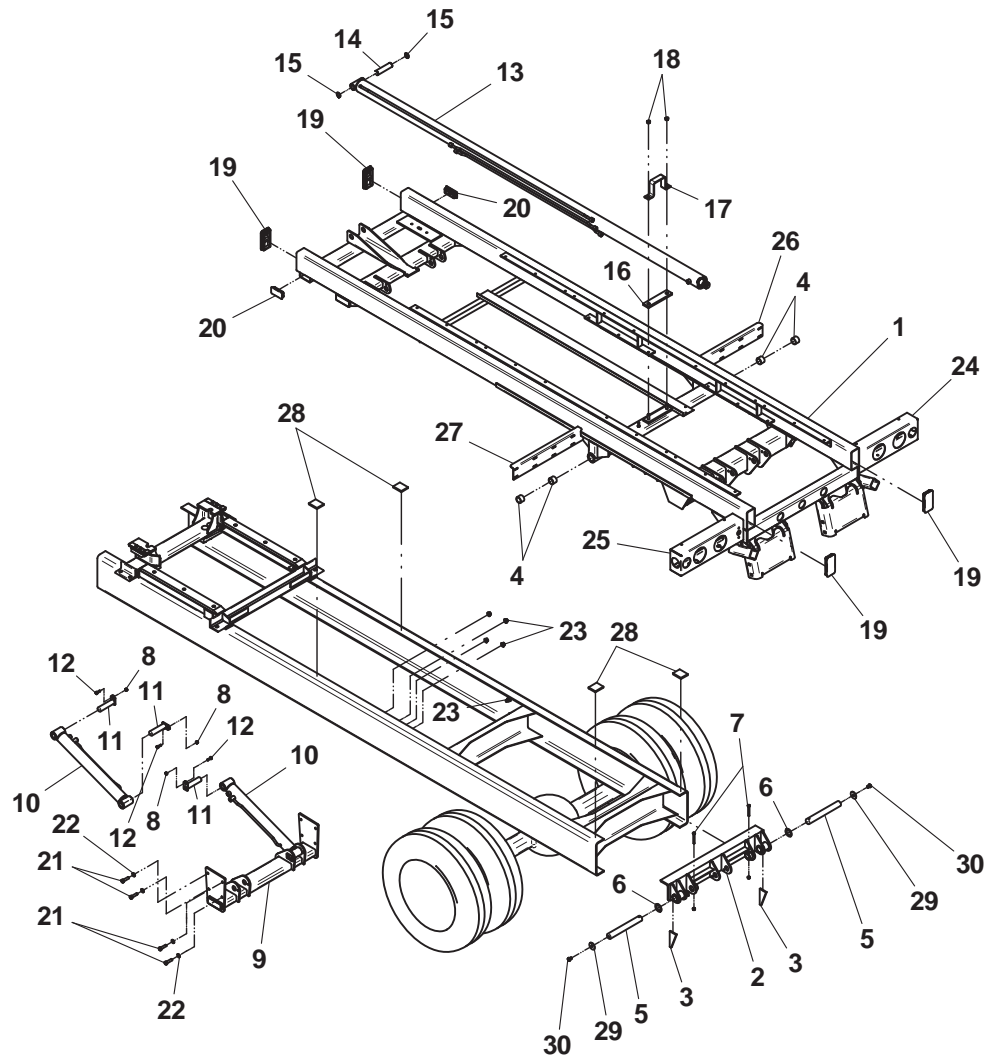

**HOLD DOWN (OUTBOARD TILT CYLINDERS)**

ITEM	PART NO.	DESCRIPTION	QTY
1	3558000013*	Hold Down Weld	1
2	4017001271	Angle	2
3	7105181650	Capscrew, 0.50"-20NF x 2.00"	8
4	7950180153	Flatwasher, 0.50" ID	12
5	7660182333	Locknut, 0.50"-20NF	4
6	7274000046	Retaining Clamp	2
7	7105202250	Capscrew, 0.63"-18NF x 2.25"	4
8	7660202347	Locknut, 0.63"-18NF	4
9	7701000063	Plug	4
10	4679000153*	Wear Pad	2
11	7118161026*	Flathead Screw, 0.38"-16NC x 1.25"	6
12	7660162601*	Locknut, 0.38-16NC	6
13	4679000221*	Wear Pad	2
14	4812000071*	Shim - 0.12"	2
15	4812000072*	Shim - 0.06"	2
16	7114151218*	Capscrew, 0.31"-18NC x 1.50"	4
17	7660152601*	Locknut, 0.31"-18NC	4
18	7660182333	Locknut, 0.50"-20NF	4

\* also available in Hold Down Assembly, P/N 3558000014

# HOLD DOWN (OUTBOARD TILT CYLINDERS)

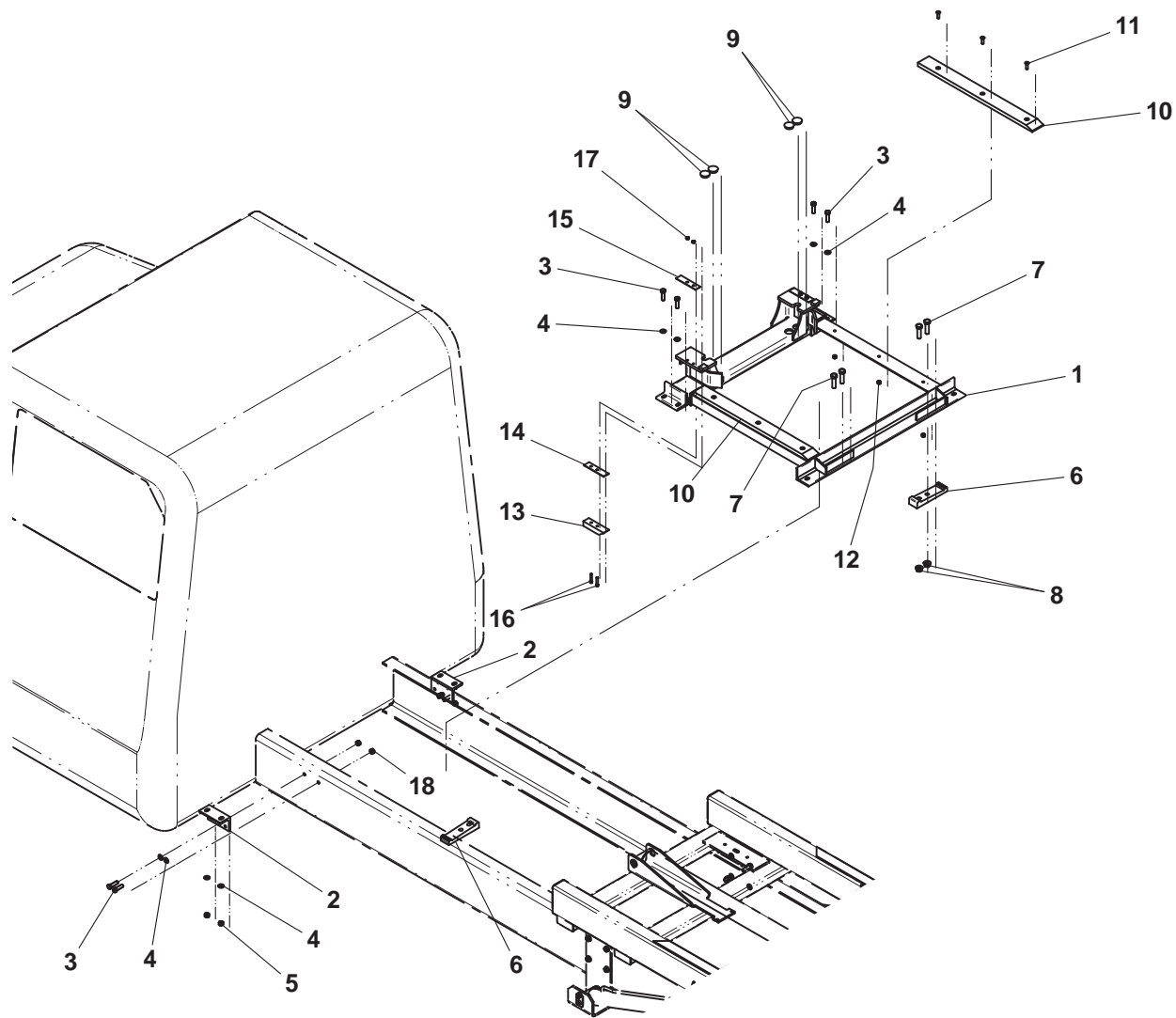

**HOLD DOWN (INBOARD TILT CYLINDERS)**

ITEM	PART NO.	DESCRIPTION	QTY
1	3558000013*	Hold Down Weld	1
2	4017001250	Angle	2
3	7105181650	Capscrew, 0.50"-20NF x 2.00"	2
4	7660182333	Locknut, 0.50"-20NF	2
5	7274000046	Retaining Clamp	2
6	7105202250	Capscrew, 0.63"-18NF x 2.75"	4
7	7660202347	Locknut, 0.63"-18NF	4
8	7701000063	Plug	4
9	4679000153*	Wear Pad	2
10	7118161026*	Flathead Screw, 0.38"-16NC x 1.25"	6
11	7660162601*	Locknut, 0.38"-16NC	6
12	4679000221*	Wear Pad	2
13	4812000071*	Shim - 0.12"	2
14	4812000072*	Shim - 0.06"	2
15	7114151218*	Capscrew, 0.31"-18NC x 1.50"	4
16	7660152601*	Locknut, 0.31"-18NC	4
17	4062000281	Bar (UD 1800/2000/2300)	4

\* also available in Hold Down Assembly, P/N 3558000014

# HOLD DOWN (INBOARD TILT CYLINDERS)

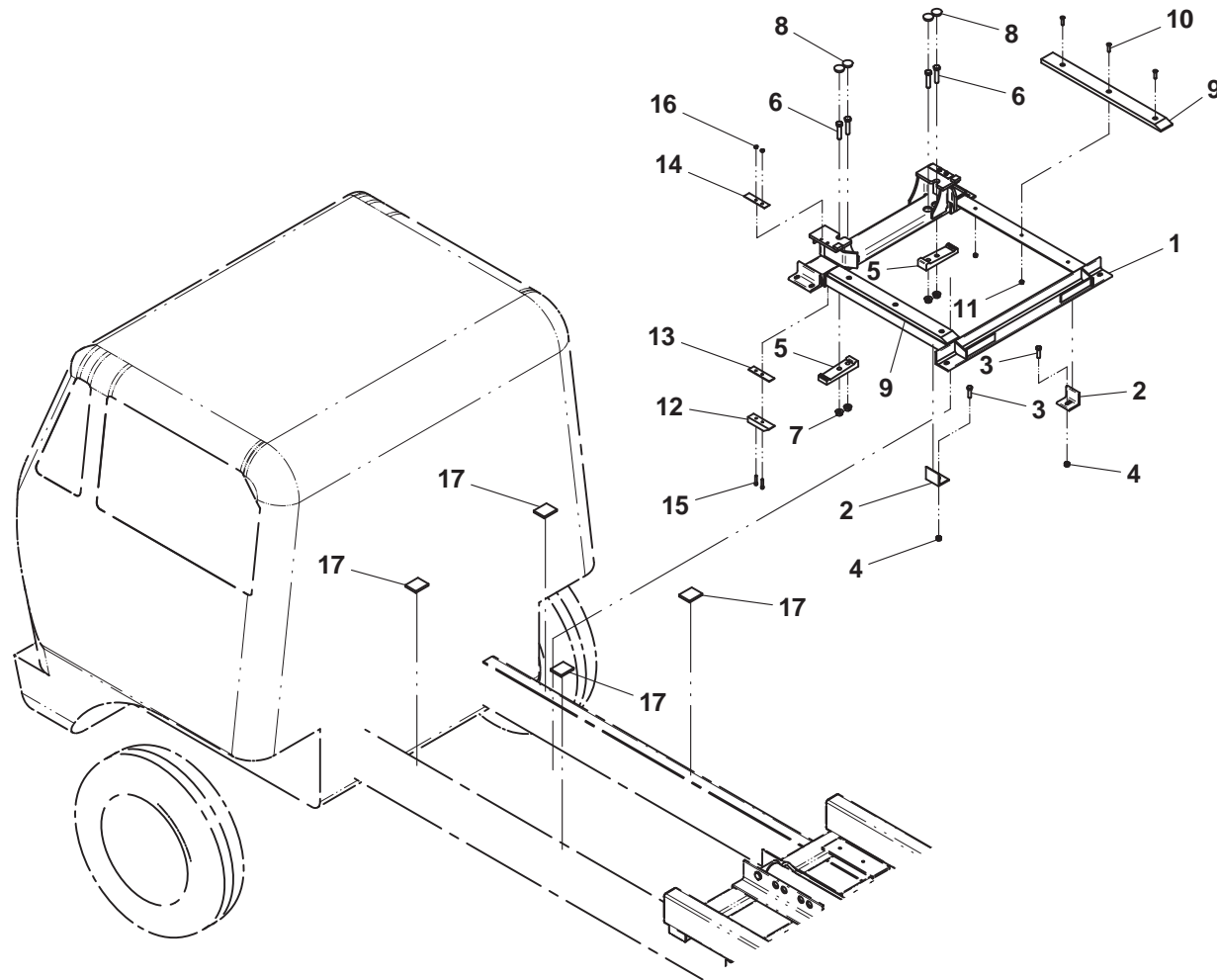

**SLIDE PAD**

ITEM	PART NO.	DESCRIPTION	QTY
1	4679000145*^	Wear Pad	12
2	4679000154^	Wear Pad (20' & 21' decks only)	2
3	7118161026*	Screw, 0.38"-16NC x 1.25" (19' decks)	36
	7118161026^	Screw, 0.38"-16NC x 1.25" (20' & 21' decks)	40
4	7660162601*	Locknut, 0.38"-16NC (19' decks)	36
	7660162601^	Locknut, 0.38"-16NC (20' & 21' decks)	40

\* included in Wear Pad Kit P/N 9577000226 for 19' decks

^ included in Wear Pad Kit P/N 9577000227 for 20' & 21" decks

# SLIDE PAD

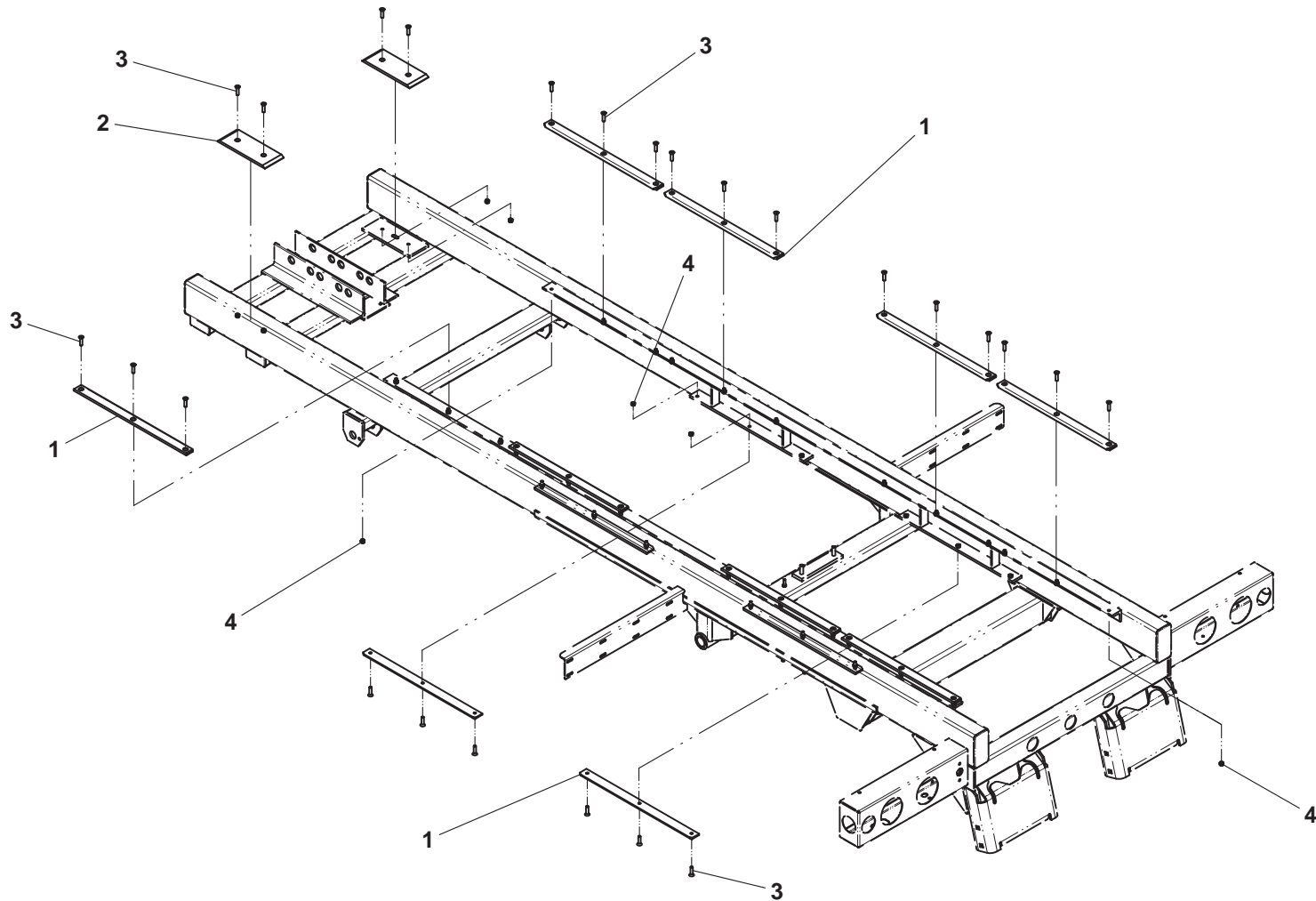

**MUD FLAP**

ITEM	PART NO.	DESCRIPTION	QTY
1	7638000004	Mud Flap - Standard, 30" long	2
	7638000013	Mud Flap - High Frame, 36" long	
2	4706000233	Plate - Standard	2
	4706004383	Plate - Galvanized	
3	7111150864	Carriage Bolt, 0.31"-18NC x 1.00"	8
4	7660152601	Locknut, 0.31"-18NC	8



# MUD FLAP

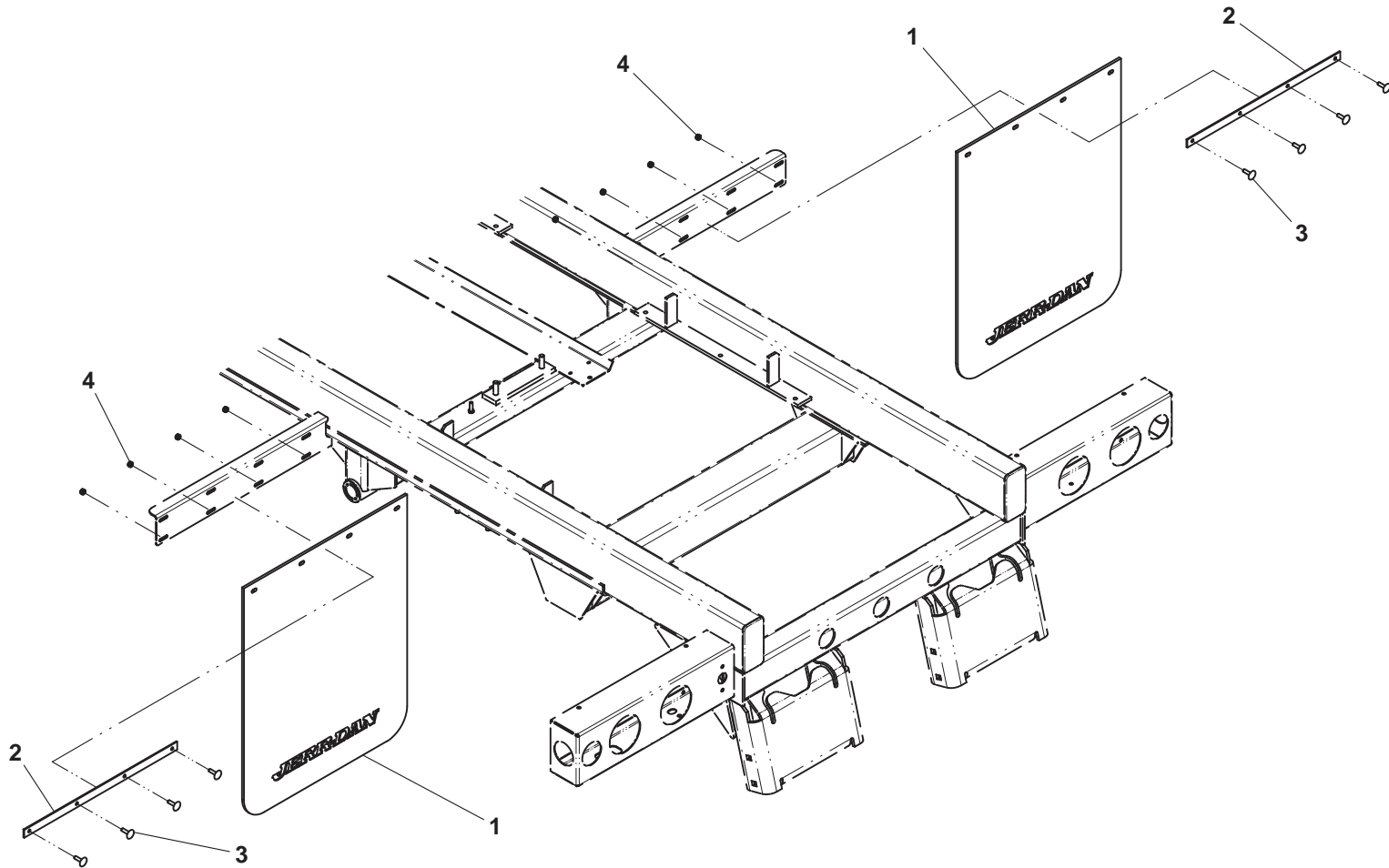

**MUD FLAP - FORD F550 & DODGE RAM 5500**

ITEM	PART NO.	DESCRIPTION	QTY
1	7638000004*	Mud Flap - Standard, 30" long	2
	7638000013*	Mud Flap - High Frame, 36" long	
2	4017001550*	Mount Angle	1
3	4706000233*	Plate	2
4	7178000044*	Anti-Sail Bracket	2
5	4017001587*	Angle	2
6	7115151050*	Capscrew, 0.31"-18NC x 1.25" (Ford)	4
	7115151250*	Capscrew, 0.31"-18NC x 1.50" (Dodge)	
7	7950150161*	Flatwasher, 0.31" ID	12
8	7660152601*	Locknut, 0.31"-18NC	12
9	7111151264*	Carriage Bolt, 0.31"-18NC x 1.50"	4
10	7111150864*	Carriage Bolt, 0.31"-18NC x 1.00"	4

\* 2008 and later F550 with diesel engine

# MUD FLAP - FORD F550 & DODGE RAM 5500

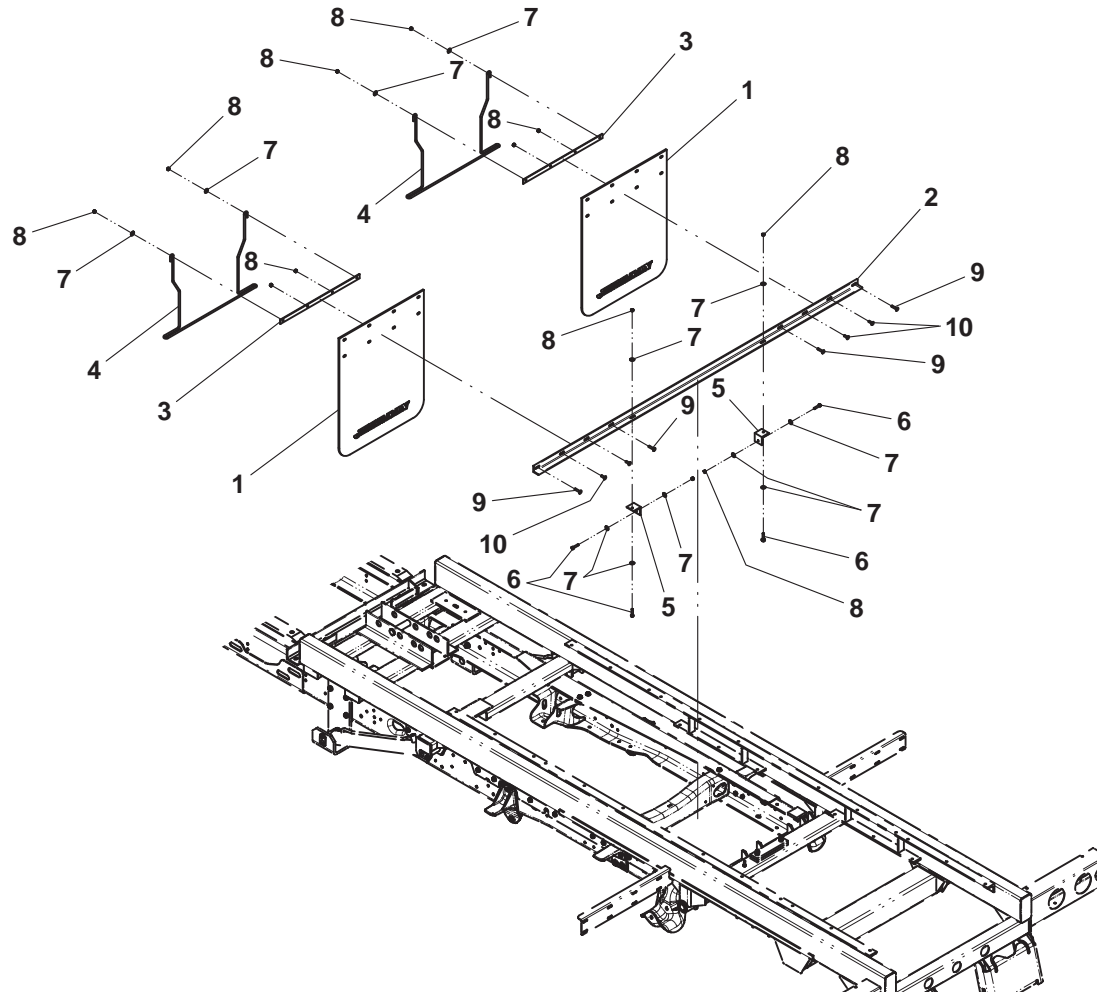

Dodge Ram 5500 frame shown

**FINAL ASSEMBLY**

ITEM	PART NO.	DESCRIPTION	QTY
1	3190000037	Bumper Tube Weld - Short - Standard	2
	3190000050	Bumper Tube Weld - Short - Galvanized	
	3190000034	Bumper Tube Weld - Long - Standard	
	3190000049	Bumper Tube Weld - Long - Galvanized	
2	7115181064	Carriage Bolt, 0.50"-13NC x 1.25"	8
3	7660182601	Locknut, 0.50"-13NC	8
4	4314000043	Light Box Cover - Standard	2
	4314000072	Light Box Cover - Galvanized	
5	7661000042	U-Nut, 0.25"-20NC	8
6	7949000023	Nylon Washer, 0.26" ID	18
7	7114140529	Screw, 0.25"-20NC x 0.63"	8
8	7493000002	Grommet	4
9	7590000113	Back-Up Light - White (Std)	2
10	7590000341	Stop/Tail/Turn Light - Red (LED)	2
11	7493000009	Grommet	4
12	7590000343	Marker Light - Red (LED)	4
13	7493000023	Grommet	3
14	7590000340	Marker Light - Red (LED)	3
15	7493000010	Grommet	1
16	7590000251	License Plate Light	1
17	7011000007	Back-Up Alarm	1
18	7114140528	Screw, 0.25"-20NC x 0.63"	2
19	7660142601	Locknut, 0.25-20NC	2
20	7701000049	Plug	1
21	7701000055	Plug	2
22	Not Required		
23	7330000428	Reflective Tape	2
24	4314000200	Cover Plate - Standard	2
	4314000204	Cover Plate - Galvanized	
25	7679000020	Non-Skid Pad	2
26	7115140850	Screw, 0.25"-20NC x 1.00"	8
27	7950140000	Lockwasher, 0.25" ID	8
28	7661000064	U-Nut Clip, 0.25"-20NC	8
29	4178000863	Bracket	1

# FINAL ASSEMBLY

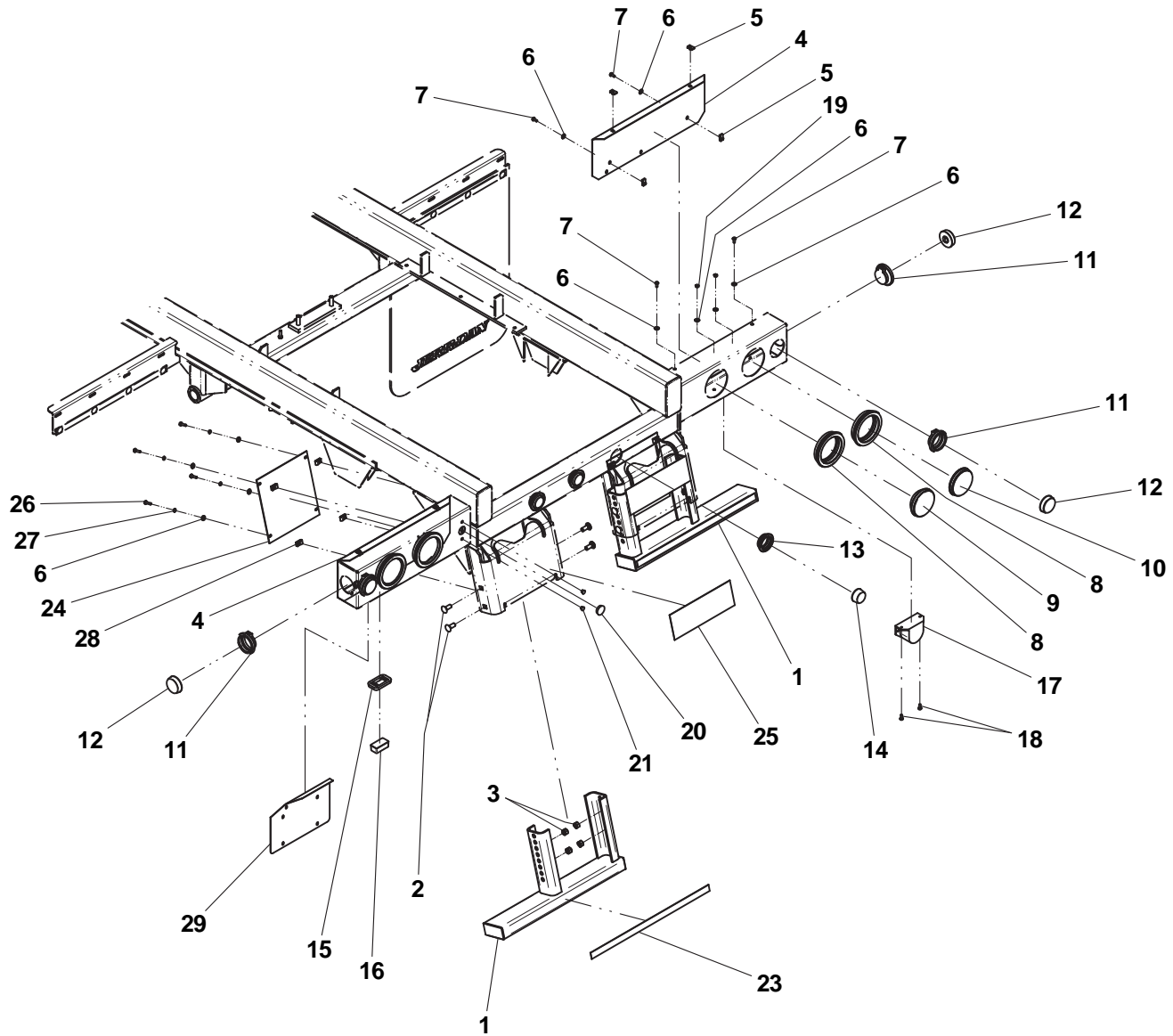

**FINAL ASSEMBLY - GALVANIZED SUBFRAME**

ITEM	PART NO.	DESCRIPTION	QTY
1	4017001566	Angle - LH	1
2	4017001567	Angle - RH	1
3	7114150818	Capscrew, 0.31"-18NC x 1.00	14
4	7950150153	Flatwasher, 0.31" ID	14
5	7660152601	Locknut, 0.31"-18NC	14
6	3178000544	Lightbox - LH	1
7	3178000545	Lightbox - RH	1

# FINAL ASSEMBLY - GALVANIZED SUBFRAME

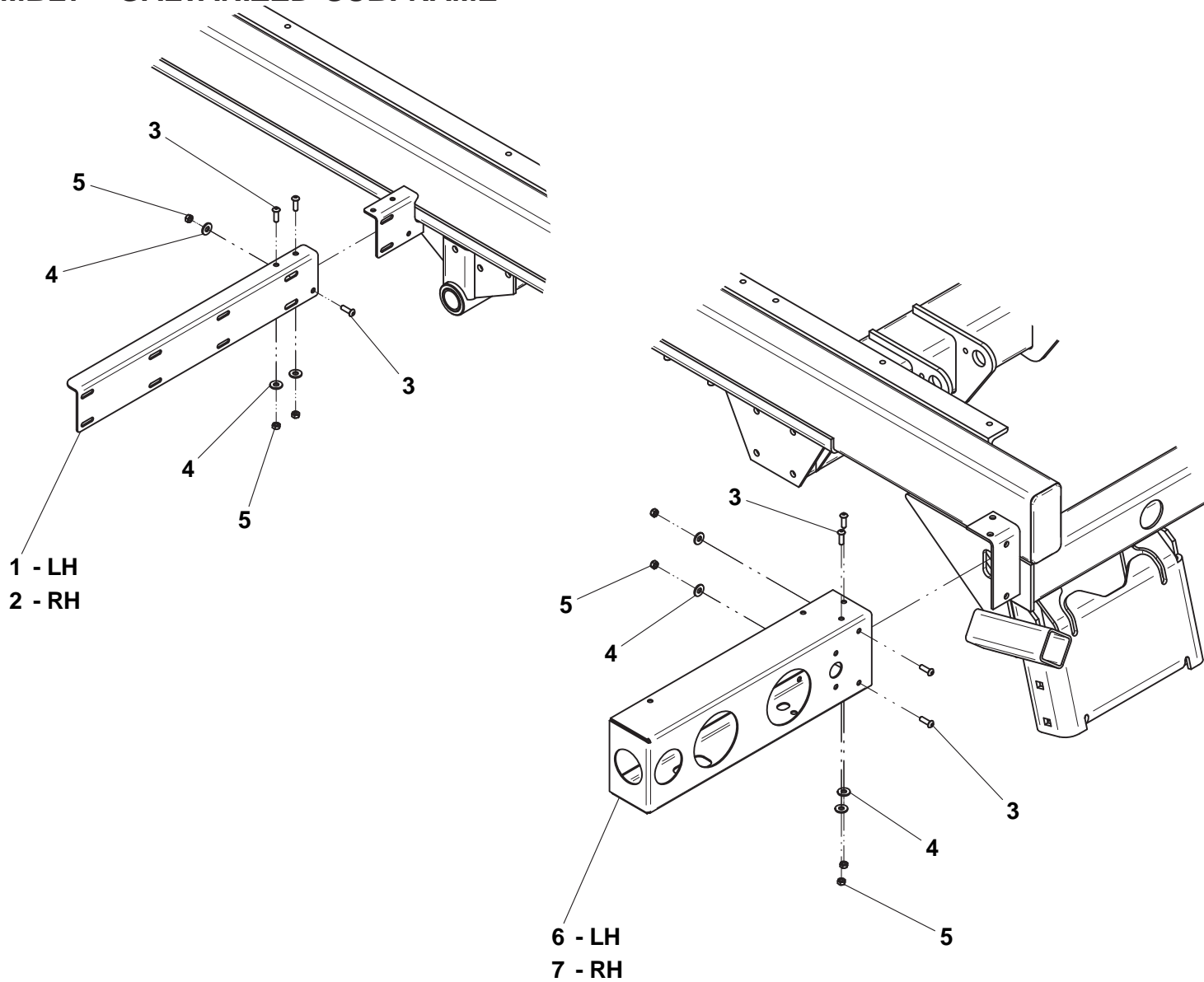

**FORD F550 FRAME REINFORCEMENT AND SPRING SPACERS**

ITEM	PART NO.	DESCRIPTION	QTY
1	3177000053	Brace Weld - LH	1
2	3177000054	Brace Weld - RH	1
3	7105201250	Capscrew, 0.63"-18NF x 1.75"	2
4	7660202347	Locknut, 0.63"-18NF	2
5	7105171450	Capscrew, 0.44"-20NF x 1.75"	18
6	7105171050	Capscrew, 0.44"-20NF x 1.25"	19
7	7660172331	Locknut, 0.44"-20NF	37
8	7950170142	Flatwasher, 0.44" ID	21
9	7274000076	Clamp	1
10	7115151050	Capscrew, 0.31"-18NC x 1.25"	1
11	7950150161	Flatwasher, 0.31" ID	1
12	7660152601	Locknut, 0.31"-18NC	2
13	7785152420	Set Screw, 0.31"-18NC x 1.50"	1
14	7661000065	Nut, M10 x 1.5	2
15	7813000048	Spacer	2
16	7120000044	U-Bolt	4



# FORD F550 FRAME REINFORCEMENT AND SPRING SPACERS

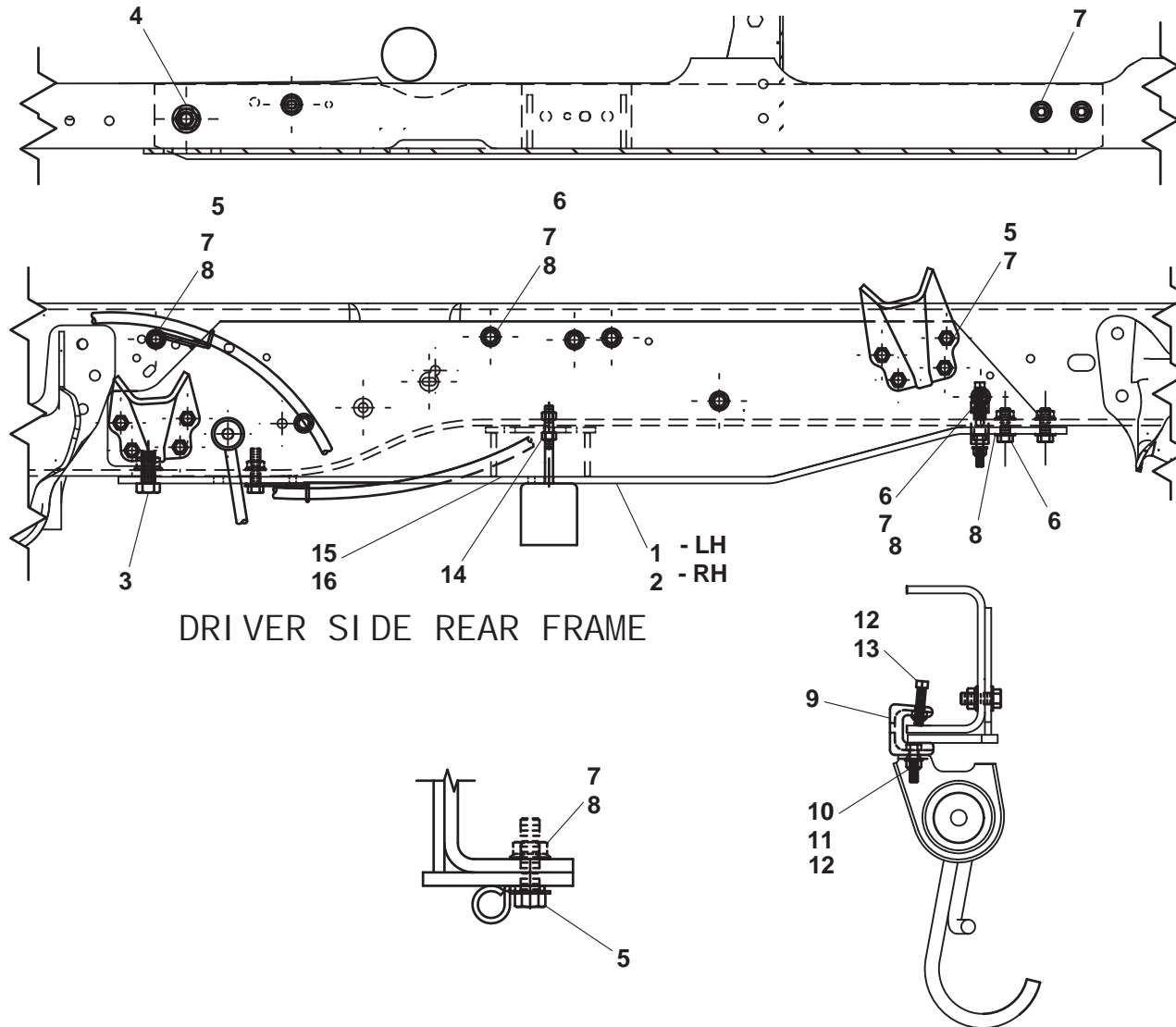

**FORD F550 SUBFRAME MODIFICATIONS**

ITEM	PART NO.	DESCRIPTION	QTY
1	4062000281	Bar	2
2	4178000283	Bracket	1
3	7570000016	Fuel Filler Hose	1
4	7570000017	Fuel Vent Hose	1
5	7790161253	Screw, 0.38"-16NC x 0.75"	2
6	7277000001	Clevis	1
7	4809000003	Sheave	1
8	7690151601	Clevis Pin	1
9	7690021610	Cotter Pin	1
10	7105150850	Capscrew, 0.31"-24NF x 1.00"	1
11	7950150161	Flatwasher, 0.31" ID	3
12	4178000287	Bracket	1
13	7115151050	Capscrew, 0.31"-18NC x 1.25"	2
14	7660152601	Locknut, 0.31"-18NC	2

# FORD F550 SUBFRAME MODIFICATIONS

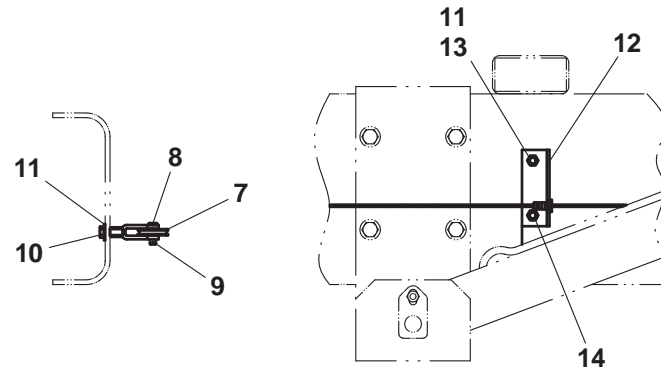

DRIVER'S SIDE

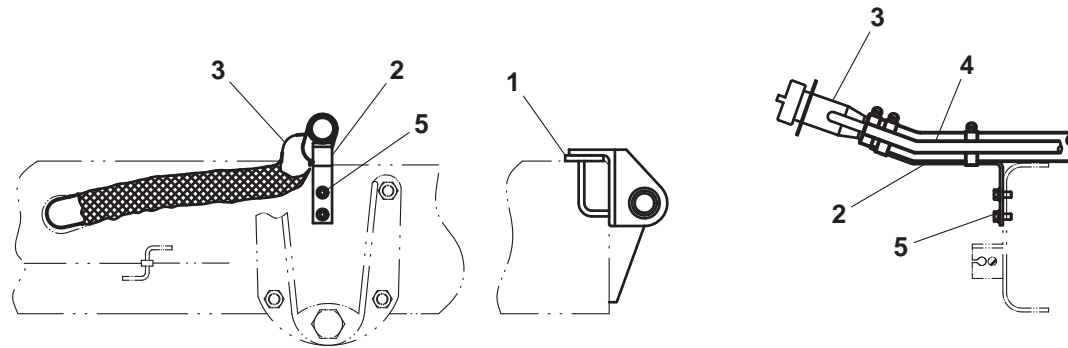

DRIVER'S SIDE

**GM C4500/5500 SUBFRAME MODIFICATIONS**

ITEM	PART NO.	DESCRIPTION	QTY
1	4178000421	Bracket	1
2	7570000023	Fuel Filler Hose (2005 & earlier)	1
	7570000031	Fuel Filler Hose (2006 & later)	
3	7912000233	Fuel Fillneck (2006 & later diesel)	1
	7912000235	Fuel Fillneck (2006 & later gas)	
4	7570000017	Fuel Vent Hose (2006 & later diesel)	1
5	7254000021	Fill Cap (2006 & later gas only)	1
6	7790151253	Taptite Screw, 0.31"-18NC x 0.75"	2

# GM C4500/5500 SUBFRAME MODIFICATIONS

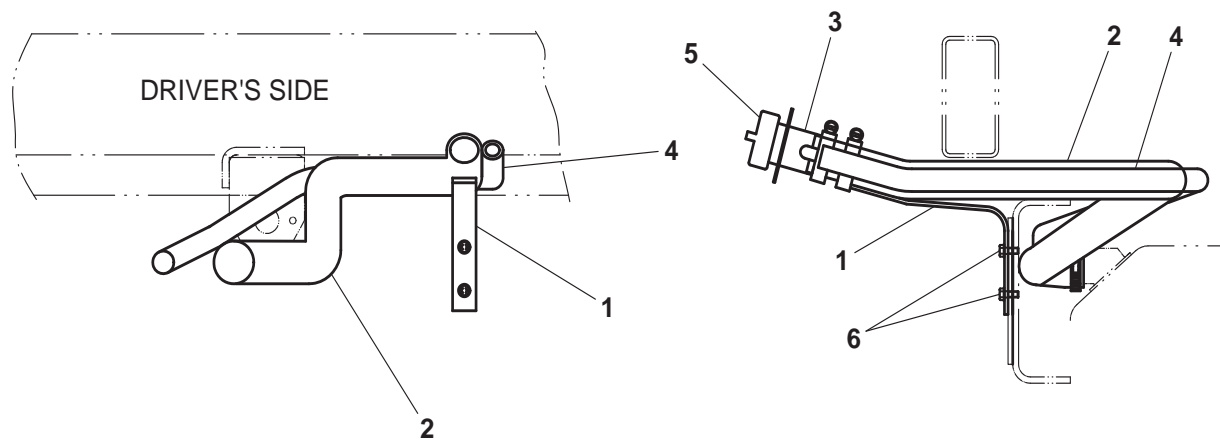

**GM C4500/5500 BRAKE CABLE REWORK AND REAR FUEL TANK MODIFICATIONS**

ITEM	PART NO.	DESCRIPTION	QTY
1	4178000421	Bracket	1
2	7570000025	Fuel Filler Hose (2005 & earlier)	1
3	7912000234	Fuel Fillneck (2006 & later diesel)	1
	7912000236	Fuel Fillneck (2006 & later gas)	
4	7105181650	Capscrew, 0.50"-20NF x 2.00"	2
5	7950180153	Flatwasher, 0.50" ID	2
6	7660182333	Locknut, 0.50"-20NF	2
7	4178000474	Bracket	1
8	4178000475	Bracket (2006 & earlier)	1
	4178000682	Bracket (2007 & later)	

# GM C4500/5500 BRAKE CABLE REWORK AND REAR FUEL TANK

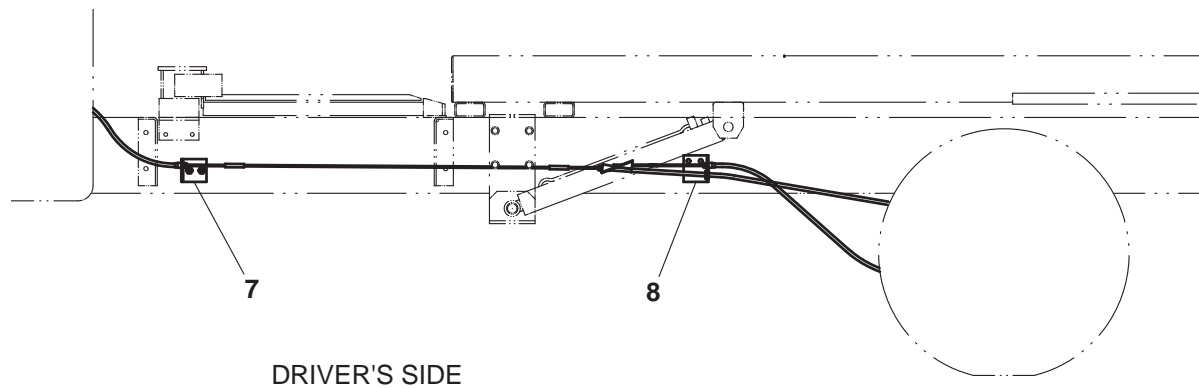
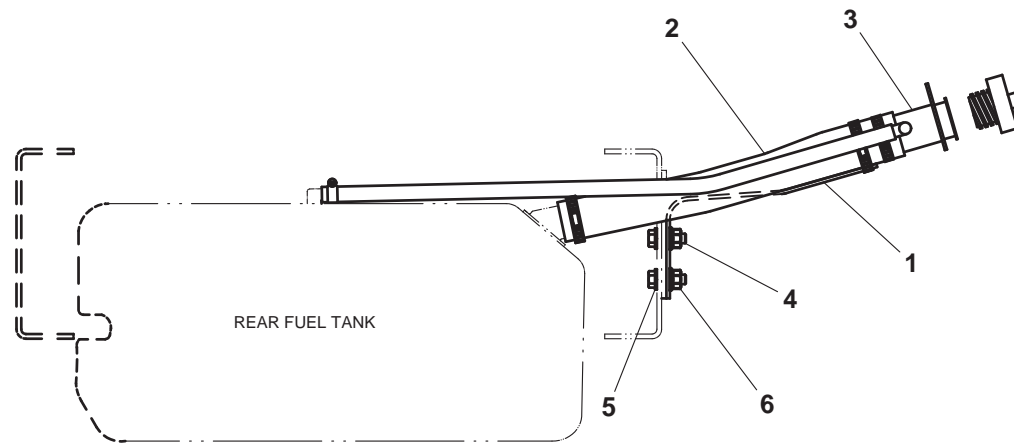

**DODGE RAM 5500 FRAME REINFORCEMENT**

ITEM	PART NO.	DESCRIPTION	QTY
1	7577000483	Frame Reinforcement Kit	1



# DODGE RAM 5500 FRAME REINFORCEMENT

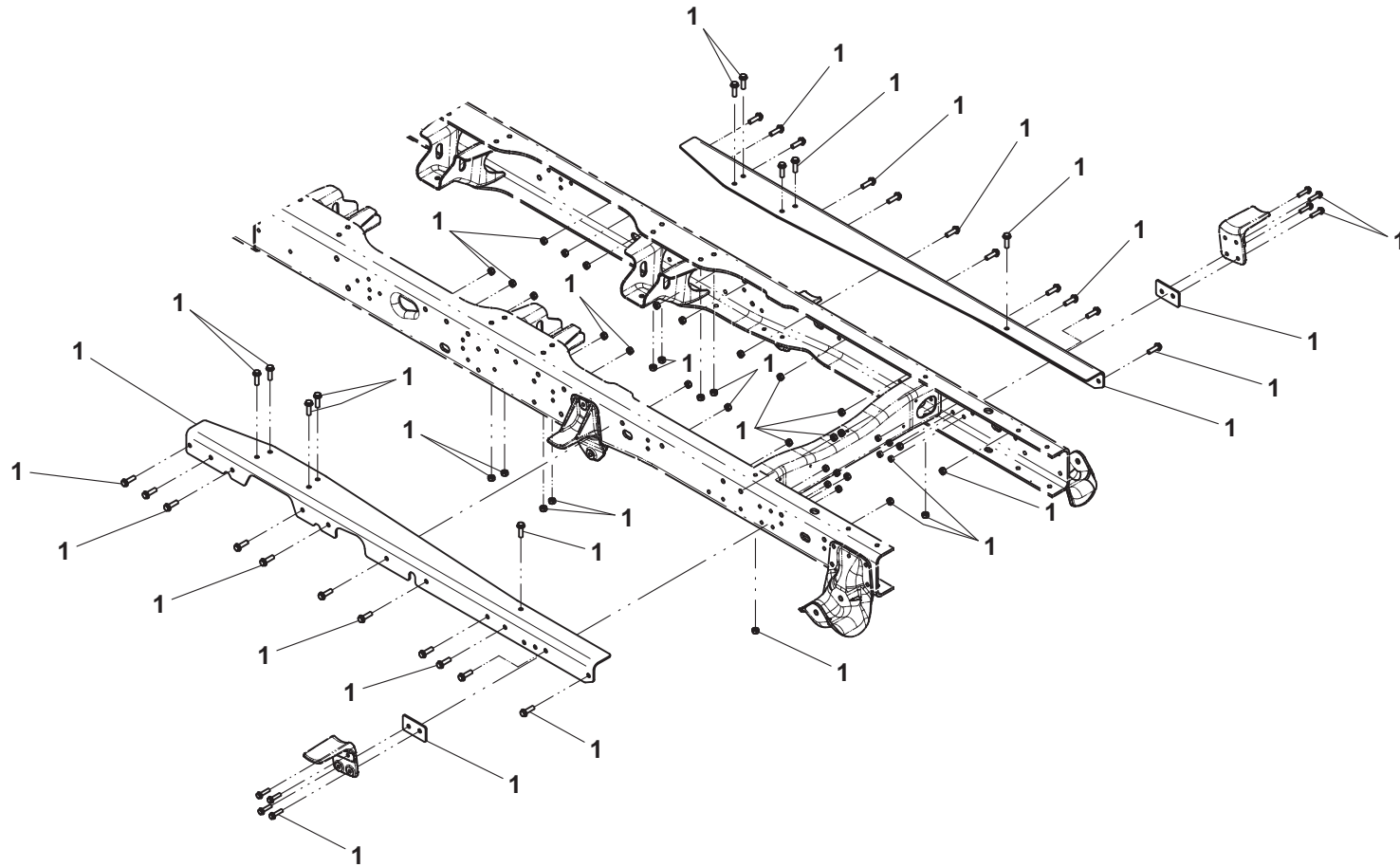

**DODGE RAM 5500 BRAKE CABLE REWORK**

ITEM	PART NO.	DESCRIPTION	QTY
1	4277000005	Adjustable Clevis	1
2	4809000003	Sheave	1
3	7690151601	Clevis Pin	1
4	7690021610	Cotter Pin	1
5	7105150850	Capscrew, 0.31"-24NF x 1.00"	1
6	7950150161	Flatwasher, 0.31" ID	2
7	4178000747	Bracket	1
8	7115181005	Capscrew, 0.50"-13NC x 1.25"	1
9	7660182601	Locknut, 0.50"-13NC	1

# DODGE RAM 5500 BRAKE CABLE REWORK

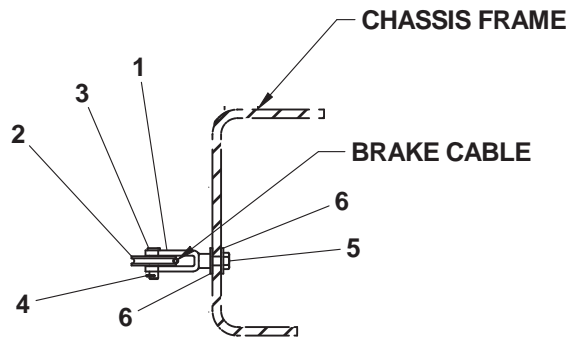
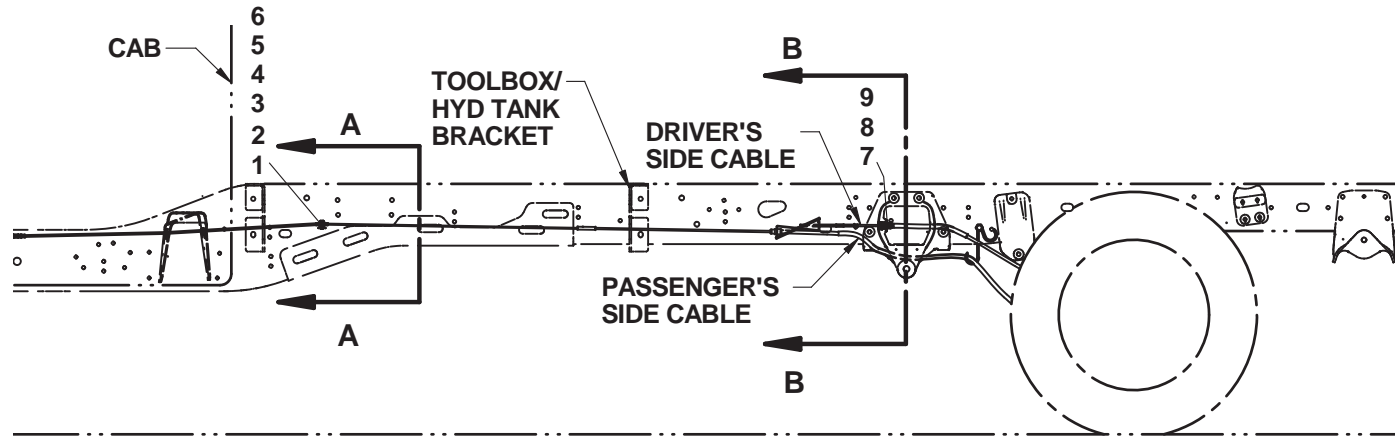

SECTION A-A

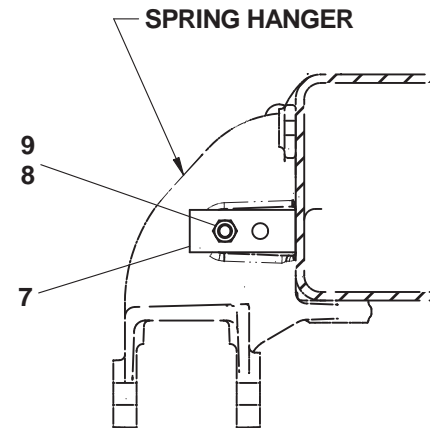

SECTION B-B

**DODGE RAM 5500 FUEL TANK HOSE INSTALL**

ITEM	PART NO.	DESCRIPTION	QTY
1	4178000421	Bracket	1
2	7570000016	Fuel Filler Hose (OEM fuel tank)	1
	7570000035	Fuel Filler Hose (TFI fuel tank)	
3	7570000017	Fuel Vent Hose	1
4	7890000041	Tank (Dodge 48 gal)	1

# DODGE RAM 5500 FUEL TANK HOSE INSTALL

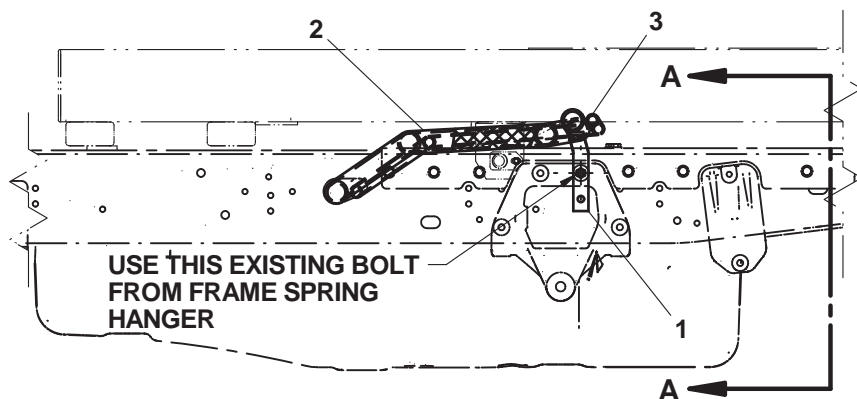

OEM FUEL TANK

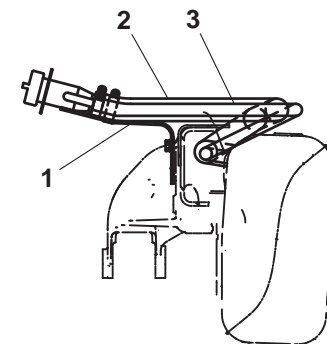

SECTION A-A

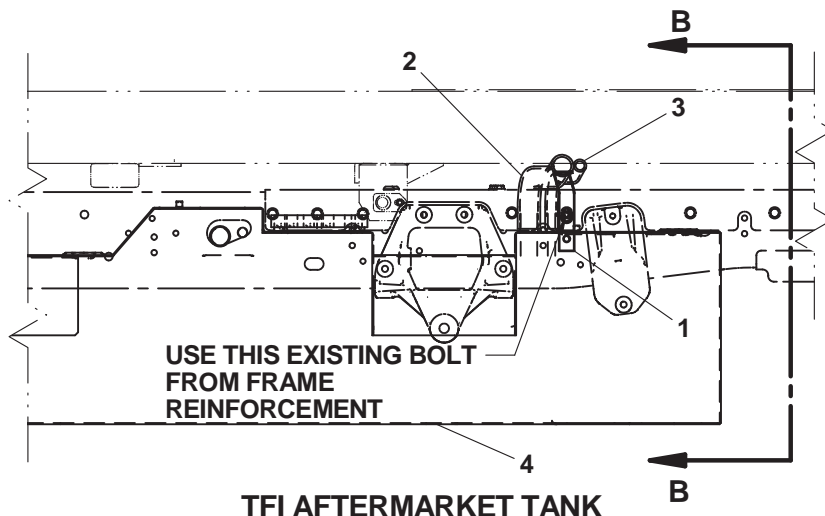

TFI AFTERMARKET TANK

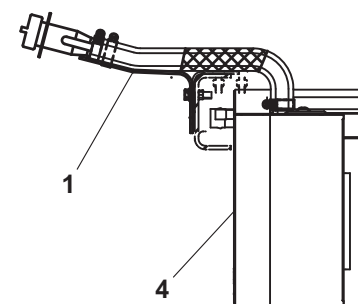

SECTION B-B

**ISUZU NRR FRAME REINFORCEMENT - 21' DECK**

ITEM	PART NO.	DESCRIPTION	QTY
1	4177000064	Brace - LH	1
2	4177000063	Brace - RH	1
3	7105171450	Capscrew, 0.44"-20NF x 1.75"	2
4	7105171050	Capscrew, 0.44"-20NF x 1.25	38
5	7950170142	Flatwasher, 0.44" ID	42
6	7660172331	Locknut, 0.44"-20NF	40
7	4062000692	Bar	6

# ISUZU NRR FRAME REINFORCEMENT - 21' DECK

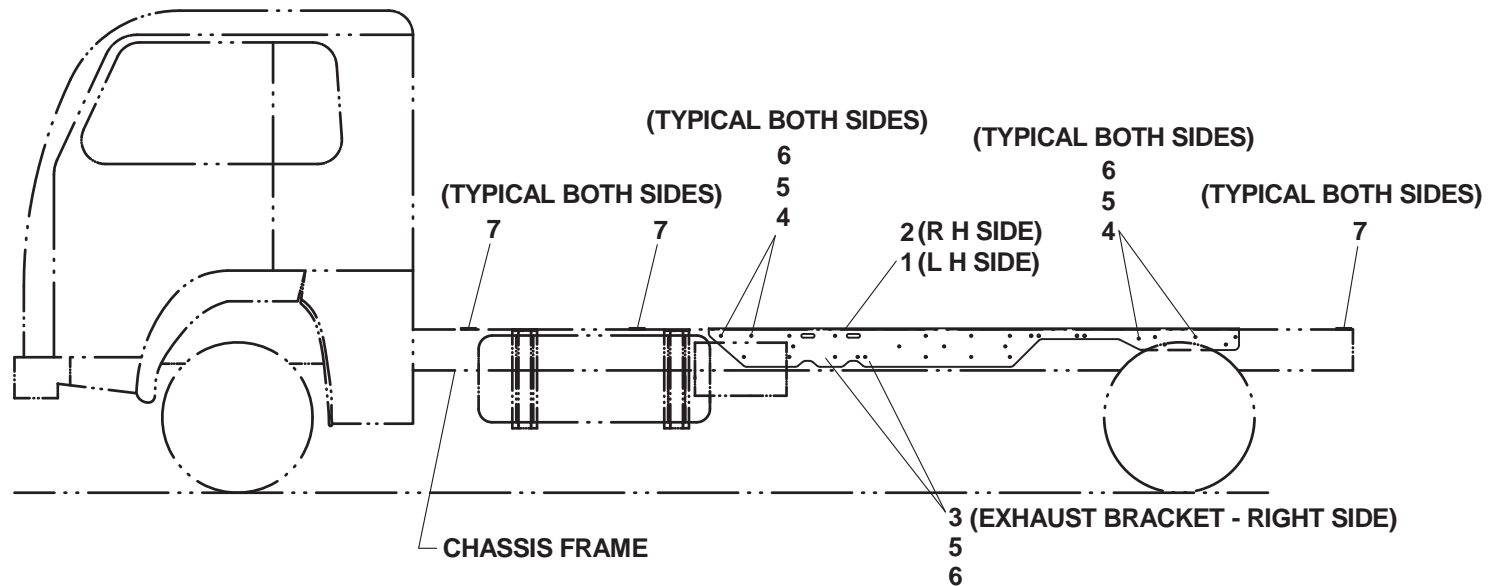

**HYDRAULIC RESERVOIR AND TOOLBOX / BASKET**

ITEM	PART NO.	DESCRIPTION	QTY*	ITEM	PART NO.	DESCRIPTION	QTY*
1	4178000331	Mounting Bracket - Short		20	4632000015	Moulding - 15" deep basket	
	4178000291	Mounting Bracket - Std			4632000048	Moulding - 24" deep basket	
	4178000339	Mounting Bracket - Long		21	7002000410	Stainless Steel Cover Plate for Basket includes rivets	
2	4178000330	Mounting Bracket - Short		22	3178000566	Bracket Weldment	
	4178000290	Mounting Bracket - Std		23	7701000051	Plug	
	4178000338	Mounting Bracket - Long					
3	3750000018	Hydraulic Reservoir Assembly					
4	7183000004+	Breather Filler Cap Assembly					
5	7470000009+	Level / Temperature Gauge					
6	7430000014+	Strainer					
7	7105181650	Capscrew, 0.50"-20NF x 2.00"					
8	7950180153	Flat Washer, 0.50" ID					
9	7660182333	Locknut, 0.50"-20NF					
10	7115150850	Capscrew, 0.31"-18NC x 1.00"					
11	7950150161	Flatwasher, 0.31" ID					
12	7660152601	Locknut, 0.31"-18NC					
13	3899000130	Toolbox Assembly - 36" x 18" x 18"					
	3899000131	Toolbox Assembly - 36" x 18" x 14"					
	3899000132	Toolbox Assembly - 48" x 18" x 18"					
	3899000133	Toolbox Assembly - 60" x 18" x 18"					
	3899000172	Toolbox Assembly - 78" x 21" X 20"					
14	4679000256^	Rubber Pad (36" toolbox)					
	4679000257^	Rubber Pad (48" toolbox)					
	4679000258^	Rubber Pad (60" toolbox)					
	4679000322^	Rubber Pad (78" toolbox)					
15	7118181216	Capscrew, 0.50"-13NC x 1.50"					
16	7660182301	Locknut, 0.50"-13NC					
17	4706002361	Plate					
18	4017000777	High Mount Angle					
19	3899000053	Basket - 15" deep					
	3899000075	Basket - 24" deep					

+ also available in Hydraulic Reservoir Assembly, P/N 3750000018

^ included in Toolbox Assembly

\* Quantities vary depending on Hydraulic Tank / Toolbox / Basket mounting configuration.



# HYDRAULIC RESERVOIR AND TOOLBOX / BASKET

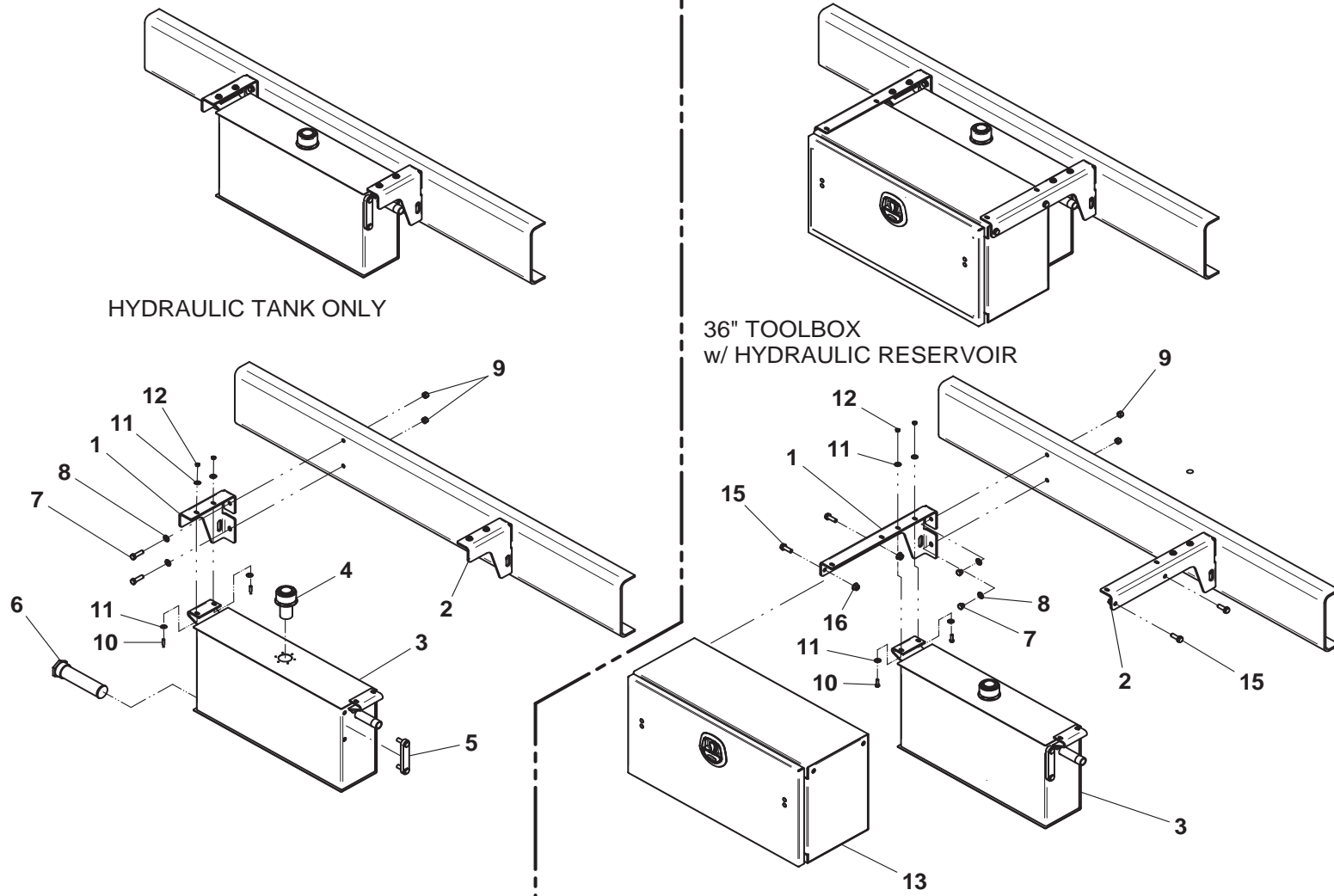

Item #14, Toolbox Rubber Pad, not shown

### HYDRAULIC RESERVOIR AND TOOLBOX / BASKET

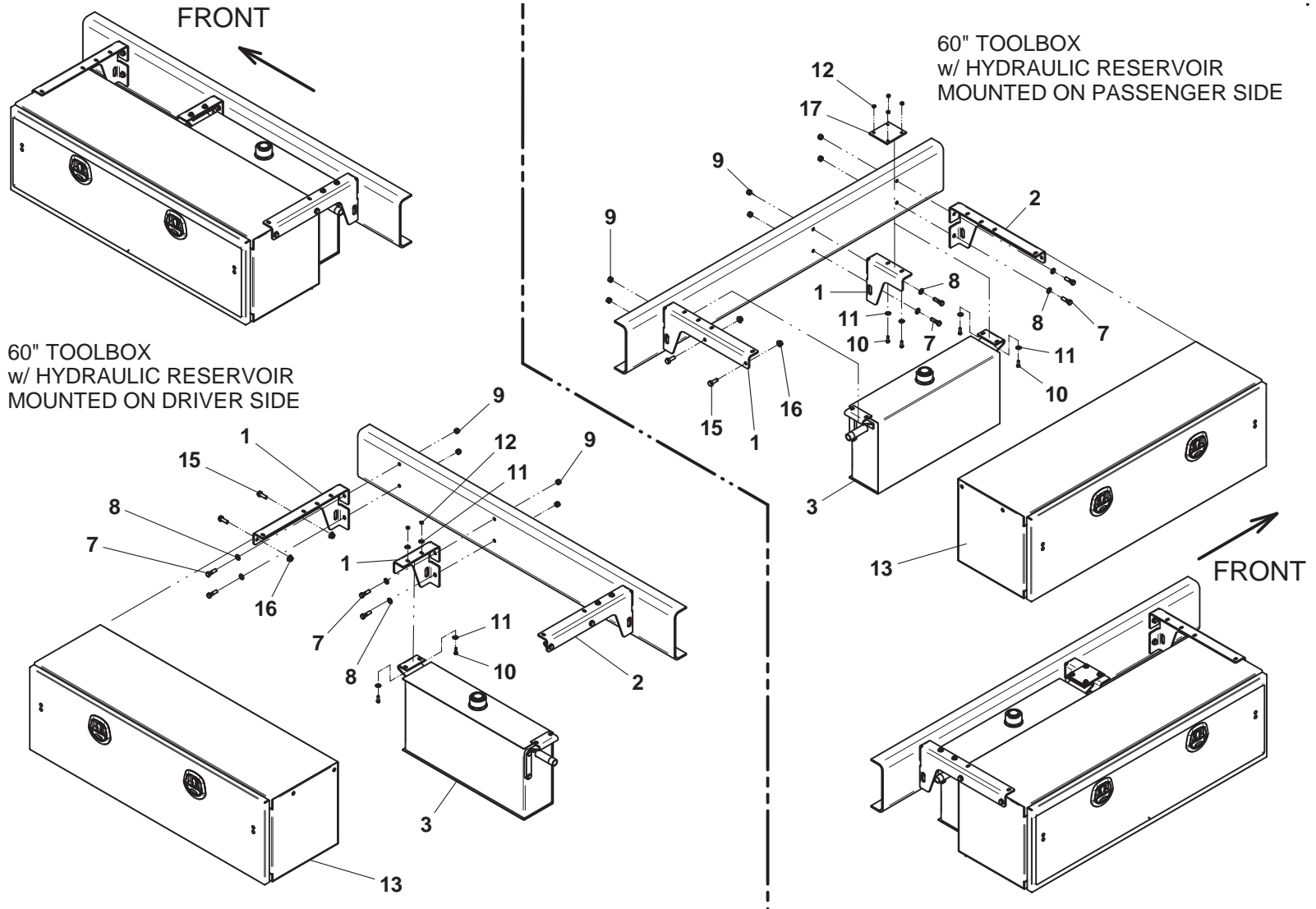

Item #14, Toolbox Rubber Pad, not shown

# HYDRAULIC RESERVOIR AND TOOLBOX / BASKET

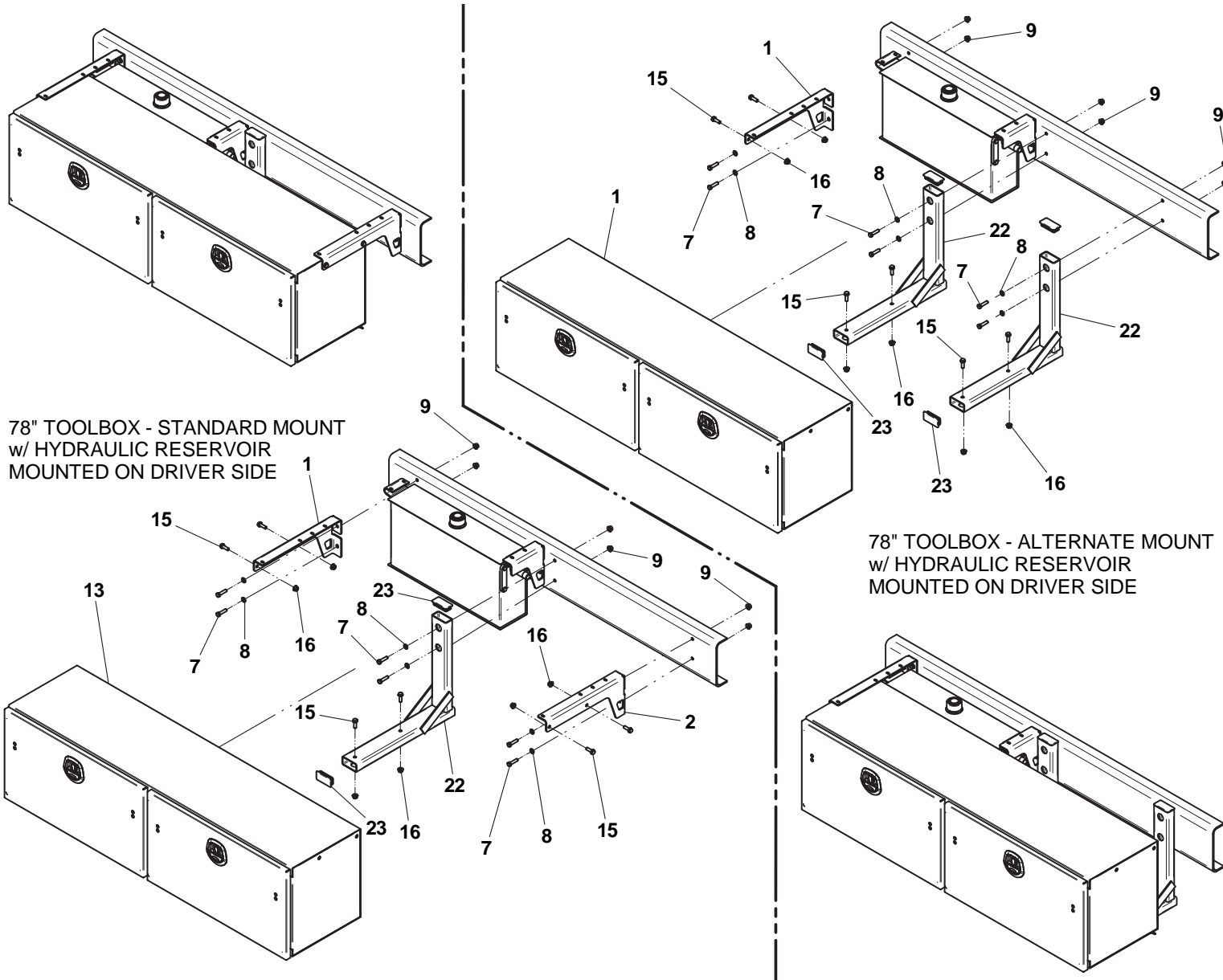

78" TOOLBOX - STANDARD MOUNT  
w/ HYDRAULIC RESERVOIR  
MOUNTED ON DRIVER SIDE

78" TOOLBOX - ALTERNATE MOUNT  
w/ HYDRAULIC RESERVOIR  
MOUNTED ON DRIVER SIDE

### HYDRAULIC RESERVOIR AND TOOLBOX / BASKET

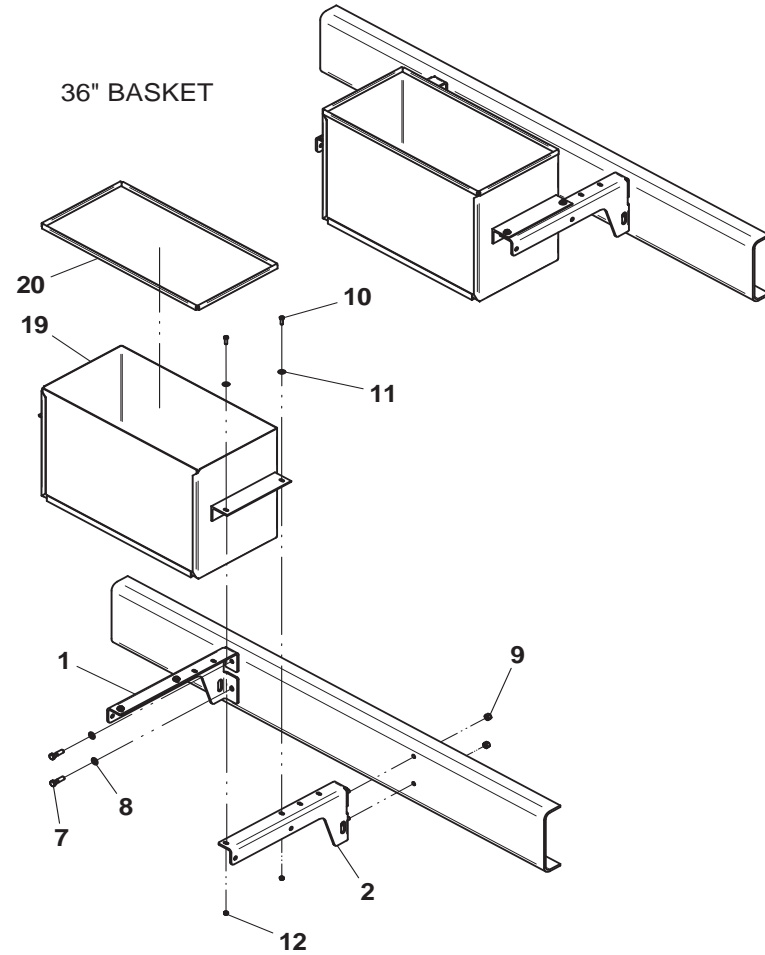
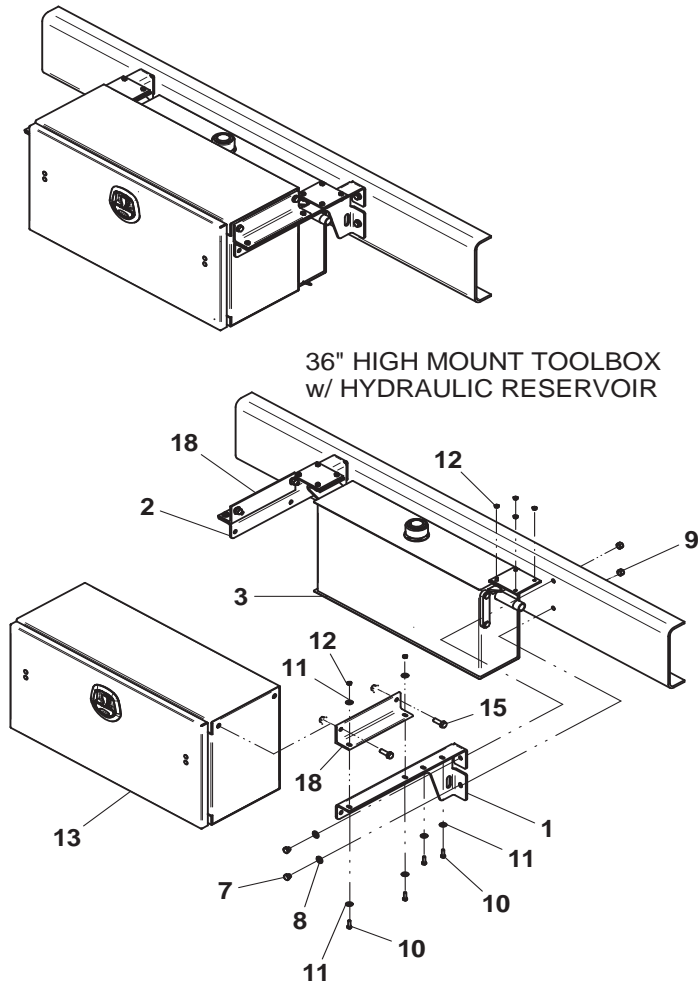

Items #14, Toolbox Rubber Pad and #21, Stainless Cover for Basket, not shown

**THIS PAGE INTENTIONALLY LEFT BLANK**

**TOOLBOX**

ITEM	PART NO.	DESCRIPTION	QTY*
1	4679000256	Rubber Pad (36" toolbox)	1
	4679000257	Rubber Pad (36" narrow toolbox)	1
	4679000258	Rubber Pad (48" toolbox)	1
	4679000259	Rubber Pad (60" toolbox)	1
	4679000322	Rubber Pad (78" toolbox)	1
2	4796000009	Gasket (36" toolbox)	1
	4796000010	Gasket (48" toolbox)	1
	4796000011	Gasket (60" toolbox)	1
	4796000012	Gasket (78" toolbox)	2
3	9899000014	Toolbox Door Assembly (36" toolbox)	1
	9899000015	Toolbox Door Assembly (48" toolbox)	1
	9899000016	Toolbox Door Assembly (60" toolbox)	1
	9899000023	Toolbox Door Assembly (78" toolbox)	1
4	7585000019^	Latch (36", 48", 60" toolbox)	1
	7585000019^	Latch (78" toolbox)	2
5	7555000016^	Hinge (36" toolbox)	1
	7555000015^	Hinge (48" toolbox)	2
	7555000016^	Hinge (60", 78" toolbox)	2
6	7759000020^	Rivet (36" toolbox)	9
	7759000020^	Rivet (48" toolbox)	14
	7759000020^	Rivet (60", 78" toolbox)	18
7	4178000599^	Bracket (36", 48", 60" toolbox)	2
	4178000599^	Bracket (78" toolbox)	4
8	7114140465^	Carriage Bolt, 0.25"-20NC x 0.50" (36", 48", 60" toolbox)	4
	7114140465^	Carriage Bolt, 0.25"-20NC x 0.50" (78" toolbox)	
9	7660142604^	Locknut, 0.25"-20NC (36", 48", 60" toolbox)	4
	7660142604^	Locknut, 0.25"-20NC (78" toolbox)	
10	7592000005^	S Link (36", 48", 60" toolbox)	4
	7592000005^	S Link (78" toolbox)	8
11	7248000114^	Cable (36", 48", 60" toolbox)	2
	7248000114^	Cable (78" toolbox)	4

\* Quantities listed are for one toolbox

^ also included in Toolbox Door Assembly

# TOOLBOX

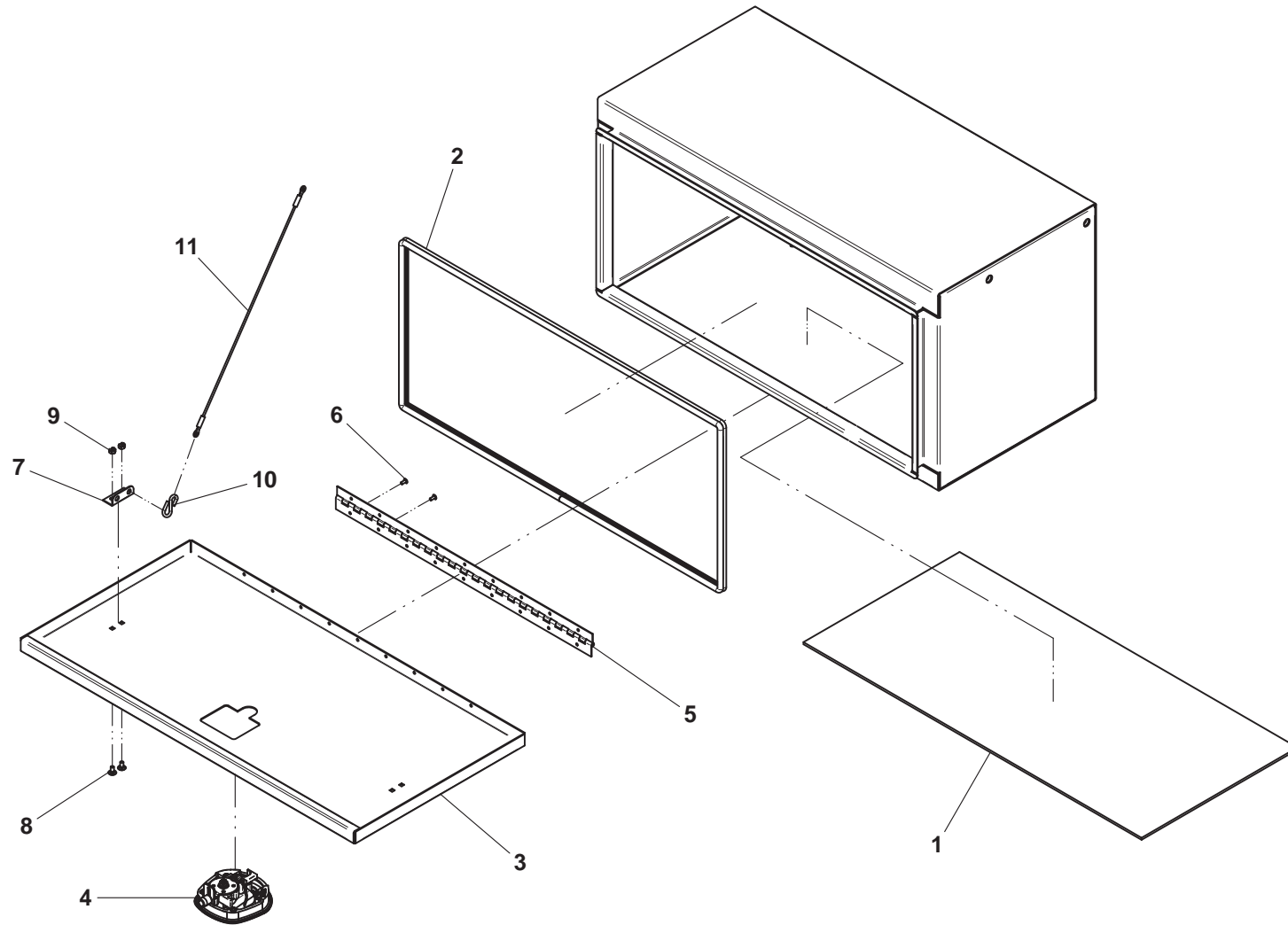

36" Toolbox shown

**TOOLBOX SHELF**

ITEM	PART NO.	DESCRIPTION	QTY
1	4017001403	Angle	2
2	4811000841	Shelf (36" toolbox)	1
	4811000843	Shelf (48" toolbox)	
	4811000868	Shelf (60" toolbox)	
3	7115150850	Capscrew, 0.31"-18NC x 1.00"	4
4	7950150161	Flatwasher, 0.31" ID	8
5	7660152601	Locknut, 0.31"-18NC	4



# TOOLBOX SHELF

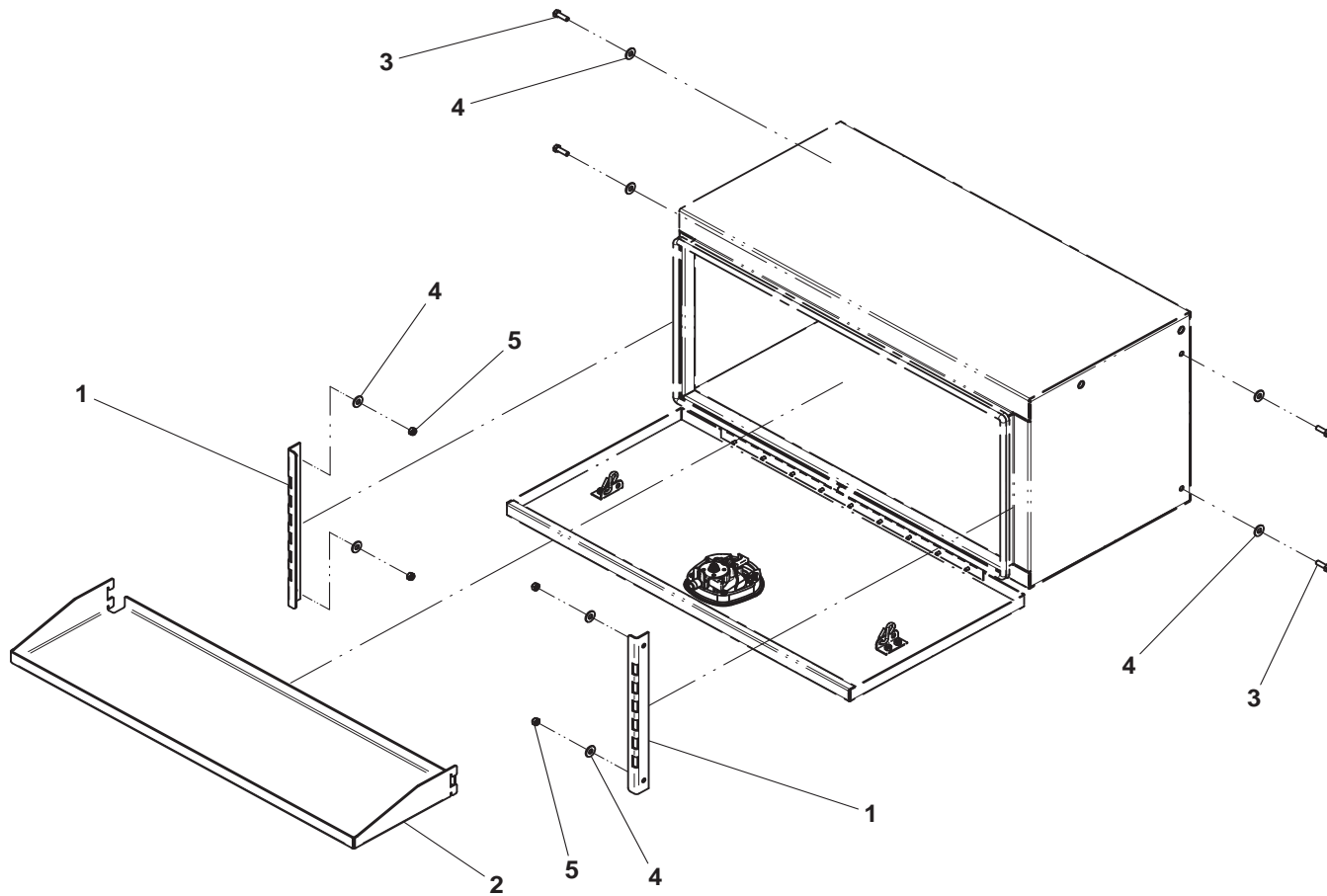

36" Toolbox shown

**TOOLBOX LIGHT**

ITEM	PART NO.	DESCRIPTION	QTY
1	4178000578*	Bracket	1
2	7590000273*	Dome Lamp	1
3	7870000115*	Switch	1
4	7280000007*	Wire Mount Clip	3
5	7661000047*	Panel Nut	4
6	7790100856*	Screw, #10 x 0.50"	4
7	7443000377	Fitting	1
8	7552000297	Toolbox Light Harness	1

\* included in Toolbox Light Bracket Assembly

## TOOLBOX LIGHT

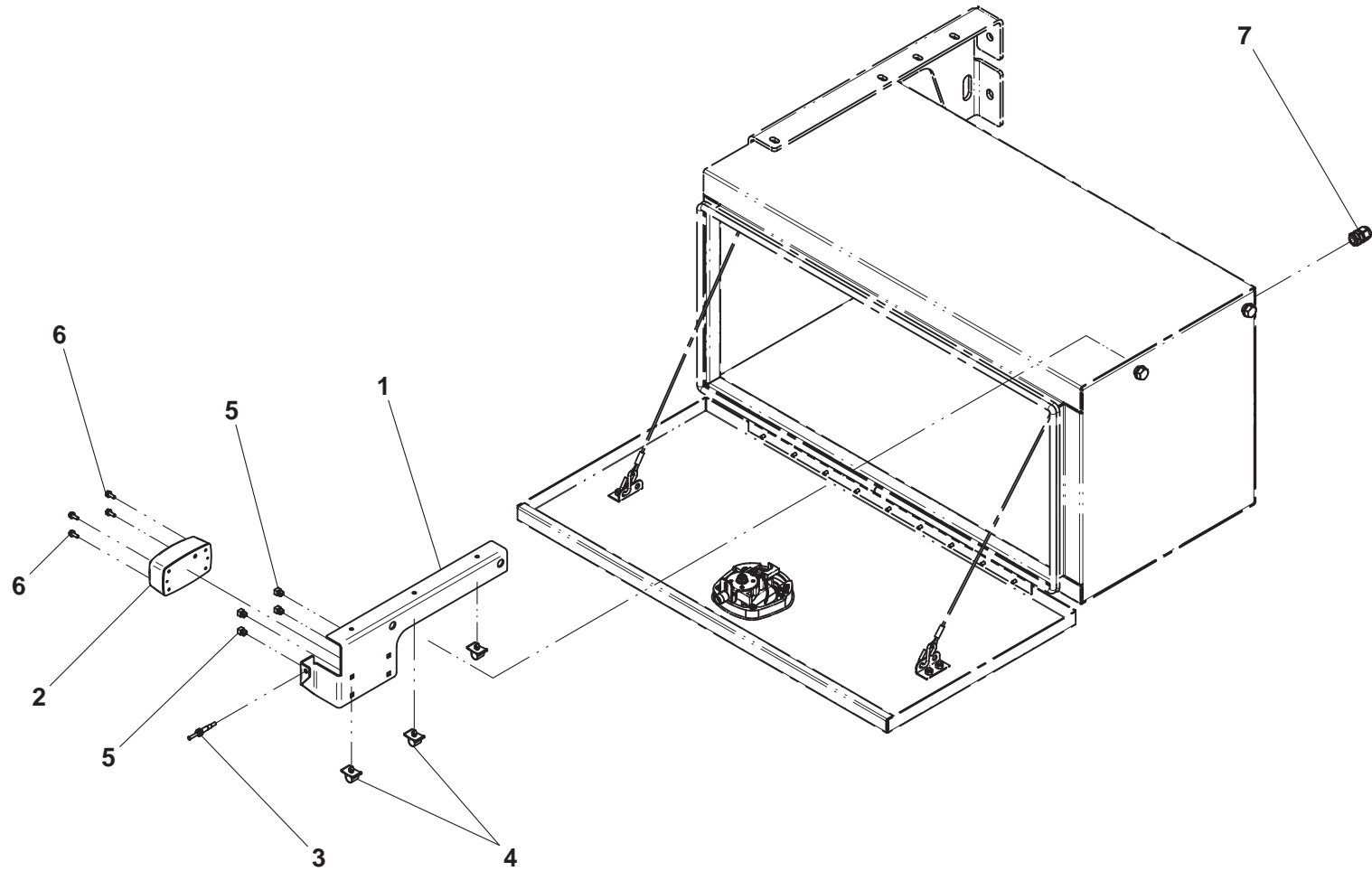

Item #8, Toolbox Light Harness, not shown  
48" Toolbox Shown

**TOOLBOX TOP STOWAGE TRAY AND MARKER LIGHTS**

ITEM	PART NO.	DESCRIPTION	QTY
1	3811000053	Tray Weldment (36" Toolbox)	1
	3811000054	Tray Weldment (48" Toolbox)	
	3811000055	Tray Weldment (60" Toolbox)	
	3811000057	Tray Weldment (78" Toolbox)	
2	4706006216	Plate	2
3	7115160950	Capscrew, 0.38"-16NC x 1.12"	4
4	7950150161	Flat Washer, 0.38" ID	8
5	7660162601	Locknut, 0.38"-16NC	8
6	7493000009	Grommet	2
7	7493000031	Marker Light - Amber (LED)	2
8	7493000031	Grommet	1
9	7552000451	Toolbox Light Tray Harness	1
10	7894000004	Tie Strap	6

# TOOLBOX TOP STORAGE TRAY AND MARKER LIGHTS

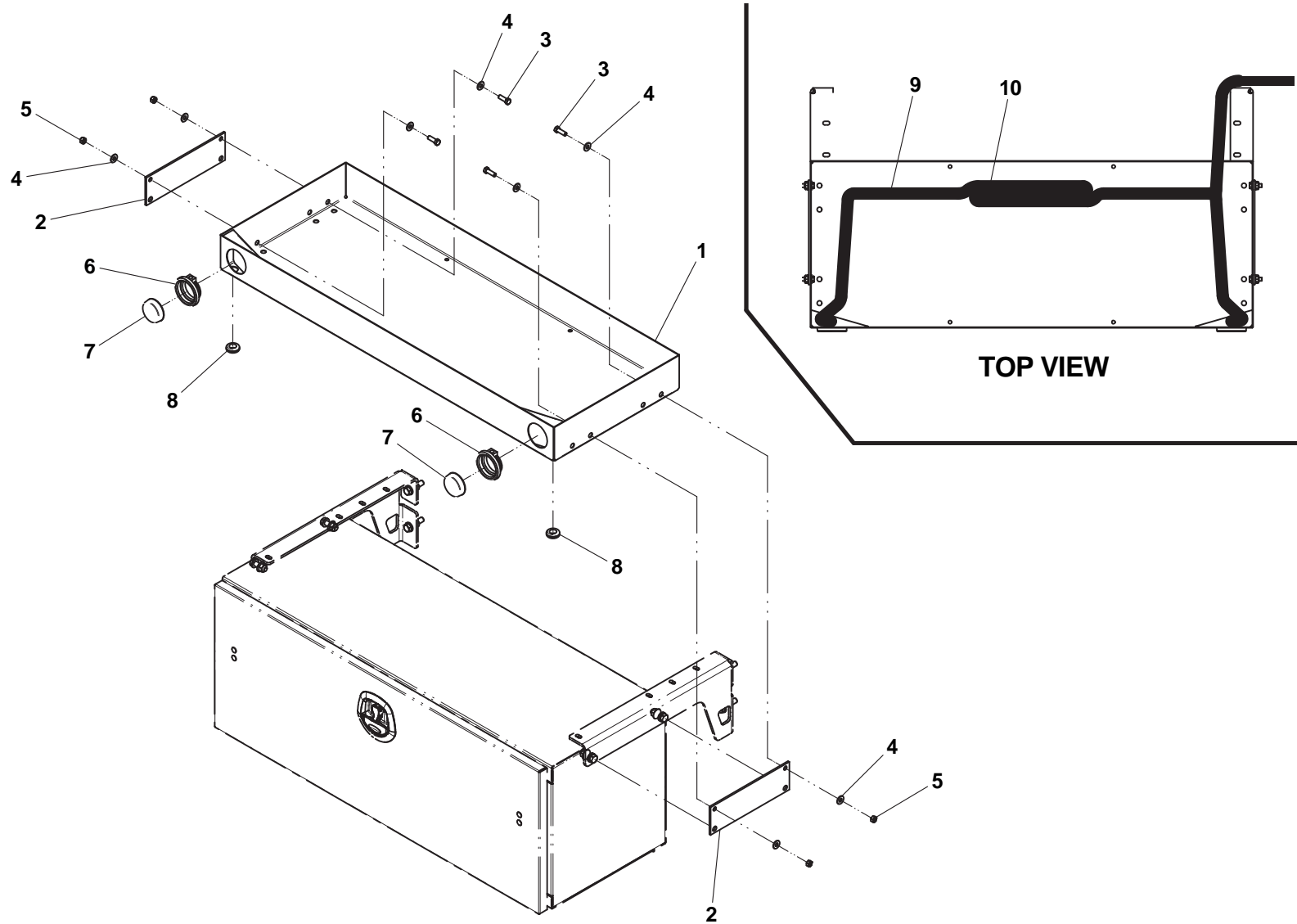

**DUAL CONTROLS - 3 BANK**

ITEM	PART NO.	DESCRIPTION	QTY	ITEM	PART NO.	DESCRIPTION	QTY
1	4263000431	Channel	1	29	7949000054	Washer, 0.34" ID	8
2	7950180161	Flatwasher, 0.50" ID	4	30	7330000648	Control Panel, LH	1
3	7660182601	Locknut, 0.50"-13NC	4	31	7330000649	Control Panel, RH	1
4	4263000430	Channel	1	32	7759000006	Pop Rivet	8
5	7790151253	Screw, 0.31"-18NC x 0.75"	12	33	7590000087	Lamp	2
6	3935000111	Control Valve	1	34	7791060872	Screw, #6 x 0.50"	4
	3935000115	Control Valve (with tilt relief)		35	7280000007	Wire Clip	11
7	7111161050	Capscrew, 0.38"-16NC x 1.25"	4	36	4606000217	Lug	4
8	7950160161	Flatwasher, 0.38" ID	4	37	7560000007	Control Hood, RH	1
9	7660162601	Locknut, 0.38"-16NC	4	38	7470000023	Gauge	1
10	4763000280	Control Rod	3	39	7661000057	Jam Nut, M5	2
11	4763000279	Control Rod	3				
12	7690101200	Clevis Pin	3				
13	7691000056	Cotter Pin	3				
14	7115150850	Capscrew, 0.31"-18NC x 1.00"	9				
15	7949000011	Flatwasher, 0.31" ID	9				
16	4831000069	Spacer	9				
17	7660152601	Locknut, 0.31"-18NC	17				
18	Not Required						
19	7115150664	Carriage Bolt, 0.31"-18NC x 0.75"	8				
20	7950150000	Washer, 0.31" ID	8				
21	7691000064	Pin	2				
22	7754000009	Retaining Ring	4				
23	7551000018	Control Handle	2				
24	7551000020	Control Handle	2				
25	7551000021	Control Handle	2				
26	4211000001	Bushing	4				
27	7950220141	Flatwasher, 0.75" ID	4				
28	7560000008	Control Hood, LH	1				

# DUAL CONTROLS - 3 BANK

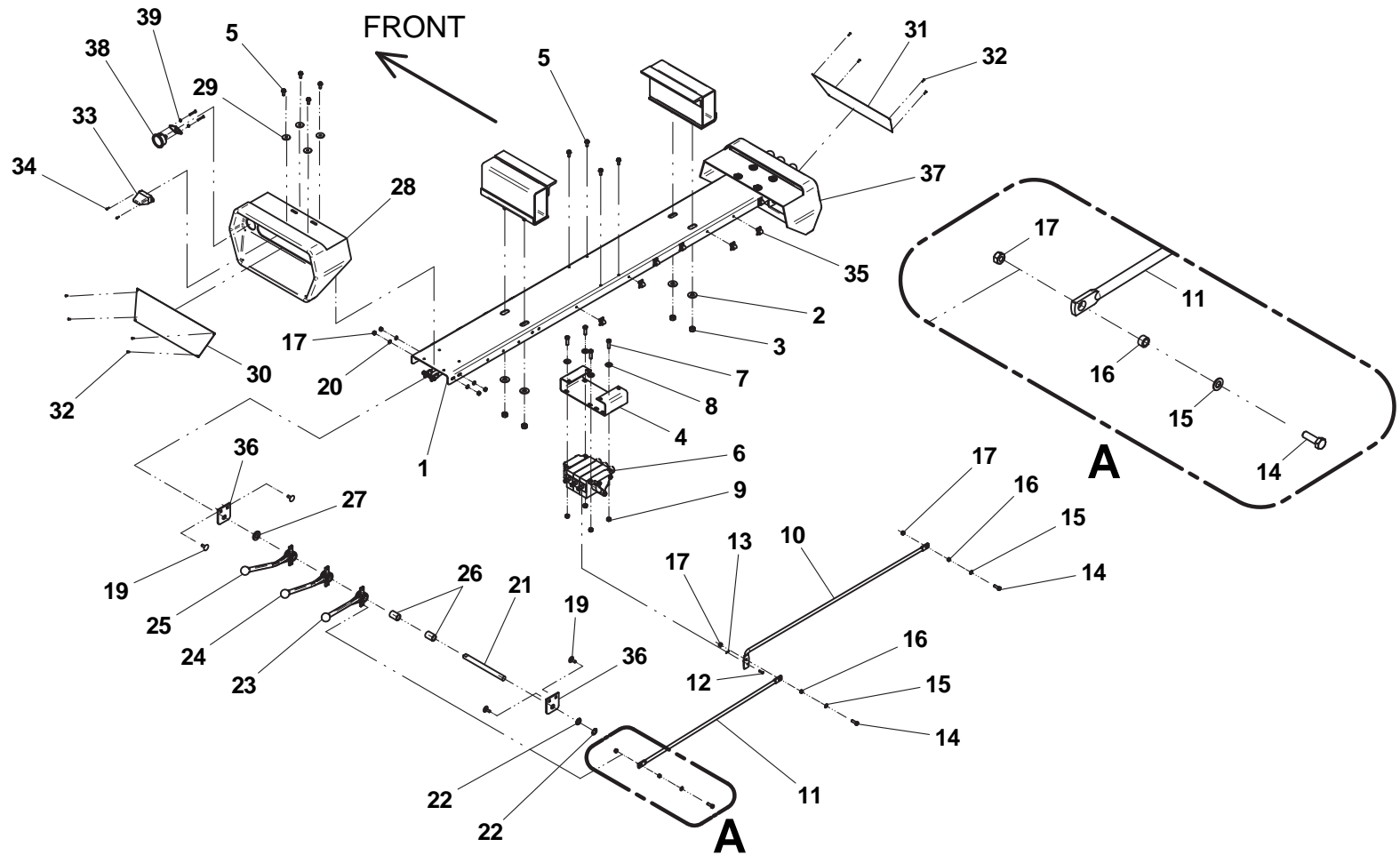

**DUAL CONTROLS - 4 BANK**

ITEM	PART NO.	DESCRIPTION	QTY	ITEM	PART NO.	DESCRIPTION	QTY
1	4263000431	Channel	1	30	7330000650	Control Panel, LH (stabilizer)	1
2	7950180161	Flatwasher, 0.50" ID	4		7330000648	Control Panel, LH (hydraulic tow option)	
3	7660182601	Locknut, 0.50"-13NC	4	31	7330000651	Control Panel, RH (stabilizer)	1
4	4263000430	Channel	1		7330000649	Control Panel, RH (hydraulic tow option)	
5	7790151253	Screw, 0.31"-18NC x 0.75"	12	32	7759000006	Pop Rivet	8
6	3935000112	Control Valve	1	33	7590000087	Lamp	2
	3935000116	Control Valve (with tilt relief)		34	7791060872	Screw, #6 x 0.50"	4
7	7111161050	Capscrew, 0.38"-16NC x 1.25"	4	35	7280000007	Wire Clip	11
8	7950160161	Flatwasher, 0.38" ID	4	36	4606000217	Lug	4
9	7660162601	Locknut, 0.38"-16NC	4	37	7560000007	Control Hood, RH	1
10	4763000280	Control Rod	4	38	7470000023	Gauge	1
11	4763000279	Control Rod	4	39	7661000057	Jam Nut, M5	2
12	7690101200	Clevis Pin	4				
13	7691000056	Cotter Pin	4				
14	7115150850	Capscrew, 0.31"-18NC x 1.00"	12				
15	7949000011	Flatwasher, 0.31" ID	12				
16	4831000069	Spacer	12				
17	7660152601	Locknut, 0.31"-18NC	20				
18	Not Required						
19	7115150664	Carriage Bolt, 0.31"-18NC x 0.75"	8				
20	7950150000	Washer, 0.31" ID	8				
21	7691000064	Pin	2				
22	7754000009	Retaining Ring	4				
23	7551000018	Control Handle	2				
24	7551000020	Control Handle	4				
25	7551000021	Control Handle	2				
26	4211000001	Bushing	2				
27	7950220141	Flatwasher, 0.75" ID	2				
28	7560000008	Control Hood, LH	1				
29	7949000054	Washer, 0.34" ID	8				



# DUAL CONTROLS - 4 BANK

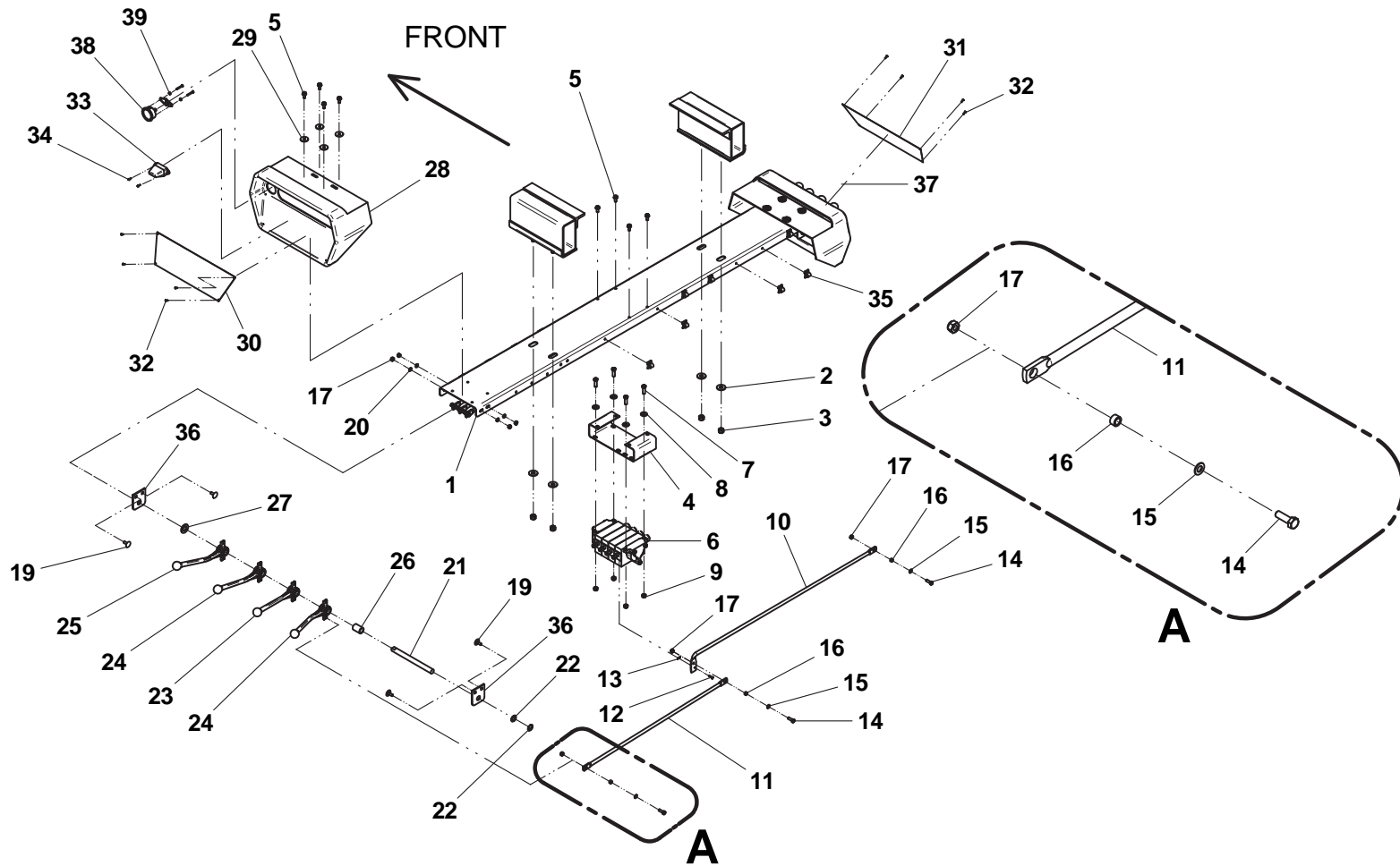

**DUAL CONTROLS - 5 BANK**

ITEM	PART NO.	DESCRIPTION	QTY	ITEM	PART NO.	DESCRIPTION	QTY
1	4263000431	Channel - Standard	1	29	7330000650	Control Panel, LH (stabilizer)	1
	4263000776	Channel - Galvanized			7330000648	Control Panel, LH (IRL)	
2	7950180161	Flatwasher, 0.50" ID	4	30	7330000651	Control Panel, RH (stabilizer)	1
3	7660182601	Locknut, 0.50"-13NC	4		7330000649	Control Panel, RH (IRL)	
4	4263000430	Channel - Standard	1	31	7759000006	Pop Rivet	8
	4263000622	Channel - Galvanized		32	7590000087	Lamp	2
5	7790151253	Screw, 0.31"-18NC x 0.75"	12	33	7791060872	Screw, #6 x 0.50"	4
6	3935000113	Control Valve	1	34	7280000007	Wire Clip	11
	3935000117	Control Valve (with tilt relief)		35	4606000217	Lug	4
7	7111161050	Capscrew, 0.38"-16NC x 1.25"	4	36	7560000007	Control Hood, RH	1
8	7950160161	Flatwasher, 0.38" ID	4	37	7470000023	Gauge	1
9	7660162601	Locknut, 0.38"-16NC	4	38	7661000057	Jam Nut, M5	2
10	4763000280	Control Rod	5				
11	4763000279	Control Rod	5				
12	7690101200	Clevis Pin	5				
13	7691000056	Cotter Pin	5				
14	7115150850	Capscrew, 0.31"-18NC x 1.00"	15				
15	7949000011	Flatwasher, 0.31" ID	15				
16	4831000069	Spacer	15				
17	7660152601	Locknut, 0.31"-18NC	23				
18	Not Required						
19	7115150664	Carriage Bolt, 0.31"-18NC x 0.75"	8				
20	7950150000	Washer, 0.31" ID	8				
21	7691000064	Pin	2				
22	7754000009	Retaining Ring	4				
23	7551000018	Control Handle	2				
24	7551000020	Control Handle	4				
25	7551000021	Control Handle	4				
26	7950220141	Flatwasher, 0.75" ID	2				
27	7560000008	Control Hood, LH	1				
28	7949000054	Washer, 0.34" ID	8				

# DUAL CONTROLS - 5 BANK

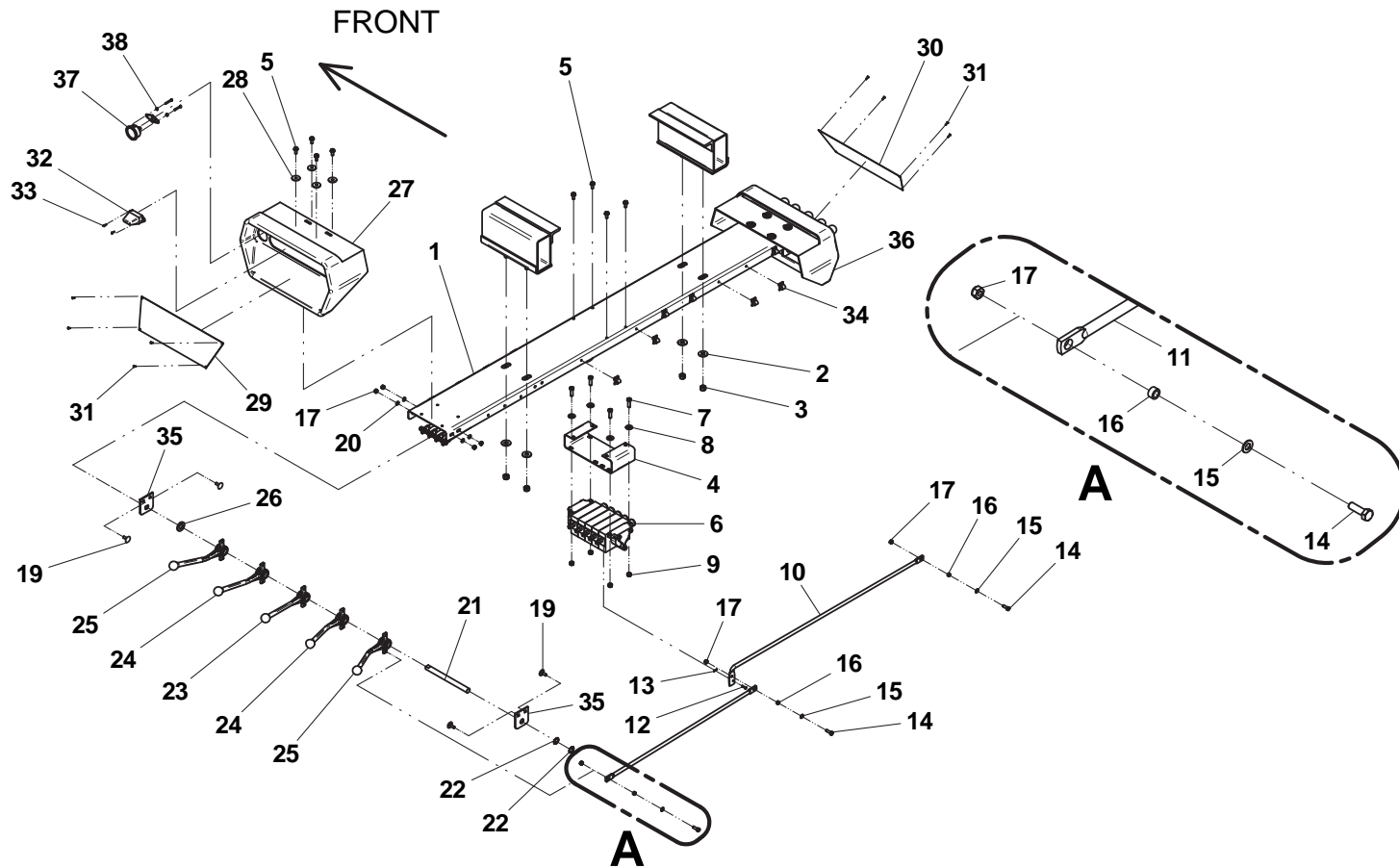

**DUAL CONTROLS - 6 BANK**

ITEM	PART NO.	DESCRIPTION	QTY	ITEM	PART NO.	DESCRIPTION	QTY
1	4263000434	Channel - Standard	1	29	7330000652	Control Panel, LH (manual grids)	1
	4263000813	Channel - Galvanized			7330000657	Control Panel, LH (hydraulic grids)	
2	7950180161	Flatwasher, 0.50" ID	4	30	7330000653	Control Panel, RH (manual grids)	1
3	7660182601	Locknut, 0.50"-13NC	4		7330000658	Control Panel, RH (hydraulic grids)	
4	4263000433	Channel - Standard	1	31	7759000006	Pop Rivet	8
	4263000819	Channel - Galvanized		32	7590000087	Lamp	2
5	7790151253	Screw, 0.31"-18NC x 0.75	12	33	7791060872	Screw, #6 x 0.50"	4
6	3935000114	Control Valve (manual grids)	1	34	7280000007	Wire Clip	11
	3935000166	Control Valve (hydraulic grids)		35	4606000217	Lug	4
	3935000118	Control Valve (manual grids & with tilt relief)		36	7560000007	Control Hood, RH	1
				37	7470000023	Gauge	1
7	7111161050	Capscrew, 0.38"-16NC x 1.25"	4	38	7661000057	Jam Nut, M5	2
8	7950160161	Flatwasher, 0.38" ID	4				
9	7660162601	Locknut, 0.38"-16NC	4				
10	4763000280	Control Rod	6				
11	4763000279	Control Rod	6				
12	7690101200	Clevis Pin	6				
13	7691000056	Cotter Pin	6				
14	7115150850	Capscrew, 0.31"-18NC x 1.00"	18				
15	7949000011	Flatwasher, 0.31" ID	18				
16	4831000069	Spacer	18				
17	7660152601	Locknut, 0.31"-18NC	26				
18	Not Required						
19	7115150664	Carriage Bolt, 0.31"-18NC x 0.75"	8				
20	7950150000	Washer, 0.31" ID	8				
21	7691000065	Pin	2				
22	7754000009	Retaining Ring	4				
23	7551000019	Control Handle	4				
24	7551000020	Control Handle	4				
25	7551000021	Control Handle	4				
26	7950220141	Flatwasher, 0.75" ID	2				
27	7560000008	Control Hood, LH	1				
28	7949000054	Washer, 0.34" ID	8				

# DUAL CONTROLS - 6 BANK

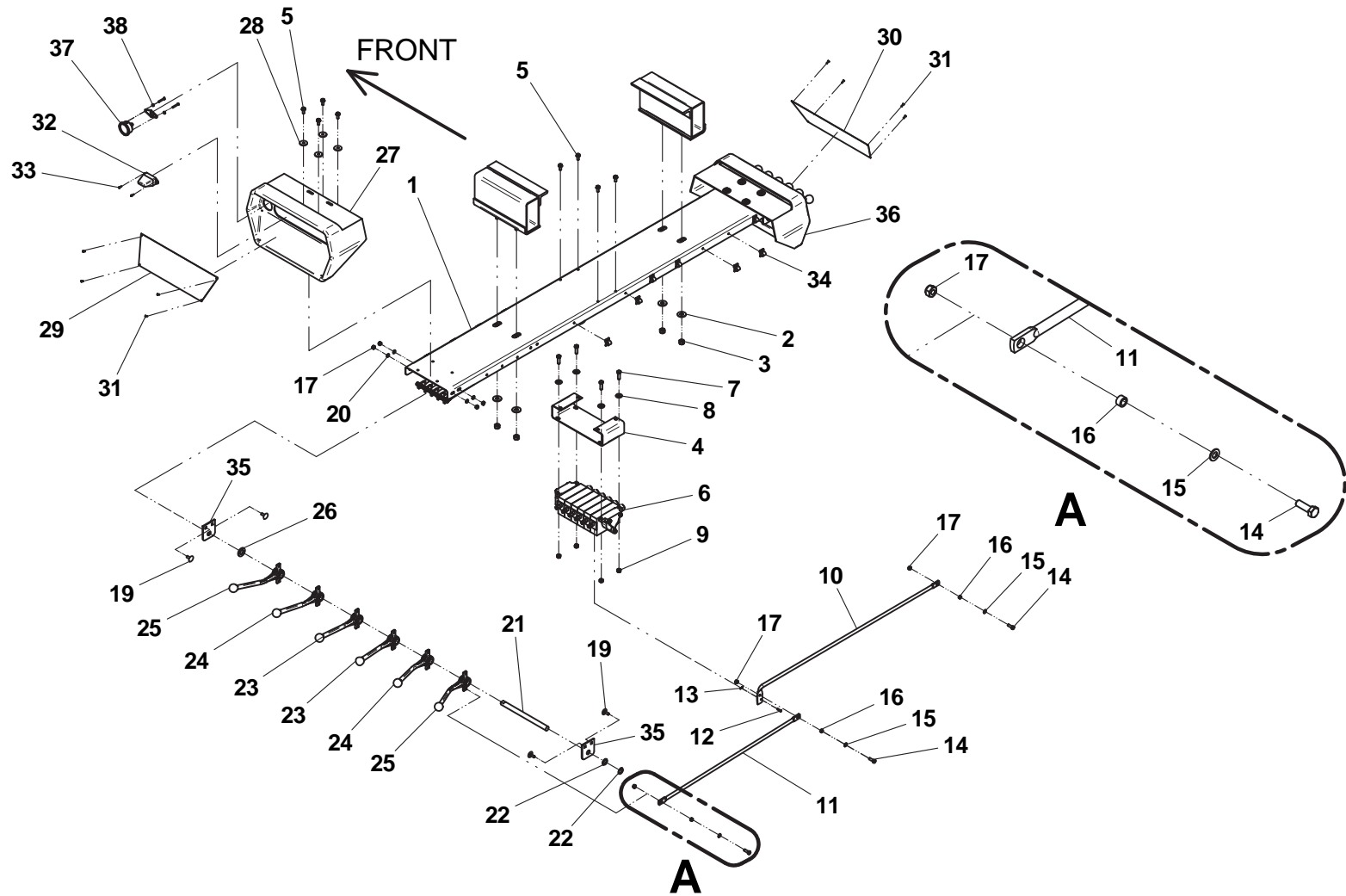

**DUAL CONTROLS - 7 BANK**

ITEM	PART NO.	DESCRIPTION	QTY	ITEM	PART NO.	DESCRIPTION	QTY
1	4263000463	Channel	1	31	7330000548	Control Panel, LH	1
2	7950180161	Flatwasher, 0.50" ID	6	32	7330000549	Control Panel, RH	1
3	7660182601	Locknut, 0.50"-13NC	6	33	7759000004	Pop Rivet	8
4	4263000464	Channel	1	34	7590000087	Lamp	2
5	7790151253	Screw, 0.31"-18NC x 0.75	12	35	7790101276	Screw, #6 x 0.50"	4
6	3935000150	Control Valve	1	36	7280000007	Wire Clip	11
7	7111161050	Capscrew, 0.38"-16NC x 1.25"	4	37	4606000217	Lug	4
8	7950160161	Flatwasher, 0.38" ID	4	38	7560000007	Control Hood, RH	1
9	7660162601	Locknut, 0.38"-16NC	4	39	7470000023	Gauge	1
10	4763000280	Control Rod	7	40	7661000057	Jam Nut, M5	2
11	4763000279	Control Rod	7				
12	7690101200	Clevis Pin	7				
13	7691000056	Cotter Pin	7				
14	7115150850	Capscrew, 0.31"-18NC x 1.00"	21				
15	7949000011	Flatwasher, 0.31" ID	21				
16	4831000069	Spacer	21				
17	7660152601	Locknut, 0.31"-18NC	29				
18	Not Required						
19	7115150664	Carriage Bolt, 0.31"-18NC x 0.75"	8				
20	7950150000	Washer, 0.31" ID	8				
21	7691000065	Pin	2				
22	7754000009	Retaining Ring	4				
23	7551000019	Control Handle	4				
24	7551000020	Control Handle	4				
25	7551000021	Control Handle	4				
26	7551000022	Control Handle	2				
27	7950220141	Flatwasher, 0.75" ID	2				
28	4211000001	Bushing	2				
29	3560000008	Control Hood, LH	1				
30	7949000054	Washer, 0.34" ID	2				

# DUAL CONTROLS - 7 BANK

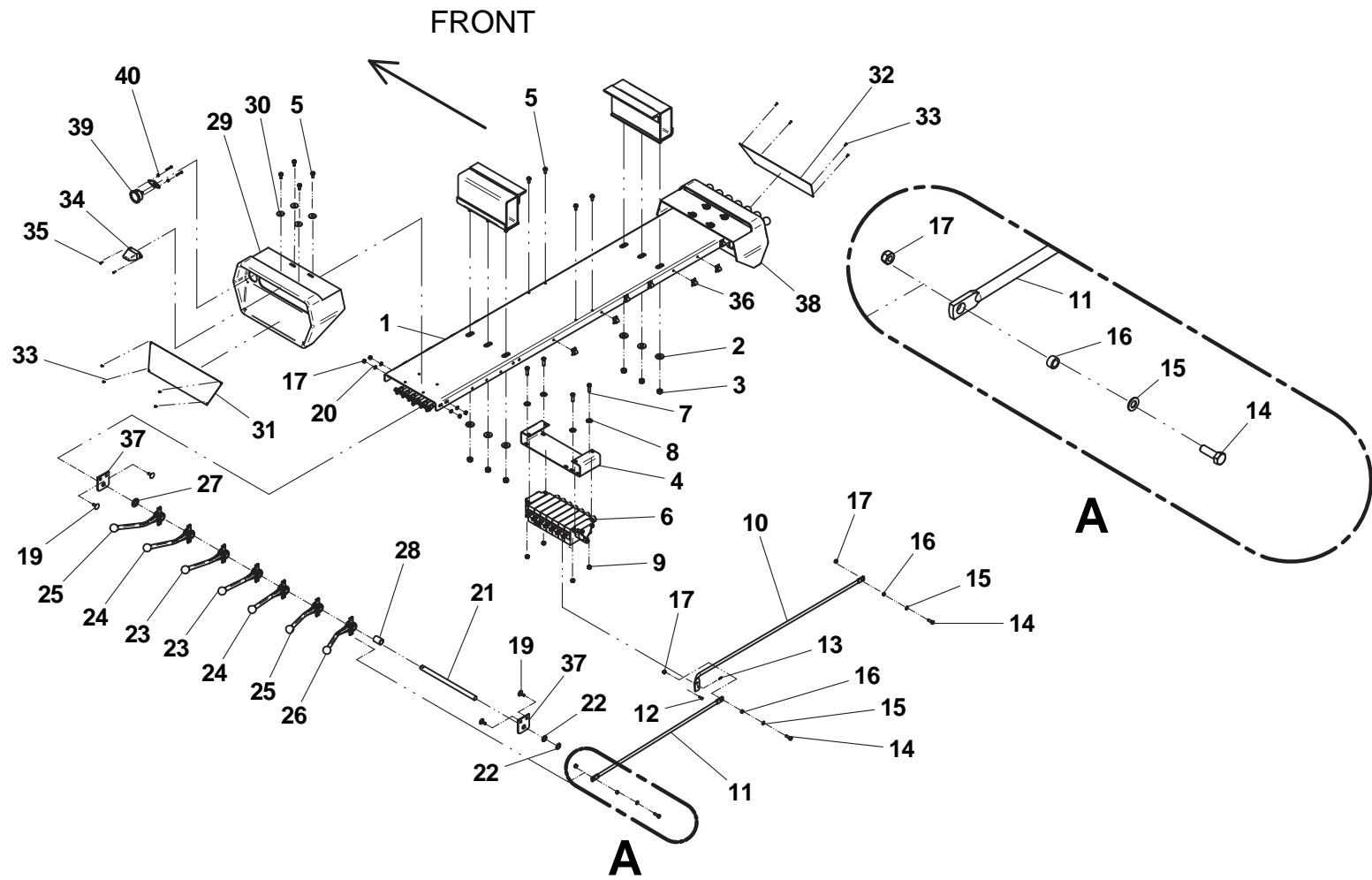

**HYDRAULIC COMPONENTS - STANDARD**

ITEM	PART NO.	DESCRIPTION	QTY	ITEM	PART NO.	DESCRIPTION	QTY
1	See Note 1	PTO	1	30	4569433115	Hose Assembly	1
2	7724000126	Pump	1	31	4569432115	Hose Assembly	1
3	7115181050	Capscrew	2	32	4567430118	Hose Assembly (19' deck)	2
4	7950180000	Lockwasher	2		4567430133	Hose Assembly (20' & 21' decks)	
5	7443000101	Adapter	1	33	7431000001^	Filter Element	1
6	7445081643	Adapter	1	34	7445040443	Adapter	1
7	7443000023	Elbow	1	35	4567112039	Hose Assembly	1
8	See Note 1	Supply Hose	1	36	7274000063	P-Clamp	1
9	7443000013	Nipple	1	37	7115140650	Capscrew, 0.25"-20NC x 0.75"	1
10	7274000002	Clamp	2	38	7950140141	Flatwasher, 0.25" ID	1
11	7430000003	Filter Assembly	1	39	7660142601	Locknut, .025"-20NC	1
12	7470000002	Gauge	1	40	4567120017	Hose Assembly	1
13	7443000319	Fitting	1	41	4567122038	Hose Assembly	1
14	7274000080	Clamp	2	42	7819000005	Sleeve - Rear (Dodge chassis only)	1
15	See Note 1	Pressure Hose Assembly	1	43	7819000013	Sleeve - Front (Dodge chassis only)	2
16	See Note 1	Return Hose	1				
17	7443000446	Adapter	1				
18	7445081045	Elbow	3				
19	7443000337	Check Valve (5 Ton Only)	1				
20	7445080843	Adapter	2				
21	7445060843	Adapter	3				
22	4567123044*	Hose Assembly	1				
23	4567122027*	Hose Assembly	1				
24	7445060645	Elbow	5				
25	7445060643	Adapter	7				
26	4567123042*	Hose Assembly	1				
27	4567120015*	Hose Assembly	1				
28	7935000306	Dual Counterbalance Valve	1				
29	4570000195*	Hose Assembly (Out Board Tilt Cylinders)	4				
	4270000198*	Hose Assembly (In Board Tilt Cylinders)					

\* included in Hose Kit, P/N 4577000008 for Out Board Tilt Cylinders  
& P/N 4577000009 for In Board Tilt Cylinders

^ also available in Filter Assembly, P/N 7430000003

Note 1: Varies depending on chassis, transmission , PTO type & deck length.  
Consult factory for part numbers.



# HYDRAULIC COMPONENTS - STANDARD

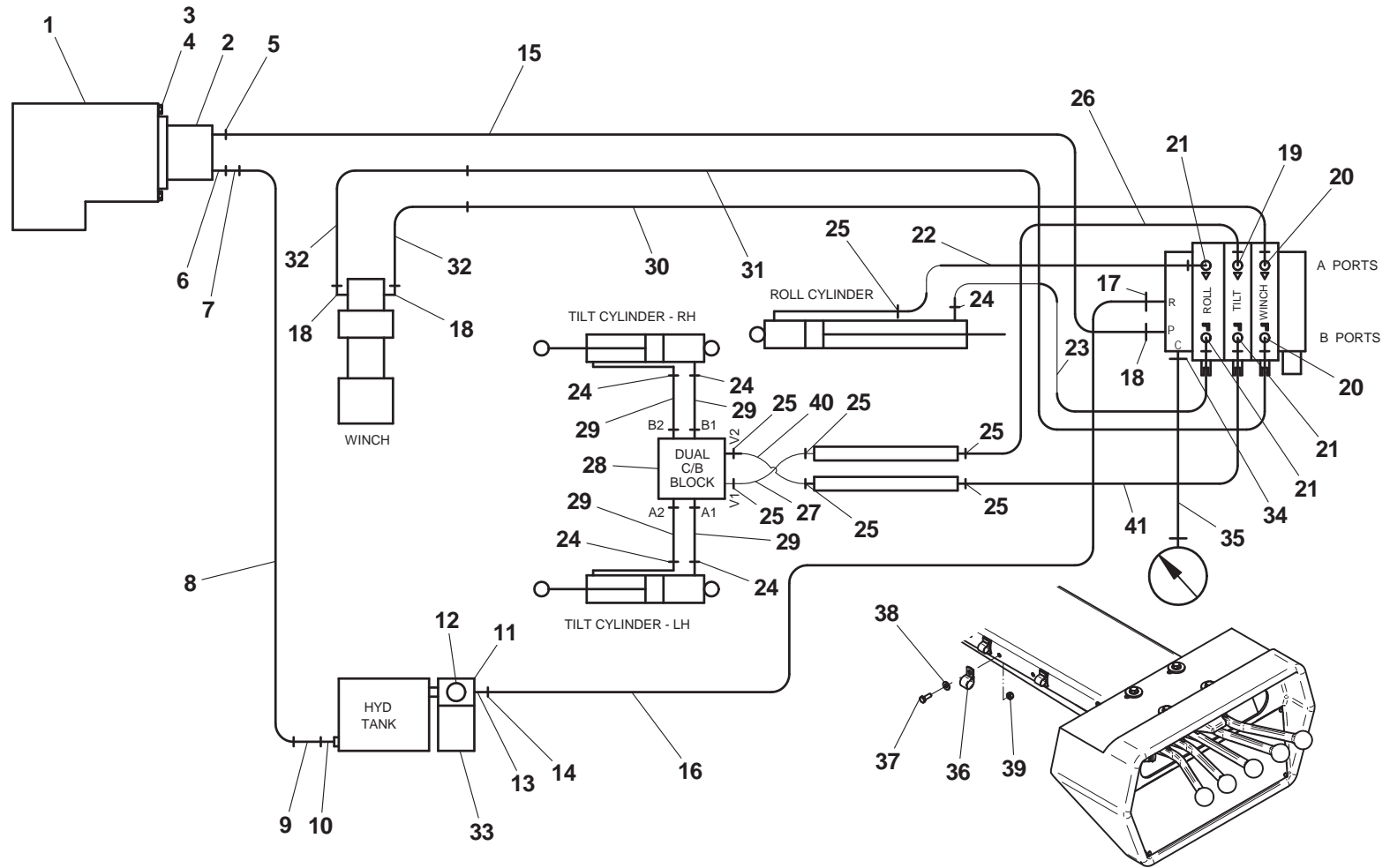

CLAMP FOR PRESSURE GAUGE HOSE, ITEM #35

Items #42 & #43, Sleeves, not shown

**HYDRAULIC COMPONENTS - STANDARD (HOSE TRACK)**

ITEM	PART NO.	DESCRIPTION	QTY
1	7904000007	Hose Track	1
2	4706003038	Plate	1
3	7114101618	Capscrew	4
4	7660102604	Locknut, #10-24NC	4
5	7274000038	Clamp	4
6	7274000039	Clamp Cover	2
7	7115151650	Capscrew, 0.31"-18NC x 2.00"	2
8	7950150161	Flatwasher, 0.31" ID	4
9	7660152601	Locknut, 0.31"-13NC (19' deck)	6
	7660152601	Locknut, 0.31"-13NC (20' & 21' decks)	7
10	7894000004	Tie Strap	10
11	7935000306	Counterbalance Valve	1
12	7115151850	Capscrew, 0.31"-18NC x 2.25"	2
13	7274000066	Double Clamp	4
14	7280000013	Clip	*

\* Quantity varies depending on deck length and deck type.

# HYDRAULIC COMPONENTS - STANDARD (HOSE TRACK)

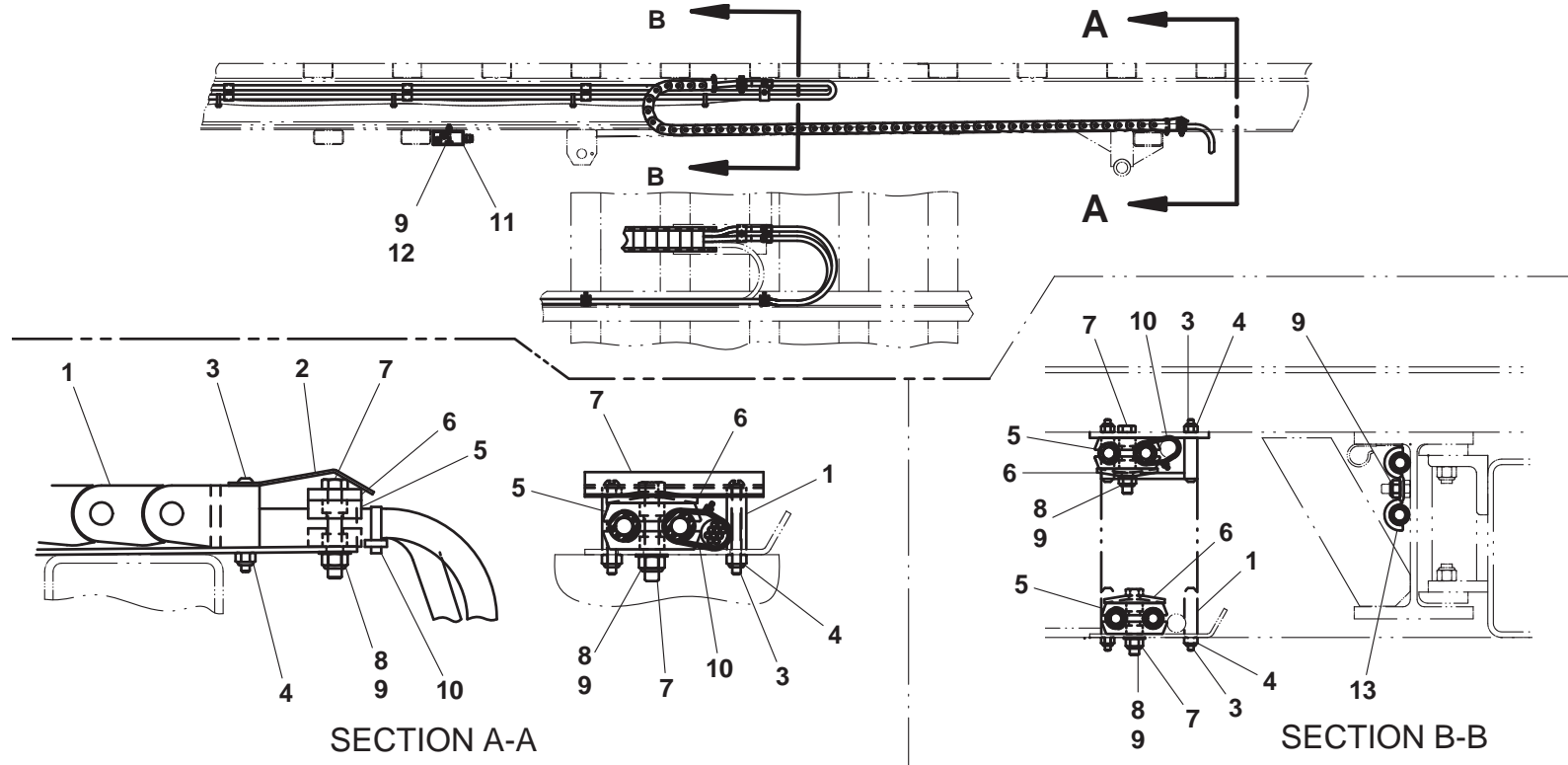

STEEL & WOOD  
DECK MAIN BEAM

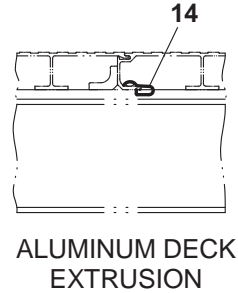

ALUMINUM DECK  
EXTRUSION

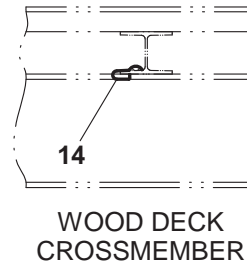

WOOD DECK  
CROSSMEMBER

**HYDRAULIC COMPONENTS - HOSE ROUTING / MOUNTING (FORD, GM & IHC)**

ITEM	PART NO.	DESCRIPTION	QTY
1	7274000076	Cast Frame Clamp	*
2	7785152420	Set Screw, 0.31"-18NC x 1.50"	*
3	7660152601	Locknut, 0.31"-18NC	*
4	7115151050	Capscrew, 0.31"-18NC x 1.25"	*
5	7950150161	Flatwasher, 0.31" ID	*
6	7274000040	Clamp	*
7	7274000041	Clamp	*
8	7274000042	Clamp	*
9	4706003844	Plate	*
10	7115151064	Carriage Bolt, 0.31"-18NC x 1.25"	*

\* Quantity varies depending on deck length and deck type

# HYDRAULIC COMPONENTS - HOSE ROUTING / MOUNTING (FORD, GM & IHC)

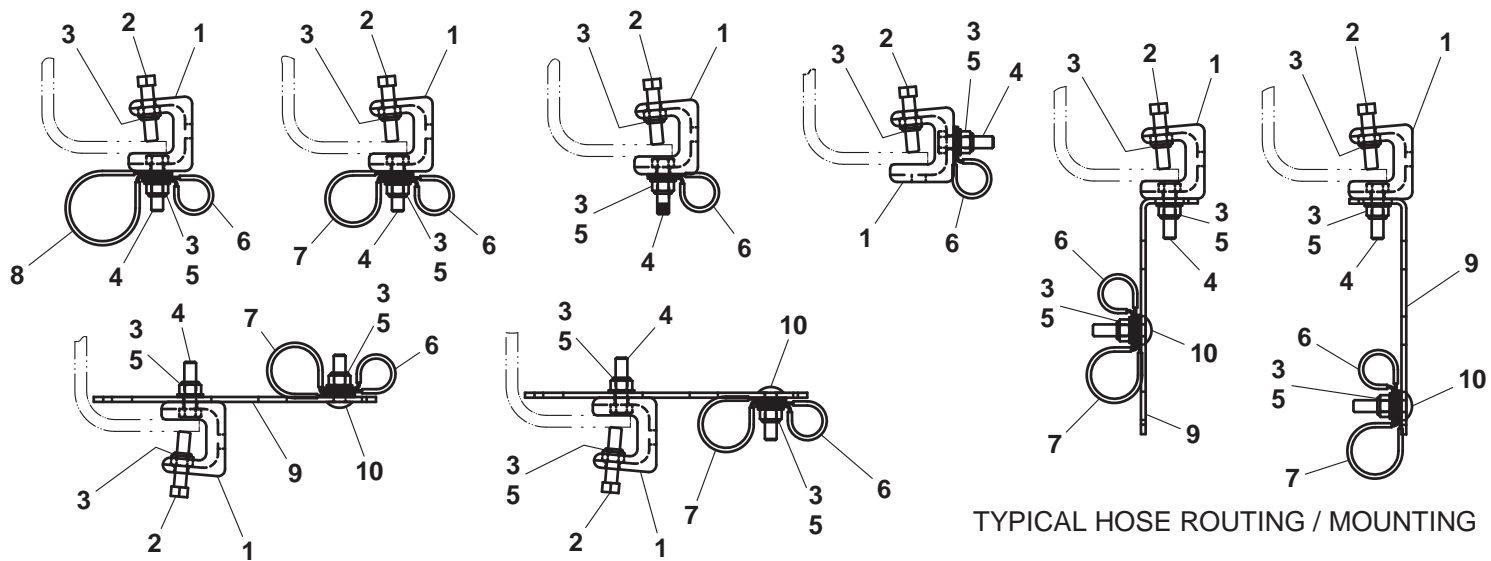
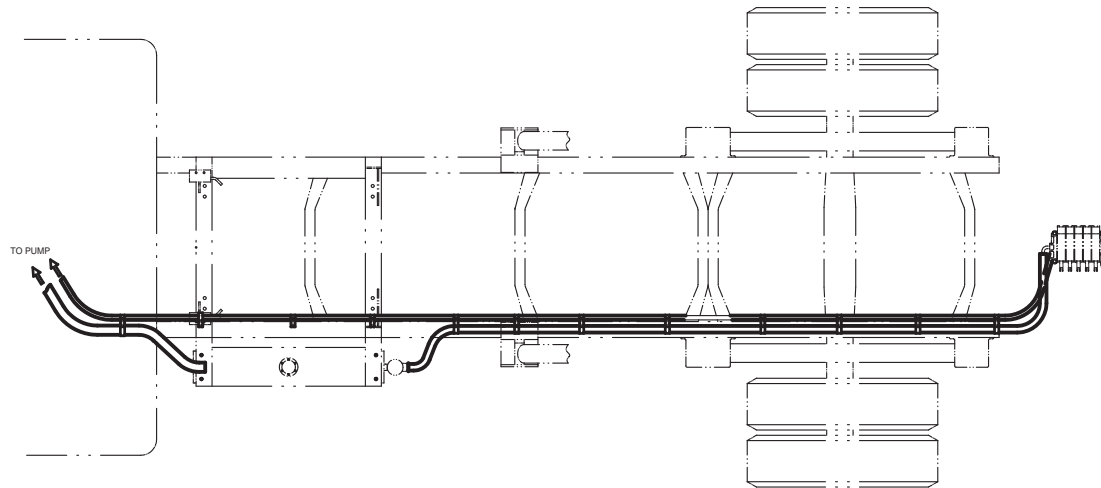

**HYDRAULIC COMPONENTS - HOSE ROUTING / MOUNTING (DODGE)**

ITEM	PART NO.	DESCRIPTION	QTY
1	7274000076	Cast Frame Clamp	*
2	7785152420	Set Screw, 0.31"-18NC x 1.50"	*
3	7660152601	Locknut, 0.31"-18NC	*
4	7115151050	Capscrew, 0.31"-18NC x 1.25"	*
5	7950150161	Flatwasher, 0.31" ID	*
6	7274000040	Clamp	*
7	7274000041	Clamp	*
8	7274000042	Clamp	*
9	4706003844	Plate	*
10	7115151064	Carriage Bolt, 0.31"-18NC x 1.25"	*

\* Quantity varies depending on deck length and deck type

# HYDRAULIC COMPONENTS - HOSE ROUTING / MOUNTING (DODGE)

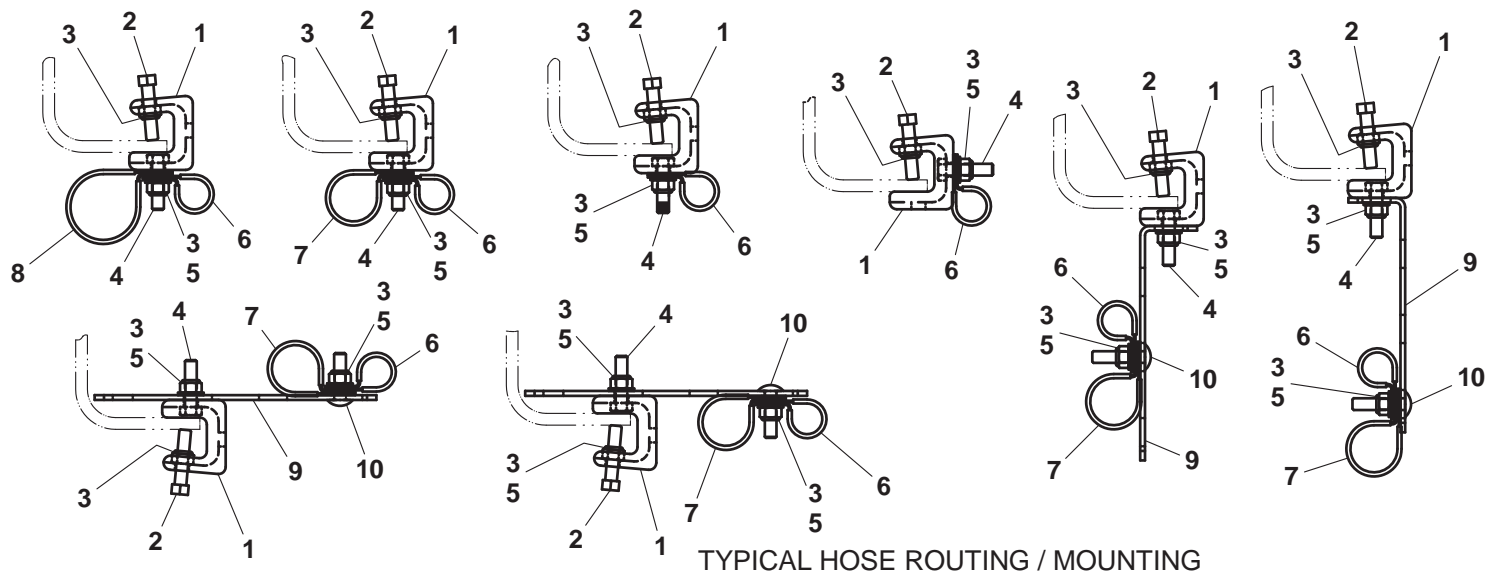
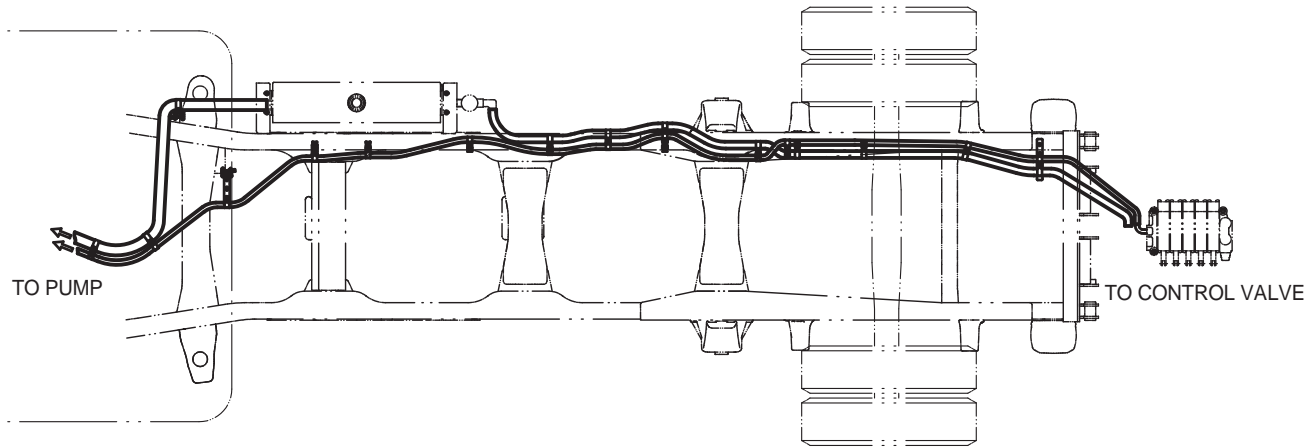

**HYDRAULIC COMPONENTS - IRL WHEEL LIFT WITH MANUAL GRIDS**

ITEM	PART NO.	DESCRIPTION	QTY
1	7443000129	Reducer	2
2	7445060648	Tee	4
3	4567123034*	Hose Assembly	2
4	4567122032*	Hose Assembly	2
5	7935000305	Counterbalance Valve	2
6	7445060645	Elbow	4
7	4567122014*	Hose Assembly	2
8	7445040843	Adapter	2
9	4567110032*	Hose Assembly	2
10	7445040446	Elbow	2

\* also available in Hose Kit, P/N 4577000002



# HYDRAULIC COMPONENTS - IRL WHEEL LIFT WITH MANUAL GRIDS

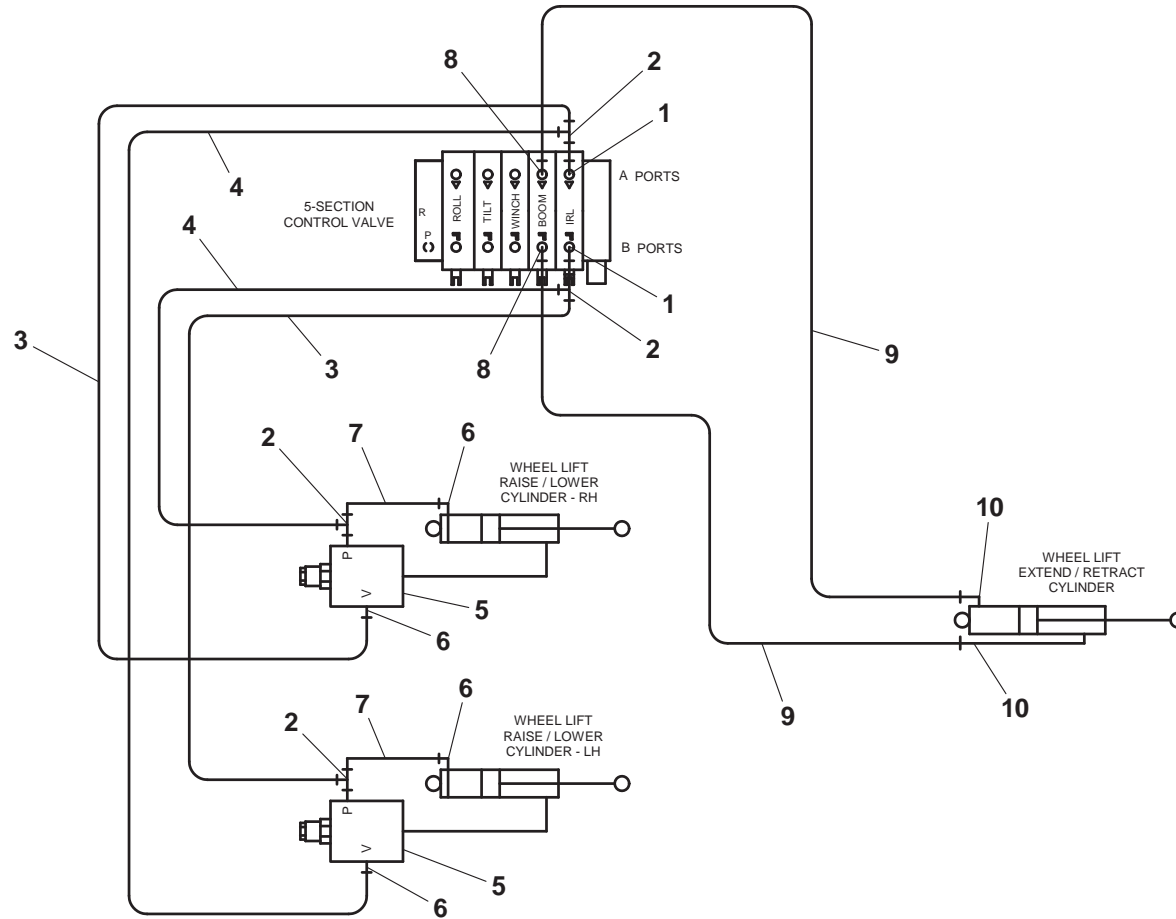

**HYDRAULIC COMPONENTS - IRL WHEEL LIFT WITH HYDRAULIC GRIDS**

ITEM	PART NO.	DESCRIPTION	QTY
1	7443000129	Reducer	2
2	7445060648	Tee	4
3	4567123034	Hose Assembly	2
4	4567122032	Hose Assembly	2
5	7935000305	Counterbalance Valve	2
6	7445060645	Elbow	4
7	4567122014	Hose Assembly (manual grids)	2
	4567122014	Hose Assembly (hyd grid - low frame)	
	4567122012	Hose Assembly (hyd grid - high frame)	
8	7445040843	Adapter	2
9	4567110032	Hose Assembly (manual grids)	2
	4567110042	Hose Assembly (hyd grid - low frame)	
	4567110038	Hose Assembly (hyd grid - high frame)	
10	7445040446	Elbow	2
11	7443040843	Adapter	2
12	4567110038	Hose Assembly (manual grids)	2
	4567110038	Hose Assembly (hyd grid - low frame)	
	4567110034	Hose Assembly (hyd grid - high frame)	
13	7445040445	Elbow	10
14	7912000237	Tube Assembly	2
15	4570000234	Hose Assembly	2
16	4619000013	Manifold	1
17	7445040443	Adapter	4
18	7912000184	Tube Assembly	4
19	4570000210	Hose Assembly	2
20	4570000211	Hose Assembly	2

# HYDRAULIC COMPONENTS - IRL WHEEL LIFT WITH HYDRAULIC GRIDS

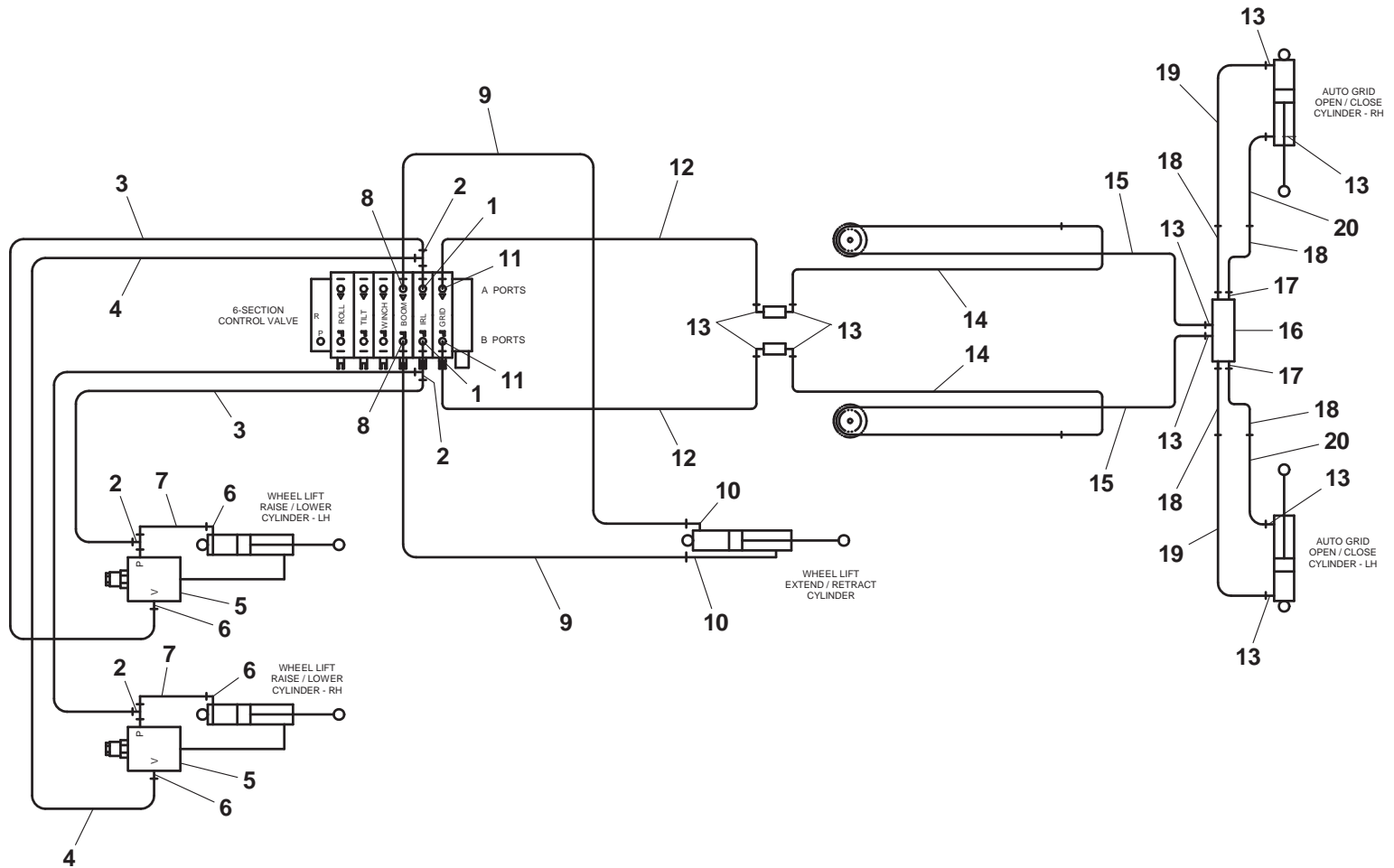

**HYDRAULIC COMPONENTS - ZOD WHEEL LIFT WITH MANUAL GRIDS**

ITEM	PART NO.	DESCRIPTION	QTY
1	7443000129	Reducer	2
2	7445060648	Tee	4
3	4567123034	Hose Assembly	2
4	4567122032	Hose Assembly	2
5	7935000305	Counterbalance Valve	2
6	7445060645	Elbow	4
7	4567122014	Hose Assembly	2
8	7445060843	Adapter	2
9	4567120025	Hose Assembly	2
10	7445060643	Adapter	4
11	7445040843	Adapter	2
12	4567110034	Hose Assembly	2
13	7445040446	Elbow	2

# HYDRAULIC COMPONENTS - ZOD WHEEL LIFT WITH MANUAL GRIDS

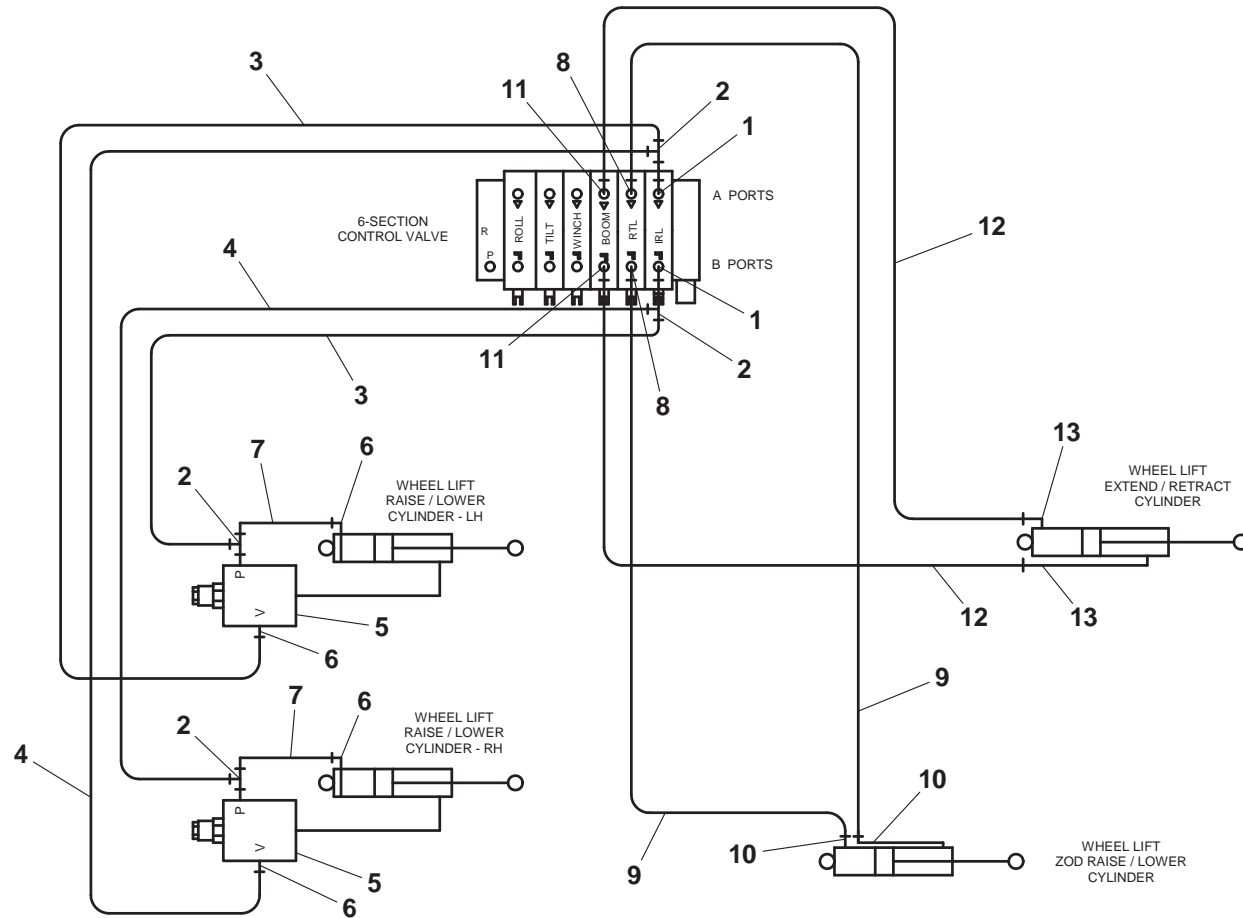

**HYDRAULIC COMPONENTS - ZOD WHEEL LIFT WITH HYDRAULIC GRIDS**

ITEM	PART NO.	DESCRIPTION	QTY
1	7443000129	Reducer	2
2	7445060648	Tee	4
3	4567123034	Hose Assembly	2
4	4567122032	Hose Assembly	2
5	7935000305	Counterbalance Valve	2
6	7445060645	Elbow	4
7	4567122014	Hose Assembly (manual grids)	2
	4567122014	Hose Assembly (hyd grid - low frame)	
	4567122012	Hose Assembly (hyd grid - high frame)	
8	7445060843	Adapter	2
9	4567120025	Hose Assembly	2
10	7443060643	Adapter	2
11	7445040843	Adapter	2
12	4567110032	Hose Assembly (manual L-grids)	2
	4567110042	Hose Assembly (hyd grid - low frame)	
	4567110038	Hose Assembly (hyd grid - high frame)	
13	7445040446	Elbow	2
14	7443040843	Adapter	2
15	4567110038	Hose Assembly (manual grids)	2
	4567110038	Hose Assembly (hyd grid - low frame)	
	4567110034	Hose Assembly (hyd grid - high frame)	
16	7445040445	Elbow	10
17	7912000237	Tube Assembly	2
18	4570000234	Hose Assembly	2
19	4619000013	Manifold	1
20	7445040443	Adapter	4
21	7912000184	Tube Assembly	4
22	4570000210	Hose Assembly	2
23	4570000211	Hose Assembly	2

# HYDRAULIC COMPONENTS - ZOD WHEEL LIFT WITH HYDRAULIC GRIDS

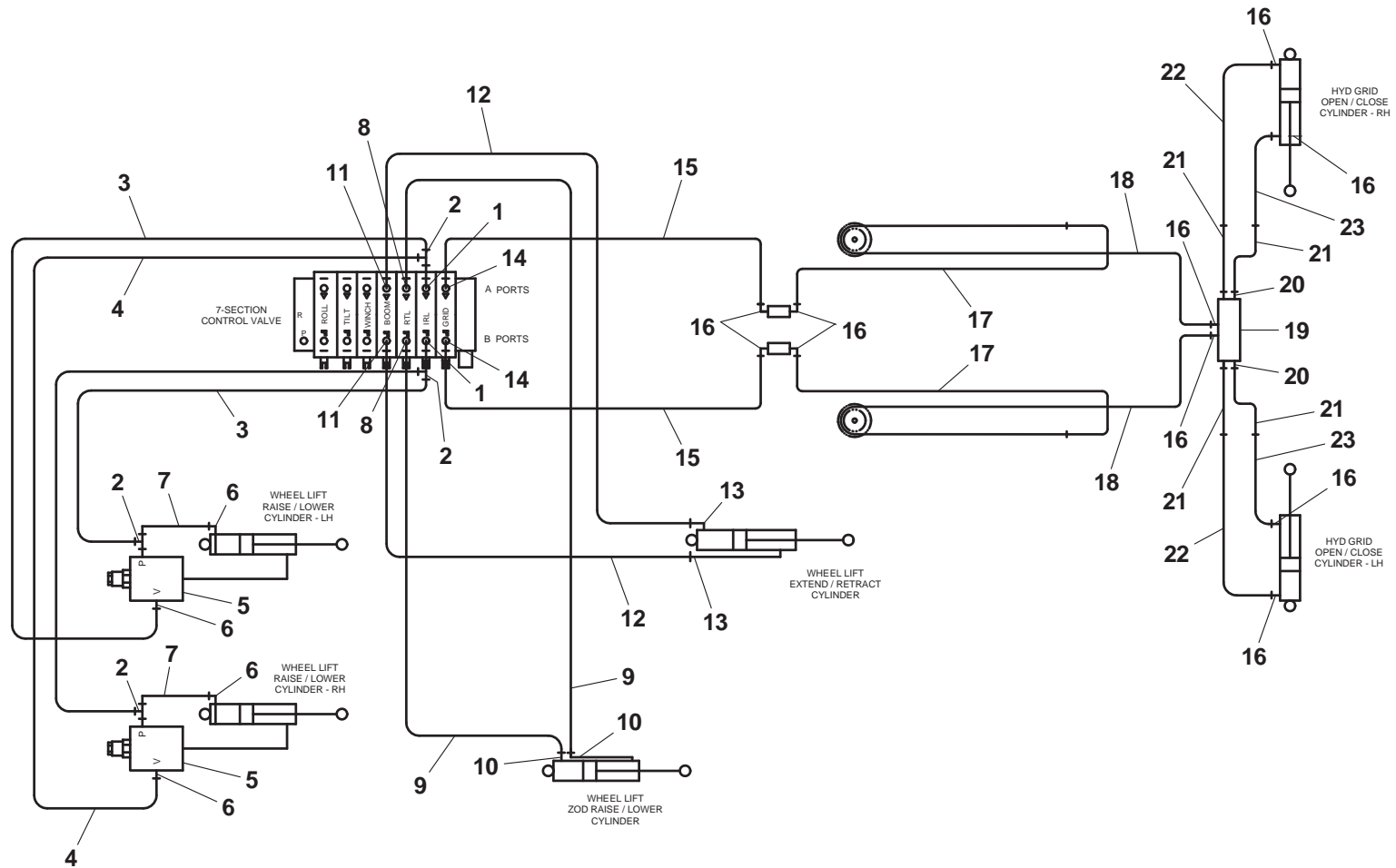

**HYDRAULIC COMPONENTS - HYDRAULIC REAR DOCK STABILIZER**

ITEM	PART NO.	DESCRIPTION	QTY
1	7445060843	Adapter	2
2	4567122017	Hose Assembly	2
3	7445060637	Tee	2
4	4567120016	Hose Assembly	2
5	4567120026	Hose Assembly	2
6	7445060645	Elbow	4



# HYDRAULIC COMPONENTS - HYDRAULIC REAR DOCK STABILIZER

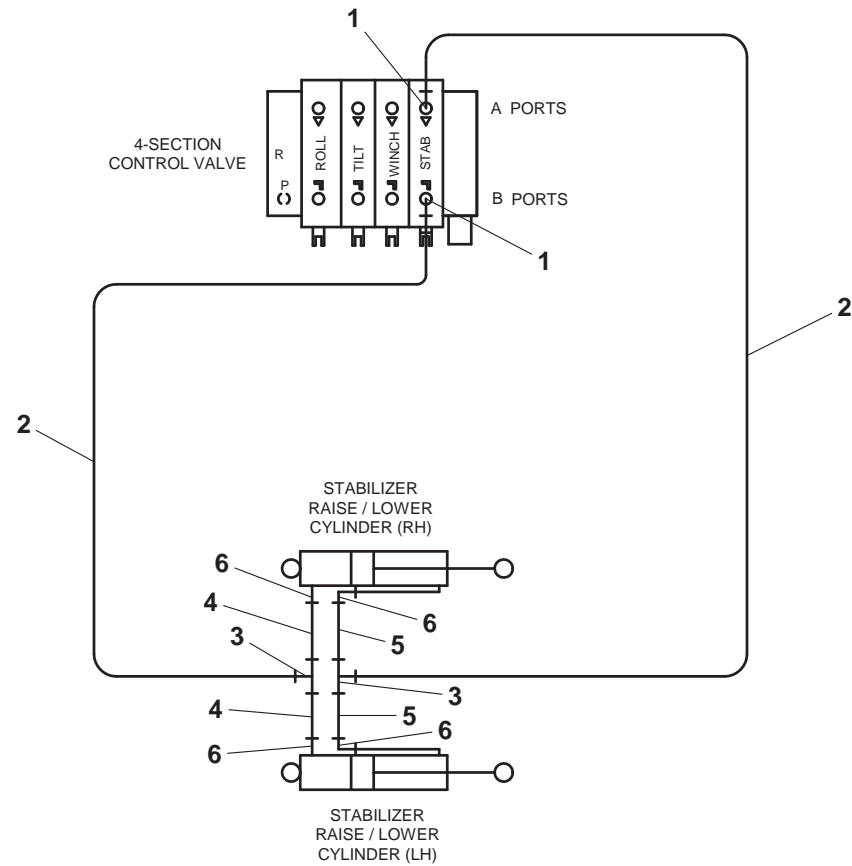

**HYDRAULIC COMPONENTS - STABILIZER W/ REESE HITCH RECEIVER OR PINTLE HITCH MTG PLT**

ITEM	PART NO.	DESCRIPTION	QTY
1	7445060845	Elbow	2
2	7443000030	Tee	2
3	4567122032	Hose Assembly	2
4	4567122050	Hose Assembly	2
5	7935000305	Counterbalance Valve	2
6	7445060648	Tee	2
7	7445060645	Elbow	4
8	4567122014	Hose Assembly	2

# HYDRAULIC COMPONENTS - STABILIZER W/ REESE HITCH RECEIVER OR PINTLE HITCH MTG PLT

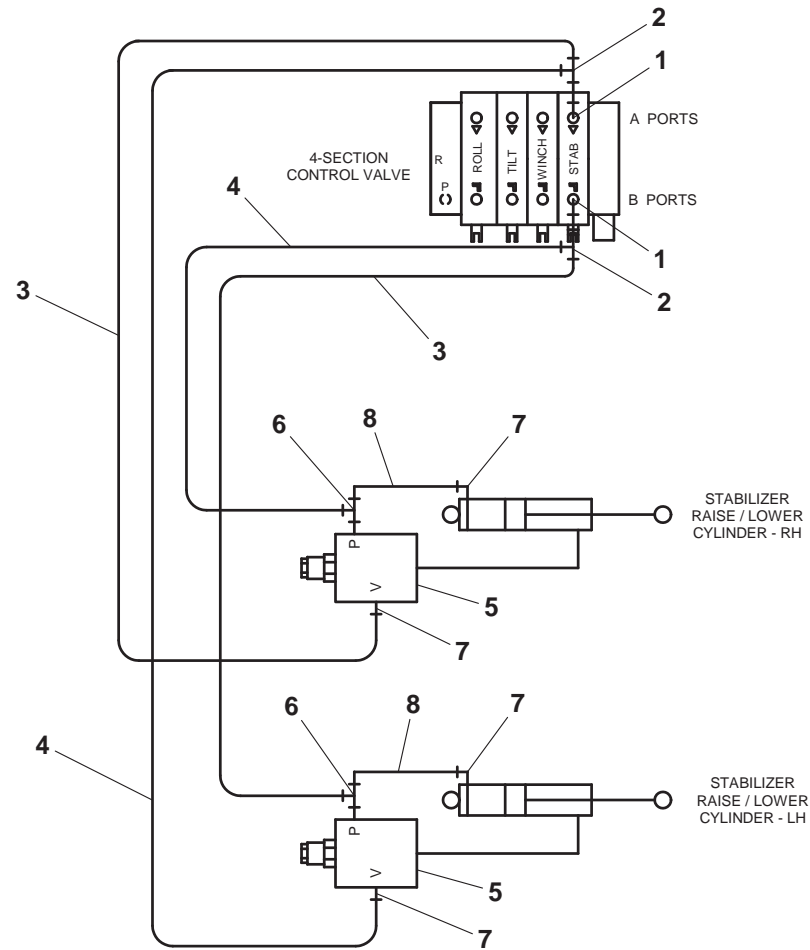

**HYDRAULIC COMPONENTS - STABILIZER W/ HYDRAULIC PINTLE HITCH MOUNTING PLATE**

ITEM	PART NO.	DESCRIPTION	QTY
1	7445060843	Adapter	2
2	7445060845	Elbow	2
3	7443000030	Tee	2
4	4567122032	Hose Assembly	2
5	4567122050	Hose Assembly	2
6	7935000305	Counterbalance Valve	2
7	7445060645	Elbow	4
8	7445060648	Tee	2
9	4567122014	Hose Assembly	2
10	4567120024	Hose Assembly	2
11	7445060643	Adapter	2

# HYDRAULIC COMPONENTS - STABILIZER W/ HYDRAULIC PINTLE HITCH MOUNTING PLATE

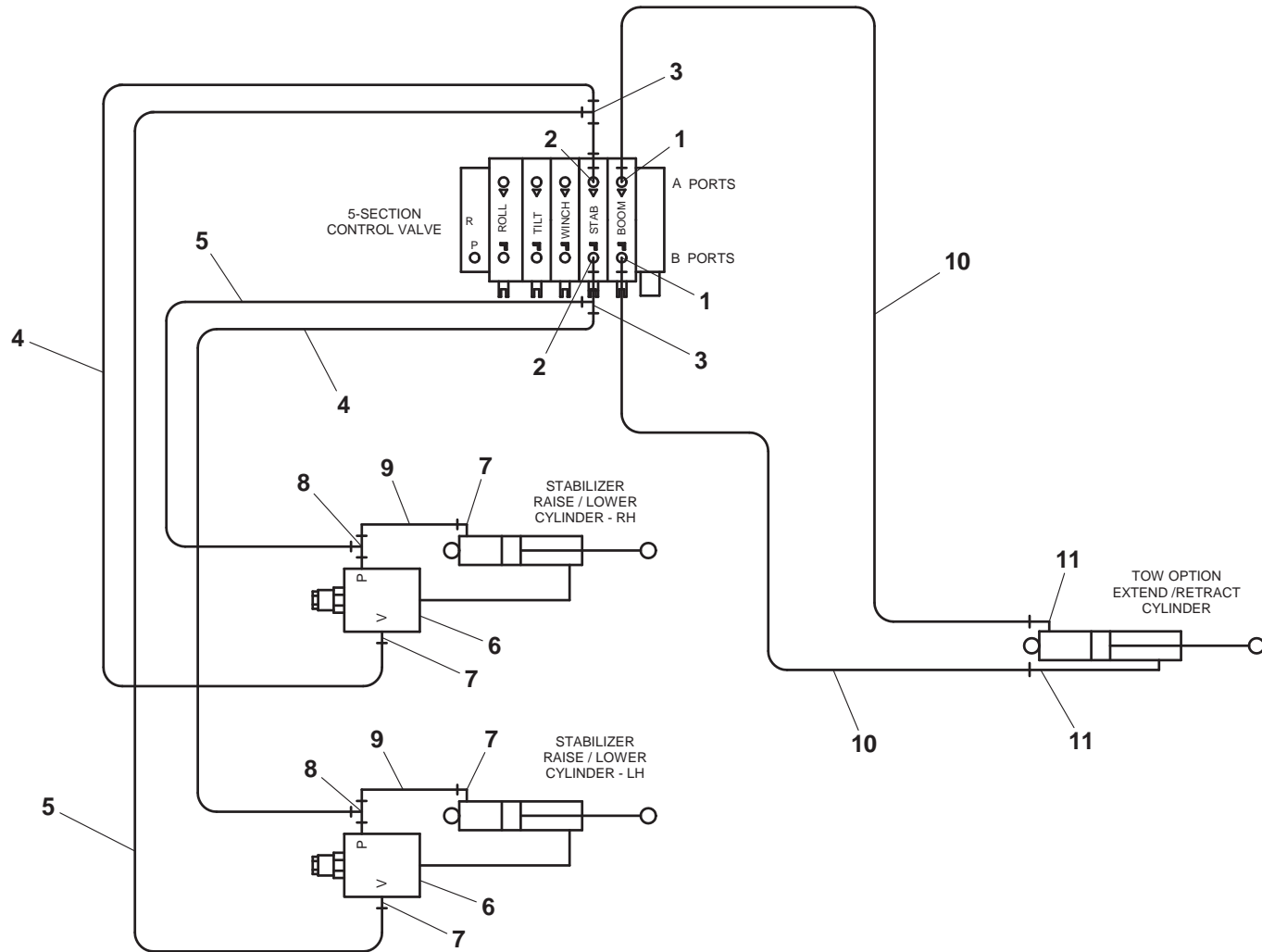

**HYDRAULIC COMPONENTS - IRL TOW OPTION**

ITEM	PART NO.	DESCRIPTION	QTY
1	7443000129	Reducer	2
2	7445060648	Tee	4
3	4567123034	Hose Assembly	2
4	4567122032	Hose Assembly	2
5	7935000305	Counterbalance Valve	2
6	7445060645	Elbow	4
7	4567122014	Hose Assembly	2
8	7445040843	Adapter	2
9	4567112042	Hose Assembly	2
10	7445040645	Elbow	2

# HYDRAULIC COMPONENTS - IRL TOW OPTION

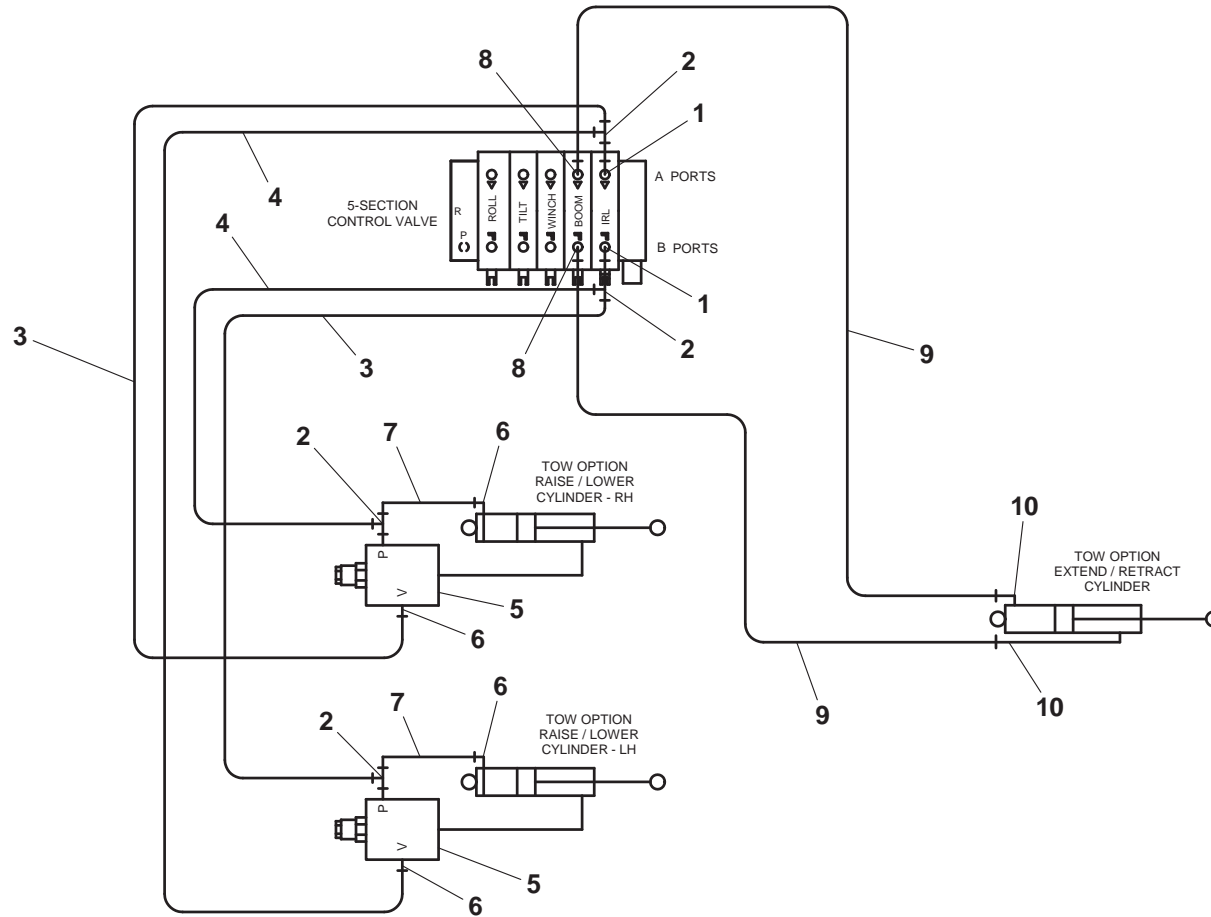

**HYDRAULIC COMPONENTS - HYDRAULIC EXTEND TOW OPTION**

ITEM	PART NO.	DESCRIPTION	QTY
1	7445040843	Adapter	2
2	4567112042	Hose Assembly	2
3	7445040645	Elbow	2



# HYDRAULIC COMPONENTS - HYDRAULIC EXTEND TOW OPTION

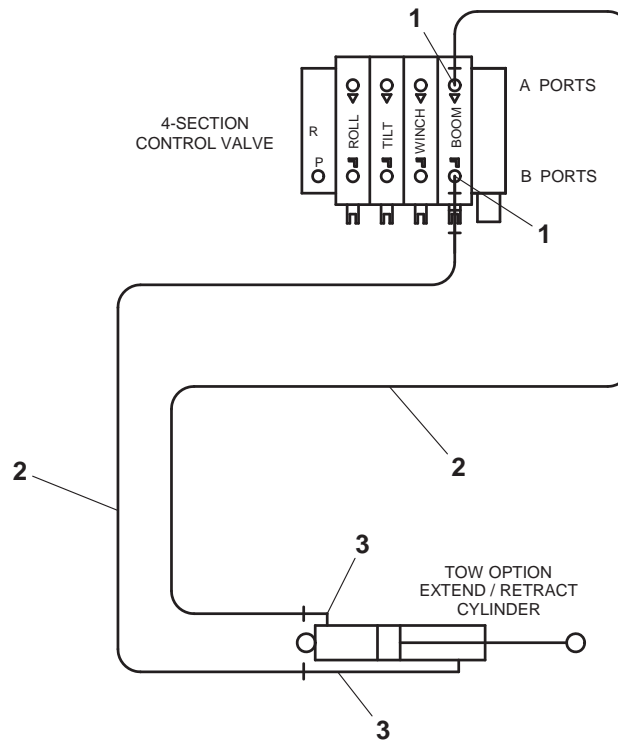

**ELECTRICAL COMPONENTS - STANDARD W/ BOLT-ON HEADBOARD**

ITEM	PART NO.	DESCRIPTION	QTY
1	7552000098	Subframe to Deck Harness	1
2	7552000074	Subframe to Cab Harness	1
3	7552000126	Subframe Harness	1
4	7552000177	Deck Harness	1
5	7552000166	Winch Lights Harness	1
6	7552000222	Work Lights on Headboard Harness	1
7	7345241902	Terminal	1
8	7457000004	Circuit Breaker	1
9	7790100856	Screw, #10 x 0.50"	2
10	7345221902	Terminal	2
11	7950100151	Flatwasher, 0.19" ID	2
12	7280000013	Clip	*
13	7577000194	Wiring Connector Kit (Ford & GMC chassis)	1
	7552000117	Wiring Connector Kit (UD chassis)	

\* Quantity varies depending on deck construction.

# ELECTRICAL COMPONENTS - STANDARD W/ BOLT-ON HEADBOARD

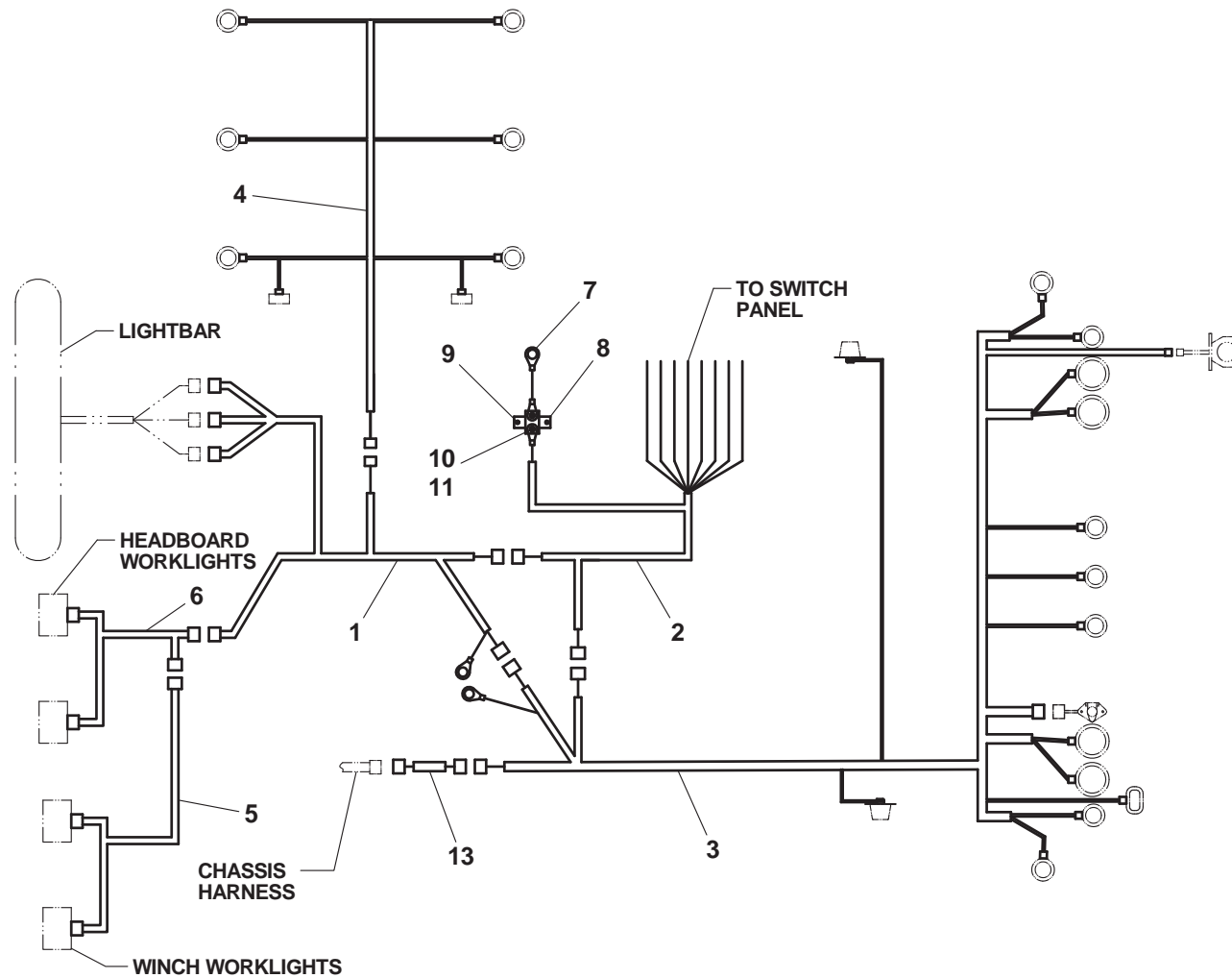

Item #12, Clip, not shown.

**ELECTRICAL COMPONENTS - STANDARD W/ STATIONARY HEADBOARD**

ITEM	PART NO.	DESCRIPTION	QTY
1	7552000204	Subframe to Cab Harness	1
2	7552000075	Subframe to Deck Harness	1
3	7552000126	Subframe Harness	1
4	7552000177	Deck Harness	1
5	7552000166	Winch Lights Harness	1
6	7345241902	Terminal	1
7	7457000004	Circuit Breaker	1
8	7790100856	Screw, #10 x 0.50"	2
9	7345221902	Terminal	2
10	7950100151	Flatwasher, 0.19" ID	2
11	7280000013	Clip	*
12	7577000194	Wiring Connector Kit	1

\* Quantity varies depending on deck construction.

# ELECTRICAL COMPONENTS - STANDARD W/ STATIONARY HEADBOARD

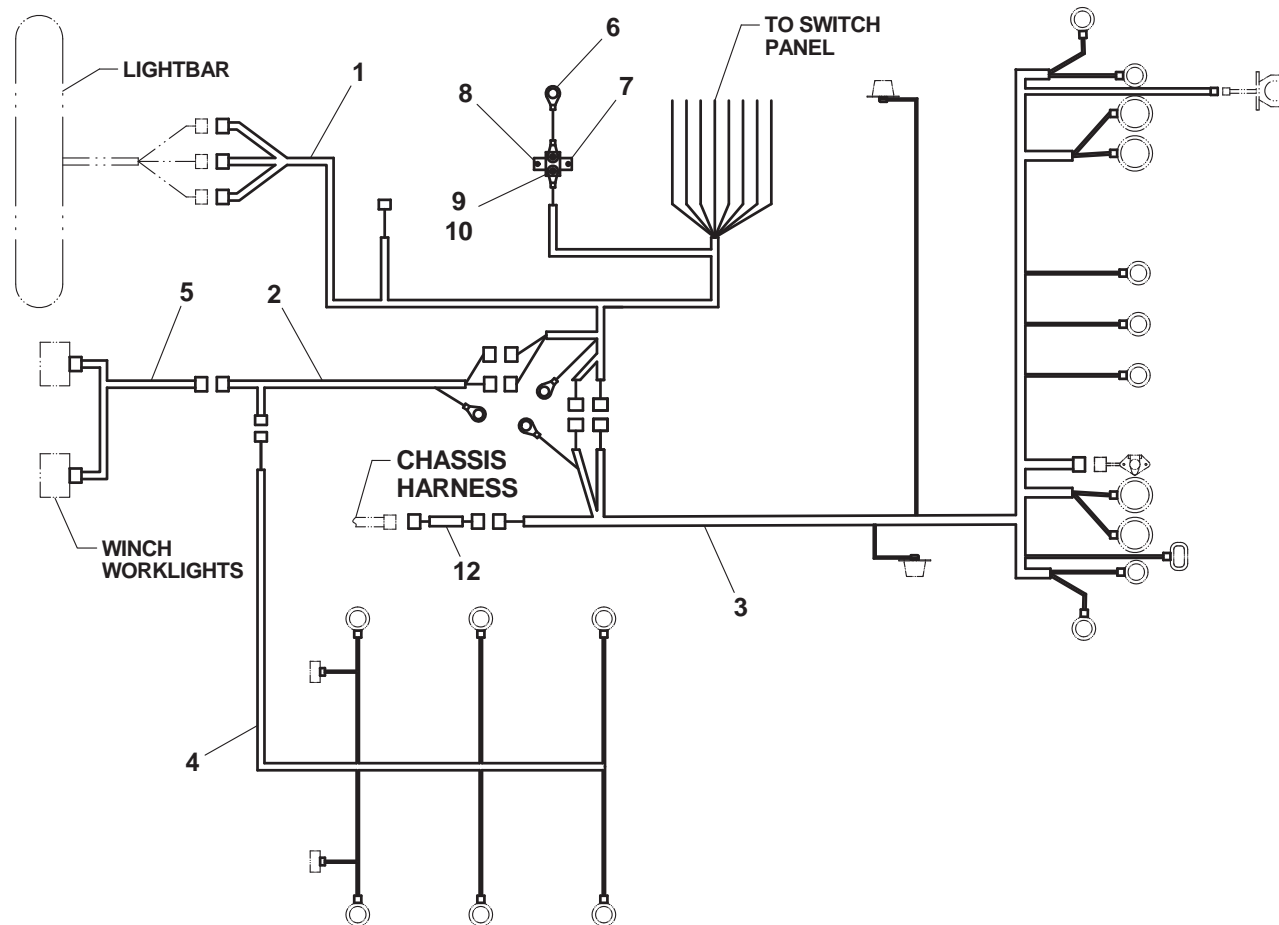

Item #11, Clip, not shown.

**DECK MARKER LIGHTS**

ITEM	PART NO.	DESCRIPTION	QTY
1	7493000009	Grommet	6
2	7590000342	Marker Light - Amber (LED)	4
3	7590000343	Marker Light - Red (LED)	2
4	7493000010	Grommet	2
5	7590000339	Marker Light - Amber (LED)	2

# DECK MARKER LIGHTS

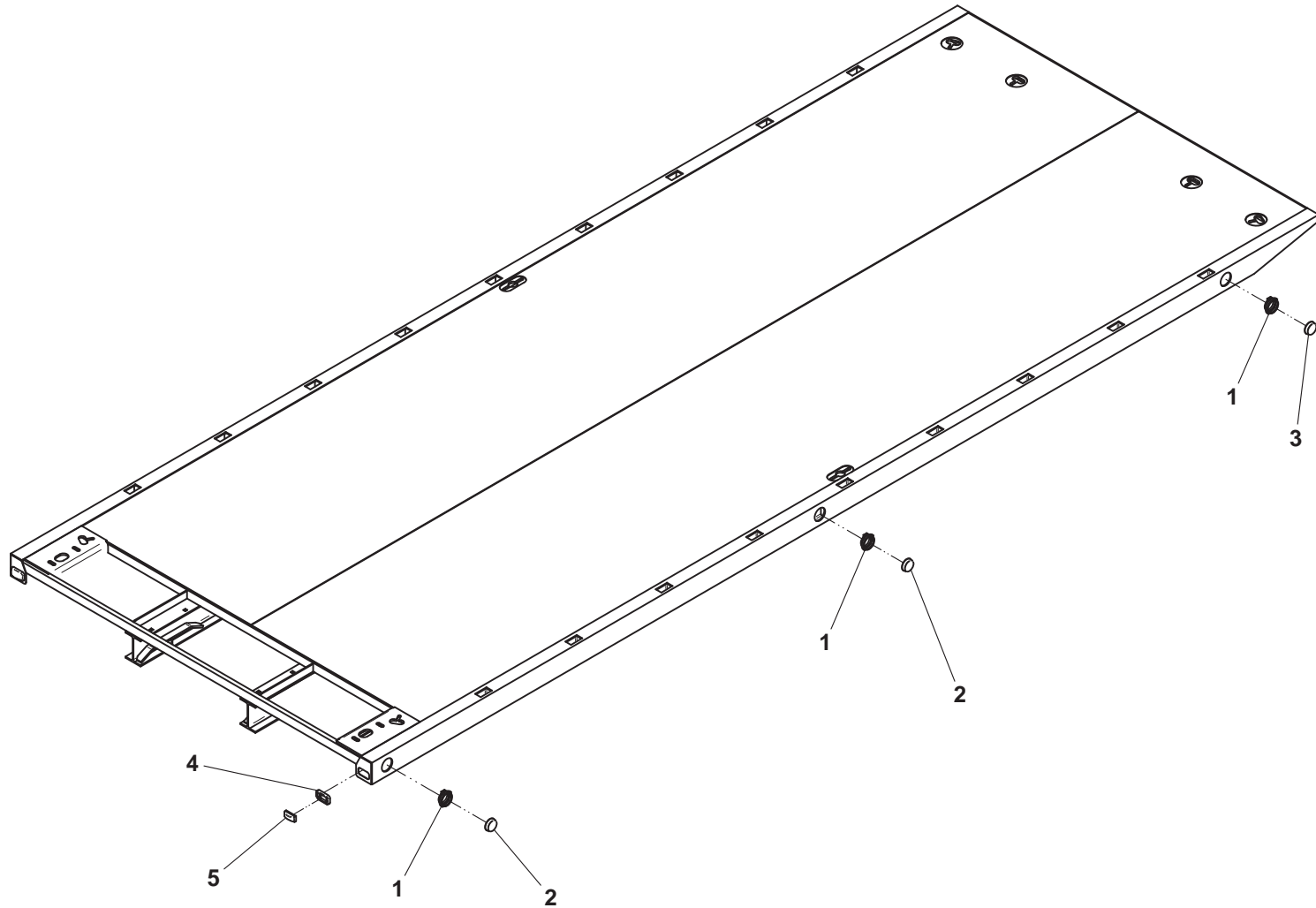

**HEADBOARD SIDE MARKER LIGHTS**

ITEM	PART NO.	DESCRIPTION	QTY
1	7493000009	Grommet (36" & 40" Headboard)	2
	7493000009	Grommet (45", 50" & 57" Headboard)	4
2	7590000342	Marker Light - Amber (LED) (36" & 40" Headboard)	2
	7590000342	Marker Light - Amber (LED) (45", 50" & 57" Headboard)	4
3	7552000409	Headboard to Cab Harness	1



# HEADBOARD SIDE MARKER LIGHTS

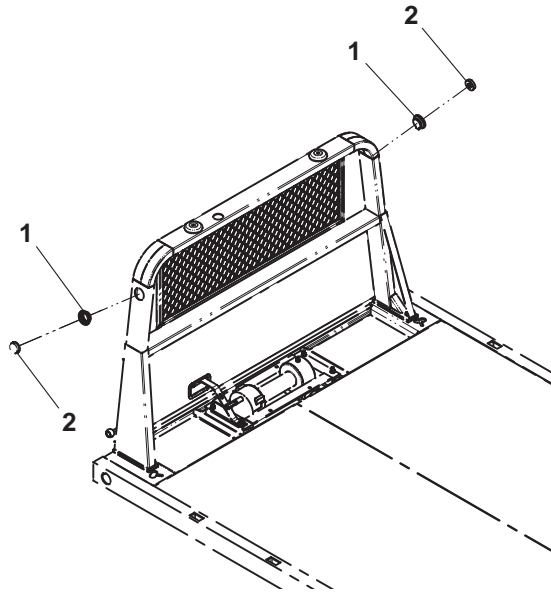

FOR 36" & 40" HEADBOARD

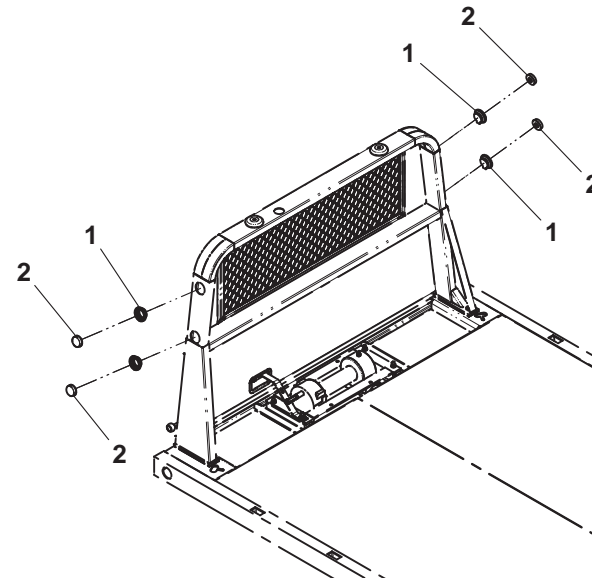

FOR 45", 50" & 57" HEADBOARD

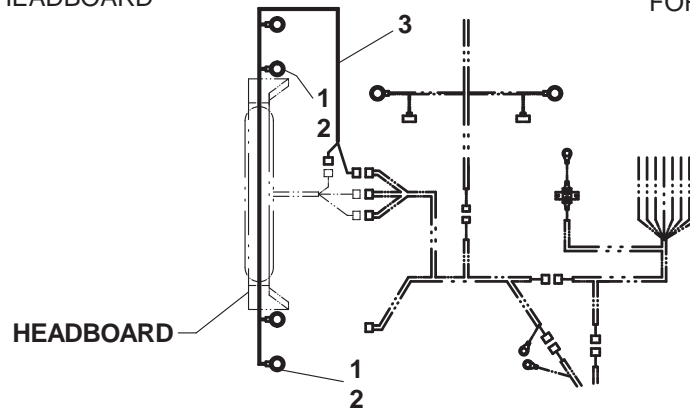

**ELECTRICAL COMPONENTS - OPTIONAL (TAIL LIGHT CONVERTER)**

ITEM	PART NO.	DESCRIPTION	QTY
1	7297000008	Taillight Converter	1
2	4706002990	Plate	1
3	7661000007	Wellnut	4
4	7104100613	Screw, #10-32NF x 0.75"	4
5	7790151253	Screw	2
6	7345001714	Terminal	5
7	4346000005	Heat Shrink Tubing - 1.50"	5
8	7345221902	Terminal	1
9	7345241902	Terminal	1
10	7346000126	Fuse Holder	1
11	7457000017	Fuse - 30 amp	1
12	7345001914	Terminal	1
13	7346000209	Resistor (UD chassis w/ std lights)	1
14	7346000220	Resistor (UD chassis w/ LED lights)	1

# ELECTRICAL COMPONENTS - OPTIONAL (TAIL LIGHT CONVERTER)

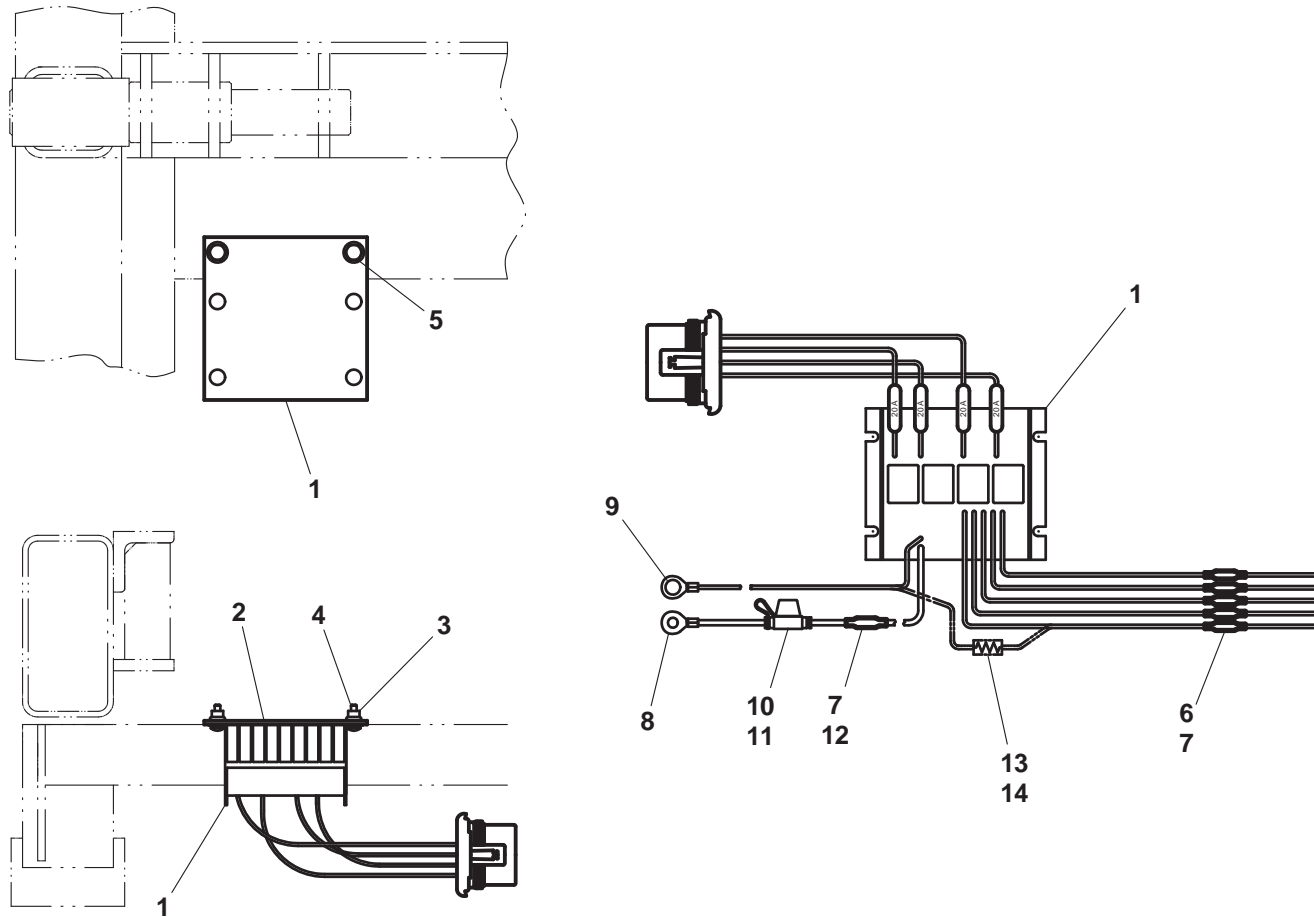

**ADDITIONAL DECK MARKER LIGHTS**

ITEM	PART NO.	DESCRIPTION	QTY
1	7493000009	Grommet	4
2	7590000342	Marker Light - Amber (LED)	4
3	7552000212	Additional Markers Deck Harness	1
4	4017001059	Angle (all steel decks except Rustler)	4
5	7280000013	Clip (all Aluminum Decks & Steel Decks with mini I-Beam x-members)	16
	7280000018	Wire Clip (Steel Decks with channel x-members)	16

# ADDITIONAL DECK MARKER LIGHTS

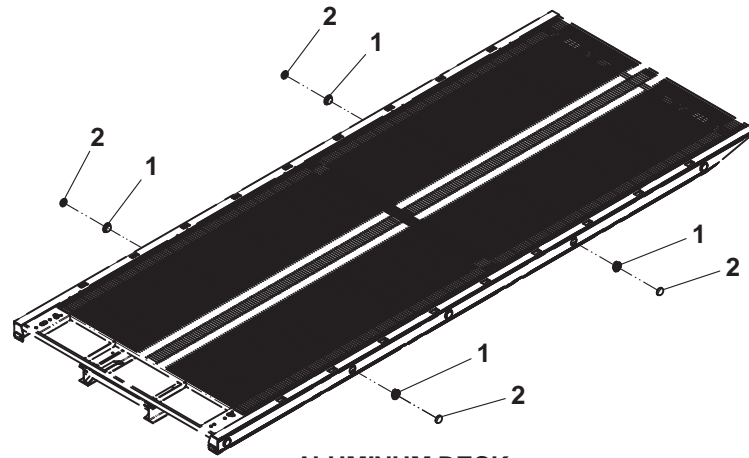

ALUMINUM DECK

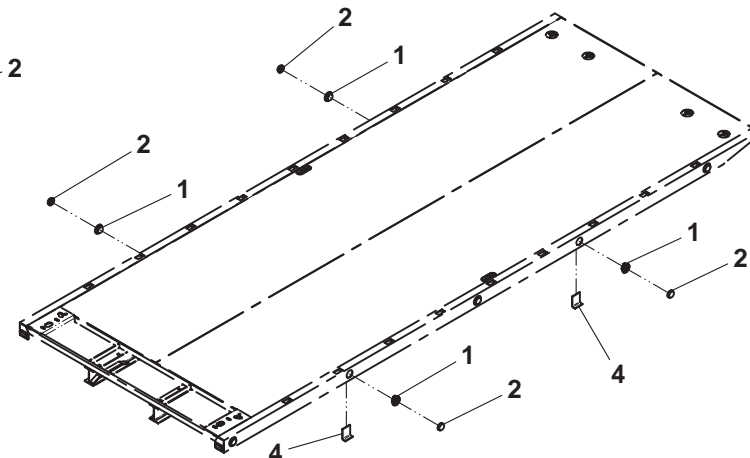

STEEL DECK

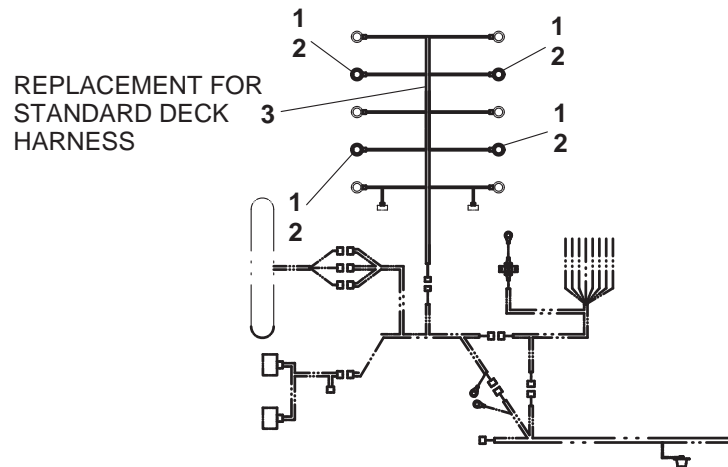

Item #5, Wire Clip, not shown.

**IRL WHEEL LIFT**

ITEM	PART NO.	DESCRIPTION	QTY	ITEM	PART NO.	DESCRIPTION	QTY
1	3170000170	Outer Boom Weld (manual grids) - Std	1	21	3592000036	Link Assembly (manual grids) - Standard	1
	3170000445	Outer Boom Weld (manual grids) - Galv			3592000057	Link Assembly (manual grids) - Galvanized	
	3170000332	Outer Boom Weld (hyd grids)			3592000054	Link Assembly (hyd grids)	
	3170000450	Outer Boom Weld (manual grids - extended reach) - Standard		22	3691000069	Pin Weld (manual grids)	1
	3170000456	Outer Boom Weld (manual grids - extended reach) - Galvanized		23	3691000092	Pin Weld (hyd grids)	
					7082000016^	Bearing	4
2	3911000056	Inner Boom Weld	1	24	7291000010	4-Way Receptacle	1
3	3320000115	Cylinder Assembly	1	25	7796000048	Gasket	1
4	4691000296	Pin	1	26	7114140528	Screw	2
5	4691000268	Pin	1	27	7660142601	Locknut	2
6	7754000006	Retaining Ring	4				
7	7082000020*	Bushing	1				
8	4679000046	Wear Pad	1				
9	4017000739	Angle	2				
10	7118140418	Capscrew, 0.25"-20NC x 0.50"	4				
11	7950100151	Washer, 0.19" ID	4				
12	4679000211	Wear Pad	1				
13	3320000114	Cylinder Assembly (manual grids)	2				
	3320000134	Cylinder Assembly (hyd grids - low frame)					
	3320000114	Cylinder Assembly (hyd grids - high frame)					
14	3691000164	Pin Weld	2				
15	7115160950	Capscrew, 0.38"-16NC x 1.12"	6				
16	7660162601	Locknut, 0.38"-16NC	6				
17	3691000073	Pin Weld	3				
18	3020000097	Arm Weld (manual grids) - Standard	2				
	3020000113	Arme Weld (manual grids) - Galvanized					
	3020000110	Arm Weld (hyd grids - low frame)					
	3020000097	Arm Weld (hyd grids - high frame)					
19	7082000017+	Bearing	4				
20	7082000018+	Bearing	4				

\* included in Inner Boom Weld, P/N 3911000056

+ included in Arm Weld, P/Ns 3020000097 & 3020000110

^ included in Link Weld, P/Ns 3592000036 & 3592000092

# IRL WHEEL LIFT

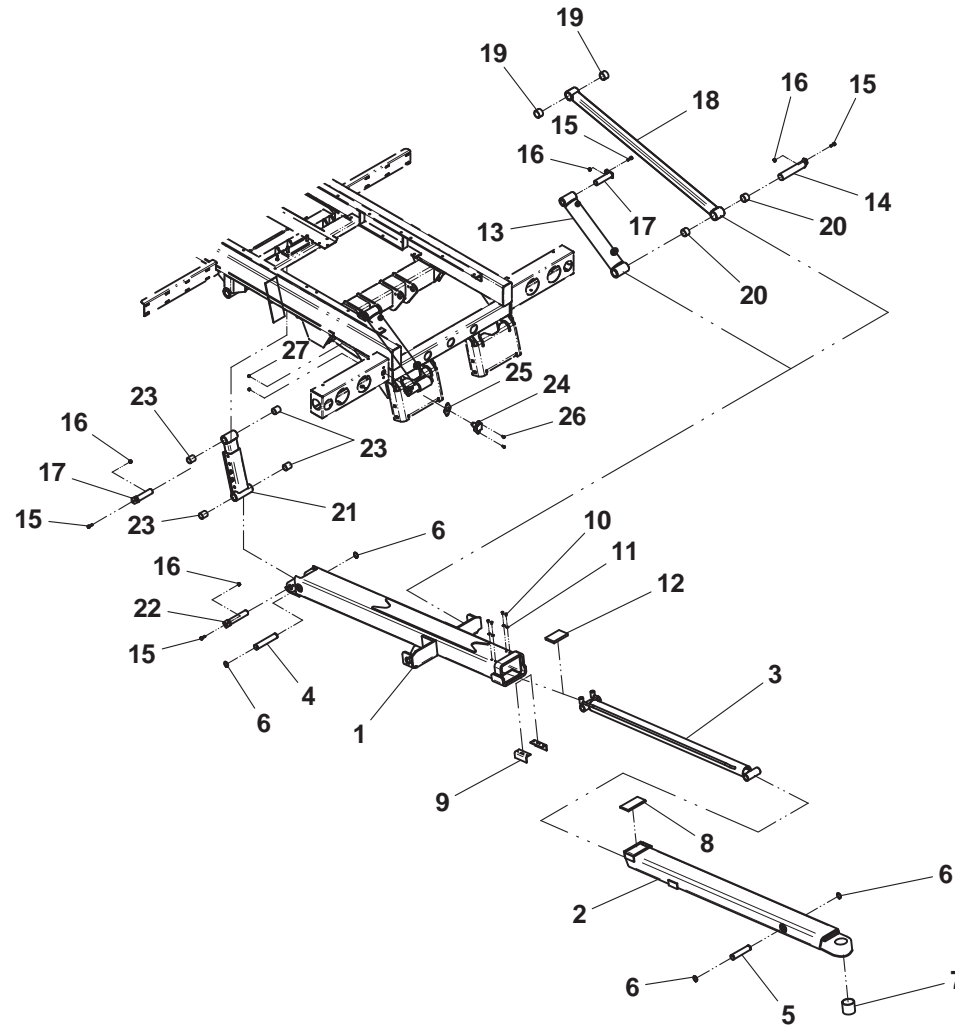

**ZOD WHEEL LIFT**

ITEM	PART NO.	DESCRIPTION	QTY	ITEM	PART NO.	DESCRIPTION	QTY
1	3170000237	Outer Boom Weld (manual grids) - Std	1	23	7291000010	4-Way Receptacle	1
	3170000460	Outer Boom Weld (manual grids) - Galv		24	7796000048	Gasket	1
	3170000428	Outer Boom Weld (hydraulic grids)		25	7114140528	Screw	2
2	3911000056	Inner Boom Weld	1	26	7660142601	Locknut	2
3	3320000115	Cylinder Assembly	1				
4	4691000296	Pin	1				
5	4691000268	Pin	1				
6	7754000006	Retaining Ring	4				
7	7082000020*	Bushing	1				
8	4679000046	Wear Pad	1				
9	4017000739	Angle	2				
10	7118140418	Capscrew, 0.25"-20NC x 0.50"	4				
11	7950100151	Washer, 0.19" ID	4				
12	4679000211	Wear Pad	1				
13	3320000114	Cylinder Assembly (manual grids)	2				
	3320000134	Cylinder Assembly (hyd grids - low frame)					
	3320000114	Cylinder Assembly (hyd grids - high frame)					
14	3691000164	Pin Weld	2				
15	7115160950	Capscrew, 0.38"-16NC x 1.12"	6				
16	7660162601	Locknut, 0.38"-16NC	6				
17	3691000073	Pin Weld	3				
18	3020000097	Arm Weld (manual grids) - Standard	2				
	3020000113	Arm Weld (manual grids) - Galvanized					
	3020000110	Arm Weld (hydraulic grids - low frame)					
	3020000097	Arm Weld (hydraulic grids - high frame)					
19	7082000017+	Bearing	4				
20	7082000018+	Bearing	4				
21	3320000118	Cylinder Assembly (manual grids)	1				
	3320000135	Cylinder Assembly (hyd grids - low frame)					
	3320000157	Cylinder Assembly (hyd grids - high frame)					
22	3691000069	Pin Weld (manual grids)	1				
	3691000092	Pin Weld (hydraulic grids)					

\* included in Inner Boom Weld, P/N 3911000056

+ included in Arm Welds, P/Ns 3020000097 & 3020000110



# ZOD WHEEL LIFT

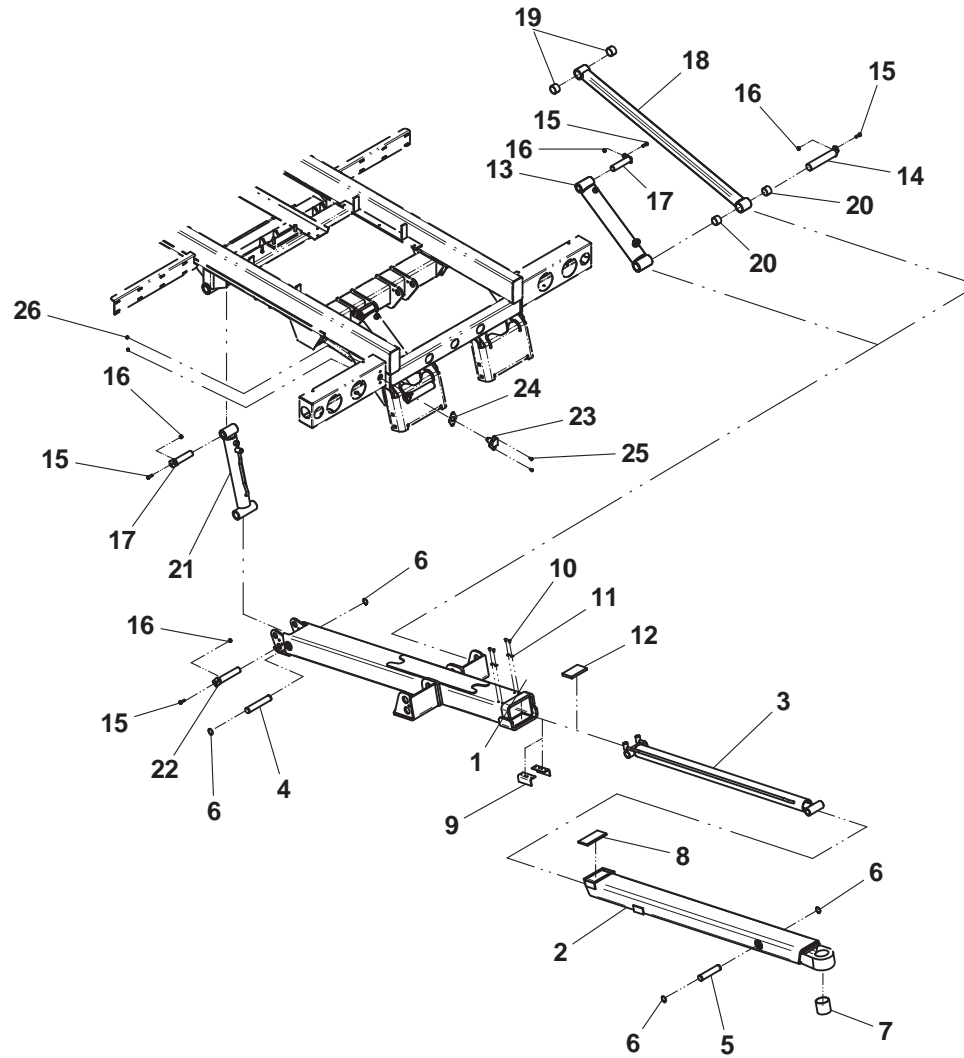

**MANUAL L-ARM WHEEL LIFT GRID**

ITEM	PART NO.	DESCRIPTION	QTY
1	3913000093	Pivot Tube Weld (3,000 lb IRL wheel lift w/ ball plate)	1
	3913000096	Pivot Tube Weld (3,000 lb ZOD wheel lift w/ ball plate)	
	3913000098	Pivot Tube Weld (3,000 lb IRL wheel lift w/ 2" Reese Rcvr)	
	3913000099	Pivot Tube Weld (3,000 lb ZOD wheel lift w/ 2" Reese Rcvr)	
2	3484000035	Grid Weld - LH	1
3	3484000034	Grid Weld - RH	1
4	4691000447	Pivot Pin	1
5	4949000047	Washer	2
6	7754000024	Retaining Ring	1
7	3551000036	T-Handle	2
8	3020000072	L-Arm Weld - Standard	2
	3020000114	L-Arm Weld - Galvanized	
9	7701000062	Plug	2
10	3551000011	Cam Lock Assembly	2
11	7440030000	Grease Fitting	2
12	7330000419	Reflective Tape	2
13	7330000417	Reflective Tape - LH	1
14	7330000418	Reflective Tape - RH	1

# MANUAL L-ARM WHEEL LIFT GRID

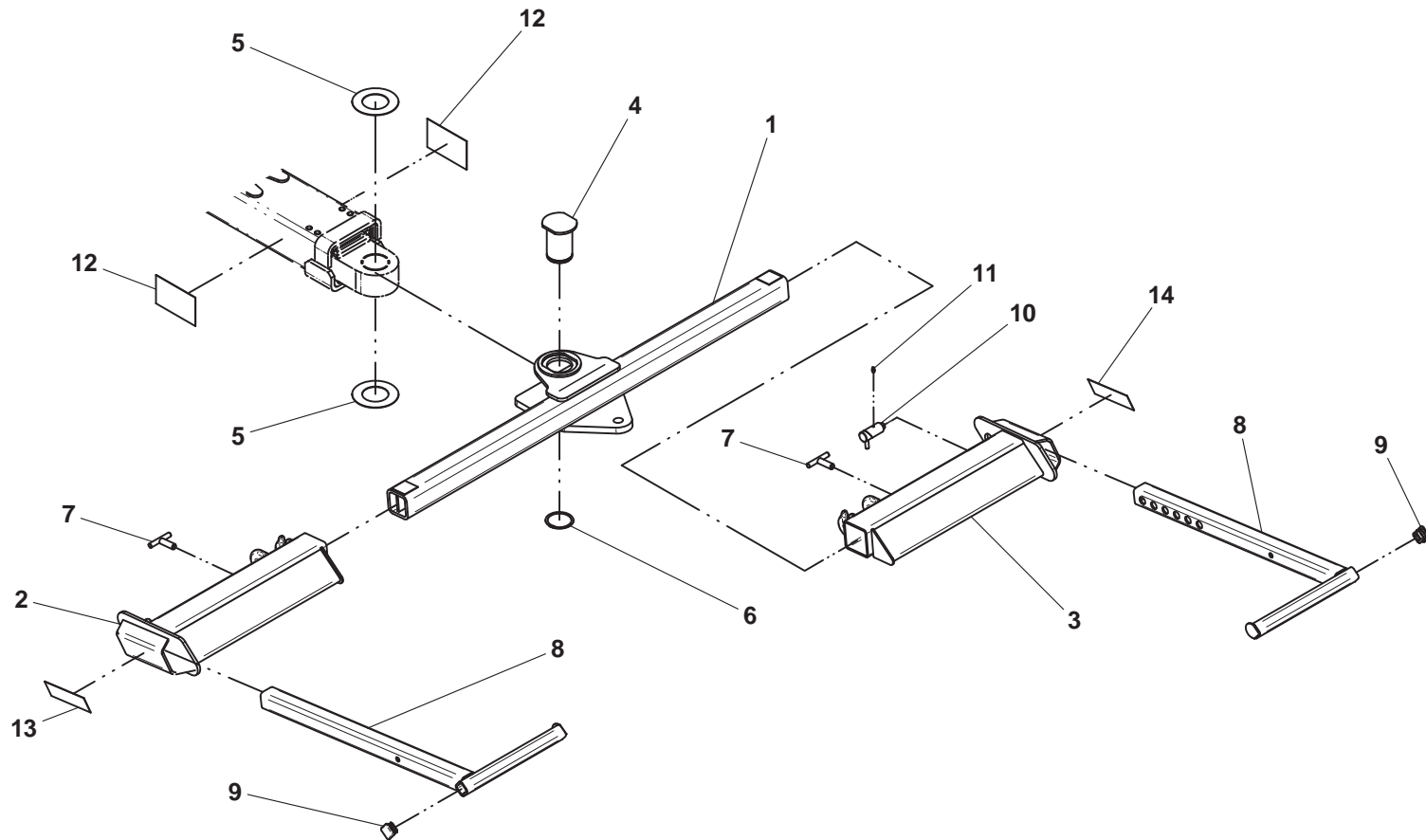

Pivot tube weld with IRL ball hitch mounting plate shown

**MANUAL T37 PIVOTING WHEEL LIFT GRID**

ITEM	PART NO.	DESCRIPTION	QTY	ITEM	PART NO.	DESCRIPTION	QTY
1	3913000093	Pivot Tube Weld (3,000 lb IRL wheel lift w/ ball plate)	1	25	7330000432	Reflective tape	1
	3913000096	Pivot Tube Weld (3,000 lb ZOD wheel lift w/ ball plate)		26	7950200000	Lockwasher, 0.63" ID	2
	3913000098	Pivot Tube Weld (3,000 lb IRL wheel lift w/ 2" Reese Rcvr)					
	3913000099	Pivot Tube Weld (3,000 lb ZOD wheel lift w/ 2" Reese Rcvr)					
2	3484000051*	Grid Weld - LH	1				
3	3484000050+	Grid Weld - RH	1				
4	4259000002*	Pivot Casting, LH	1				
5	4259000001+	Pivot Casting, RH	1				
6	4691000354*+	Pin	2				
7	4691000357*+	Pin	2				
8	7754000037*+	Retaining Ring	2				
9	3551000036	T-Handle	2				
10	4691000186*+	Pin	2				
11	7843000006*+	Spring	2				
12	4763000184*+	Rod	2				
13	4254000005*+	Cap	2				
14	7786000006*+	Screw	2				
15	7843000016*+	Spring	2				
16	4691000183*+	Pin	2				
17	4691000447	Pivot Pin	1				
18	4949000047	Washer	2				
19	7754000024	Retaining Ring	1				
20	7440030000	Grease Fitting	6				
21	3020000029	L-Arm Weld - LH	1				
22	3020000030	L-Arm Weld - RH	1				
23	7330000419	Reflective Tape	2				
24	7330000420	Reflective Tape	1				

\* also available in Grid Assembly, LH, P/N 3484000053  
 + also available in Grid Assembly, RH, P/N 3484000052

# MANUAL T37 PIVOTING WHEEL LIFT GRID

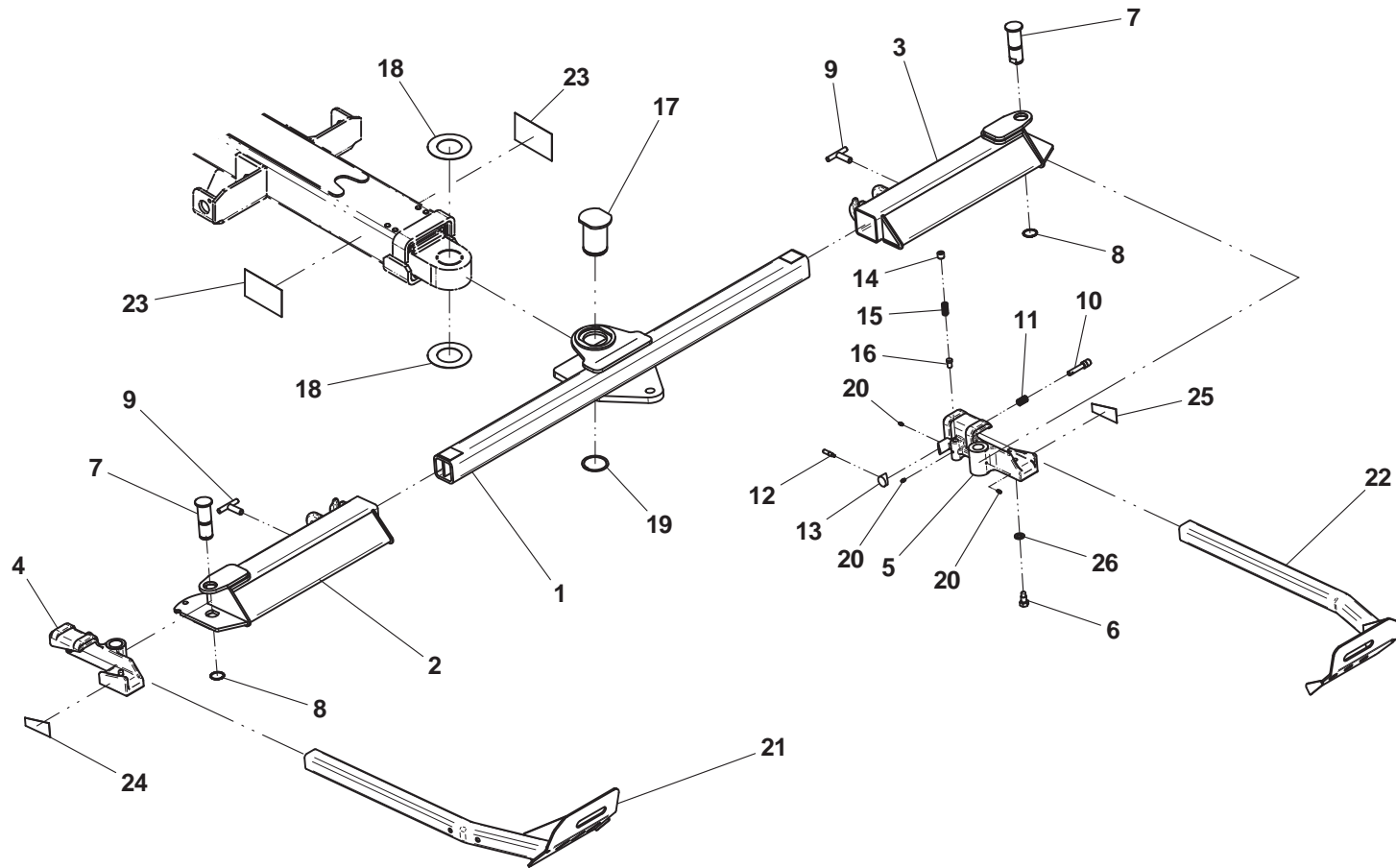

Pivot tube weld with IRL ball hitch mounting plate shown

**HYDRAULIC WHEEL LIFT GRID**

ITEM	PART NO.	DESCRIPTION	QTY	ITEM	PART NO.	DESCRIPTION	QTY
1	4691000482	Pivot Pin	1	32	4679000268	Pad	1
2	4949000047	Washer	2	33	7118161026	Capscrew, 0.38"-16NC x 1.25"	2
3	7754000024	Retaining Ring	1	34	4314000076*	Coverplate	2
4	3484000074*	Grid Crossbar Weld	1	35	7115140518*	Capscrew, 0.25"-20NC x 0.62"	4
5	7320000064*	Cylinder Assembly	2	36	7785140400*	Set Screw	2
6	3691000229*	Pin Weld	4	37	4619000013*	Manifold	1
7	7115151023*	Capscrew, 0.31"-18NC x 1.25"	6	38	7445040443*	Adapter	4
8	7660152601*	Locknut, 0.31"-18NC	6	39	7912000184*	Tube Assembly	4
9	4691000497*	Pin	2	40	7274000086*	Clamp	4
10	3592000052*	Link Weld	2	41	7274000039*	Cover	2
11	3592000051*	Link Weld	2	42	7115151250*	Capscrew, 0.31"-18NC x 1.50"	2
12	4706003497*	Plate	2	40	4314000117	Cover Plate, LH	1
13	7754000022*	Retaining Ring	4	41	4314000118	Cover Plate, RH	1
14	7330000419	Reflective Tape	2	42	7790151253	Screw, 0.31"-18NC x 0.75"	8
15	3691000230	Pin Weld	2	43	7732000002	Spring Reel	2
16	3020000115*	Arm Weld, LH	1	44	4831000109	Spacer	2
17	3020000111*	Arm Weld, RH	1	45	7719000004	Roller	2
18	7754000087	Retaining Ring	4	46	4706003501	Plate	2
19	7843000043	Extension Spring	2	47	7691000040	Clevis Pin	2
20	7248000115	Cable Assembly	2	48	7691000042	Cotter Pin	2
21	7690141600	Pin	2	49	3619000001	Manifold Weld	2
22	7690021210	Cotter Pin	2	50	7115140850	Capscrew, 0.25"-20NC x 1.00"	4
23	4831000112	Spacer	4	51	7950140153	Flatwasher, 0.25" ID	8
24	7719000005	Pulley	2	52	7660142604	Locknut, 0.25"-20NC	8
25	7690144005	Clevis Pin	2	53	7445040445	Elbow	4
26	3691000222	Pin Weld	2	54	7912000237	Tube	2
27	7115150423	Capscrew, 0.31"-18NC x 0.50"	2	55	7274000073	Hose Clamp	4
28	4949000072	Washer	4	56	7785140870*	Set Screw	2
29	7754000006	Retaining Ring	2	57	4691000527	Pin	2
30	3020000112	Arm Weld	2	58	7082000026^#	Bearing	10
31	8411080091	Wheel Spacer	2	59	7082000027+>	Bearing	6

\* also available in Grid Crossbar Assembly, P/N 3484000075

^ also quantity of 8 available in Link Welds, P/N 3592000052

+ also quantity of 2 each available in Arm Weld P/N 3020000115 & P/N 3020000111

# also quantity of 1 each available in Arm Weld P/N 3020000115 & 3020000111

> also quantity of 2 available in Arm Welds P/N 3020000112

# HYDRAULIC WHEEL LIFT GRID

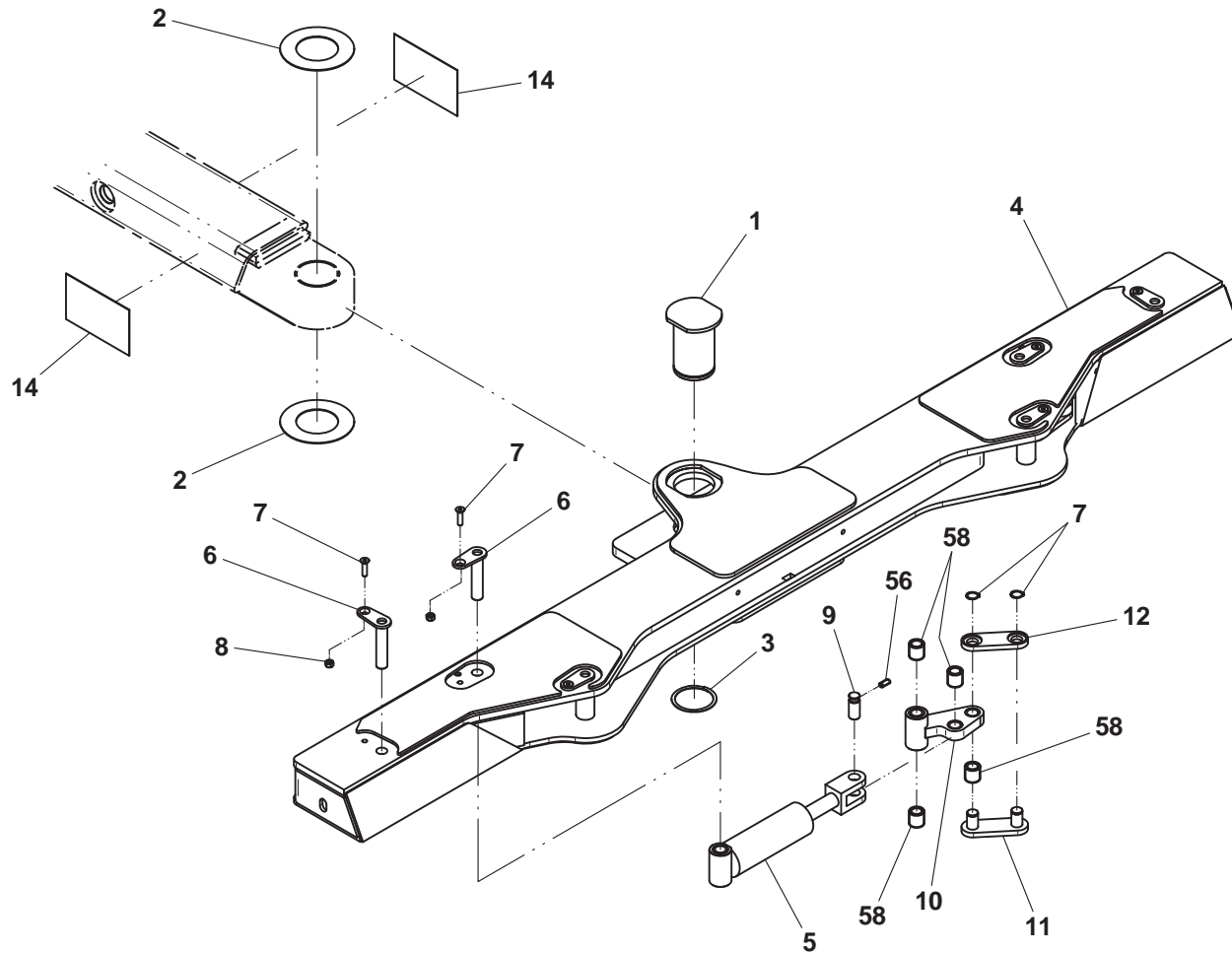

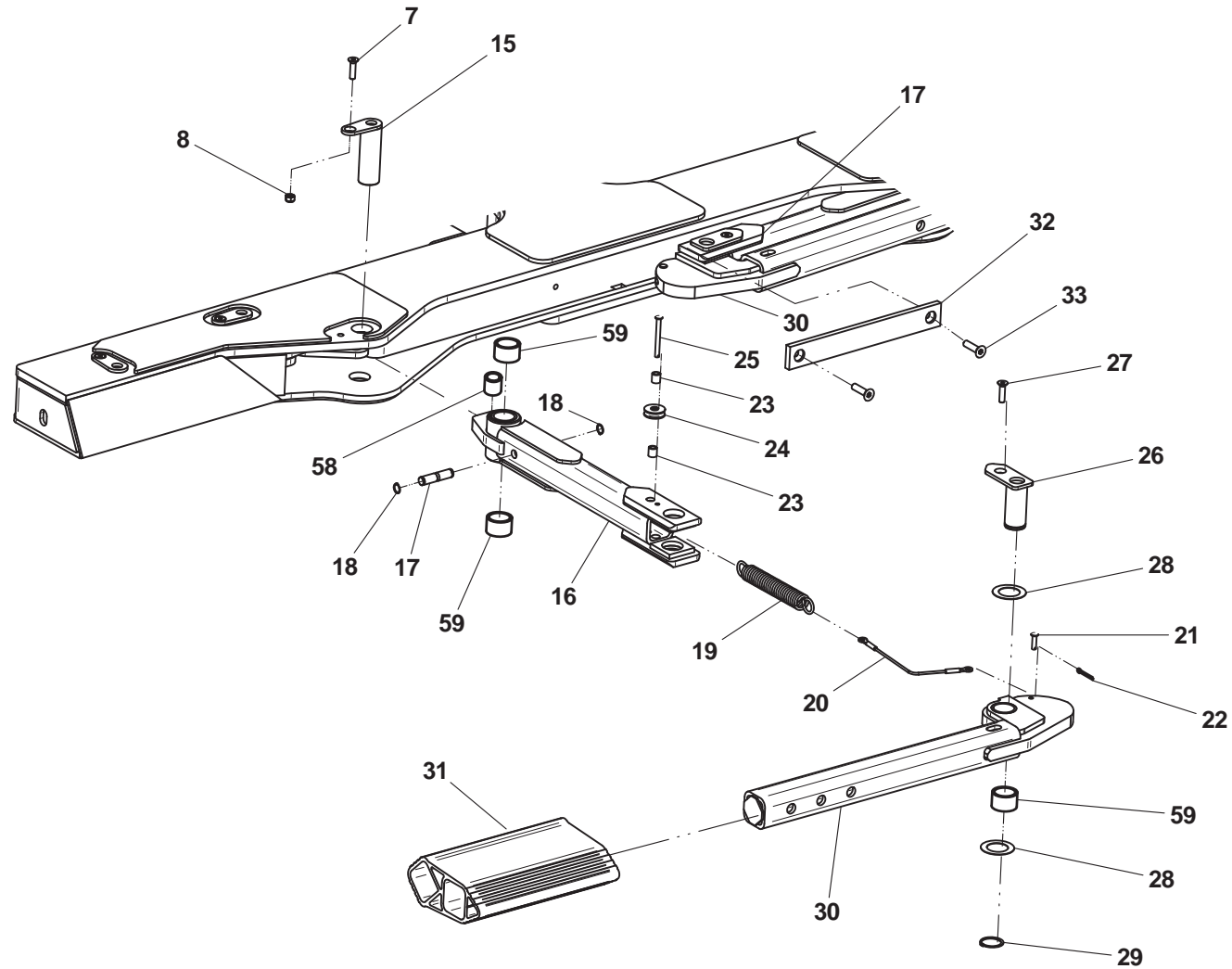
**HYDRAULIC WHEEL LIFT GRID**



# HYDRAULIC WHEEL LIFT GRID

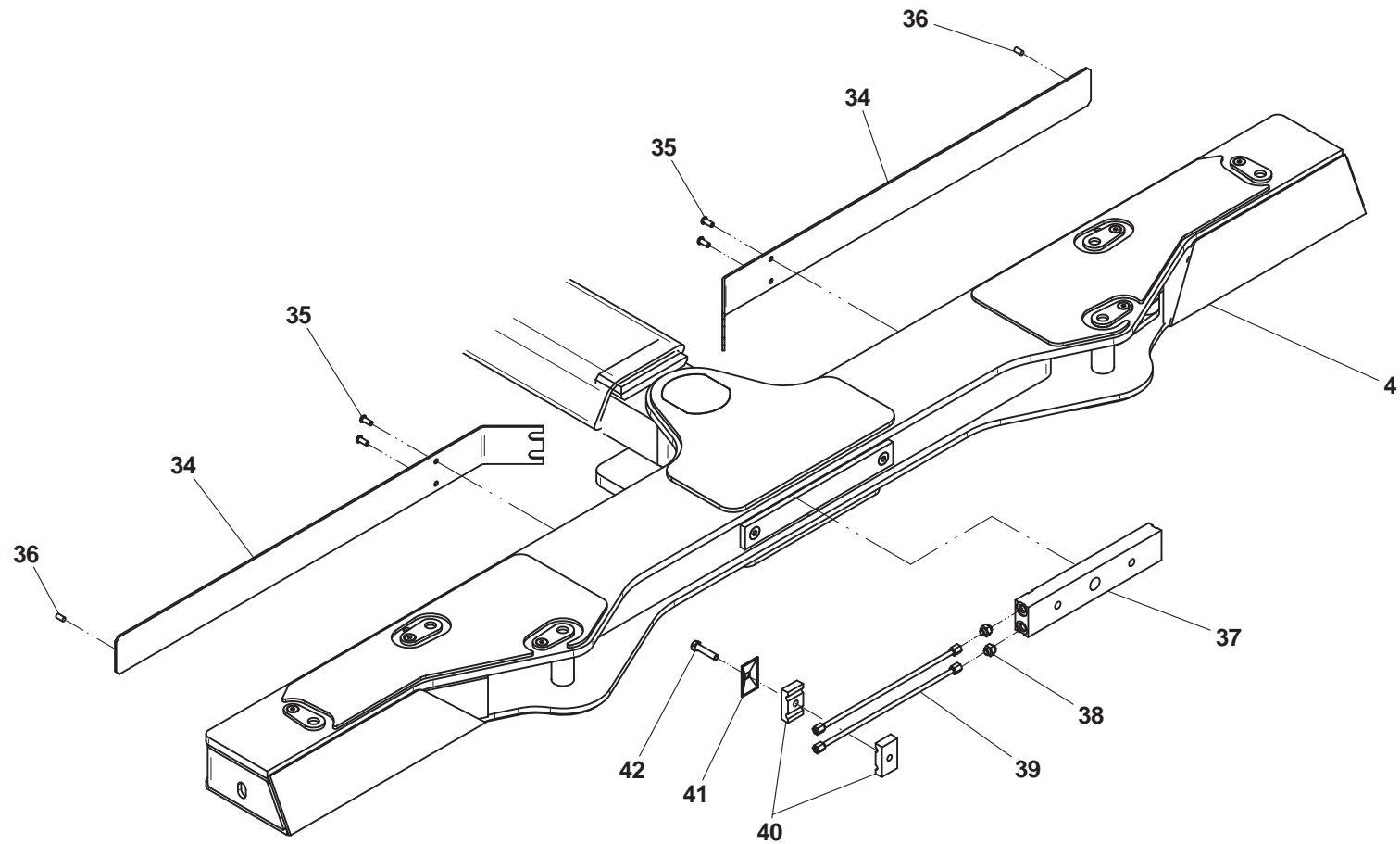

## HYDRAULIC WHEEL LIFT GRID

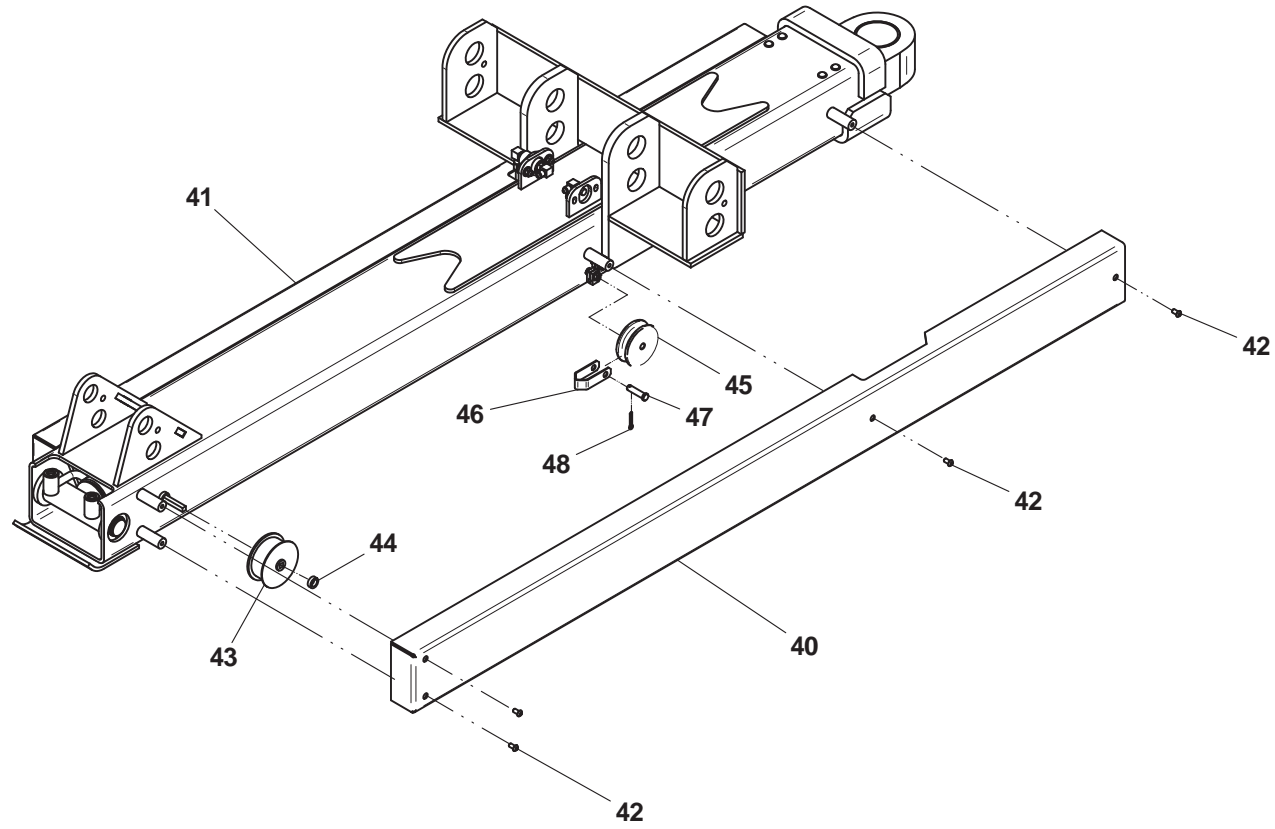

# HYDRAULIC WHEEL LIFT GRID

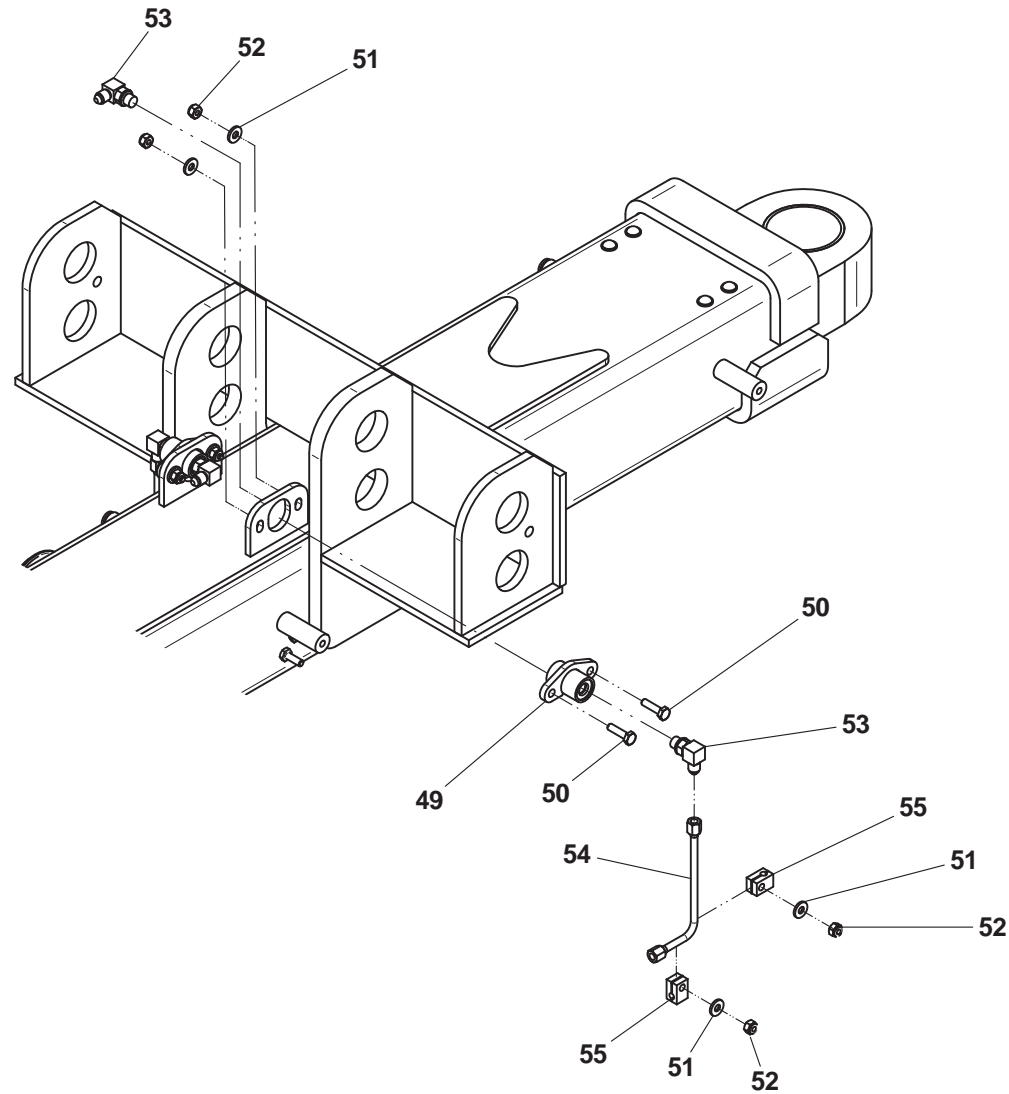

**HYDRAULIC REAR DOCK STABILIZER**

ITEM	PART NO.	DESCRIPTION	QTY
1	3849000021	Stabilizer Weld	1
2	3320000119	Cylinder Assembly	2
3	3691000165	Pin Weld	2
4	3691000073	Pin Weld	2
5	7115160950	Capscrew, 0.38"-16NC x 1.12"	4
6	7660162601	Locknut, 0.38"-16NC	4
7	7082000017*	Bearing	4

\* included in Stabilizer Weld, P/N 3849000021

# HYDRAULIC REAR DOCK STABILIZER

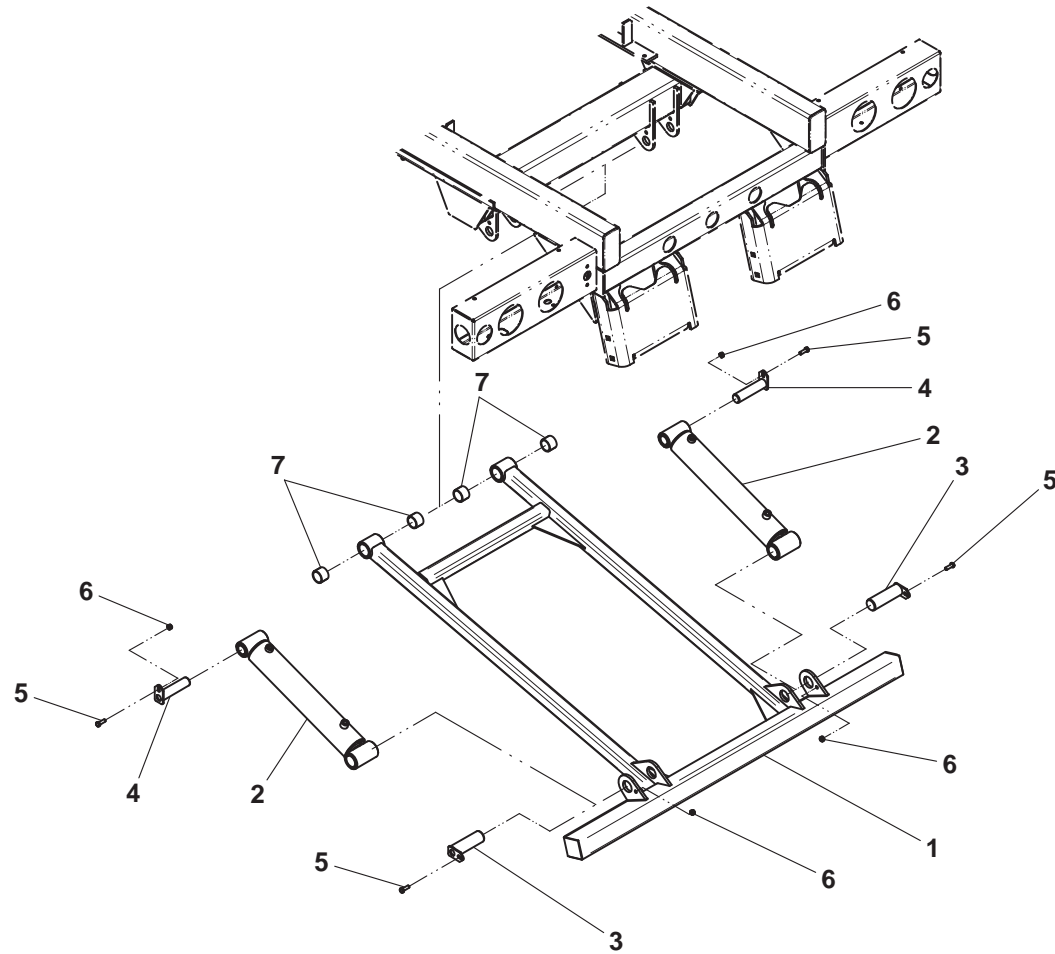

**HYDRAULIC REAR DOCK STABILIZER WITH REESE HITCH RECEIVER**

ITEM	PART NO.	DESCRIPTION	QTY
1	3849000023	Stabilizer Weld (with 2.00" Reese Hitch Receiver)	1
	3849000041	Stabilizer Weld (with 2.50" Reese Hitch Receiver)	
2	3320000114	Cylinder Assembly	2
3	3691000165	Pin Weld	2
4	3691000073	Pin Weld	2
5	7115160950	Capscrew, 0.38"-16NC x 1.12"	4
6	7660162601	Locknut, 0.38"-16NC	4
7	7082000017*^	Bearing	4
8	7291000010	4-Way Receptacle	1
9	7796000048	Gasket	1
10	7114140528	Screw, 0.25"-20NC x .63"	2
11	7660142601	Locknut, 0.25"-20NC	2

\* included in Stabilizer Weld, P/N 3849000023

^ included in Stabilizer Weld, P/N 3849000041

# HYDRAULIC REAR DOCK STABILIZER WITH REESE HITCH RECEIVER

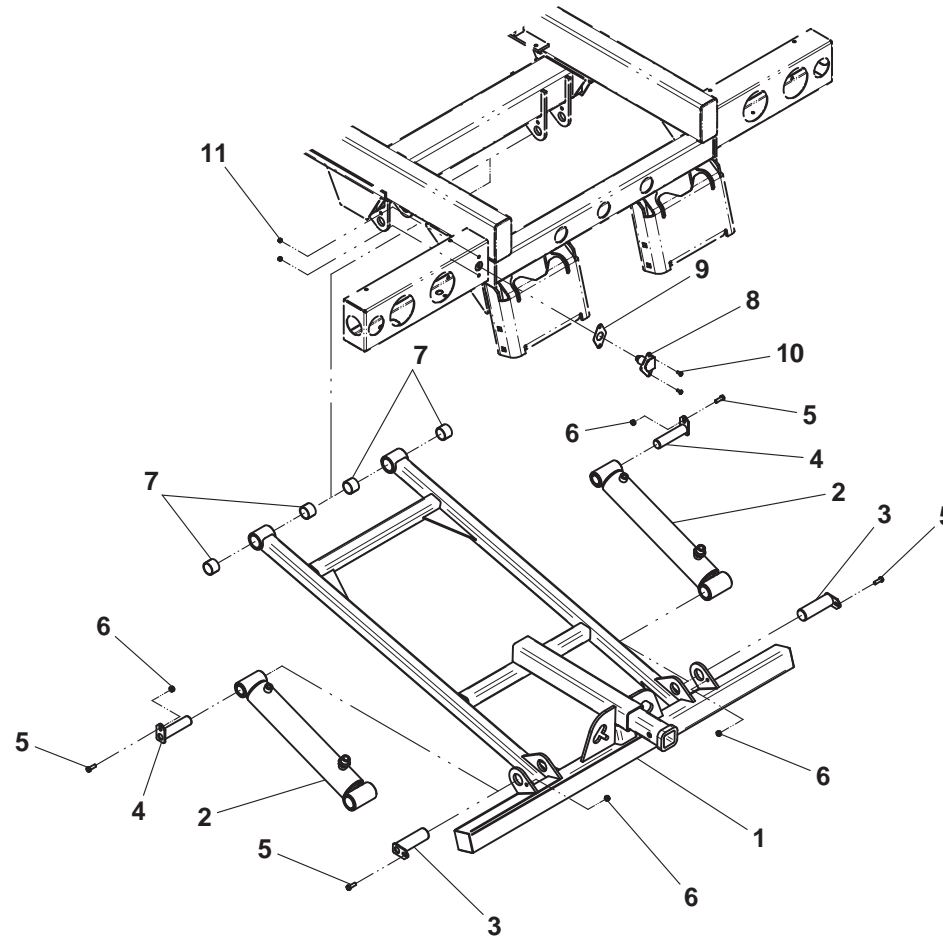

**HYDRAULIC REAR DOCK STABILIZER WITH MANUAL EXTEND PINTLE HITCH MOUNTING PLATE**

ITEM	PART NO.	DESCRIPTION	QTY
1	3849000022	Stabilizer Weld w/ Manual Pintle Plate	1
2	3320000114	Cylinder Assembly	2
3	3691000165	Pin Weld	2
4	3691000073	Pin Weld	2
5	7115160950	Capscrew, 0.38"-16NC x 1.12"	4
6	7660162601	Locknut, 0.38"-16NC	4
7	3170000203	Inner Boom Weld	1
8	3691000064	Pin Weld	1
9	7691000001	Hair Pin	1
10	7082000017*	Bearing	4
11	7291000010	4-Way Receptacle	1
12	7796000048	Gasket	1
13	7114140528	Screw, 0.25"-20NC x 0.63"	2
14	7660142601	Locknut, 0.25"-20NC	2

\* included in Stabilizer Weld, P/N 3849000022



# HYDRAULIC REAR DOCK STABILIZER WITH MANUAL EXTEND PINTLE HITCH MOUNTING PLATE

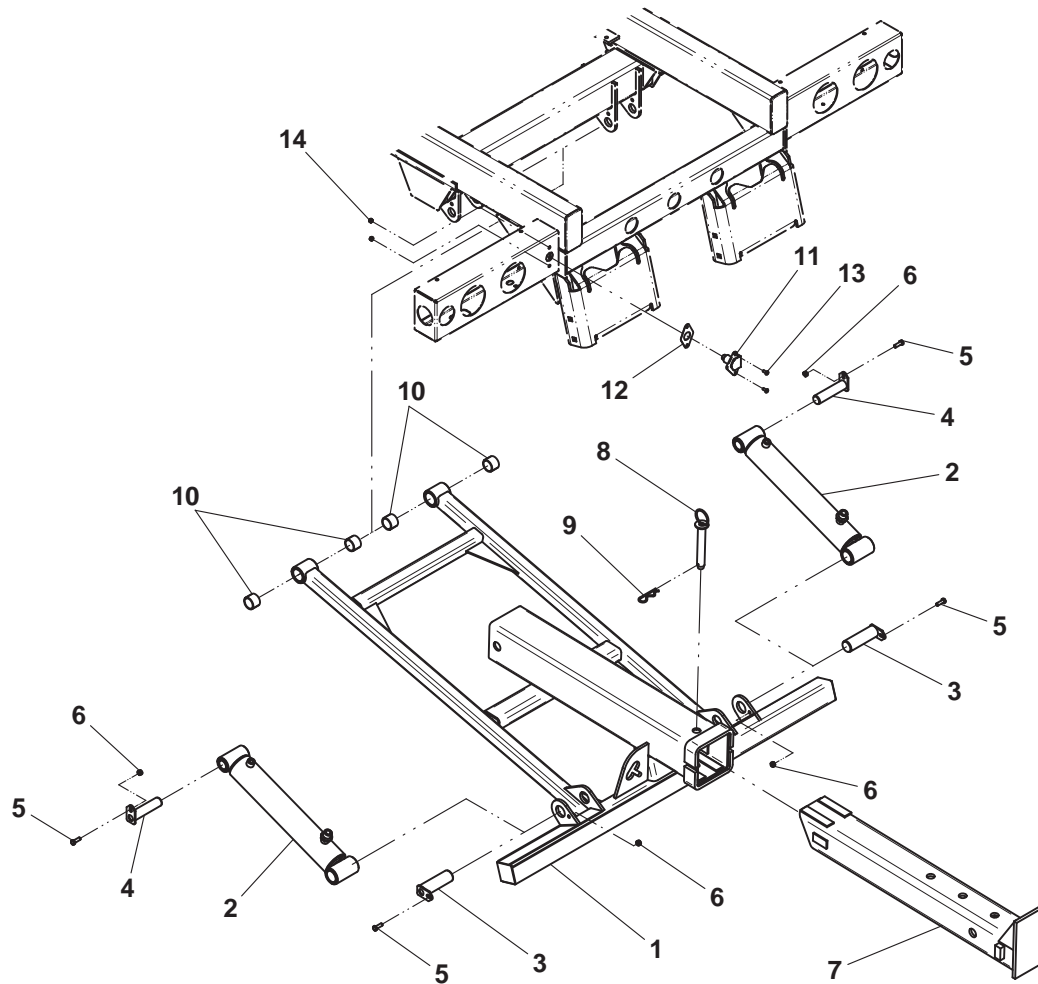

**HYDRAULIC REAR DOCK STABILIZER WITH HYDRAULIC EXTEND PINTLE HITCH MOUNTING PLATE**

ITEM	PART NO.	DESCRIPTION	QTY
1	3849000022	Stabilizer Weld w/ Pintle Hitch Plate	1
2	3320000114	Cylinder Assembly	2
3	3691000165	Pin Weld	2
4	3691000073	Pin Weld	2
5	7115160950	Capscrew, 0.38"-16NC x 1.12"	4
6	7660162601	Locknut, 0.38"-16NC	4
7	3170000203	Inner Boom Weld	1
8	3691000064	Pin Weld	1
9	7691000001	Hair Pin	1
10	3320000117	Cylinder Assembly	1
11	4691000430	Pin	1
12	4691000429	Pin	1
13	7754000006	Retaining Ring	1
14	7082000017*	Bearing	4
15	7291000010	4-Way Receptacle	1
16	7796000048	Gasket	1
17	7114140528	Screw, 0.25"-20NC x 0.63"	2
18	7660142601	Locknut, 0.25"-20NC	2

\* included in Stabilizer Weld, P/N 3849000022

# HYDRAULIC REAR DOCK STABILIZER WITH HYDRAULIC EXTEND PINTLE HITCH MOUNTING PLATE

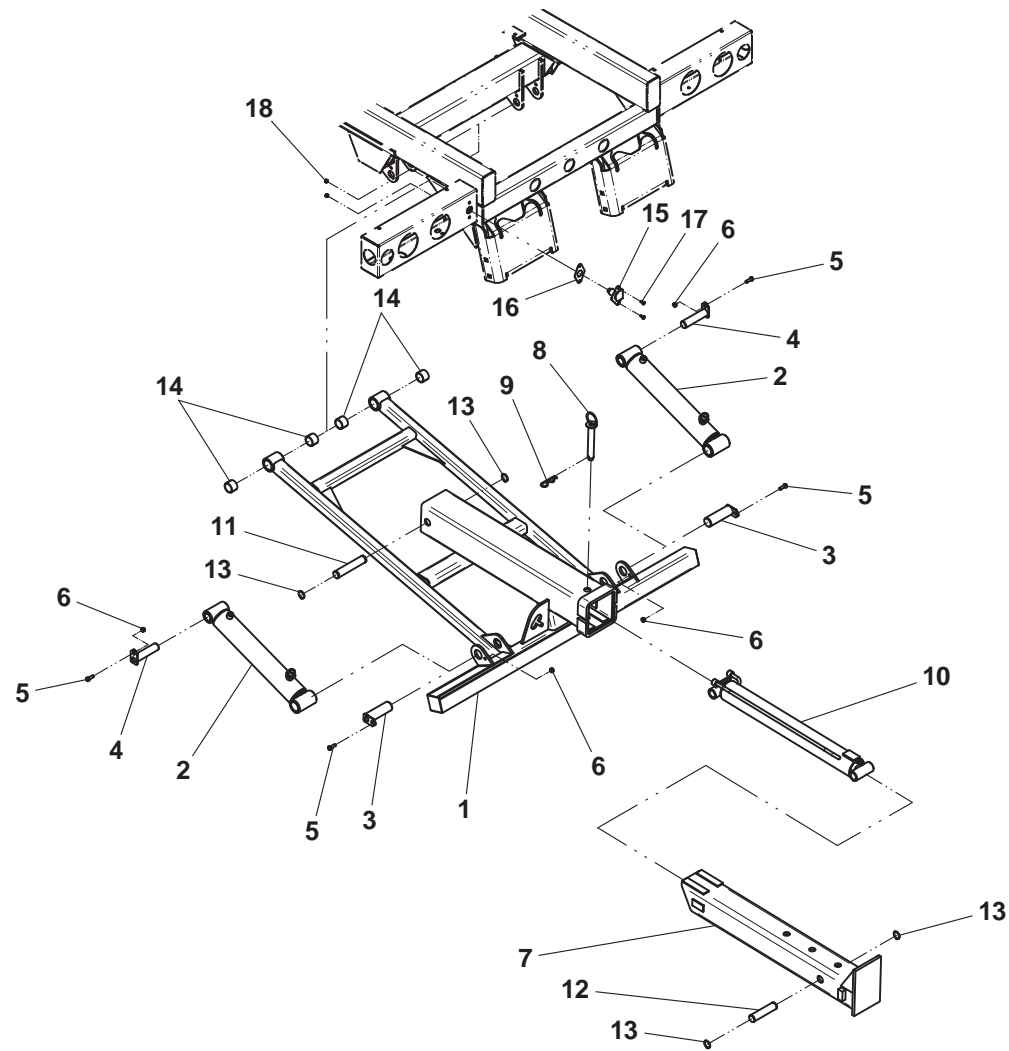

**BALL HITCH MOUNTING PLATE - IRL**

ITEM	PART NO.	DESCRIPTION	QTY
1	3170000275	Outer Boom Weld	1
2	3911000062	Inner Boom Weld	1
3	3320000116	Cylinder Assembly	1
4	4691000430	Pin	1
5	4691000429	Pin	1
6	7754000006	Retaining Ring	4
7	3691000064	Pin Weld	1
8	7691000001	Hair Pin	1
9	3320000114	Cylinder Assembly	2
10	3691000164	Pin Weld	2
11	7115160950	Capscrew, 0.38"-16NC x 1.12"	5
12	7660162601	Locknut, 0.38"-16NC	5
13	3691000073	Pin Weld	3
14	3020000097	Arm Weld	2
15	7082000017*	Bushing	4
16	7082000018*	Bushing	4
17	7082000016+	Bushing	2
18	7291000010	4-Way Receptacle	1
19	7796000048	Gasket	1
20	7114140528	Screw, 0.25"-20NC x 0.63"	2
21	7660142601	Locknut, 0.25"-20NC	2
22	4330000002	Reflective Tape	2

\* included in Arm Weld, P/N 3020000097

+ included in Outer Boom Weld, P/N 3170000275

# BALL HITCH MOUNTING PLATE - IRL

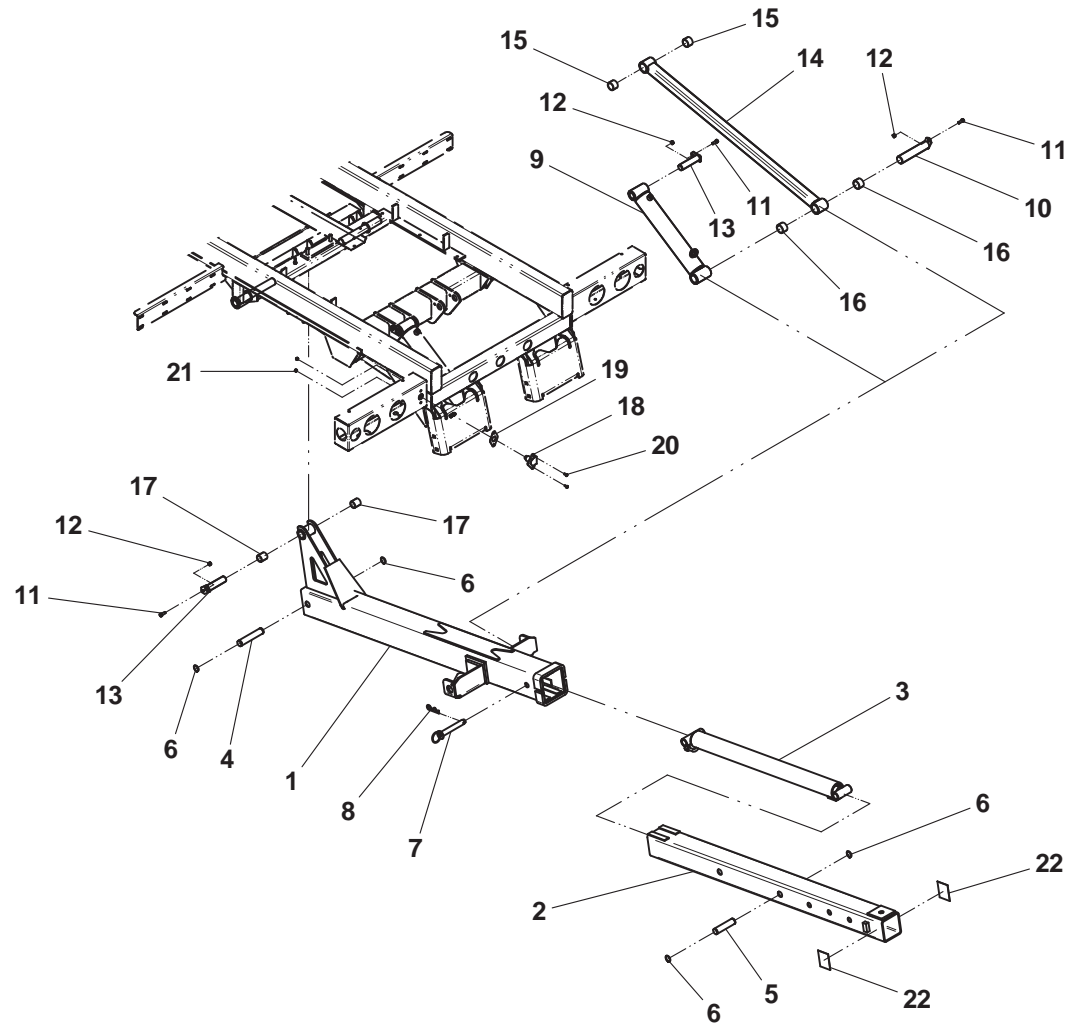

**BALL HITCH MOUNTING PLATE - HYDRAULIC EXTEND**

ITEM	PART NO.	DESCRIPTION	QTY
1	3170000276	Outer Boom Weld	1
2	3911000062	Inner Boom Weld	1
3	3320000116	Cylinder Assembly	1
4	4691000430	Pin	1
5	4691000429	Pin	1
6	7754000006	Retaining Ring	4
7	3691000073	Pin Weld	1
8	3691000064	Pin Weld	1
9	7115160950	Capscrew, 0.38"-16NC x 1.12"	1
10	7660162601	Locknut, 0.38"-16NC	1
11	3691000097	Pin Weld	1
12	7691000001	Hair Pin	2
13	7082000016*	Bushing	2
14	7291000010	4-Way Receptacle	1
15	7796000048	Gasket	1
16	7114140528	Screw, 0.25"-20NC x 0.63"	2
17	7660142601	Locknut, 0.25"-20NC	2
18	4330000002	Reflective Tape	2

\* included in Outer Boom Weld, P/N 3170000276

# BALL HITCH MOUNTING PLATE - HYDRAULIC EXTEND

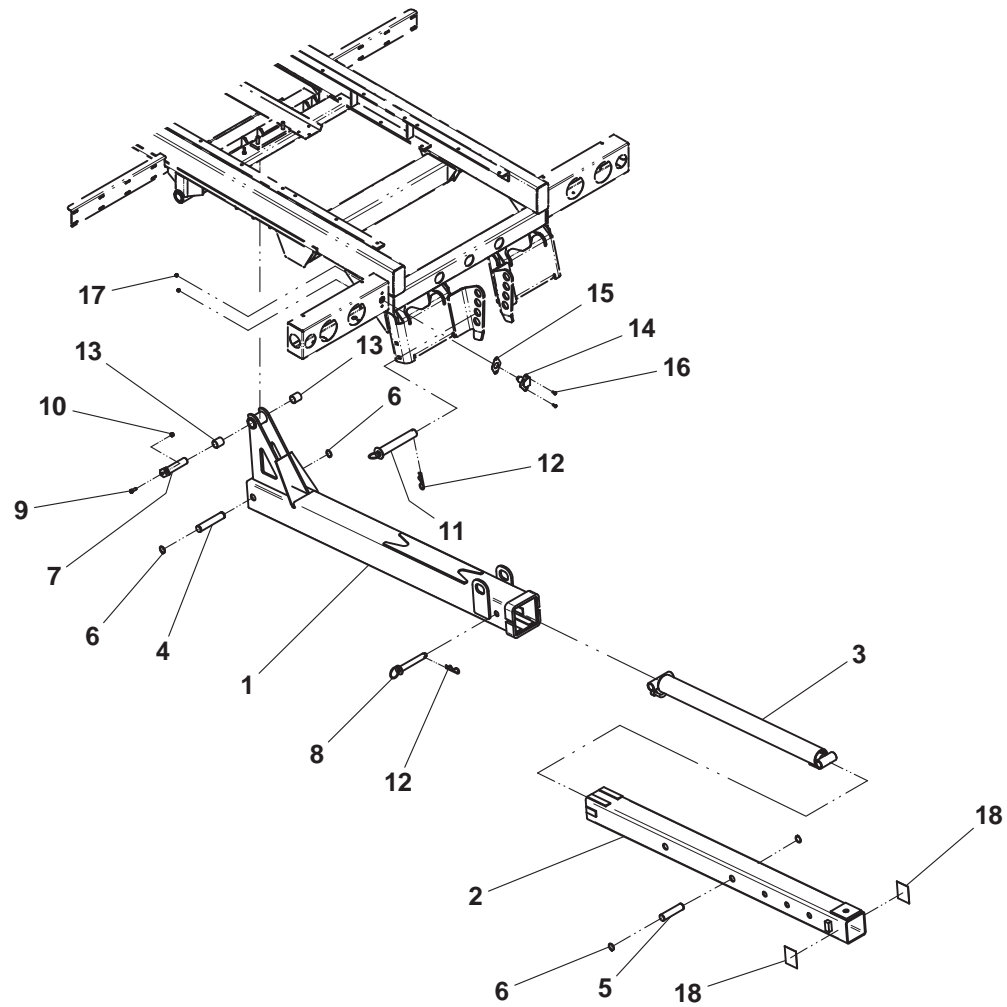

**BALL HITCH MOUNTING PLATE - MANUAL EXTEND**

ITEM	PART NO.	DESCRIPTION	QTY
1	3170000276	Outer Boom Weld	1
2	3911000062	Inner Boom Weld	1
3	3691000064	Pin Weld	1
4	7691000001	Hair Pin	2
5	3691000073	Pin Weld	1
6	7115160950	Capscrew, 0.38"-16NC x 1.12"	1
7	7660162601	Locknut, 0.38"-16NC	1
8	3691000097	Pin Weld	1
9	7082000016*	Bushing	2
10	7291000010	4-Way Receptacle	1
11	7796000048	Gasket	1
12	7114140528	Screw, 0.25"-20NC x 0.63"	2
13	7660142601	Locknut, 0.25"-20NC	2
14	4330000002	Reflective Tape	2

\* included in Outer Boom Weld, P/N 3170000276



# BALL HITCH MOUNTING PLATE - MANUAL EXTEND

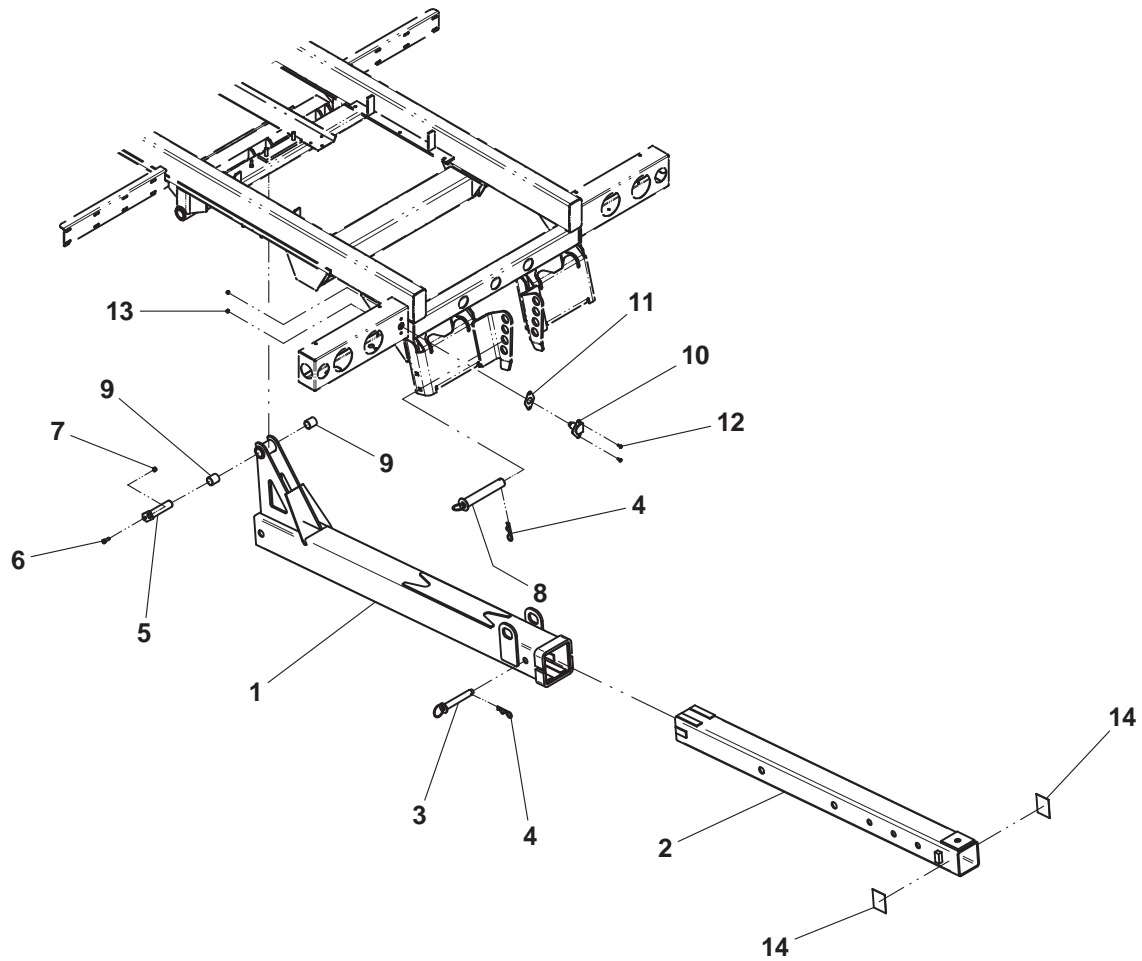

**PINTLE HITCH MOUNTING PLATE - IRL**

ITEM	PART NO.	DESCRIPTION	QTY
1	3170000275	Outer Boom Weld	1
2	3170000208	Inner Boom Weld	1
3	3320000116	Cylinder Assembly	1
4	4691000430	Pin	1
5	4691000429	Pin	1
6	7754000006	Retaining Ring	4
7	3691000064	Pin Weld	1
8	7691000001	Hair Pin	1
9	3320000114	Cylinder Assembly	1
10	3691000164	Pin Weld	2
11	7115160950	Capscrew, 0.38"-16NC x 1.12"	5
12	7660162601	Locknut, 0.38"-16NC	5
13	3691000073	Pin Weld	3
14	3020000097	Arm Weld	2
15	7082000017*	Bushing	4
16	7082000018*	Bushing	4
17	7082000016+	Bushing	2
18	7291000010	4-Way Receptacle	1
19	7796000048	Gasket	1
20	7114140528	Screw, 0.25"-20NC x 0.63"	2
21	7660142601	Locknut, 0.25"-20NC	2
22	4330000002	Reflective Tape	1
23	4330000645	Reflective Tape, LH	1
24	4330000646	Reflective Tape, RH	1

\* included in Arm Weld, P/N 3020000097

+ included in Outer Boom Weld, P/N 3170000275

# PINTLE HITCH MOUNTING PLATE - IRL

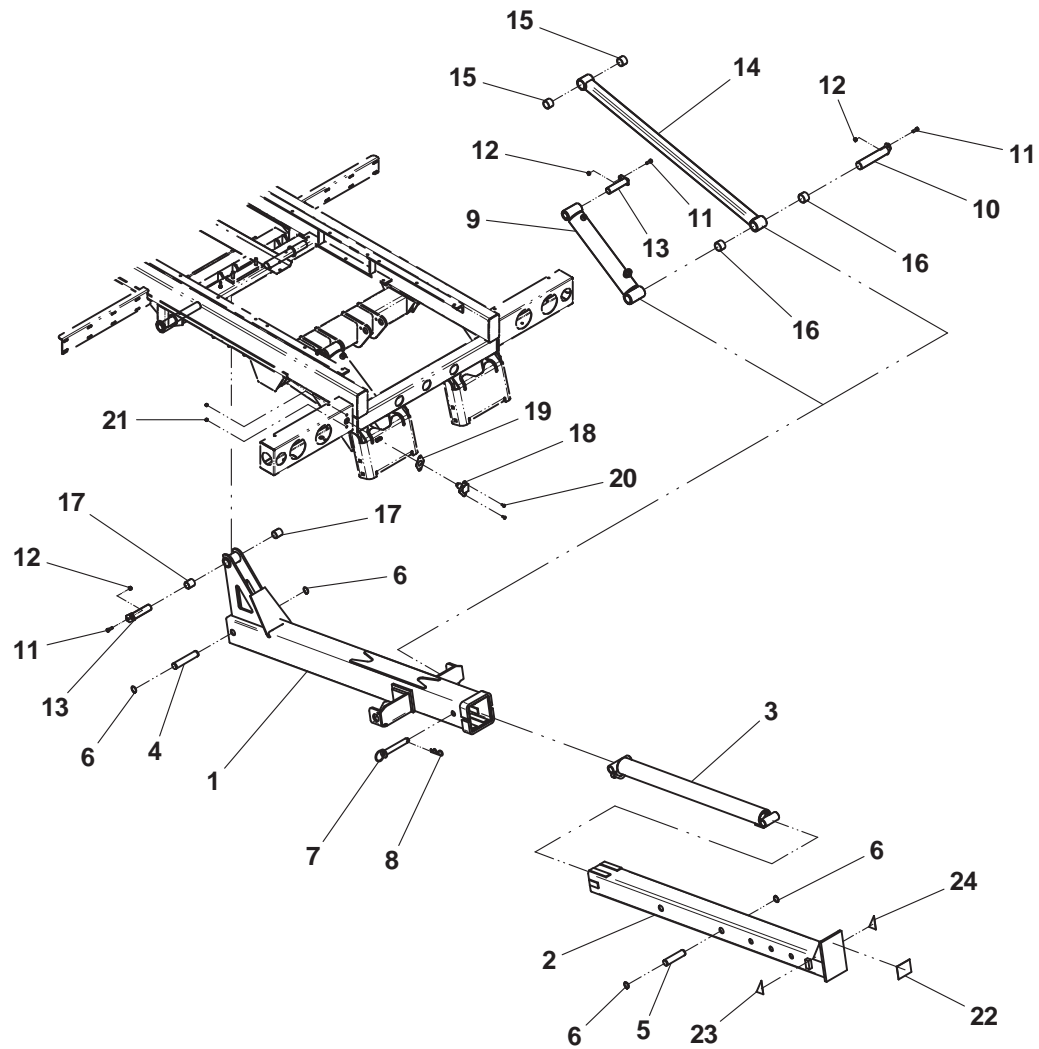

**PINTLE HITCH MOUNTING PLATE - HYDRAULIC EXTEND**

ITEM	PART NO.	DESCRIPTION	QTY
1	3170000276	Outer Boom Weld	1
2	3170000208	Inner Boom Weld	1
3	3320000116	Cylinder Assembly	1
4	4691000430	Pin	1
5	4691000429	Pin	1
6	7754000006	Retaining Ring	4
7	3691000073	Pin Weld	1
8	3691000064	Pin Weld	1
9	7115160950	Capscrew, 0.38"-16NC x 1.12"	1
10	7660162601	Locknut, 0.38"-16NC	1
11	3691000097	Pin Weld	1
12	7691000001	Hair Pin	2
13	7082000016*	Bushing	2
14	7291000010	4-Way Receptacle	1
15	7796000048	Gasket	1
16	7114140528	Screw, 0.25"-20NC x 0.63"	2
17	7660142601	Locknut, 0.25"-20NC	2
18	4330000002	Reflective Tape	1
19	4330000645	Reflective Tape, LH	1
20	4330000646	Reflective Tape, RH	1

\* included in Outer Boom Weld, P/N 3170000276

# PINTLE HITCH MOUNTING PLATE - HYDRAULIC EXTEND

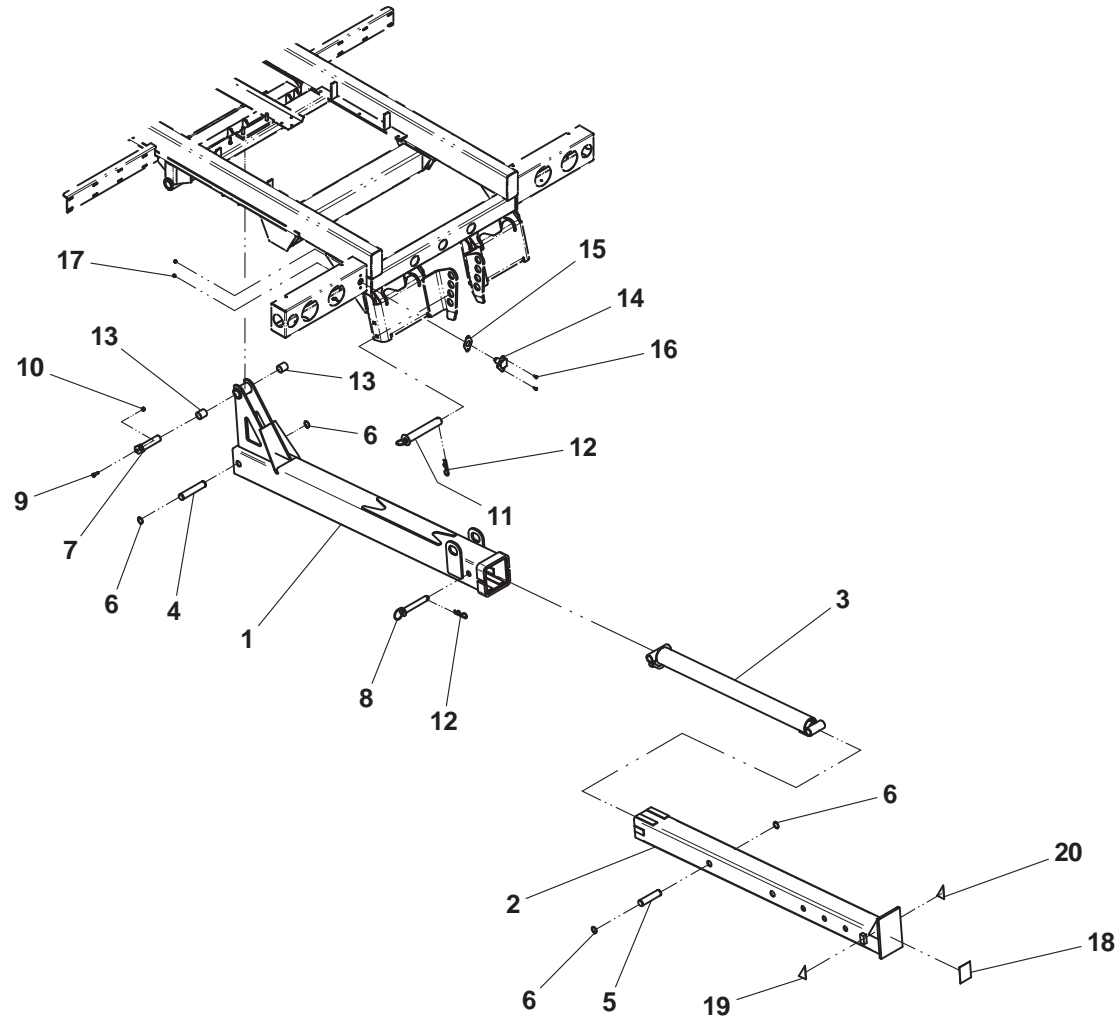

**PINTLE HITCH MOUNTING PLATE - MANUAL EXTEND**

ITEM	PART NO.	DESCRIPTION	QTY
1	3170000276	Outer Boom Weld	1
2	3170000208	Inner Boom Weld	1
3	3691000064	Pin Weld	1
4	7691000001	Hair Pin	2
5	3691000073	Pin Weld	1
6	7115160950	Capscrew, 0.38"-16NC x 1.12"	1
7	7660162601	Locknut, 0.38"-16NC	1
8	3691000097	Pin Weld	1
9	7082000016*	Bushing	2
10	7291000010	4-Way Receptacle	1
11	7796000048	Gasket	1
12	7114140528	Screw, 0.25"-20NC x 0.63"	2
13	7660142601	Locknut, 0.25"-20NC	2
14	4330000002	Reflective Tape	1
15	4330000645	Reflective Tape, LH	1
16	4330000646	Reflective Tape, RH	1

\* included in Outer Boom Weld, P/N 3170000276

# PINTLE HITCH MOUNTING PLATE - MANUAL EXTEND

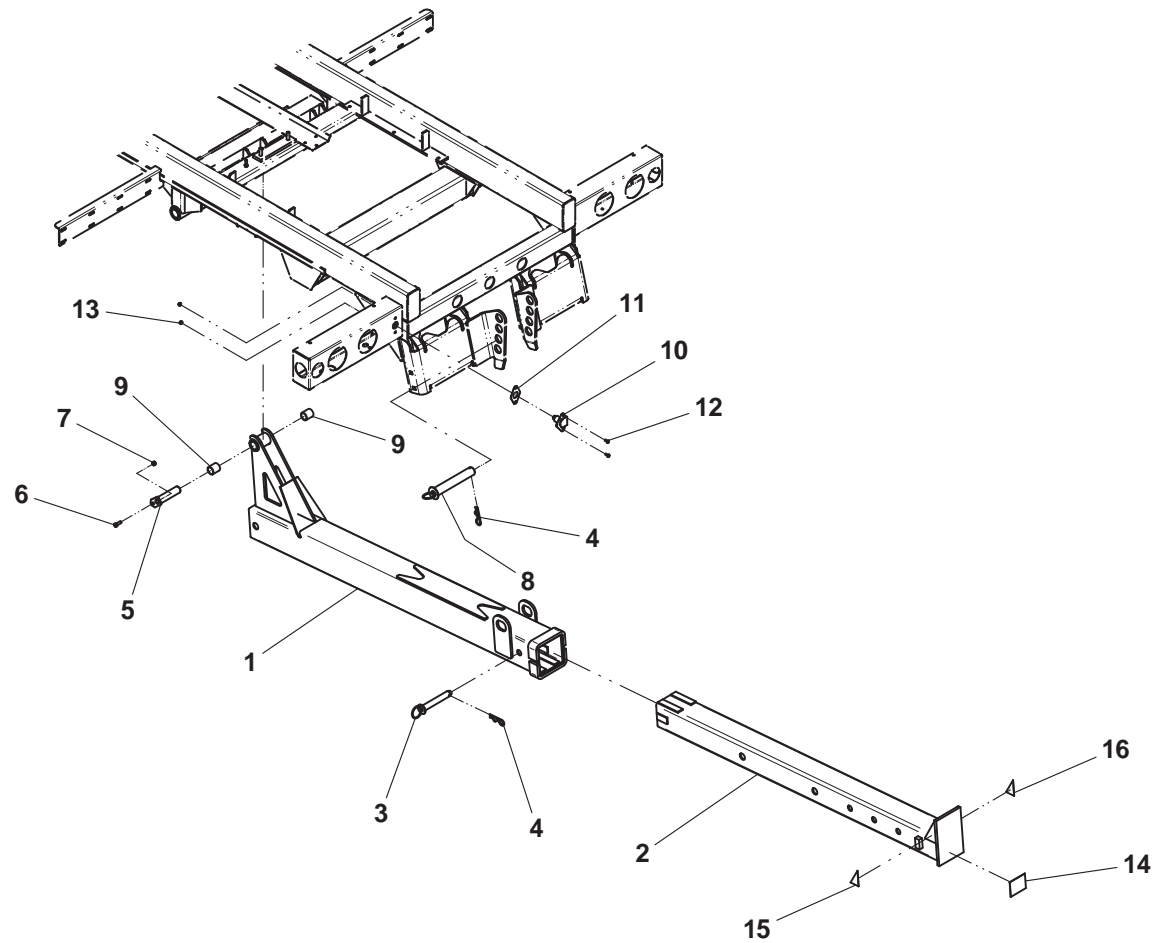

**TOWBAR - IRL**

ITEM	PART NO.	DESCRIPTION	QTY
1	3170000275	Outer Boom Weld	1
2	3170000048	Inner Boom Weld	1
3	3320000116	Cylinder Assembly	1
4	4691000430	Pin	1
5	4691000429	Pin	1
6	7754000006	Retaining Ring	4
7	7440030000	Grease Fitting	1
8	3320000114	Cylinder Assembly	2
9	3691000164	Pin Weld	2
10	7115160950	Capscrew, 0.38"-16NC x 1.12"	5
11	7660162601	Locknut, 0.38"-16NC	5
12	3691000073	Pin Weld	3
13	3020000097	Arm Weld	2
14	7082000017*	Bushing	4
15	7082000018*	Bushing	4
16	7082000016+	Bushing	2
17	3556000023	Tow Hitch Weld	1
18	4120000008	Capscrew, 1.50"-12NF x 6.38"	1
19	7912000011	Tube Rubber	2
20	7291000010	4-Way Receptacle	1
21	7796000048	Gasket	1
22	7114140528	Screw, 0.25"-20NC x 0.63"	2
23	7660142601	Locknut, 0.25"-20NC	2
24	7330000419	Reflective Tape	2
25	4330000001	Reflective Tape	1

\* included in Arm Weld, P/N 3020000097

+ included in Outer Boom Weld, P/N 3170000275



# TOWBAR - IRL

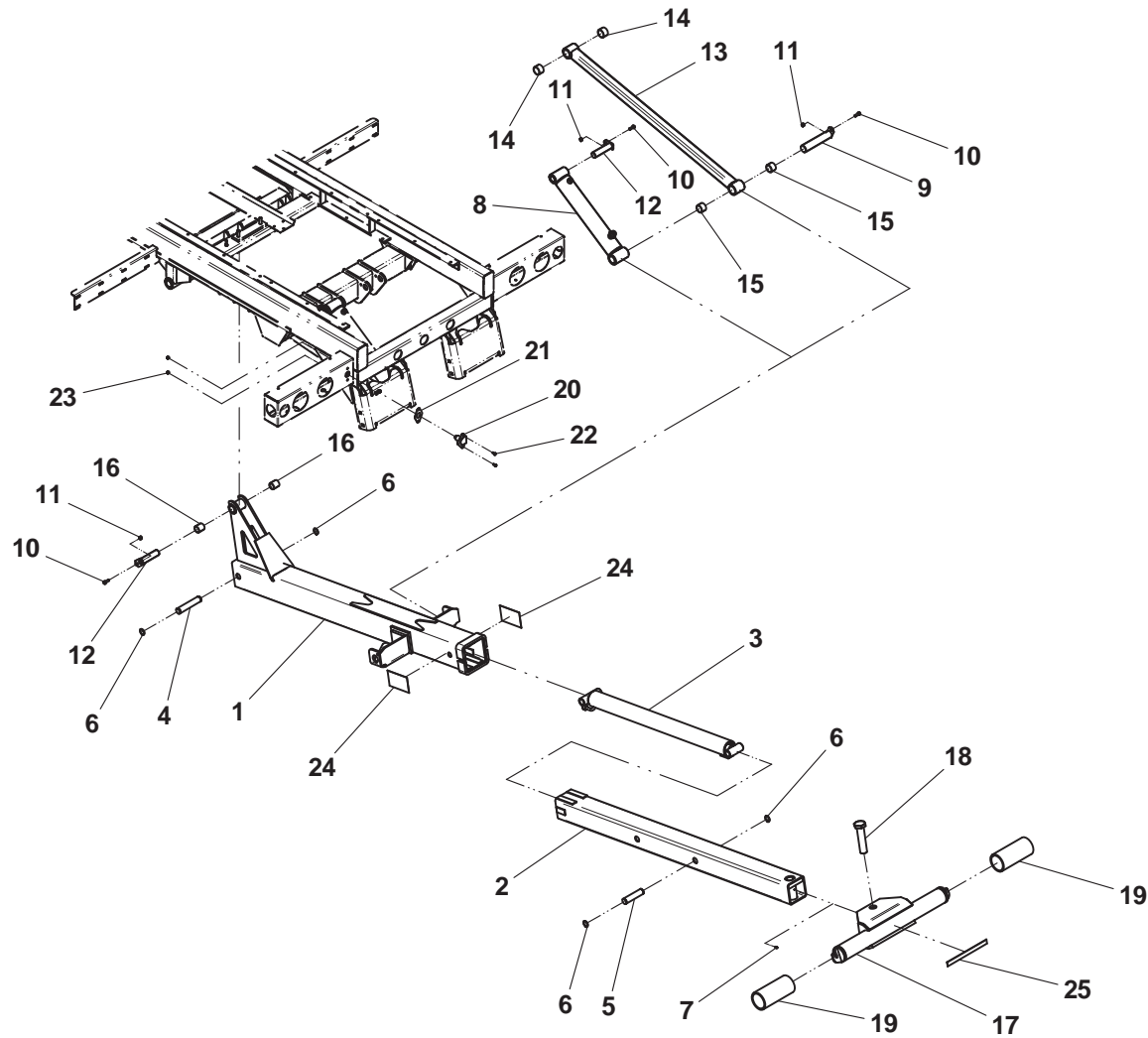

**TOWBAR - HYDRAULIC EXTEND**

ITEM	PART NO.	DESCRIPTION	QTY
1	3170000276	Outer Boom Weld	1
2	3170000048	Inner Boom Weld	1
3	3320000116	Cylinder Assembly	1
4	4691000430	Pin	1
5	4691000429	Pin	1
6	7754000006	Retaining Ring	4
7	7440030000	Grease Fitting	1
8	3691000073	Pin Weld	1
9	7115160950	Capscrew, 0.38"-16NC x 1.12"	1
10	7660162601	Locknut, 0.38"-16NC	1
11	3691000097	Pin Weld	1
12	7691000001	Hair Pin	1
13	7082000016*	Bushing	2
14	3556000023	Tow Hitch Weld	1
15	4120000008	Capscrew, 1.50"-12NF x 6.38"	1
16	7912000011	Tube Rubber	2
17	7291000010	4-Way Receptacle	1
18	7796000048	Gasket	1
19	7114140528	Screw, 0.25"-20NC x 0.63"	2
20	7660142601	Locknut, 0.25"-20NC	2
21	4330000002	Reflective Tape	2
22	4330000001	Reflective Tape	1

\* included in Outer Boom Weld, P/N 3170000276

# TOWBAR - HYDRAULIC EXTEND

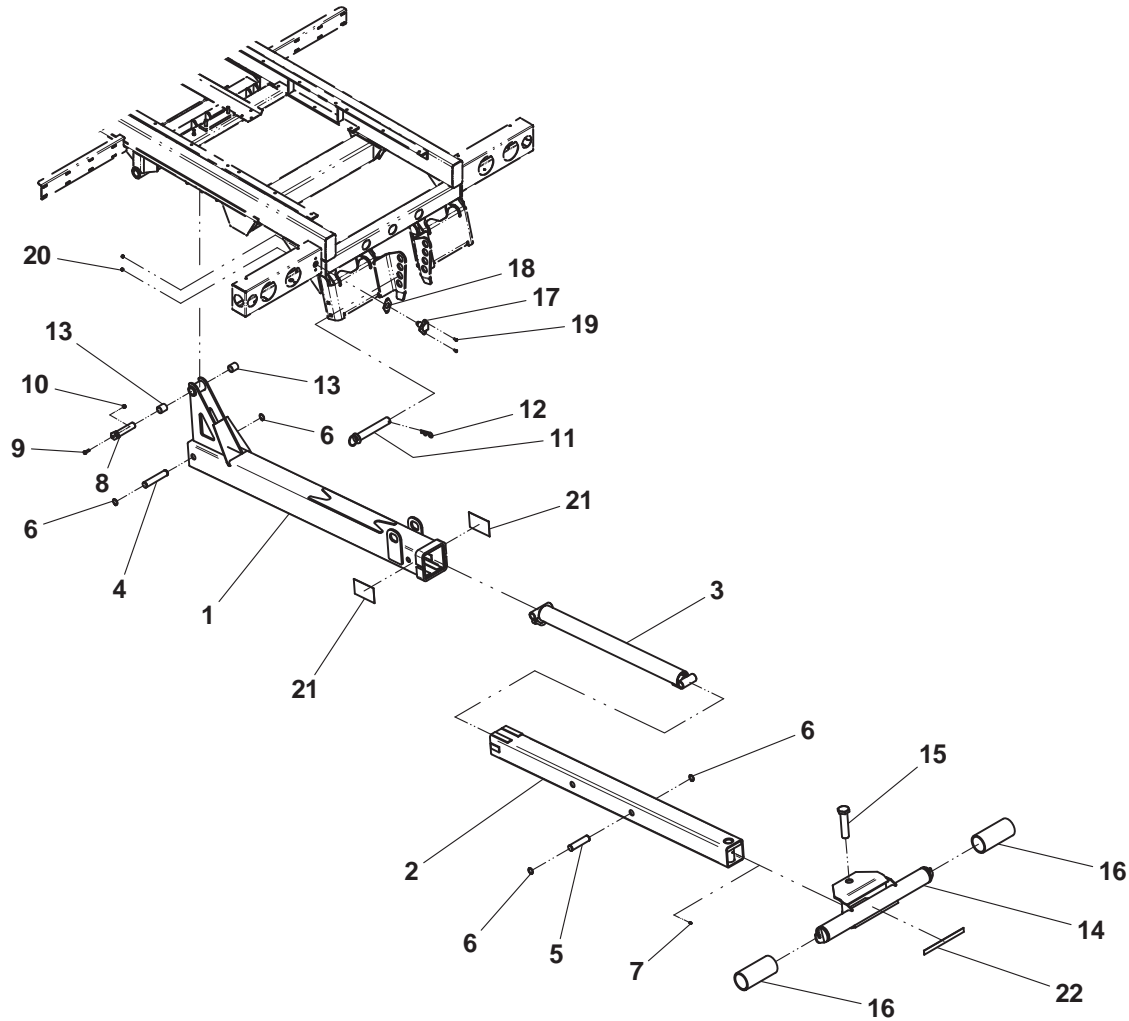

**ROLL CYLINDER ASSEMBLY - P/N 3320000236**

ITEM	PART NO.	DESCRIPTION	QTY
1	3071000218	Barrel Weld	1
2	4763000204	Rod	1
3	4698000007*	Piston	1
4	7754000003* #	Wear Ring	2
5	7796000063* #	Piston Locking "T" Seal	1
6	7755224609* #	Back-Up Ring	2
7	7755224000* #	"O" Ring	1
8	4553000008^	Head	1
9	7755334000^ #	"O" Ring	1
10	7755334609^ #	Back-Up Ring	1
11	7754000004^ #	Wear Ring	1
12	7796000024^ #	Rod Seal	1
13	7796000008^ #	Rod Wiper Seal	1
14	7754000002 #	Retaining Ring	1
15	7754000026 #	Retaining Ring	1
16	7661000034	Locknut	2

\* included in Piston Assembly, P/N 3698000001

^ included in Head Assembly, P/N 3553000011

# available only in Service Kit #7577250024

# ROLL CYLINDER ASSEMBLY - P/N 3320000236

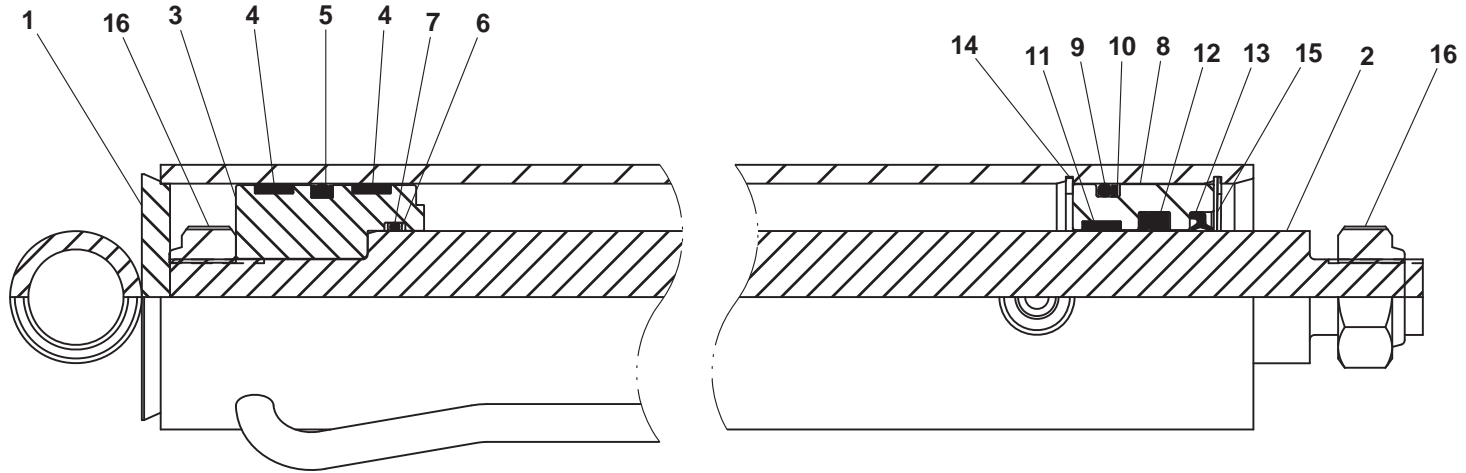

**TILT CYLINDER ASSEMBLY (OUTBOARD) - P/N 3320000113**

ITEM	PART NO.	DESCRIPTION	QTY
1	3071000104	Barrel Weld	1
2	3763000117	Rod Weld	1
3	4698000015*	Piston	1
4	7754000053* #	Wear Ring	2
5	7796000067* #	Piston Locking "T" Seal	1
6	7755222609* #	Back-Up Ring	2
7	7755222000* #	"O" Ring	1
8	4553000016^	Head	1
9	7755330000^ #	"O" Ring	1
10	7755330609^ #	Back-Up Ring	1
11	7754000054^ #	Wear Ring	1
12	7796000045^ #	Rod Seal	1
13	7796000046^ #	Rod Wiper Seal	1
14	7754000051#	Retaining Ring	2
15	7661000034	Locknut	1
16	7082000016	Bearing	4

\* included in Piston Assembly, P/N 3698000006

^ included Head Assembly, P/N 3553000016

# available only in Service Kit #7577250206

# TILT CYLINDER ASSEMBLY (OUTBOARD) - P/N 3320000113

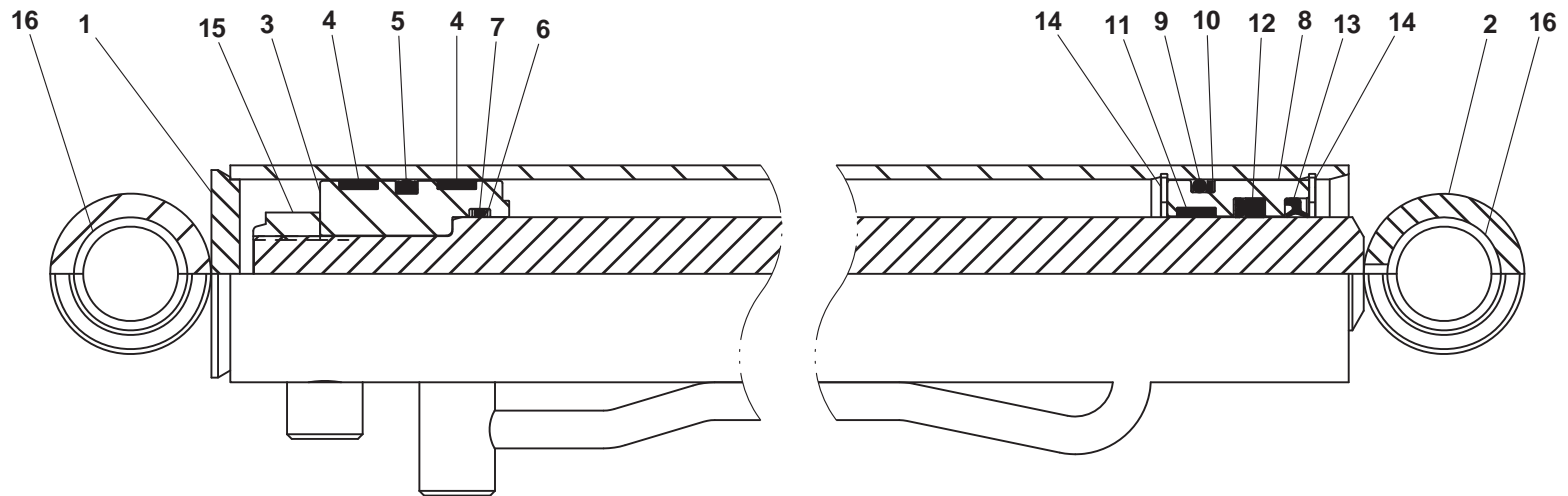

**TILT CYLINDER ASSEMBLY - P/N 3320000122**

ITEM	PART NO.	DESCRIPTION	QTY
1	3071000117	Barrel Weld	1
2	3763000127	Rod Weld	1
3	4698000007*	Piston	1
4	7754000003* #	Wear Ring	2
5	7796000063* #	Piston Locking "T" Seal	1
6	7755224609* #	Back-Up Ring	2
7	7755224000* #	"O" Ring	1
8	4553000008^	Head	1
9	7755330008^ #	"O" Ring	1
10	7755334609^ #	Back-Up Ring	1
11	7754000004^ #	Wear Ring	1
12	7796000045^ #	Rod Seal	1
13	7796000024^ #	Rod Wiper Seal	1
14	7754000002#	Retaining Ring	1
15	7754000026#	Retaining Ring	1
16	7661000034	Locknut	1
17	7082000016	Bearing	4

\* included in Piston Assembly, P/N 3698000001

^ included Head Assembly, P/N 3553000011

# available only in Service Kit #7577250042



# TILT CYLINDER ASSEMBLY - P/N 3320000122

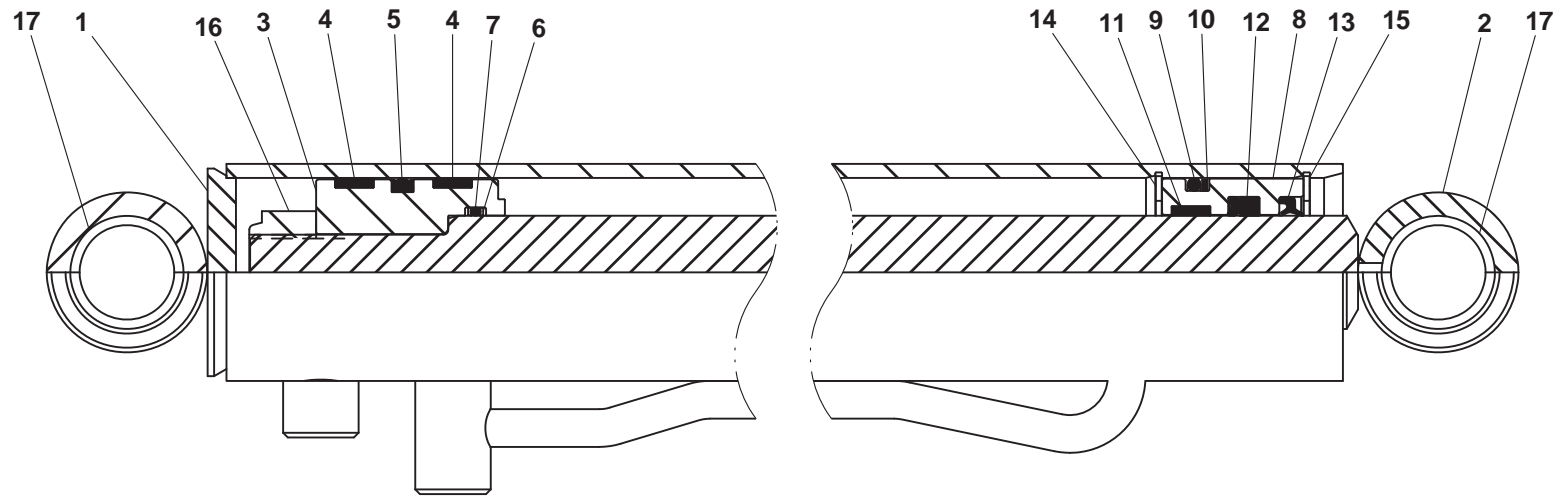

**TILT CYLINDER ASSEMBLY (INBOARD) - P/N 3320000120**

ITEM	PART NO.	DESCRIPTION	QTY
1	3071000111	Barrel Weld	1
2	3763000123	Rod Weld	1
3	4698000015*	Piston	1
4	7754000053* #	Wear Ring	2
5	7796000067* #	Piston Locking "T" Seal	1
6	7755222609* #	Back-Up Ring	2
7	7755222000* #	"O" Ring	1
8	4553000016^	Head	1
9	7755330000^ #	"O" Ring	1
10	7755330609^ #	Back-Up Ring	1
11	7754000054^ #	Wear Ring	1
12	7796000045^ #	Rod Seal	1
13	7796000046^ #	Rod Wiper Seal	1
14	7754000051#	Retaining Ring	2
15	7661000011	Locknut	1
16	7082000016	Bearing	4

\* included in Piston Assembly, P/N 3698000006

^ included in Head Assembly, P/N 3553000016

# available only in Service Kit #7577250206

# TILT CYLINDER ASSEMBLY (INBOARD) - P/N 3320000120

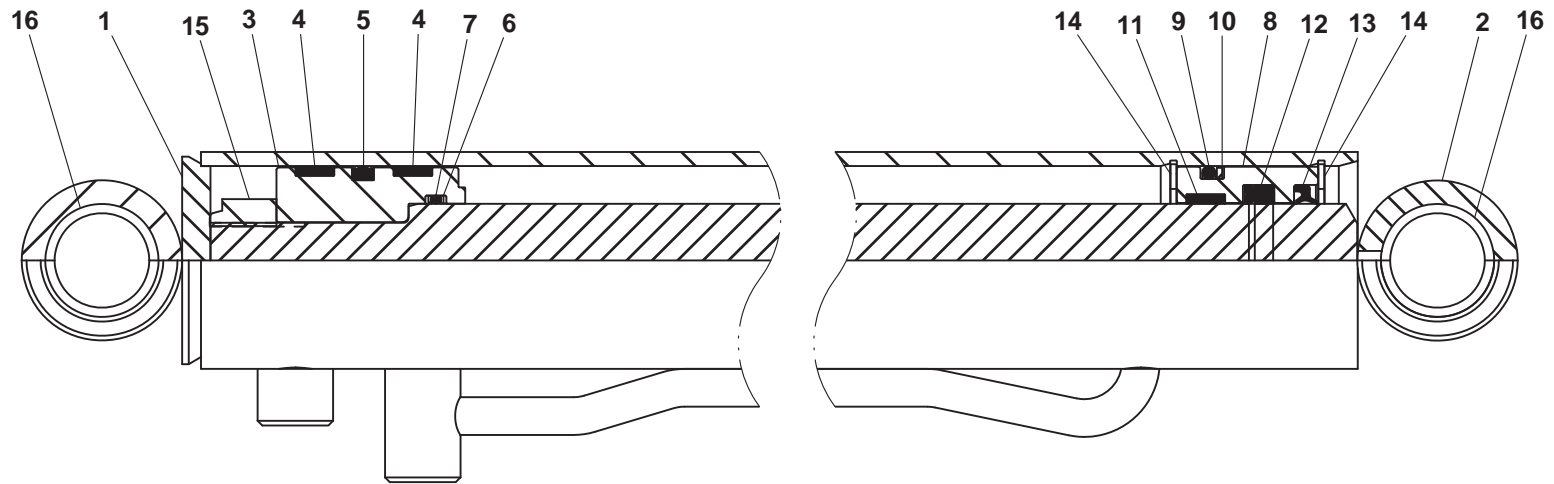

**WHEEL LIFT EXTEND CYLINDER ASSEMBLY - P/N 3320000115**

ITEM	PART NO.	DESCRIPTION	QTY
1	3071000106	Barrel Weld	1
2	3763000119	Rod Weld	1
3	4698000015*	Piston	1
4	7754000053* #	Wear Ring	2
5	7796000067* #	Piston Locking "T" Seal	1
6	7755222609* #	Back-Up Ring	2
7	7755222000* #	"O" Ring	1
8	4553000016^	Head	1
9	7755330000^ #	"O" Ring	1
10	7755330609^ #	Back-Up Ring	1
11	7754000054^ #	Wear Ring	1
12	7796000045^ #	Rod Seal	1
13	7796000046^ #	Rod Wiper Seal	1
14	7754000051#	Retaining Ring	2
15	7661000034	Locknut	1

\* included in Piston Assembly, P/N 3698000006

^ included in Head Assembly, P/N 3553000016

# available only in Service Kit #7577250206

**WHEEL LIFT EXTEND CYLINDER ASSEMBLY - P/N 3320000115**

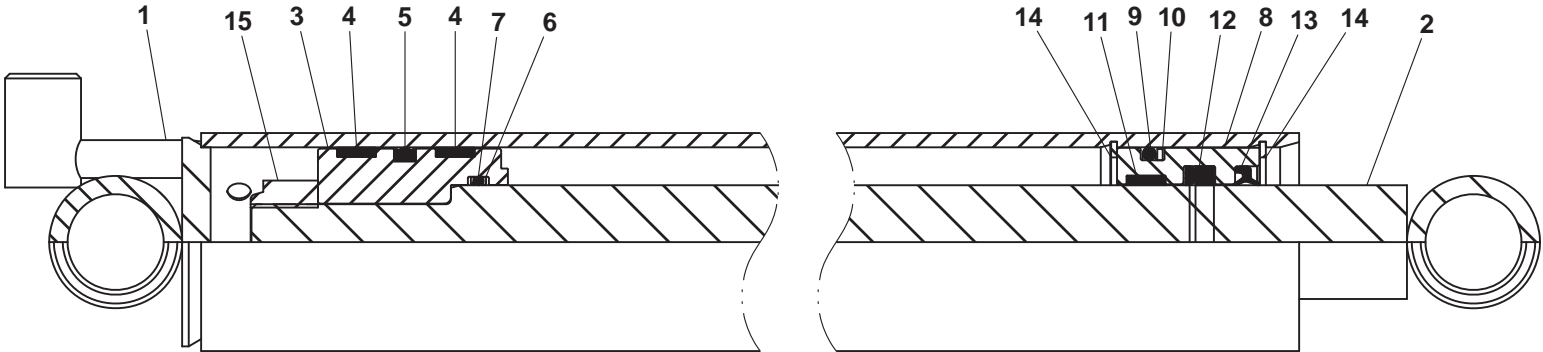

**IRL CYLINDER ASSEMBLY - P/N 3320000114 & 3320000134**

ITEM	PART NO.	DESCRIPTION	QTY
1	3071000105	Barrel Weld (auto grids)	1
	3017000131	Barrel Weld (auto grids)	
2	3763000118	Rod Weld (manual grids)	1
	3763000139	Rod Weld (auto grids)	
3	4698000007*	Piston	1
4	7754000003* #	Wear Ring	2
5	7796000063* #	Piston Locking "T" Seal	1
6	7755224609* #	Back-Up Ring	2
7	7755224000* #	"O" Ring	1
8	4553000008^	Head	1
9	7755334000^ #	"O" Ring	1
10	7755334609^ #	Back-Up Ring	1
11	7754000004^ #	Wear Ring	1
12	7796000024^ #	Rod Seal	1
13	7796000008^ #	Rod Wiper Seal	1
14	7754000002 #	Retaining Ring	1
15	7754000026 #	Retaining Ring	1
16	7661000034	Locknut	1
17	7082000016	Bearing	2
18	7082000018	Bearing	2

\* included in Piston Assembly, P/N 3698000001

^ included in Head Assembly, P/N 3553000011

# available only in Service Kit #7577250024

# IRL CYLINDER ASSEMBLY - P/N 3320000114 & 3320000134

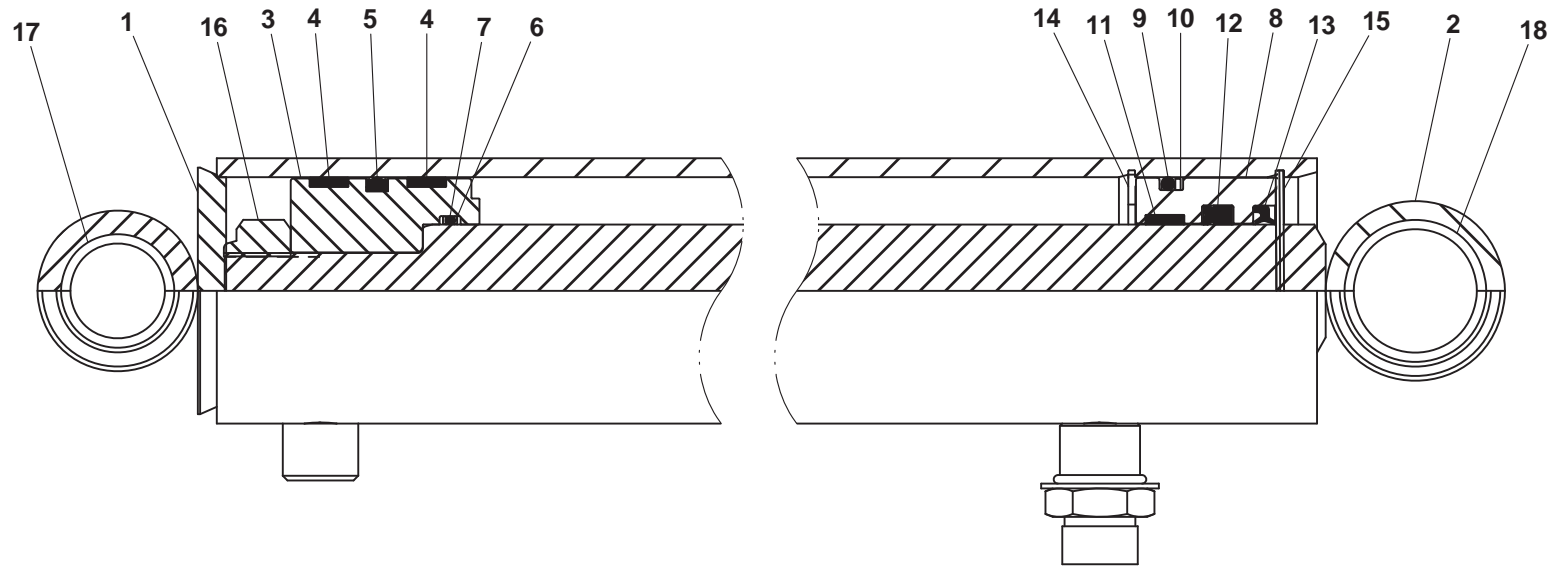

**ZOD CYLINDER ASSEMBLY - P/N 3320000118, 3320000135 & 7330000157**

ITEM	PART NO.	DESCRIPTION	QTY
1	3071000109	Barrel Weld (manual grids)	1
	3071000139	Barrel Weld (auto grids, std frame))	
	3071000103	Barrel Weld (auto grids, high frame)	
2	3763000122	Rod Weld (manual grid)	1
	3763000140	Rod Weld (auto grids, std frame)	
	3763000170	Rod Weld (auto grids, high frame)	
3	4698000015*	Piston	1
4	7754000053* #	Wear Ring	2
5	7796000067* #	Piston Locking "T" Seal	1
6	7755224609* #	Back-Up Ring	2
7	7755224000* #	"O" Ring	1
8	4553000016^	Head	1
9	7755330000^ #	"O" Ring	1
10	7755330609^ #	Back-Up Ring	1
11	7754000054^ #	Wear Ring	1
12	7796000045^ #	Rod Seal	1
13	7796000046^ #	Rod Wiper Seal	1
14	7754000051 #	Retaining Ring	2
15	7661000034	Locknut	1
16	7082000016	Bearing	4

\* include in Piston Assembly, P/N 3698000006

^ included in Head Assembly, P/N 3553000016

# available only in Service Kit #7577250206



ZOD CYLINDER ASSEMBLY - P/N 3320000118, 3320000135 & 3320000157

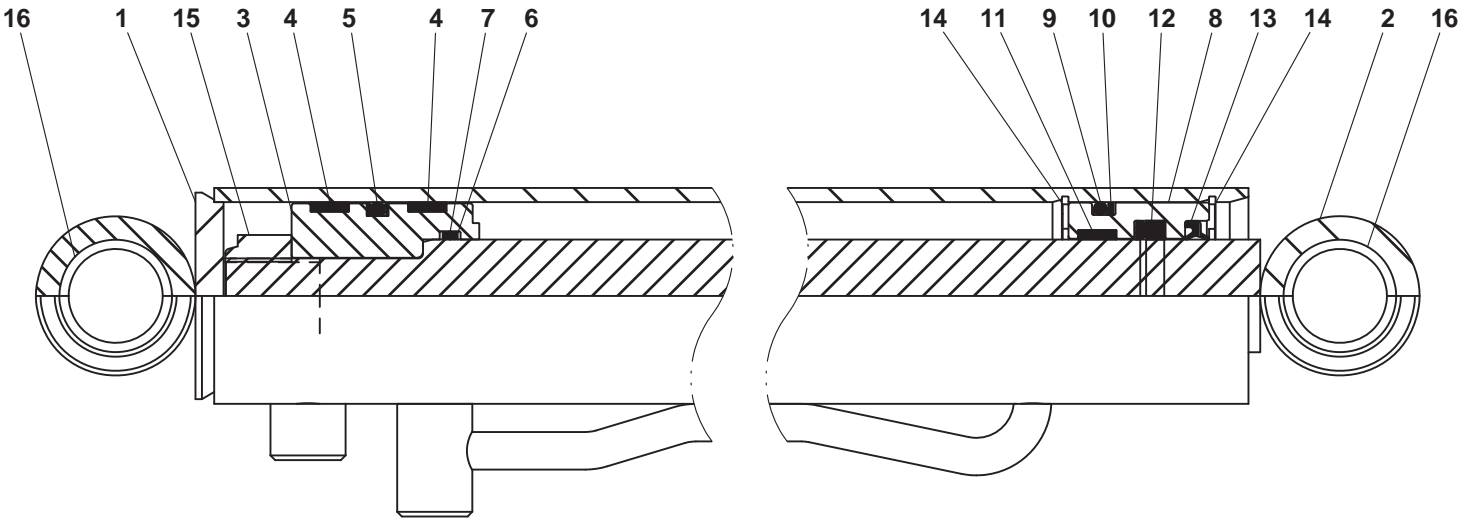

**STABILIZER CYLINDER ASSEMBLY - P/N 3320000119**

ITEM	PART NO.	DESCRIPTION	QTY
1	3071000110	Barrel Weld	1
2	3763000118	Rod Weld	1
3	4698000007*	Piston	1
4	7754000003* #	Wear Ring	2
5	7796000063* #	Piston Locking "T" Seal	1
6	7755224609* #	Back-Up Ring	2
7	7755224000* #	"O" Ring	1
8	4553000008^	Head	1
9	7755334000^ #	"O" Ring	1
10	7755334609^ #	Back-Up Ring	1
11	7754000004^ #	Wear Ring	1
12	7796000024^ #	Rod Seal	1
13	7796000008^ #	Rod Wiper Seal	1
14	7754000002 #	Retaining Ring	1
15	7754000026 #	Retaining Ring	1
16	7661000034	Locknut	1
17	7082000016	Bearing	2
18	7082000018	Bearing	2

\* included in Piston Assembly, P/N 3698000001

^ included in Head Assembly, P/N 3553000011

# available only in Service Kit #7577250024

# STABILIZER CYLINDER ASSEMBLY - P/N 3320000119

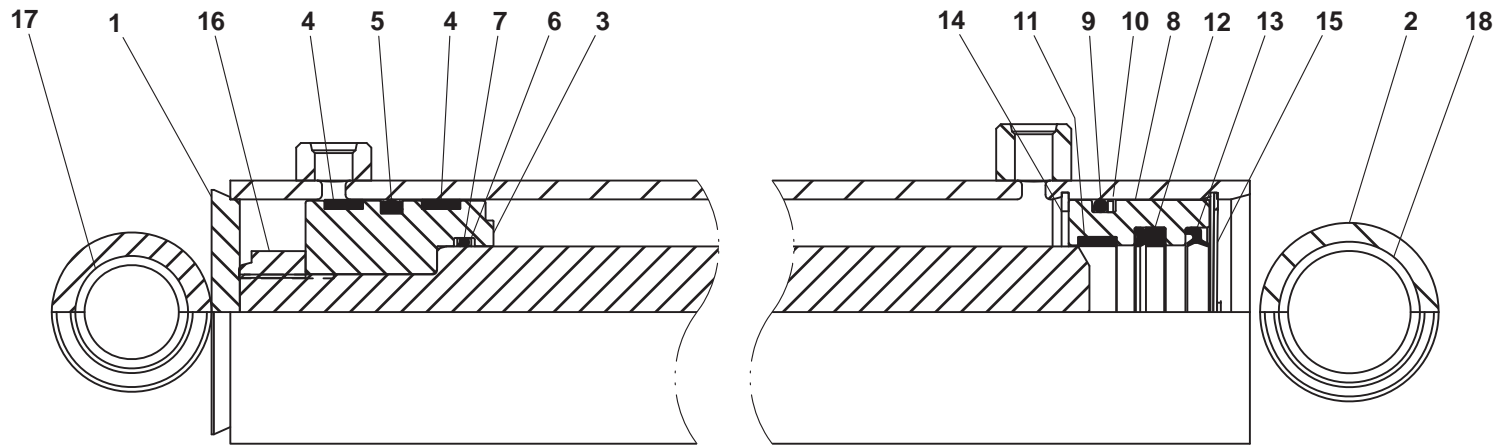

**TOW OPTION HYDRAULIC EXTEND CYLINDER ASSEMBLY - P/N 3320000116 AND P/N 3320000117**

ITEM	PART NO.	DESCRIPTION	QTY
1	3071000107	Barrel Weld (IRL tow option extend)	1
	3071000108	Barrel Weld (stabilizer tow option extend)	
2	3763000120	Rod Weld (IRL tow option extend)	1
	3763000121	Rod Weld (stabilizer tow option extend)	
3	4698000007*	Piston	1
4	7754000003* #	Wear Ring	2
5	7796000063* #	Piston Locking "T" Seal	1
6	7755224609* #	Back-Up Ring	2
7	7755224000* #	"O" Ring	1
8	4553000008^	Head	1
9	7755334000^ #	"O" Ring	1
10	7755334609^ #	Back-Up Ring	1
11	7754000004^ #	Wear Ring	1
12	7796000024^ #	Rod Seal	1
13	7796000008^ #	Rod Wiper Seal	1
14	7754000002 #	Retaining Ring	1
15	7754000026 #	Retaining Ring	1
16	7661000034	Locknut	1

\* included in Piston Assembly, P/N 3698000001

^ included in Head Assembly, P/N 3553000011

# available only in Service Kit #7577250024

# TOW OPTION HYDRAULIC EXTEND CYLINDER ASSEMBLY - P/N 3320000116 AND P/N 3320000117

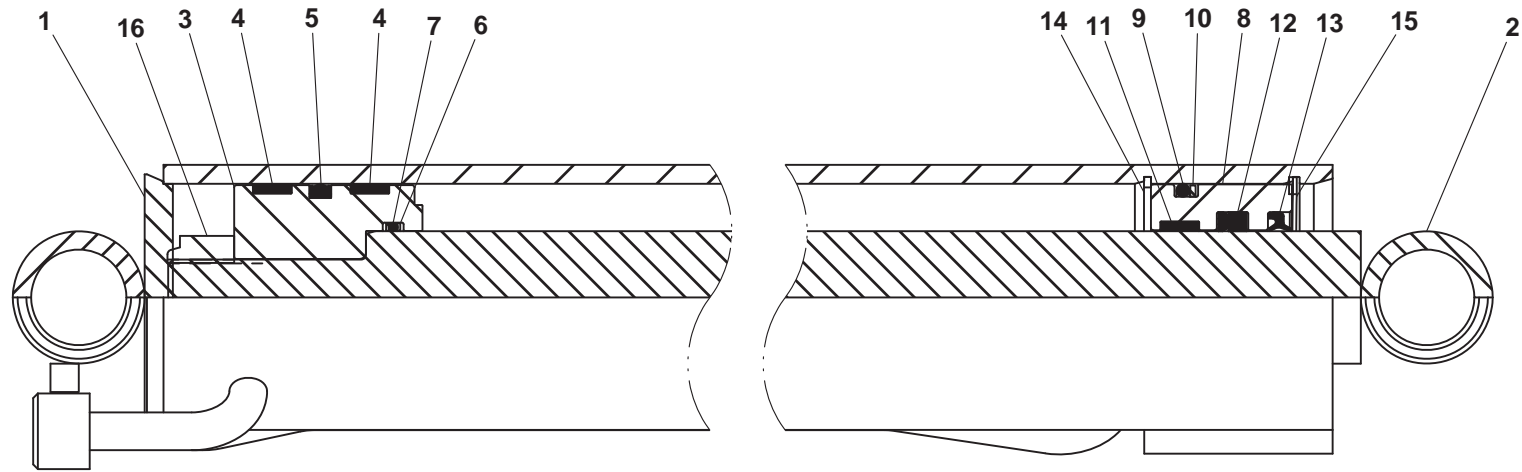

**LIGHTBARS**

ITEM	PART NO.	DESCRIPTION	QTY
1	7590000363	Lightbar, Amber LED	1
2	4178000402	Bracket (standard mount)	2
	4178000437	Bracket (high mount)	
3	7115180850	Capscrew, 0.50"-13NC x 1.00"	2
4	7950180252	Flatwasher, 0.50" ID	2
5	7950180000	Lockwasher, 0.50" ID	2
6	7949000072^	Fender Washer, 0.50" ID	2
7	7660182301^	Locknut Flanged, 0.50"-13NC	2
8	7280000011^	Clip, 0.44" Dia Push Mount	2

^ only required for Modular Headboard

# LIGHTBARS

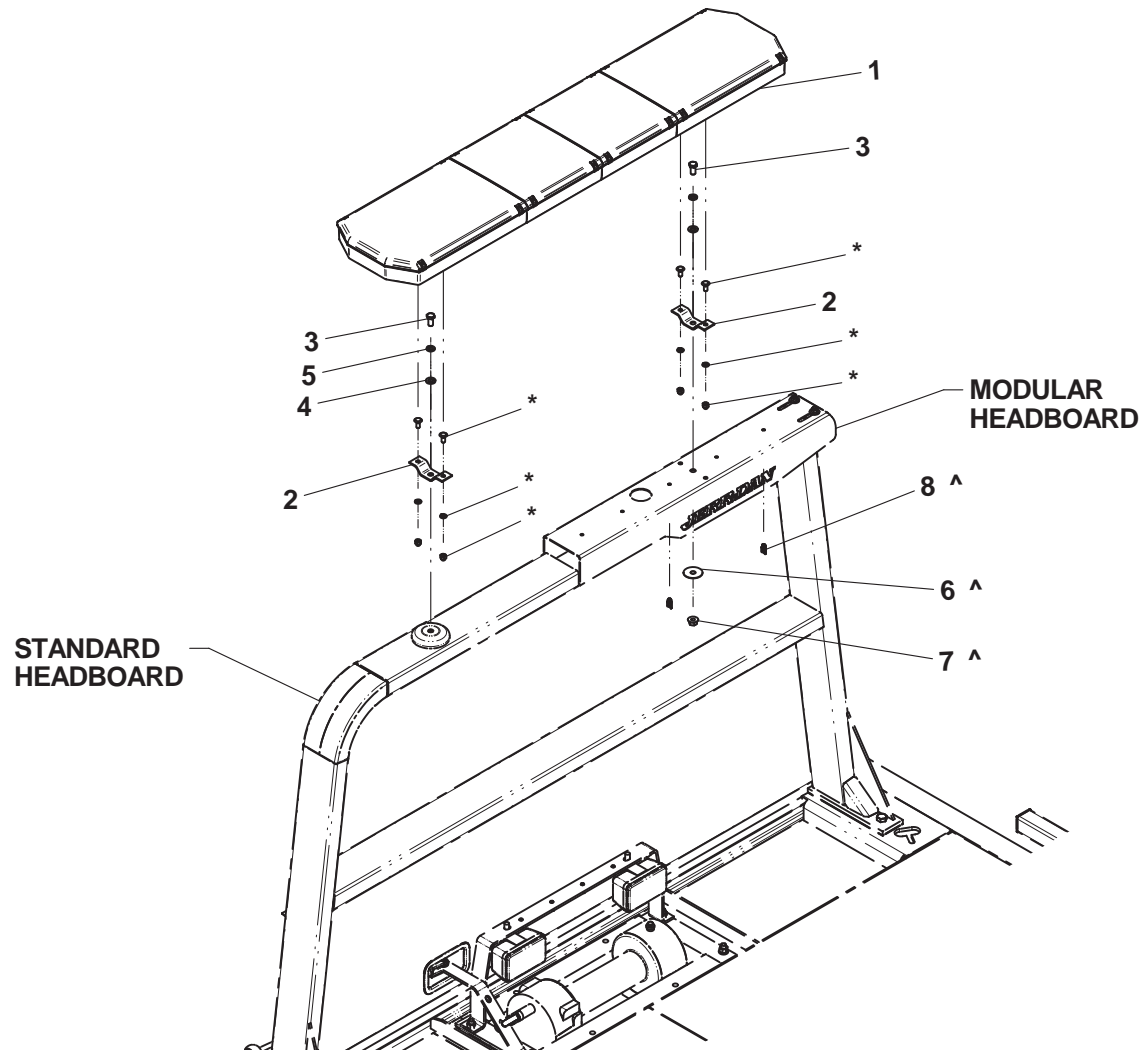

\* included in Lightbar  
^ only required for Modular Headboard

**SWITCH PANELS**

ITEM	PART NO.	DESCRIPTION	QTY
1	4178000403	Bracket - 1 Function Switch Panel	1
2	4178000427	Bracket - 2 Function Switch Panel	1
3	7870000083	Switch	1
4	7870000113	Switch Panel - 3 Function, Mini In-Dash	1
5	7870000100	Switch Panel - 3 Function, In-Dash	1
6	7870000106	Switch Panel - 5 Function, In-Dash	1
7	7870000134	Switch Panel - 3 Function, Under Dash	1
8	7870000137	Switch Panel - 5 Function, Under Dash	1
9	2870000022	Switch Panel - 3 Function, In-Dash for Ford F650/750	1
10	2870000021	Switch Panel - 5 Function, In-Dash for Ford F650/750	1
11	7870000053	Switch Panel - 3 Function, Under Dash	1
12	7870000063	Switch Panel - 5 Function, Under Dash	1
13	7870000076	Switch Panel - 3 Function, In-Dash for IHC4300/4400	1



# SWITCH PANELS

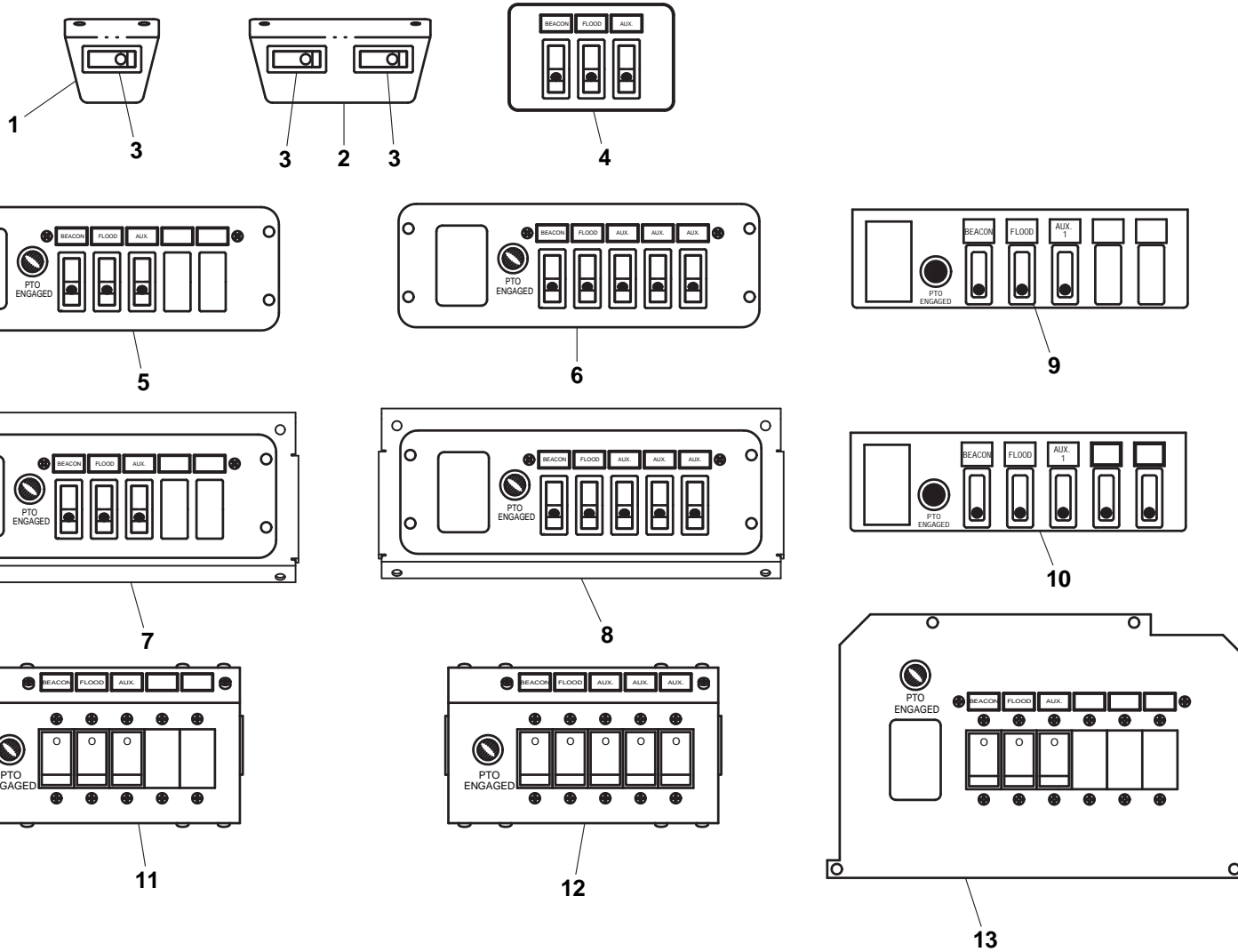

**WORK LIGHTS**

ITEM	PART NO.	DESCRIPTION	QTY
1	7590000223	Work Light	4
2	4178000402*	Bracket	2
3	7790151253*	Screw, 0.31"-18NC x 0.75	4
4	7493000003*	Grommet	2
5	7552000222	Harness - Headboard Work Lights	1
	7552000360	Harness - Headboard Work Lights (Bucket Rest Headboard Only)	1
6	4178000423	Bracket	1
7	7280000011	Clip - Winch Work Lights	6
	7280000011	Clip - Headboard Work Lights	8
8	4263000825^	Bracket	2
9	7115181050^	Capscrew, 0.50"-13NC x 1.25	2
10	7950180252^	Flatwasher, 0.50" ID	2
11	7660182301^	Locknut, 0.50"-13NC	2
12	7552000166	Harness - Winch Work Lights	1
13	7590000185	Work Light	2

\* only required for Standard or Bucket Rest Headboard

^ only required for Modular Headboard

# WORK LIGHTS

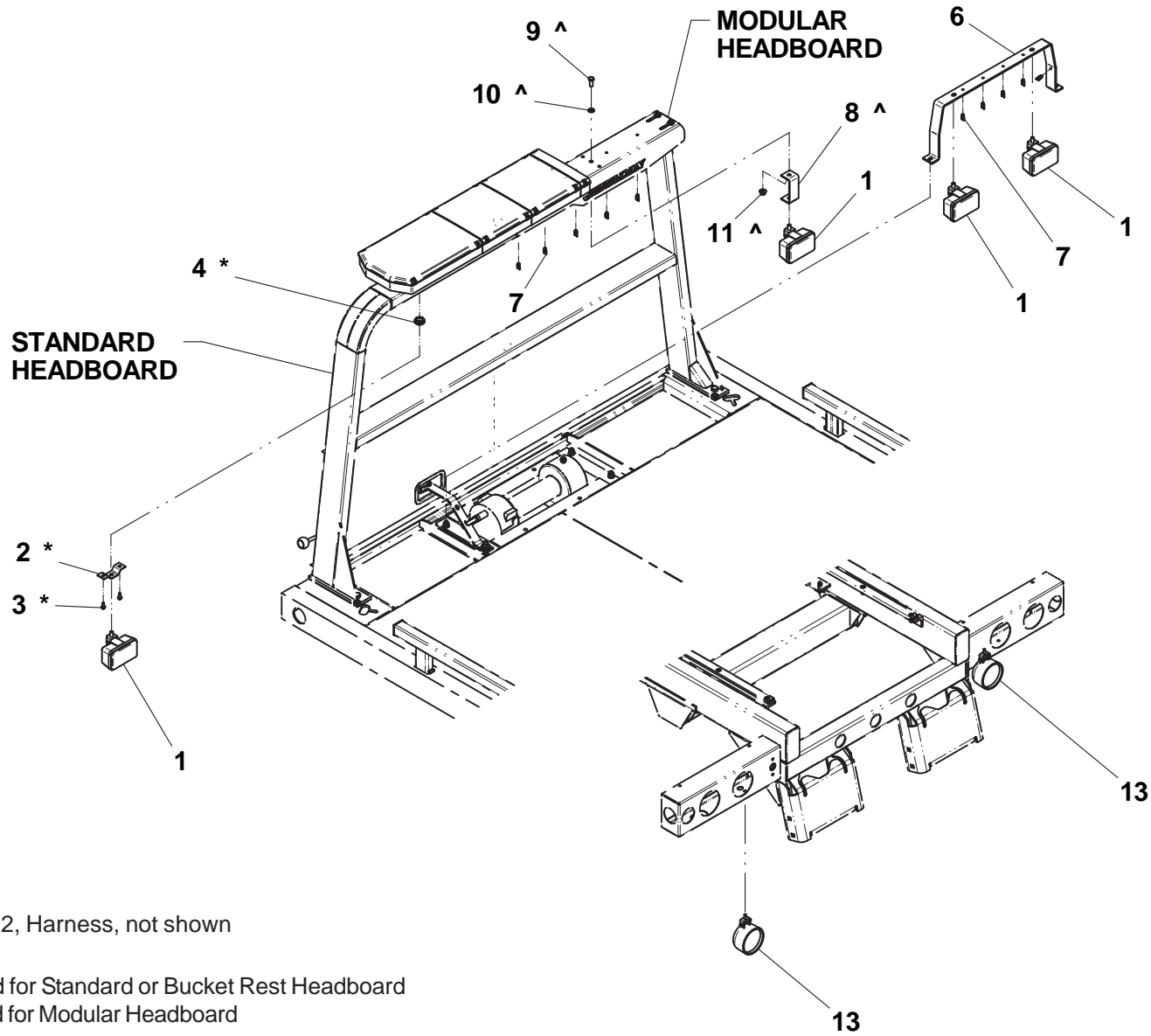

Items #5 & #12, Harness, not shown

\* only required for Standard or Bucket Rest Headboard

^ only required for Modular Headboard

**BOLT-ON D-RINGS**

ITEM	PART NO.	DESCRIPTION	QTY
1	3556000019	D-Ring	1
2	7115182050	Capscrew, 0.50"-13NC x 2.50"	2
3	7950180161	Flatwasher, 0.50" ID (aluminum decks only)	2
4	7660182601	Locknut, 0.50"-13NC	2

# BOLT-ON D-RINGS

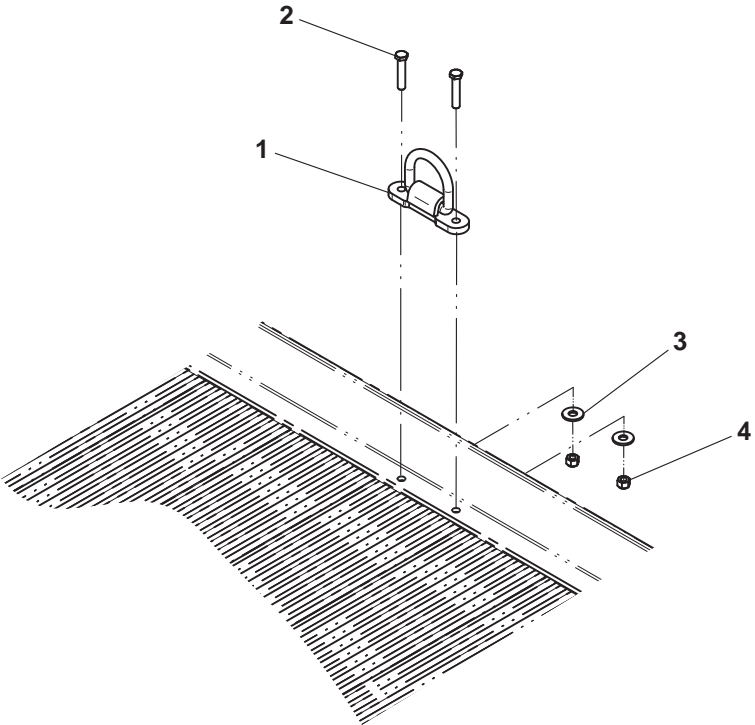

ALUMINUM DECK

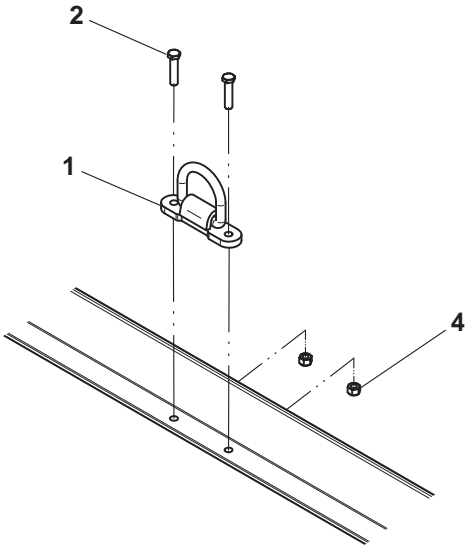

STEEL DECK

**1, 2, 3, 4 OR 5 REMOTE CONTROL OPERATIONS**

ITEM	PART NO.	DESCRIPTION	QTY	ITEM	PART NO.	DESCRIPTION	QTY
1	7005000003	Linear Actuator 12V	1*	18	4706005595	Plate (2, 3, 4, or 5 remote operations)	1
2	4706005361	Plate	2	19	7330000696	Decal - Controller Functions (3, 4, or 5 remote operations)	1
3	7115150864	Carriage Bolt, 0.31"-18NC x 1.00"	4	20	9295310032#	Transmitter (1 remote operation)	1
4	7950150161	Flatwasher, 0.31" ID	4		9295310033#	Transmitter (2 remote operations)	
5	7660152601	Locknut, 0.31"-18NC	4	21	9295310034#	Transmitter (3 remote operations)	1
6	4178000664	Bracket	1*		9295310036#	Transmitter (4 or 5 remote operations)	
7	4178000665	Bracket	1*		9295310030#	Belt Clip	
8	7115150864	Carriage Bolt, 0.31"-18NC x 1.00"	2*	22	9295310042#	Rubber Boot (1 or 2 remote operations)	1
9	7660152601	Locknut, 0.31"-18NC	2*		9295310029#	Rubber Boot (3, 4, or 5 remote operations)	
10	4691000141	Pin (3, 4 or 5 section control valve)	1	23	9295310037#	Receiver (1 remote operation)	1
	4691000373	Pin (6 section control valve)			9295310038#	Receiver (2 remote operations)	
	4691000374	Pin (7 section control valve)			9295310039#	Receiver (3 remote operations)	
11	4211000001	Bushing	4*	24	9295310050#	Receiver (4 or 5 remote operations)	1
12	7950220141	Flatwasher, 0.75" ID	4		7552000391	Harness (1 remote operation)	
13	7754000009	Retaining Ring	2	24	7552000392	Harness (2 remote operations)	1
14	7295000106	Controller (1 remote operation)	1		7552000393	Harness (3 remote operations)	
	7295000108	Controller (2 remote operations)			7552000426	Harness (4 or 5 remote operations)	
	7295000109	Controller (3 remote operations)					
	7295000111	Controller (4 or 5 remote operations)					
15	7114100810	Screw, #10-24NC x 1.00" (1 remote operation)		2			
	7114100810	Screw, #10-24NC x 1.00" (2, 3, 4, or 5 remote operations)	6				
16	7950140151	Flatwasher, 0.19" ID (1 remote operation)	2				
	7950140151	Flatwasher, 0.19" ID (2, 3, 4, or 5 remote operations)	8				
17	7660102604	Locknut, #10-18NC (1 remote operation)	2				
	7660102604	Locknut, #10-18NC (2, 3, 4, or 5 remote operations)	6				

\* quantities are for 1 remote operation, adjust quantities for 2, 3, 4, or 5 remote operations

# included with Controller, item #14

# 1, 2, 3, 4 OR 5 REMOTE CONTROL OPERATIONS

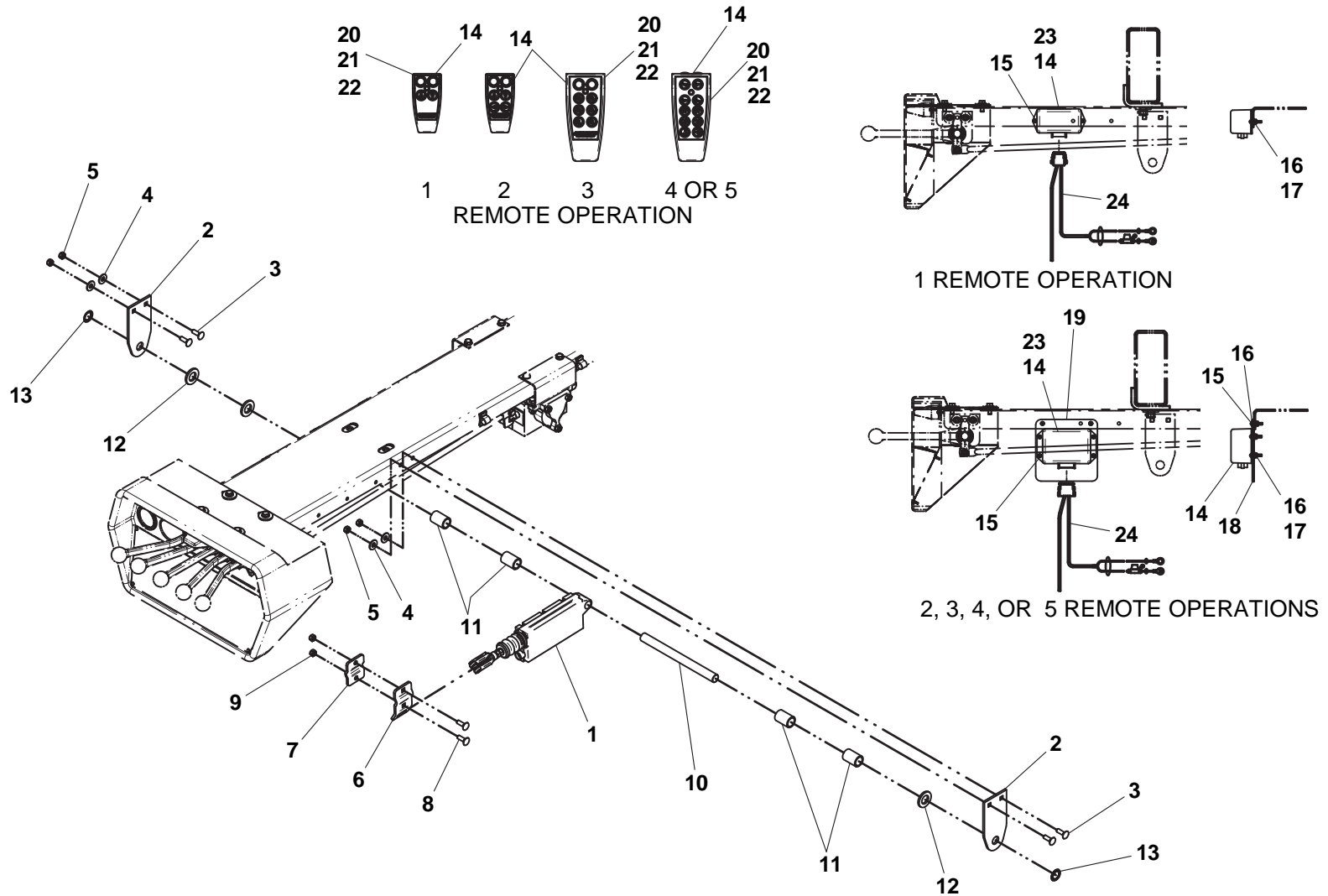

One Remote Operation shown

Items #19, Decal - Controller Functions, not shown

**6 OR 7 REMOTE CONTROL OPERATIONS**

ITEM	PART NO.	DESCRIPTION	QTY
1	7005000003	Linear Actuator 12V	1*
2	4706005361	Plate	2
3	7115150864	Carriage Bolt, 0.31"-18NC x 1.00"	4
4	7950150161	Flatwasher, 0.31" ID	4
5	7660152601	Locknut, 0.31"-18NC	4
6	4178000664	Bracket	1*
7	4178000665	Bracket	1*
8	7115150864	Carriage Bolt, 0.31"-18NC x 1.00"	2*
9	7660152601	Locknut, 0.31"-18NC	2*
10	4691000373	Pin (6 section control valve)	
	4691000374	Pin (7 section control valve)	
11	4211000001	Bushing	4*
12	7950220141	Flatwasher, 0.75" ID	4
13	7754000009	Retaining Ring	2
14	7295000102	Controller (6 remote operations)	1
	7295000103	Controller (7 remote operations)	
15	4706005396	Plate	1
16	4706003650	Plate	1
17	7115140650	Capscrew, 0.25"-20NC x 0.75"	5
18	7950140141	Flatwasher, 0.25" ID	5
19	7660142601	Locknut, 0.25"-20NC	5
20	7114080618	Capscrew, #8-32NC x 0.75"	4
21	7660082604	Locknut, #8-32NC	4
22	7104100613	Screw, #10-32NF x 0.34"	4
23	7661000007	Wellnut, #10-32NF	4
24	9295310026^	Transmitter (6 or 7 remote operations)	1
25	7330000612	Decal - Controller Functions	1

\* quantities are for 1 remote operation, adjust quantities for 6 or 7 remote operations

^ included with Controller, item # 14 (6 or 7 remote operations)



# 6 OR 7 REMOTE CONTROL OPERATIONS

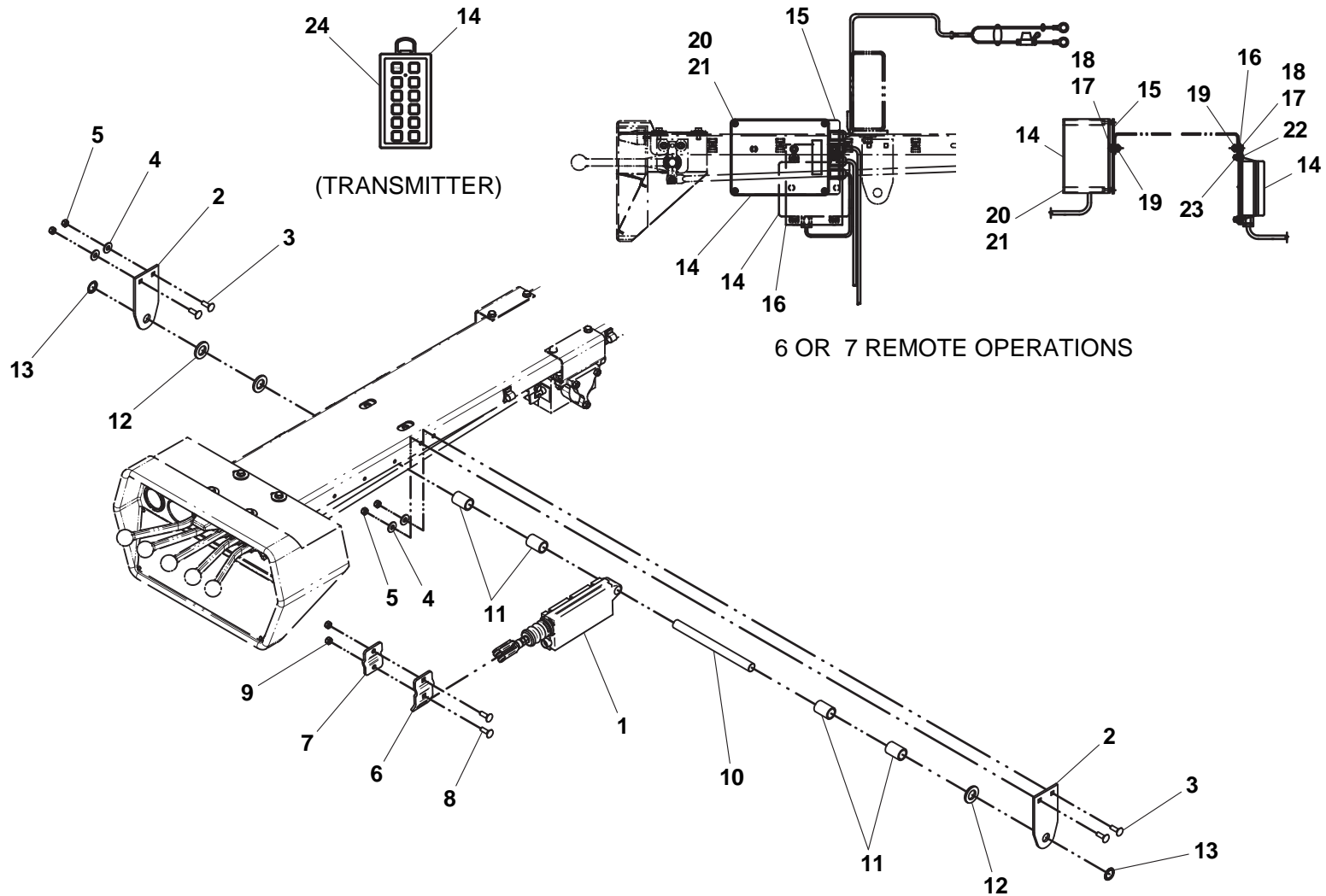

One Remote Operation shown

Item #25, Decal- Controller Functions, not shown

**REMOTE THROTTLE CONTROL**

ITEM	PART NO.	DESCRIPTION	QTY
1	7346000208	Pressure Switch	1
2	7552000241	Harness	1
3	7443000427*	Check Valve	1
4	7445060643*	Adapter	1
5	7443000432	Tee	1
6	7443000440	Fitting	1
7	7445040643	Adapter	1

\* also available in Check Valve w/ Adapter, P/N 7443000428.

# REMOTE THROTTLE CONTROL

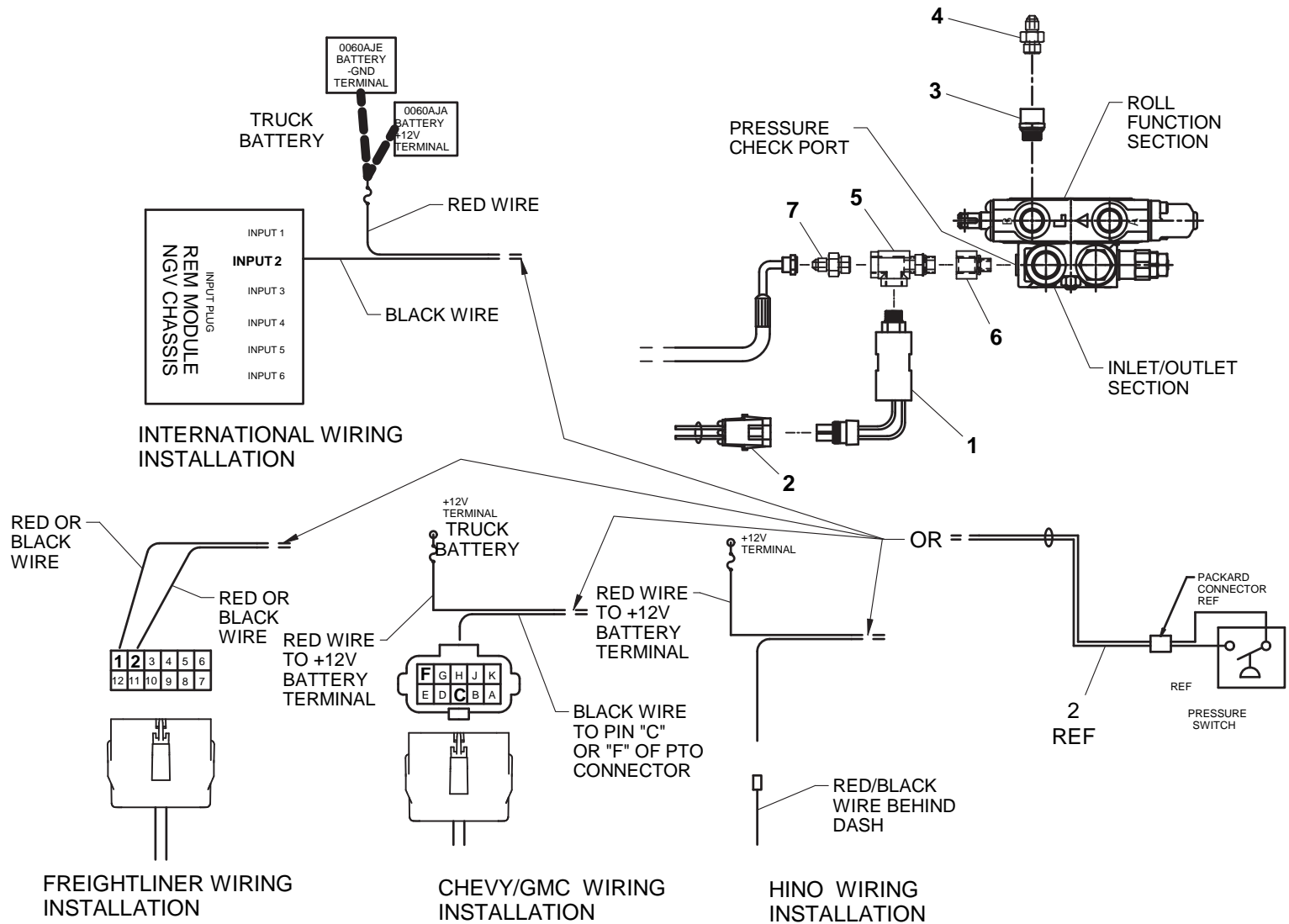

**GLAD HANDS AND 7- WAY CONNECTOR**

ITEM	PART NO.	DESCRIPTION	QTY
1	4178000666*	Bracket	1
2	7115181464*	Carriage Bolt, 0.50"-13NC x 1.75"	2
3	7660182601*	Locknut, 0.50"-13NC	2
4	7346000055+	Electrical Receptacle 7-way Connect	1
5	7346000078+	Electrical Boot	1
6	7111150813+	Capscrew, 0.31"-18NC x 1.00"	2
7	7660152601+	Locknut, 0.31"-18NC	2
8	7346000132	Electrical Adapter 7 to 4 way	1
9	7346000157	Electrical Adapter 7 to 6 way	1
10	7312000015^	Gladhand	1
11	7312000016^	Gladhand	1
12	7446502518^	Bulkhead Fitting	2
13	7446382506^	Connector	2
14	7577000145^	Seal Kit Gladhand	1
15	7565000014^	Airline Tubing	50 ft
16	7312000013^	Union	2

\* also available in Bracket Install Glad Hands and 7 Way, P/N 2178000037

+ also available in Electrical Install 7 Way Connector, P/N 2346000008

^ also available in Glad Hand Install, P/N 2002000016

## GLAD HANDS AND 7- WAY CONNECTOR

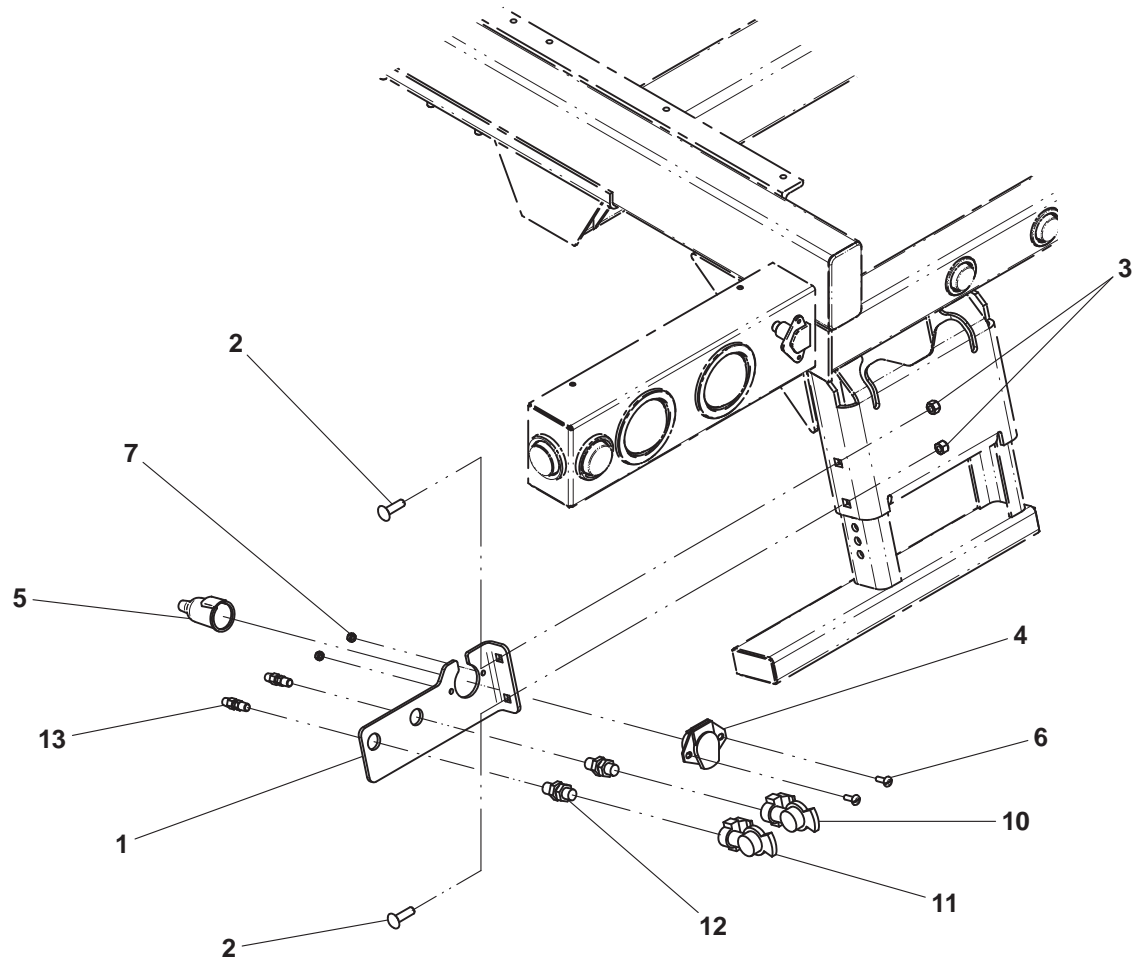

Item #8 Electrical Adapter 7 to 4 Way not shown  
Item #9 Electrical Adapter 7 to 6 Way not shown  
Item #14, Seal Kit Gladhand; #15, Airline Tubing; & #16, Union not shown

**AIR SUPPLY DISCONNECT**

ITEM	PART NO.	DESCRIPTION	QTY
1	7312000017	Coupling	1
2	7445080853	Elbow	1
3	7446502518	Bulkhead Fitting	1
4	7443000111	Elbow	1
5	7446382506	Connector	1
6	7565000014	Airline Tubing	32 ft
7	7935000120	Air Valve	1
8	7443000154	Bushing	1
9	7443000156	Nipple	1
10	7894000031	Cable Tie	6
11	7443000366	Fitting	1

# AIR SUPPLY DISCONNECT

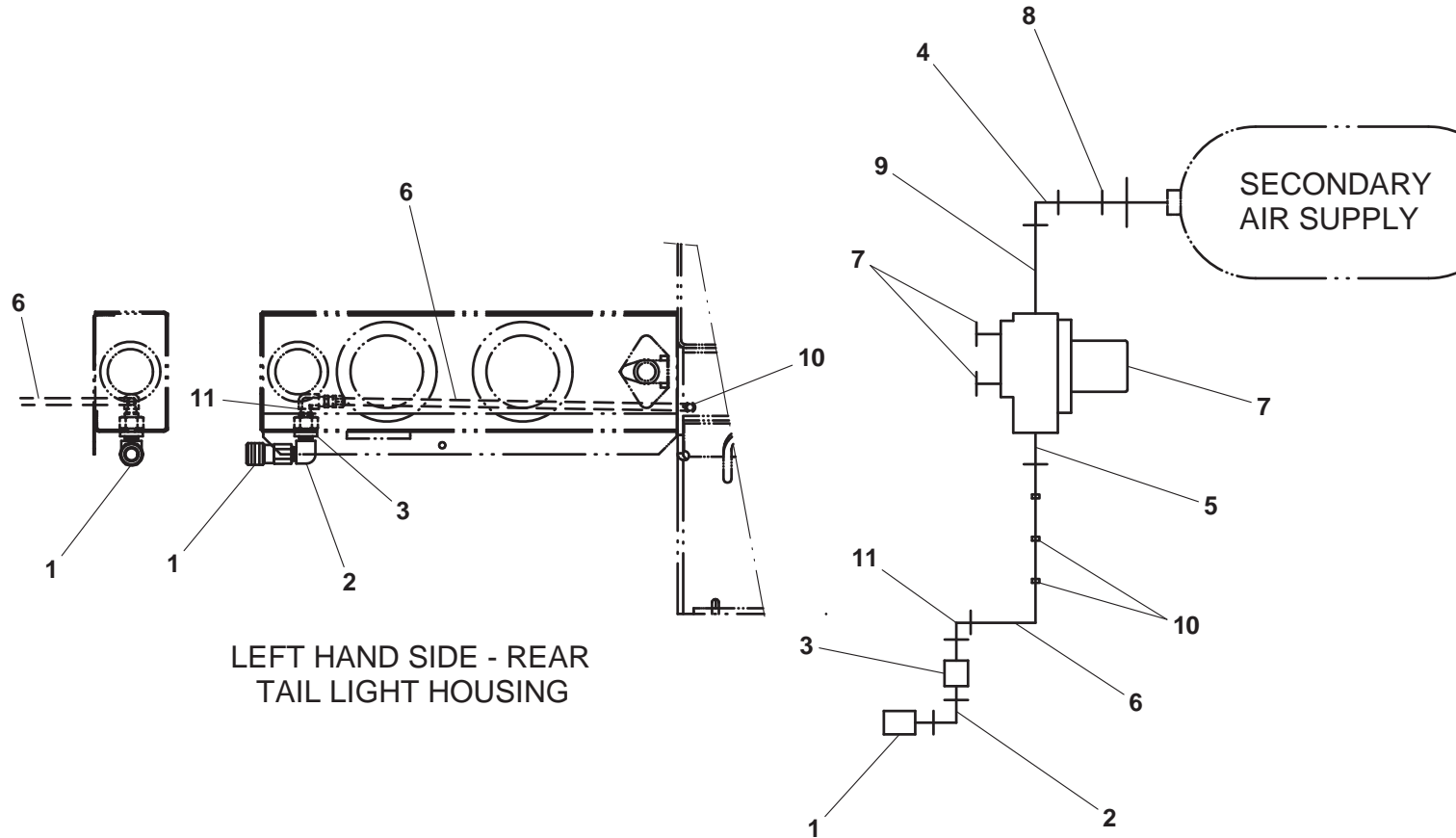

**JUMP START KIT**

ITEM	PART NO.	DESCRIPTION	QTY
1	7002000386	Jump Start Plug (IHC & Other)	1
	7002000385	Jump Start Plug (Ford & GM)	
2	4178000372	Bracket (Ford & Other)	1
	4178000202	Bracket (GM)	
3	4178000203	Bracket (GM)	1
	4706003210	Plate (Other)	
4	7110140605	Capscrew, 0.25"-20NC x 0.75" (Ford, GM & Other)	1
5	7950140161	Flatwasher, 0.25" ID (Ford & Other)	1
	7950140161	Flatwasher, 0.25" ID (IHC)	2
	7950140161	Flatwasher, 0.25" ID (GM)	3
6	7660142600	Locknut, 0.25"-20NC (Ford, GM & Other)	1
	7660142600	Locknut, 0.25"-20NC (IHC)	2
7	7115151064	Carriage Bolt, 0.31"-18NC x 1.25" (Other)	2
8	7950150161	Flatwasher, 0.31" ID (Other)	2
9	7660152601	Locknut, 0.31"-18NC (Other)	2
10	7115141450	Capscrew, 0.25"-20NC x 1.75" (IHC)	1
11	7115141650	Capscrew, 0.25"-20NC x 2.00" (IHC)	1
12	7660140000	Hex Nut, 0.25"-20NC (IHC)	1
	7660140000	Hex Nut, 0.25"-20NC (GM)	2
13	7111140850	Capscrew, 0.25"-20NC x 1.00" (GM)	2
14	7115181050	Capscrew, 0.50"-13NC x 1.25" (GM)	1
15	7950180153	Flatwasher, 0.50" ID (GM)	1
16	7660180000	Hex Nut, 0.50"-13NC (GM)	1



# JUMP START KIT

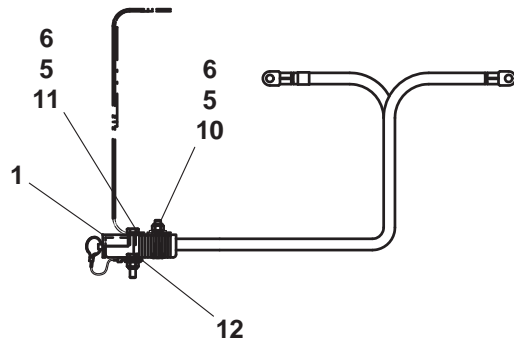

IHC FRONT BUMPER

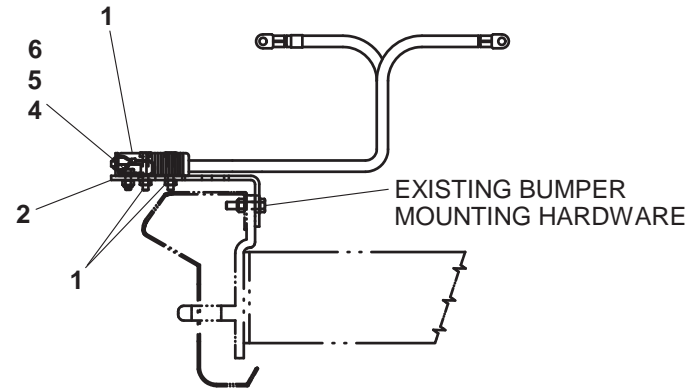

FORD FRONT BUMPER

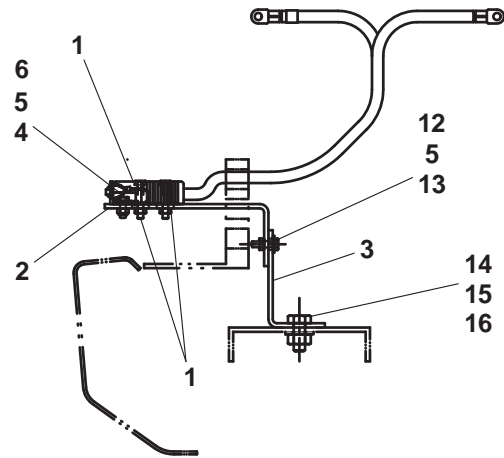

CHEVY FRONT BUMPER

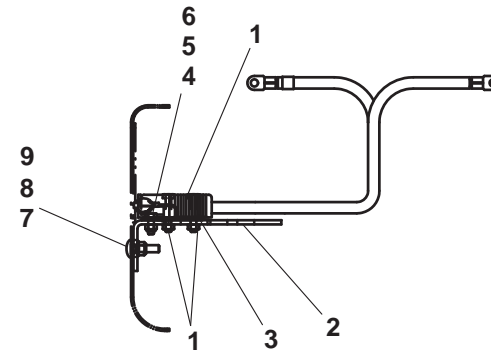

ALL OTHER FRONT BUMPERS

**FOLDING DECK LADDER**

ITEM	PART NO.	DESCRIPTION	QTY
1	3178000555	Bracket Weld	1
2	3002000009	Ladder Top Weld	1
3	3002000008	Ladder Bottom Weld	1
4	7114181418	Capscrew, 0.50"-13NC x 1.75"	4
5	7950180141	Flatwasher, 0.50" ID	12
6	7660182601	Locknut, 0.50"-13NC	4
7	7115180606	Shoulder Bolt, 0.50"-13NC x 0.75"	2
8	7950160161	Flatwasher, 0.38" ID	2
9	7660162601	Locknut, 0.38"-16NC	2

# FOLDING DECK LADDER

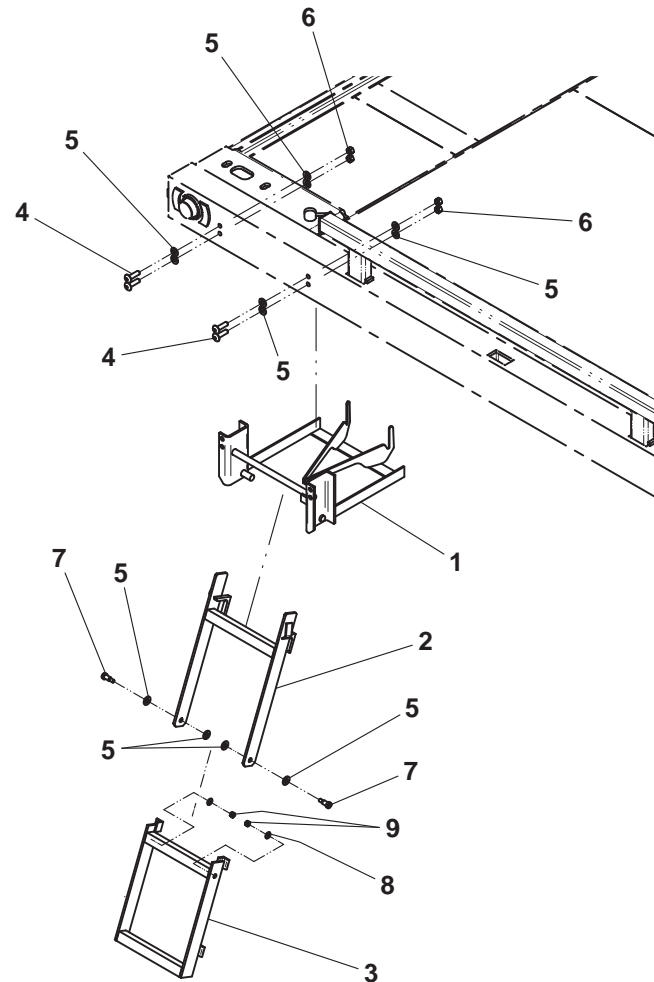

**CHAINS AND STRAPS**

ITEM	PART NO.	DESCRIPTION	QTY
1	7262000022*	Winch V-Chain	1
2	7262000056*	Front Tie-Down Chain	2
3	7894000019*	Rear Tie-Down Strap	2
4	7894000020*	Rear Tie Down Ratchet	2
5	7262000040	Wheel Lift Chain	2
6	7894000034+	Wheel Lift Tire Strap	2
7	7262000010	Towbar Chain	2
8	7894000058^	Tire Strap (hydraulic grid)	1
9	7894000059^	Choker (hydraulic grid)	1
10	7894000028^	Ratchet (hydraulic grid)	1
11	7561000024^	Forged Hook (hydraulic grid)	1
12	7115181664	Carriage Bolt, 0.50"-13NC x 2.00"	2
13	7660180001	Nut, 0.50"-13NC	2
14	7660182601	Locknut, 0.50"-13NC	2
15	5525000752	Magnetic Tow Lights	1
16	7894000073	8 Point Tie-Down Kit	1

\* also available in Deck Chain / Tie-Down Kit, P/N 7577000208

^ also available in Hydraulic Grid Wheel Lift Tie-Down Kit, P/N 7577000376

+ also available in Wheel Lift Tie-Down Strap and Ratchet Kit, P/N 7577000242

# CHAINS AND STRAPS

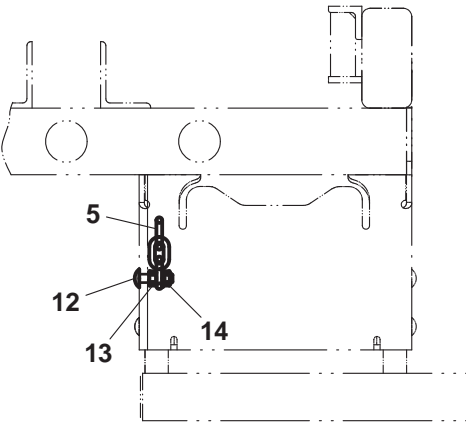
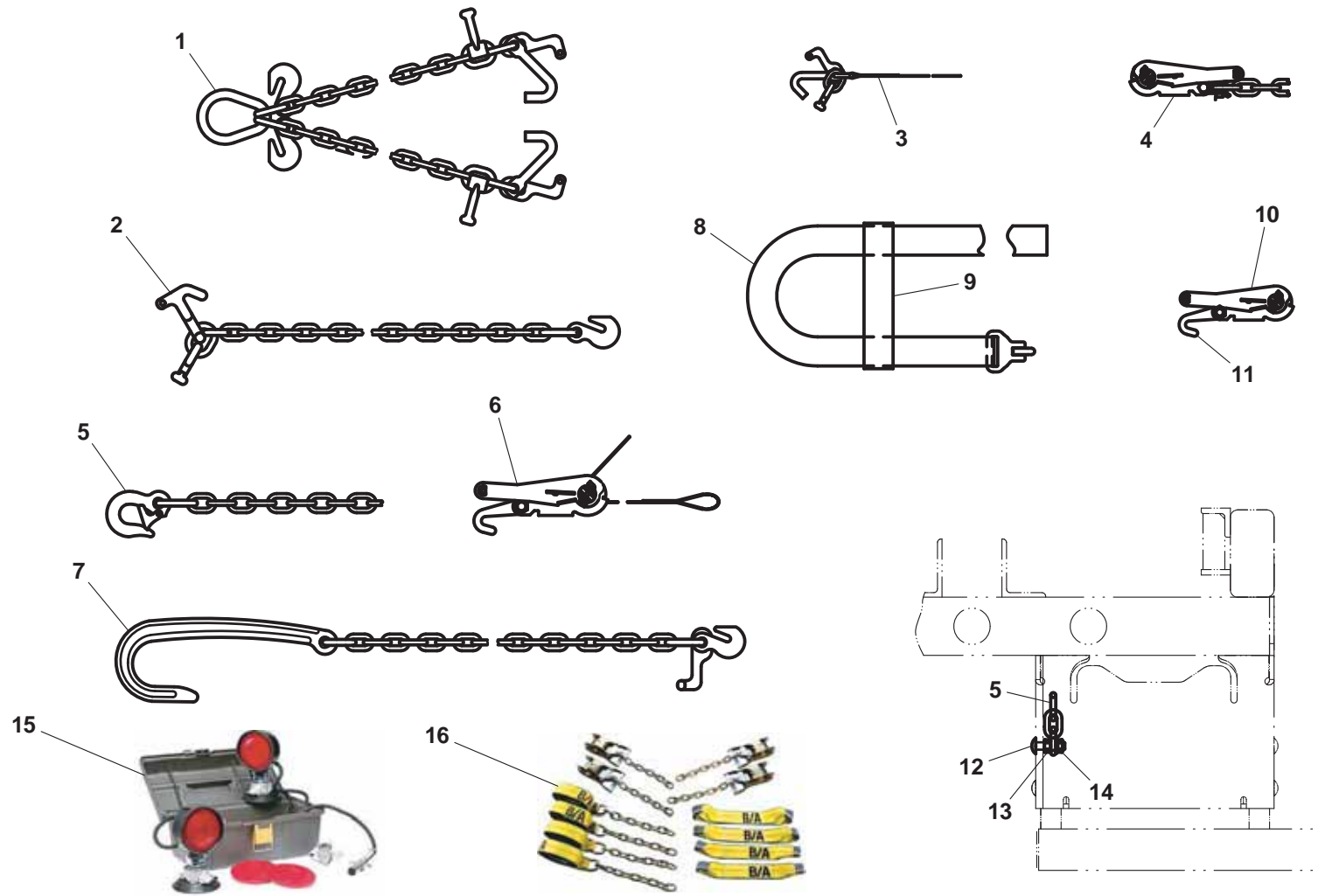

CHAIN BOX AT REAR OF SUBFRAME

**TOWING SAFETY TOOLS**

ITEM	PART NO.	DESCRIPTION	QTY
1	9002000141*	Wheel Chock	1
2	9900000001*	Shovel	1
3	9900000006*	Maul Axe	1
4	9900000004*	Floor Jack -2.5 Ton	1
5	9900000005*	Floor Jack Handle	1
6	9900000007*	Lug Wrench -Metric	1
7	9900000008*	Lug Wrench -SAE	1
8	9900000002*	Broom Head	1
9	9900000003*	Broom Handle	1
10	9900000009*	Pry Bar	1
11	9611000001*	Wood Crossbeam -4'	1
12	9611000002*	Wood Crossbeam -5'	1
13	9002000142*	Trash Can -4 Gallon	2
14	9890000002*	Air Tank -5 Gallon	1
15	9002000143*	Flare -30 Minute	6
16	9900000010*	Bolt Cutters -24"	1
17	9002000144*	Triangle Flare Kit	1
18	9002000145*	First Aid Kit -25 Person	1
19	9900000008*	Snatch Block w/ Hook	1

\* also available in Towing Safety Tools Kit, P/N 3577000120

# TOWING SAFETY TOOLS

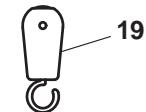
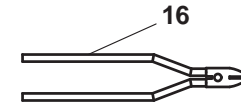
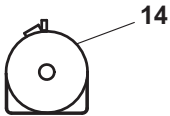
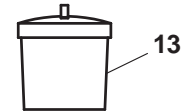
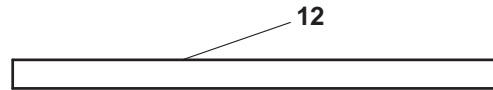
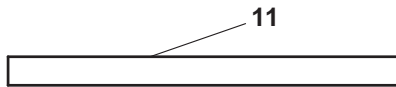
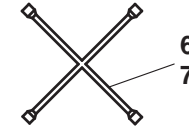
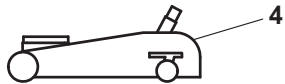
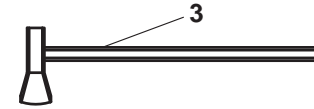
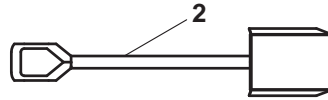
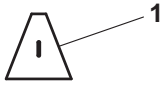

**DECALS**

ITEM	PART NO.	DESCRIPTION	QTY
1	7330000167	Serial Number Tag	1
2	7330000338	Subframe / Patent Tag	1
3	7330000502	Decal - Slide Pad / Pivot Joint	1
4	7330000159	STAR Placard	1
5	7330000275	Decal - Operator's Pre-Checklist	1
6	7330000242	Decal - Free Spool (bolt-on headboard)	1
	7330000495	Decal - Free Spool (stationary headboard)	
7	7330000478	Decal - Lubrication Chart	1
8	7330000012	Decal - Winch	1
9	7330000433	Jerr-Dan Nameplate	3
10	7330000143	Decal - Made In The USA	1
11	7330000044	Decal - Align Arrow, Red	2
	7330000045	Decal - Align Arrow, White	
12	7330000272	Decal - Oil Level	1
13	7330000330	Decal - Cable Track	1
14	7330000139	Decal - Checklist Reminder	1
15	7330000684	Decal - Safety	1
16	7330000683	Decal - Safety	2
17	7330000060	Decal - Wheel Lift Hitch	1
18	7330000036	Secure Vehicle	2
19	7330000391	Decal - Tow Boom Configuration	1
20	7330000274	Decal - Overloading Tow Option	1
21	7330000599	Decal - Pinch Point	3
22	9330740009	Decal Kit - Muncie PTO	1
23	7759000004	Pop Rivet	12
24	7330000675	Decal - Air Free Spool Control, LH	1
25	7330000676	Decal - Air Free Spool Control, RH	1
26	7330000176	Decal - Air Suspension	1
27	7330000698	Decal - Control Switch (F550 only)	1
28	7330000700	Decal - PTO Operation (LCF & CF600 only)	1
29	7330000385	Decal - T37 Grids	2



# DECALS

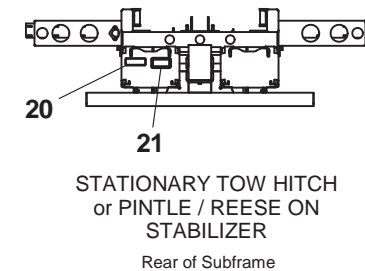
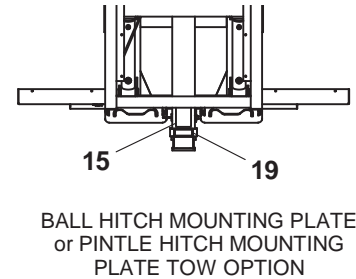
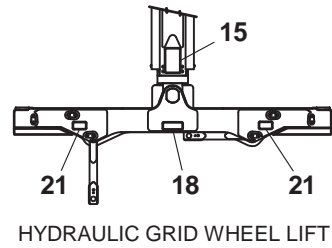
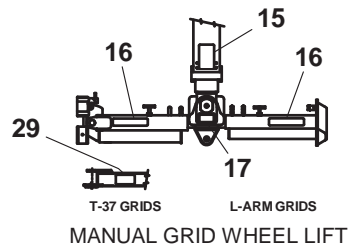
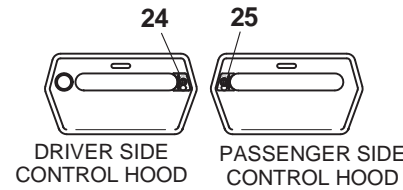
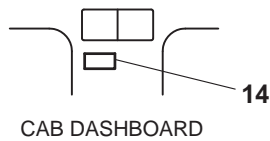
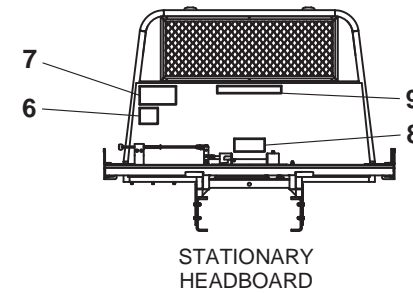
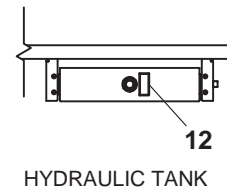
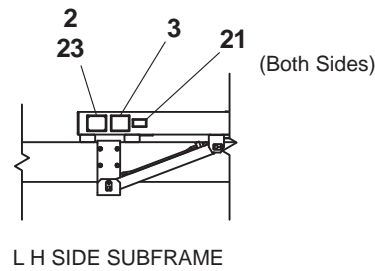
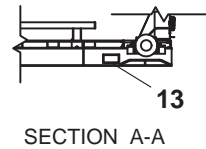
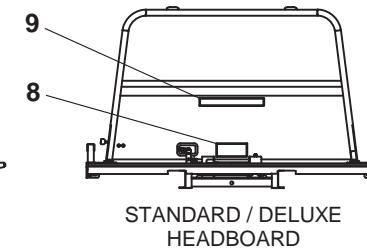
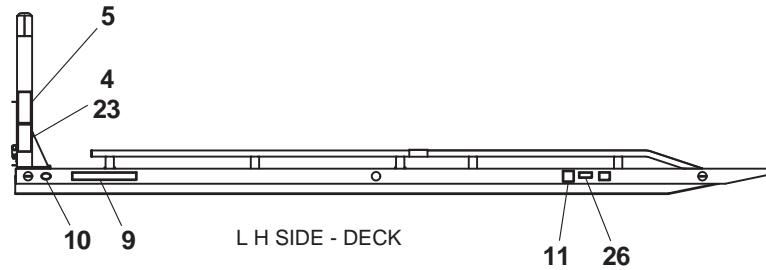
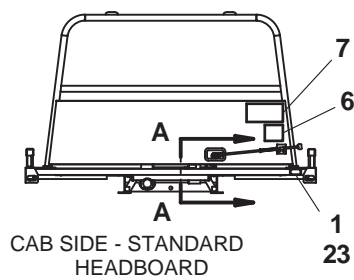

Items #22, Decal Kit; #27, Decal - Control Switch; and #28, Decal - PTO Operation, not shown

**ACCESSORY EQUIPMENT**

ITEM	PART NO.	DESCRIPTION	QTY
1	7002000449	Magnetic Tow Lights	1
2	7002000404	Fire Extinguisher	1
3	7002000448	Wheel Chock	1
4	7002000285	Reflective Triangles	1
5	7002000451	Load Binder - 0.38" Chain	1
6	Not Required		
7	7002000521	Remote Control Transmitter Holder	1
8	7002000447	Valve Stem Extension Kit	1
9	7002000503	Air Compressor with Hose Reel	1
10	7443000111	Elbow	1
11	7115161050	Capscrew, 0.38"-16NC x 1.25"	4
12	7950150161	Flatwasher, 0.31" ID	4
13	7660162601	Locknut, 0.38"-16NC	4
14	7115181050	Capscrew, 0.50"-13NC x 1.25"	4
15	7950180153	Flatwasher, 0.50" ID	8
16	7660182601	Locknut, 0.50"-13NC	4

# ACCESSORY EQUIPMENT

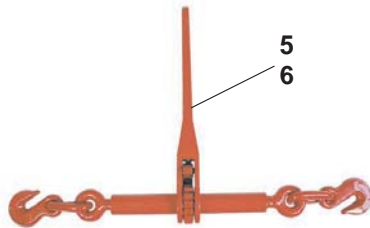
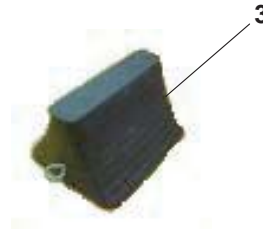

5  
6

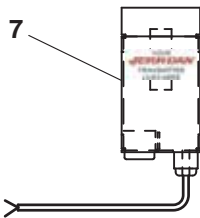

7  
LOCATED INSIDE CAB

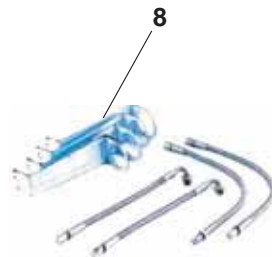

8

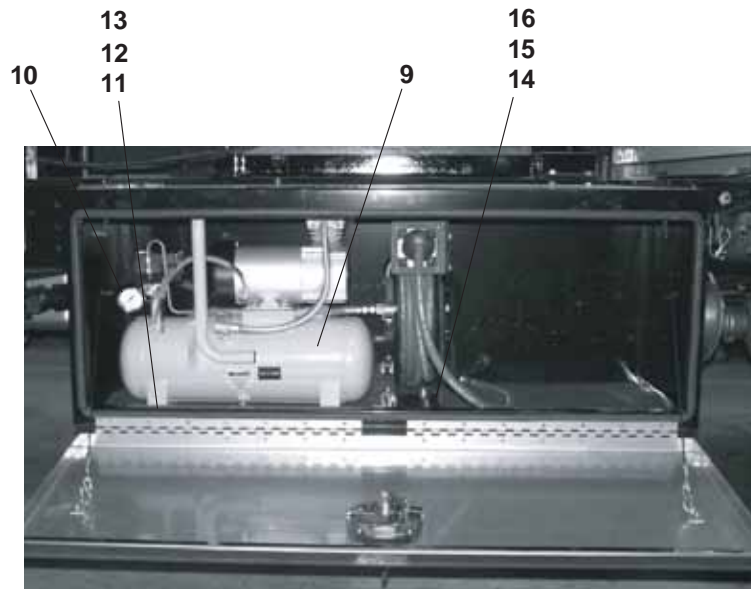

10  
11  
12  
13  
14  
15  
16  
9  
SHOWN MOUNTED INSIDE 48" TOOLBOX

# HYDRAULIC SCHEMATIC

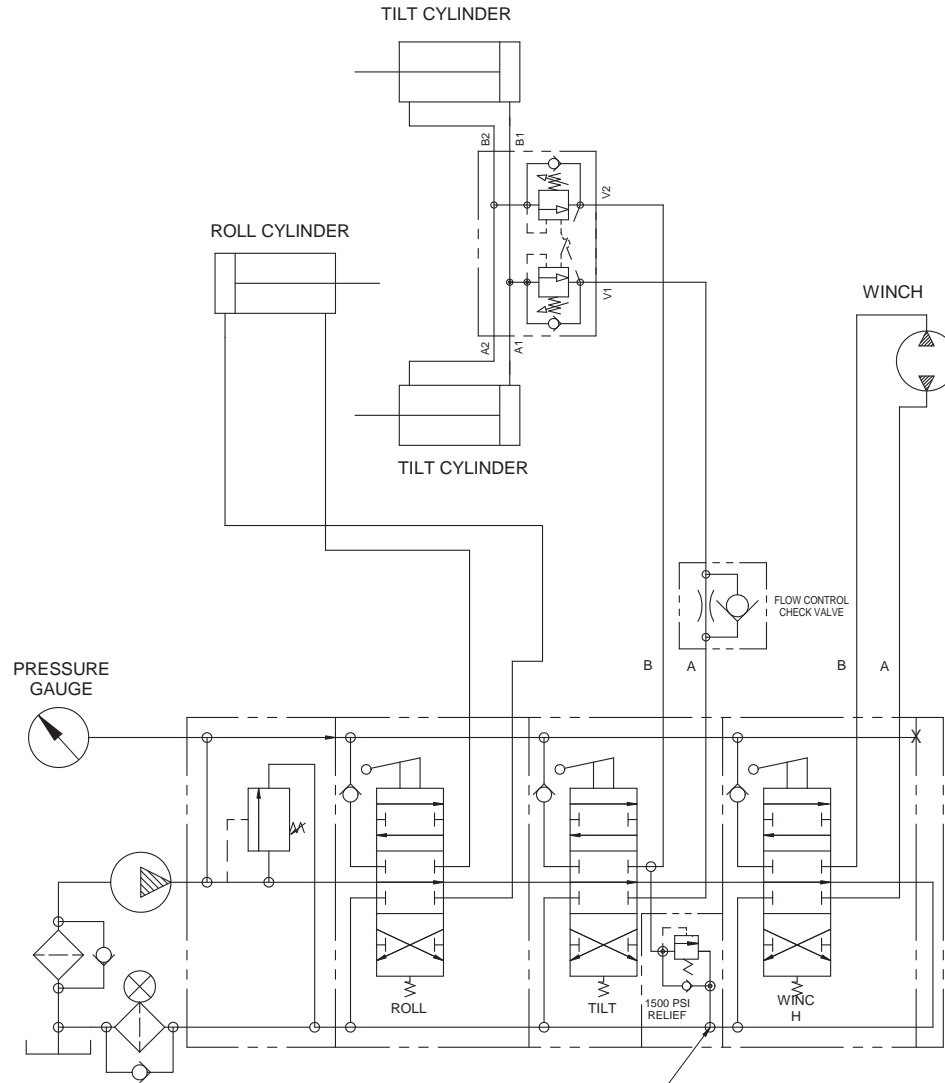

TILT RELIEF ON  
UNITS WITH INBOARD  
TILT CYLINDERS ONLY

3 Bank Control Valve - No Tow Option

# HYDRAULIC SCHEMATIC

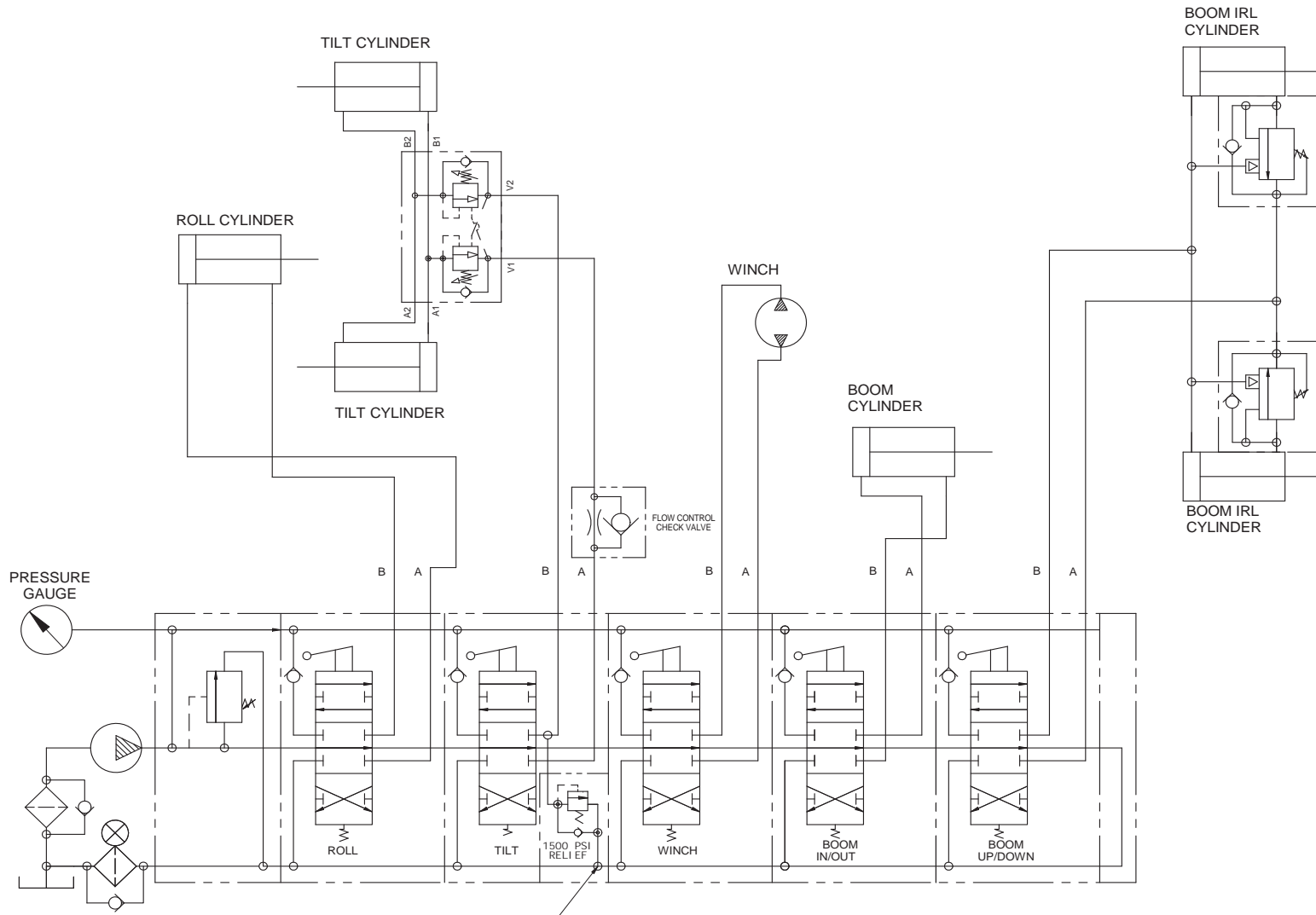

5 Bank Control Valve - IRL Tow Option

TILT RELIEF ON  
UNITS WITH INBOARD  
TILT CYLINDERS ONLY

# HYDRAULIC SCHEMATIC

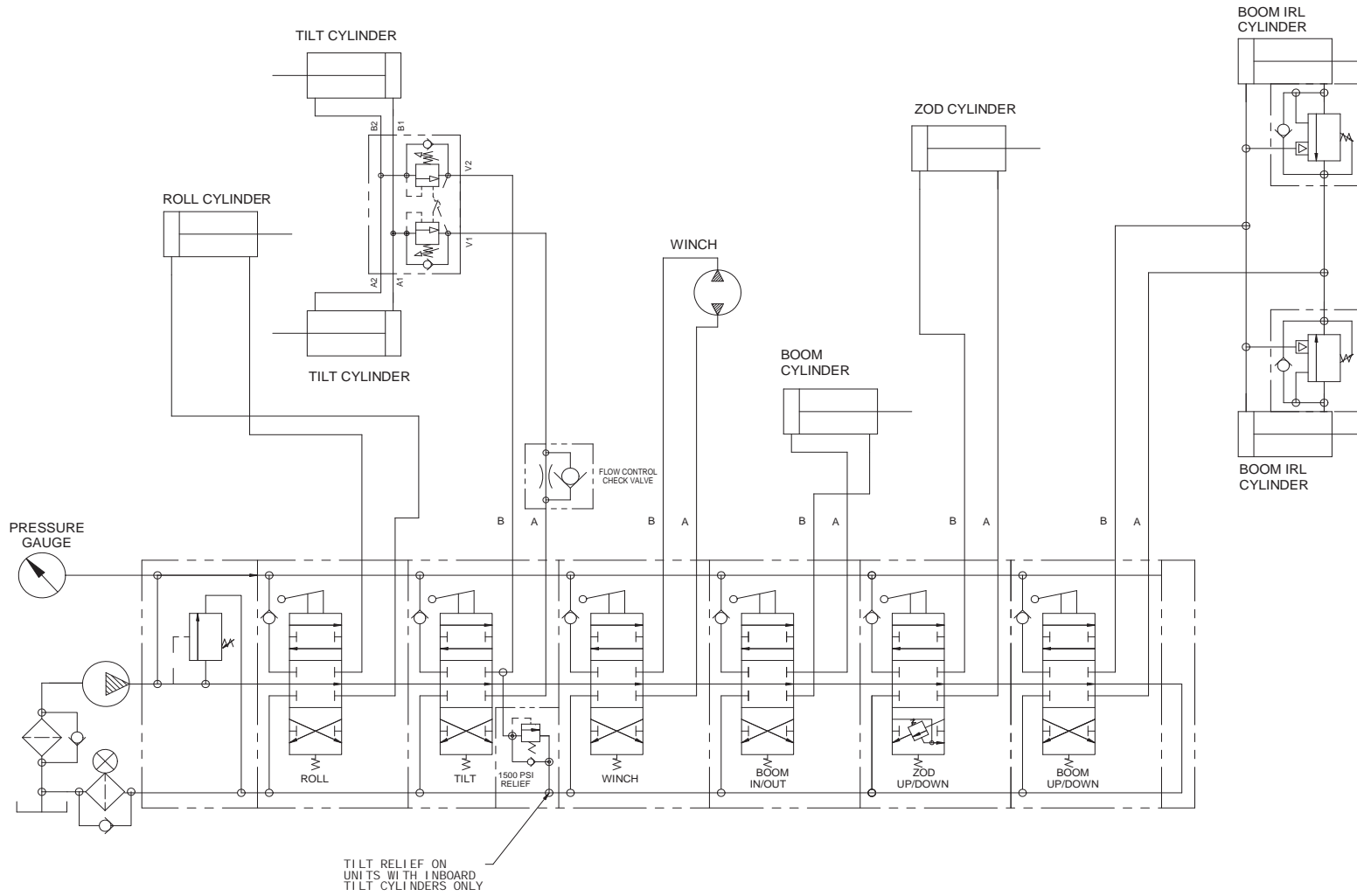

6 Bank Control Valve - ZOD Tow Option

# HYDRAULIC SCHEMATIC

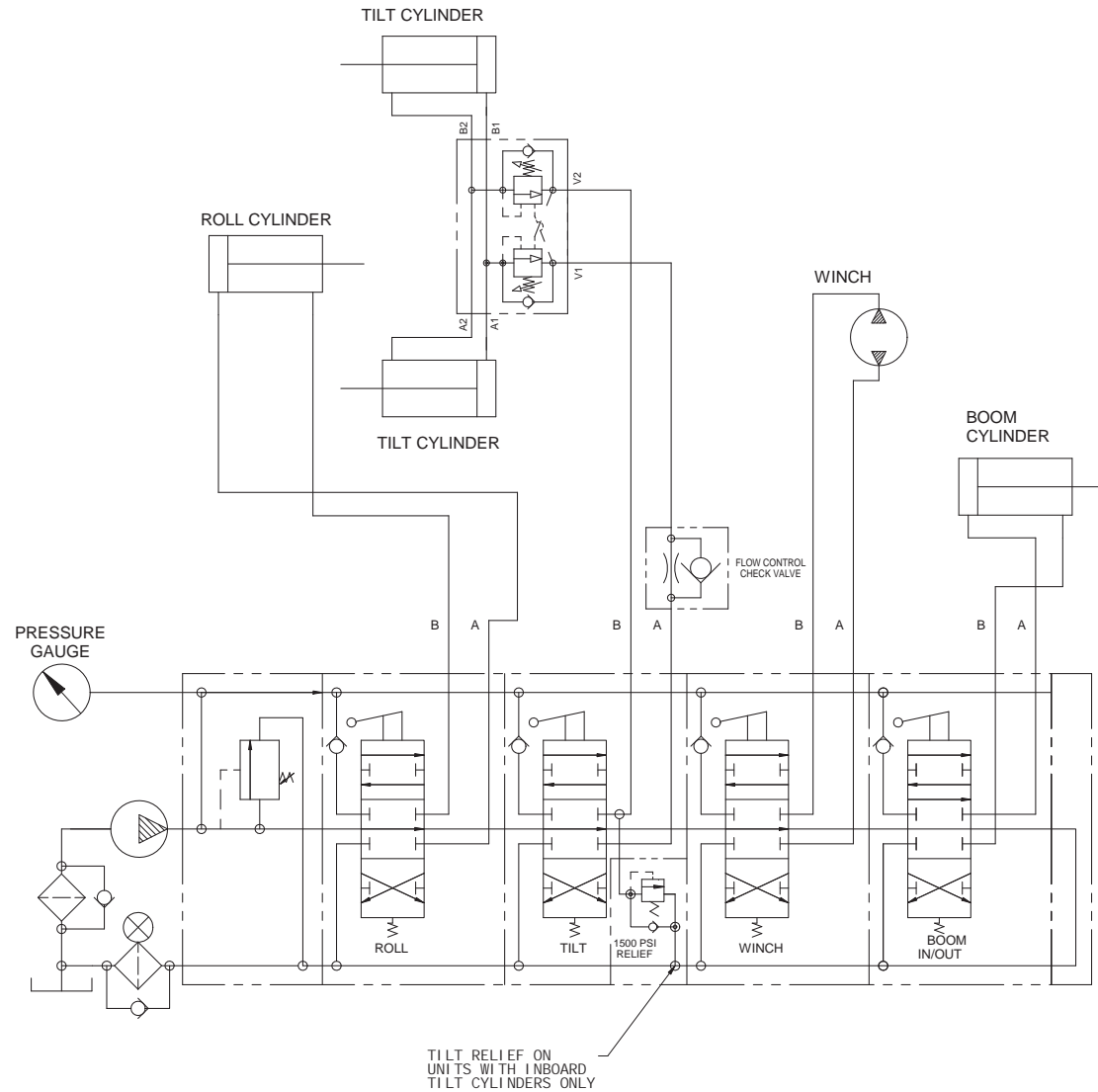

4 Bank Control Valve - Hydraulic Extended Boom Tow Option

# HYDRAULIC SCHEMATIC

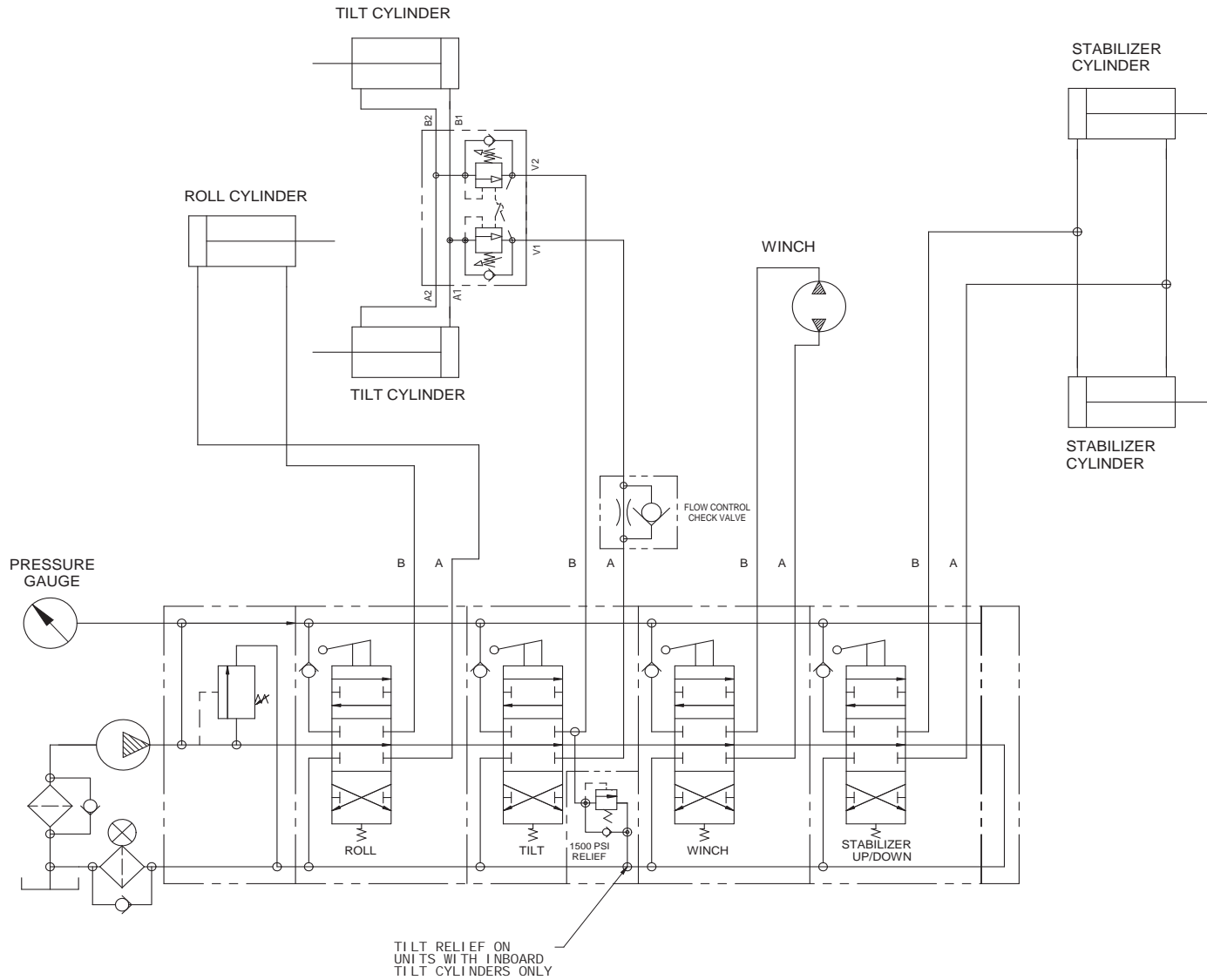

4 Bank Control Valve - Stabilizer Option



# HYDRAULIC SCHEMATIC

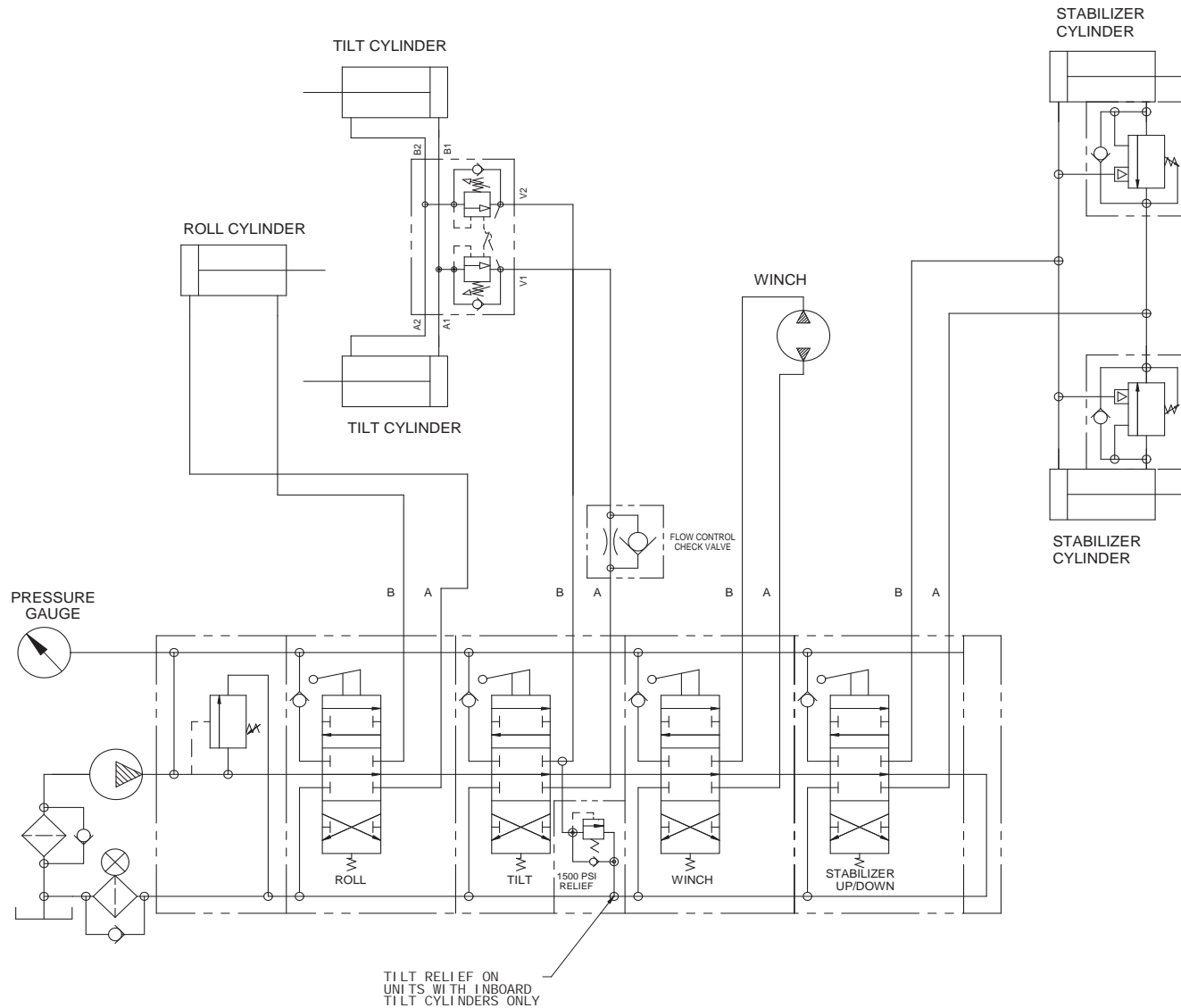

4 Bank Control Valve - Stabilizer with Tow Option

# HYDRAULIC SCHEMATIC

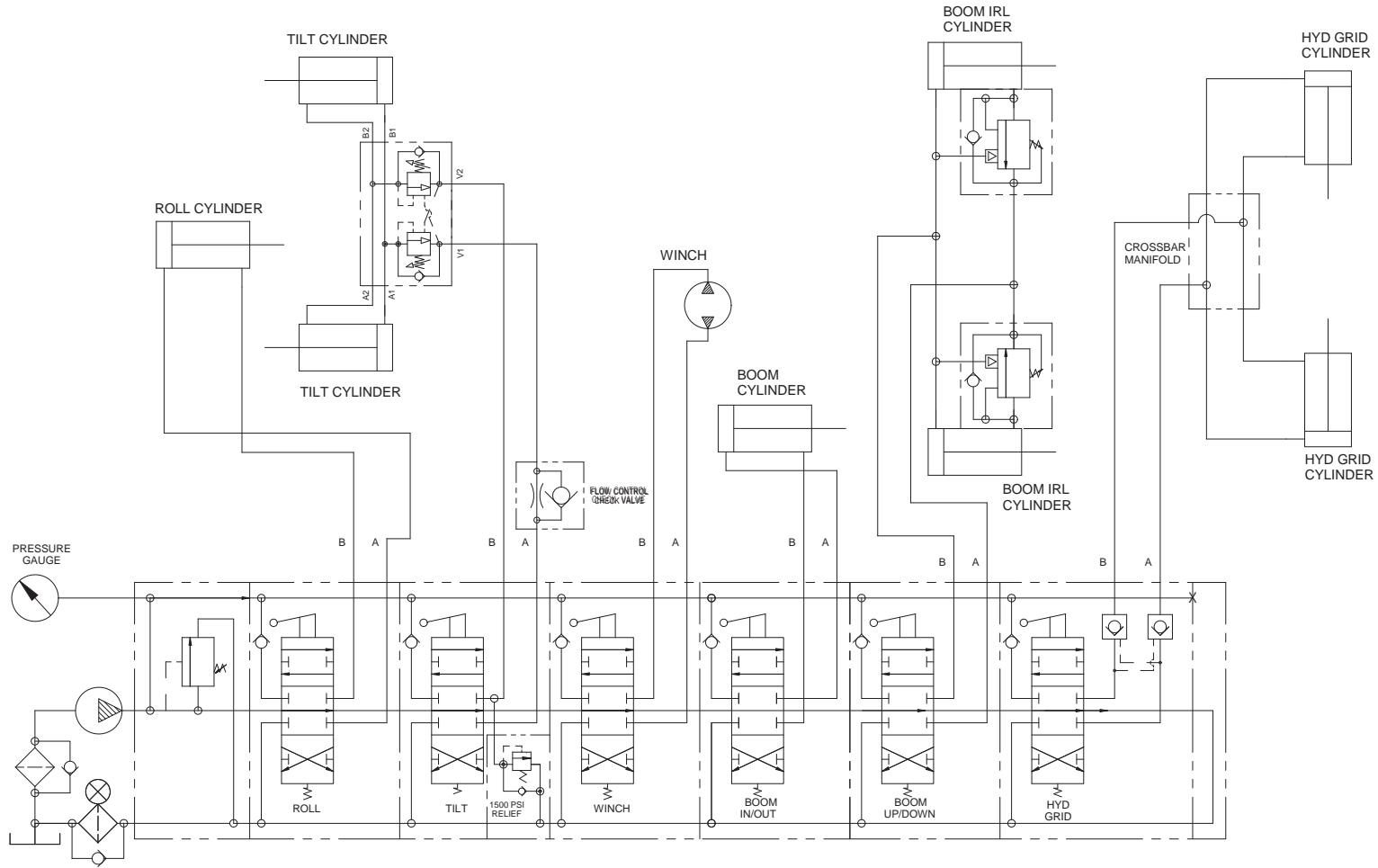

7 Bank Control Valve - IRL Wheel Lift w/ Hydraulic Grids

# HYDRAULIC SCHEMATIC

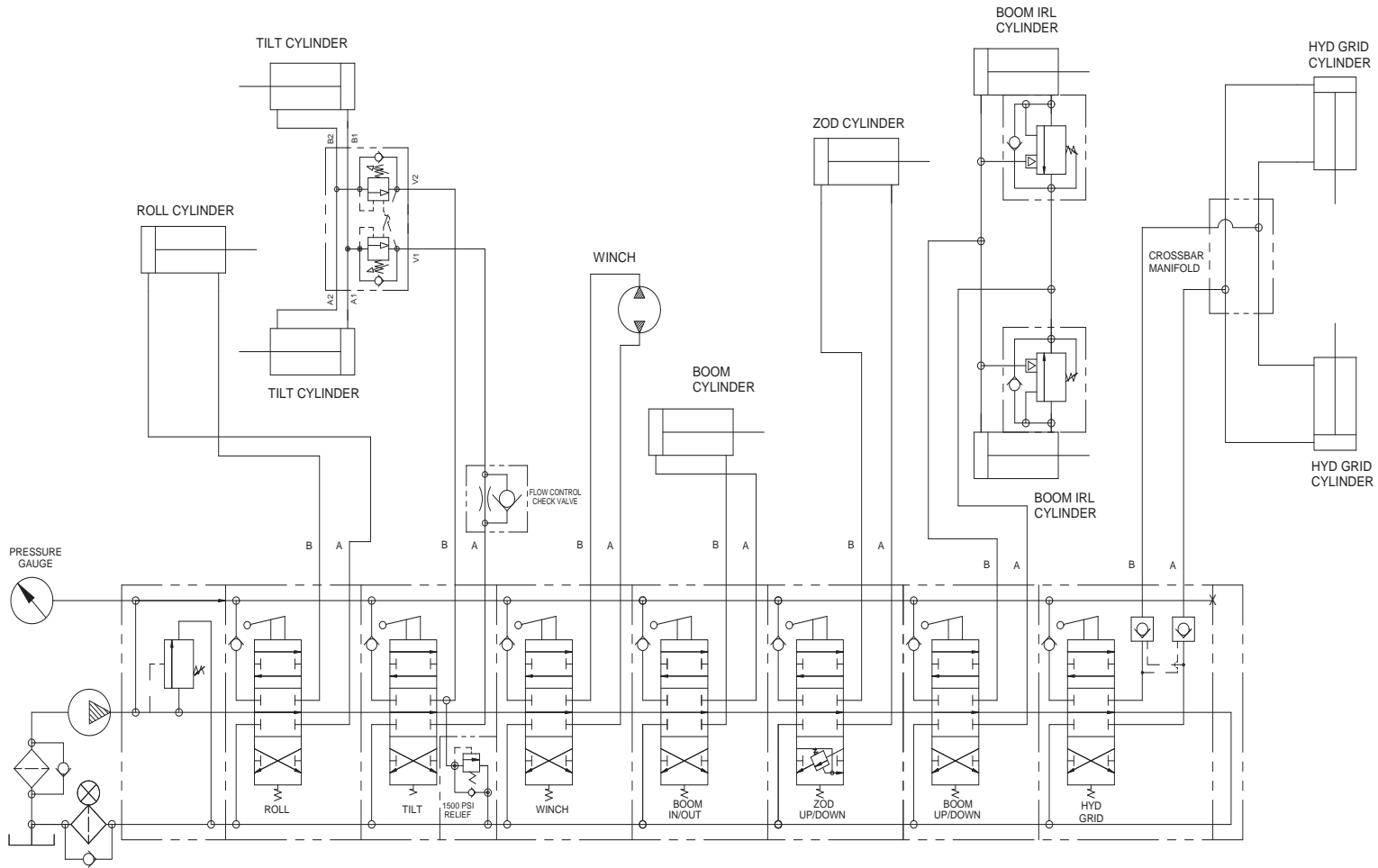

7 Bank Control Valve - ZOD Wheel Lift w/ Hydraulic Grids

**THIS PAGE INTENTIONALLY LEFT BLANK**

# ELECTRICAL SCHEMATIC

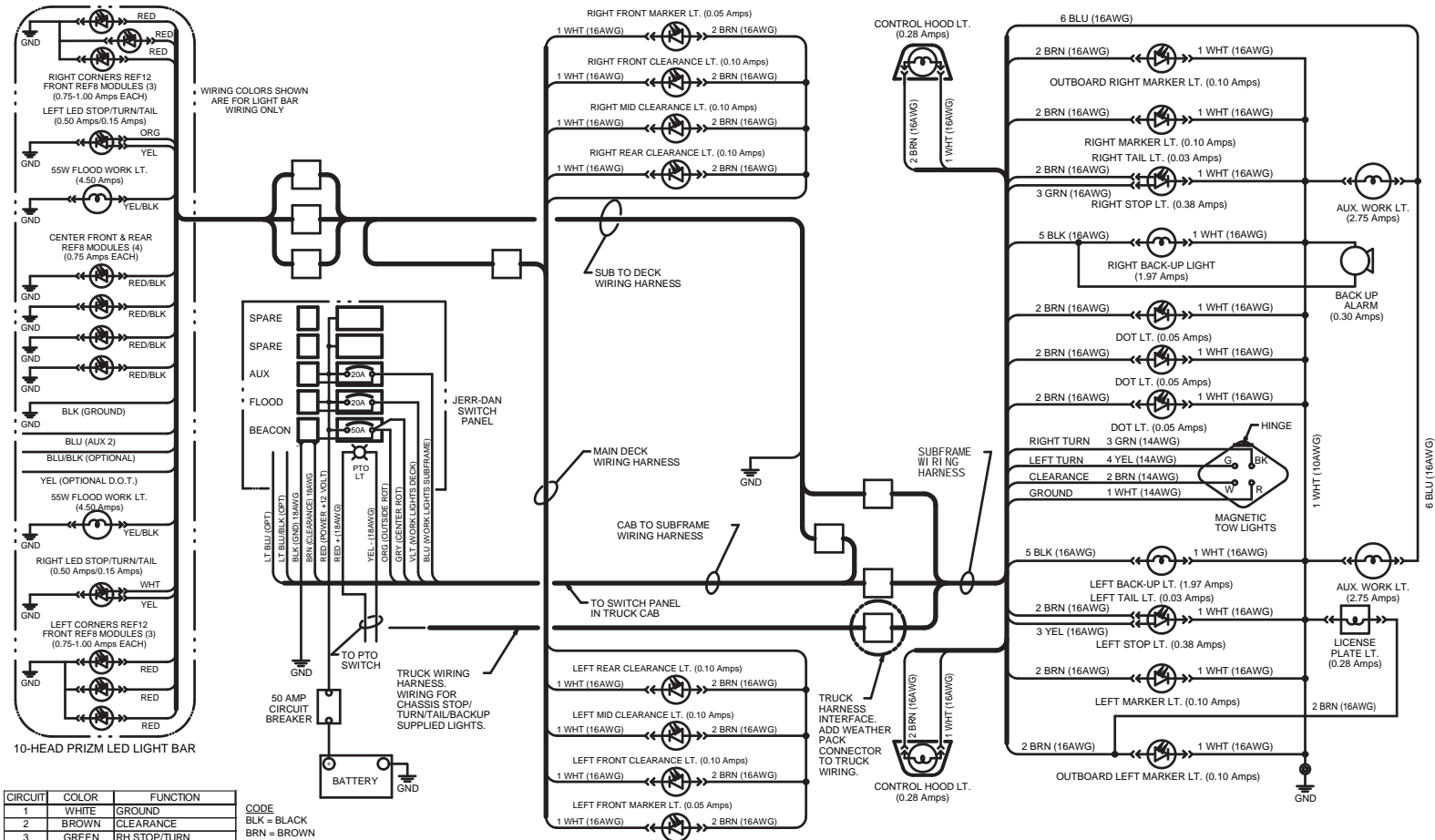

CIRCUIT	COLOR	FUNCTION
1	WHITE	GROUND
2	BROWN	CLEARANCE
3	GREEN	RH STOP/TURN
4	YELLOW	LH STOP/TURN
5	BLACK	BACK-UP
6	BLUE	WORK LIGHTS (SUBFR)
7	VIOLET	WORK LIGHTS (LT-BAR)
8	GRAY	BEACON (ROTATORS)
9	ORANGE	AUX 1 (FLASHER)
10	LT BLUE/BLACK	OPTION
11	LT BLUE	AUX 2

CODE  
 BLK = BLACK  
 BRN = BROWN  
 BLU = BLUE  
 GRN = GREEN  
 RED = RED  
 YEL = YELLOW  
 LT = LIGHT  
 ORG = ORANGE  
 VLT = VIOLET  
 WHT = WHITE

**THIS PAGE INTENTIONALLY LEFT BLANK**