

MEDIUM DUTY CARRIER PARTS MANUAL

JERR-DAN[®]

An Oshkosh Corporation Company

1080 Hykes Road
Greencastle, PA 17225
Phone (717) 597-7111
www.jerr-dan.com

5-376-000090
Rev 1 - March 01, 2007

© 2007 Jerr-Dan Corporation. All Rights Reserved.

This manual covers the following Jerr-Dan Models:

_75T2B - 7.5 Ton Steel B.I.C.

_75TRB - 7.5 Ton Steel B.I.C. Transporter

Jerr-Dan Corporation strives to provide information that is accurate, complete and useful. Descriptions and illustrative material contained within this manual are as accurate as known at the time of publication and are subject to change, without notice, as a result of continuous product improvements. Jerr-Dan reserves the right to amend the information in this document at any time without prior notice.

Information contained in this manual reflects how this vehicle was built at the factory. Modifications or additions by the distributor or owner are not reflected in this manual.

This parts manual does not include service parts information for the commercial chassis (IHC, Ford, GM, etc.). This parts information is provided by the chassis manufacturer.

When ordering parts, please refer to your unit's Sales Order Number, Serial Number and Model Number. This information can be found on the aluminum tag riveted to the front left corner of the deck as shown below:

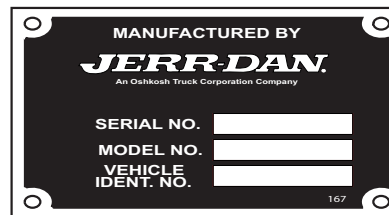

Additional or replacement manuals can be ordered by calling Jerr-Dan Parts at 717-597-7111. Price and availability will be quoted at time of the request.

Please report comments and/or errors by contacting Jerr-Dan Corporation's Technical Publications Department by e-mail at technicalpublications@jerr-dan.com or by FAX on 717-593-2362.

Manufactured under one or more of the following patents: 5,044,865; 5,575,606; 5,697,741; 5,951,235; 6,231,294 B1; 6,336,783 B1; and 6,447,239 B2 with other Patents Pending.

Jerr-Dan and the Jerr-Dan logo are registered trademarks of Jerr-Dan Corporation, Greencastle, PA USA.

The material in this document is confidential and the property of Jerr-Dan Corporation. No part of this document may be photocopied, reproduced or translated to another language without the express written consent of Jerr-Dan Corporation.

INDEX

DESCRIPTION	PAGE	DESCRIPTION	PAGE
Deck - Steel B.I.C. (_75T2B)	4 - 5	Hydraulic Rear Dock Stabilizer	92 - 93
Deck - Steel B.I.C. Transporter (_75TRB)	6 - 7	Stabilizer w/ Reese Hitch Receiver	94 - 95
Standard Headboard & Remote Winch Free Spool (10,000 lb Worm Gear Winch)	8 - 9	Stabilizer w/ Manual Extend Pintle Hitch Mounting Plate	96 - 97
Deluxe Headboard & Remote Winch Free Spool (10,000 lb Worm Gear Winch)	10 - 11	Stabilizer w/ Hydraulic Extend Pintle Hitch Mounting Plate	98 - 99
Stationary Headboard & Remote Winch Free Spool (10,000 lb Worm Gear Winch)	12 - 13	Stabilizer w/ Hydraulic Extend Wheel Lift	100 - 101
Remote Winch Free Spool (12,000 lb Worm Gear Winch)	14 - 15	Ball Hitch Mounting Plate - IRL	102 - 103
Worm Gear Winch (10,000 lb)	16 - 17	Ball Hitch Mounting Plate - Hydraulic Extend	104 - 105
Worm Gear Winch (12,000 lb)	18 - 19	Ball Hitch Mounting Plate - Manual Extend	106 - 107
Worm Gear Winch Cable Roller / Tensioner Plate	20 - 21	Pintle Hitch Mounting Plate - IRL	108 - 109
Subframe - 22' & 24' Decks	22 - 23	Pintle Hitch Mounting Plate - Hydraulic Extend	110 - 111
Subframe - 26' & 28' Decks	24 - 25	Pintle Hitch Mounting Plate - Manual Extend	112 - 113
Hold Down - 22' & 24' Decks	26 - 27	Towbar - IRL	114 - 115
Hold Down - 26' & 28' Decks	28 - 29	Towbar - Hydraulic Extend	116 - 117
Slide Pad	30 - 31	Roll Cylinder Assembly	118 - 119
Mud Flap	32 - 33	Tilt Cylinder Assembly	120 - 121
Final Assembly	34 - 35	Wheel Lift Extend Cylinder Assembly	122 - 123
Hydraulic Reservoir and Toolbox / Basket	36 - 39	IRL Cylinder Assembly	124 - 125
Toolbox	40 - 41	ZOD Cylinder Assembly	126 - 127
Toolbox Shelf	42 - 43	Stabilizer Cylinder Assembly	128 - 129
Toolbox Light	44 - 45	Hydraulic Tow Option Extend Cylinder Assembly	130 - 131
Dual Controls - 3 Bank	46 - 47	Hydraulic Tow Option Extend Cylinder Assembly for Stabilizer	132 - 133
Dual Controls - 4 Bank	48 - 49	Lightbars	134 - 135
Dual Controls - 5 Bank	50 - 51	Switch Panels	136 - 137
Dual Controls - 6 Bank	52 - 53	Work Lights	138 - 139
Hydraulic Components - Standard	54 - 55	Bolt-On D-Rings	140 - 141
Hydraulic Components - Standard (Hose Track)	56 - 57	Remote Control Operation(s)	142 - 143
Hydraulic Components - Hose Routing / Mounting	58 - 59	Remote Throttle Control	144 - 145
Hydraulic Components - IRL Wheel Lift w/ Man Grids or IRL Ball / Pintle Hitch Mtg Plt ...	60 - 61	Glad Hands and 7- Way Connector	146 - 147
Hydraulic Components - ZOD Wheel Lift w/ Manual Grids	62 - 63	Air Supply Disconnect	148 - 149
Hydraulic Components - Stabilizer	64 - 65	Jump Start Kit	150 - 151
Hydraulic Components - Stabilizer w/ Reese Hitch Receiver or Pintle Hitch Mtg Plate ...	66 - 67	Folding Deck Ladder	152 - 153
Hydraulic Components - Stabilizer w/ Hydraulic Extend Pintle Hitch Mounting Plate	68 - 69	Chains and Straps	154 - 155
Hydraulic Components - Stabilizer w/ IRL Wheel Lift	70 - 71	Decals	156 - 157
Hydraulic Components - IRL Towbar	72 - 73	Hydraulic Schematic	158 - 164
Hydraulic Components - Hydraulic Extend Tow Option	74 - 75	Electrical Schematic	165
Electrical Components - Standard w/ Bolt-On Headboard (22' & 24' Decks)	76 - 77		
Electrical Components - Standard w/ Bolt-On Headboard (26' & 28' Decks)	78 - 79		
Electrical Components - Standard w/ Stationary Headboard	80 - 81		
Electrical Components - Optional	82 - 83		
IRL Wheel Lift	84 - 85		
ZOD Wheel Lift	86 - 87		
Manual L-Arm Wheel Lift Grid	88 - 89		
Manual T37 Pivoting Wheel Lift Grid	90 - 91		

DECK - STEEL B.I.C. (_75T2B)

ITEM	PART NO.	DESCRIPTION	QTY	ITEM	PART NO.	DESCRIPTION	QTY
1	3097000537	22' Deck - 96" wide, 12" X-mem spacing	1			<i>Standard Steel Tubular Removable Rails:</i>	
	3097000541	22' Deck - 96" wide, 8" X-mem spacing					
	3097000545	22' Deck - 102" wide, 12" X-mem spacing		9	3729000126	Steel Rail, LH Front	1
	3097000549	22' Deck - 102" wide, 8" X-mem spacing		10	3729000126	Steel Rail, RH Front	1
	3097000538	24' Deck - 96" wide, 12" X-mem spacing		11	3729000127	Steel Rail, LH Rear (22' deck)	1
	3097000542	24' Deck - 96" wide, 8" X-mem spacing			3729000129	Steel Rail, LH Rear (24' deck)	
	3097000546	24' Deck - 102" wide, 12" X-mem spacing		12	3729000128	Steel Rail, RH Rear (22' deck)	1
	3097000550	24' Deck - 102" wide, 8" X-mem spacing			3729000130	Steel Rail, RH Rear (24' deck)	
	3097000574	26' Deck - 96" wide, 12" X-mem spacing		13	7120000005	Capscrew, 0.50"-13NC x 2.50"	12
	3097000578	26' Deck - 96" wide, 8" X-mem spacing		14	7701000033	End Cap	4
	3097000576	26' Deck - 102" wide, 12" X-mem spacing				<i>Optional Aluminum Removable Rails:</i>	
	3097000580	26' Deck - 102" wide, 8" X-mem spacing					
	3097000575	28' Deck - 96" wide, 12" X-mem spacing					
	3097000579	28' Deck - 96" wide, 8" X-mem spacing		9	3017000084	Aluminum Rail, LH Front	1
	3097000577	28' Deck - 102" wide, 12" X-mem spacing		10	3017000085	Aluminum Rail, RH Front	1
	3097000581	28' Deck - 102" wide, 8" X-mem spacing		11	3017000082	Aluminum Rail, LH Rear (22' deck)	1
2	7493000009	Marker Light Grommet	6		3017000078	Aluminum Rail, LH Rear (24' deck)	
3	7590000249	Marker Light - Amber (Std)	4	12	3017000088	Aluminum Rail, RH Rear (22' deck)	1
	7590000239	Marker Light - Amber (LED)			3017000079	Aluminum Rail, RH Rear (24' deck)	
4	7590000245	Marker Light - Red (Std)	2	13	7115181650	Capscrew, 0.50"-13NC x 2.00"	10
	7590000238	Marker Light - Red (LED)		14	Not Required		
5	7493000010	Marker Light Grommet	2				
6	7590000250	Marker Light - Amber (Std)	2				
	7590000242	Marker Light - Amber (LED)					
7	7330000498	Reflector - Amber	8				
8	7330000497	Reflector - Red	4				

DECK - STEEL B.I.C. (_75T2B)

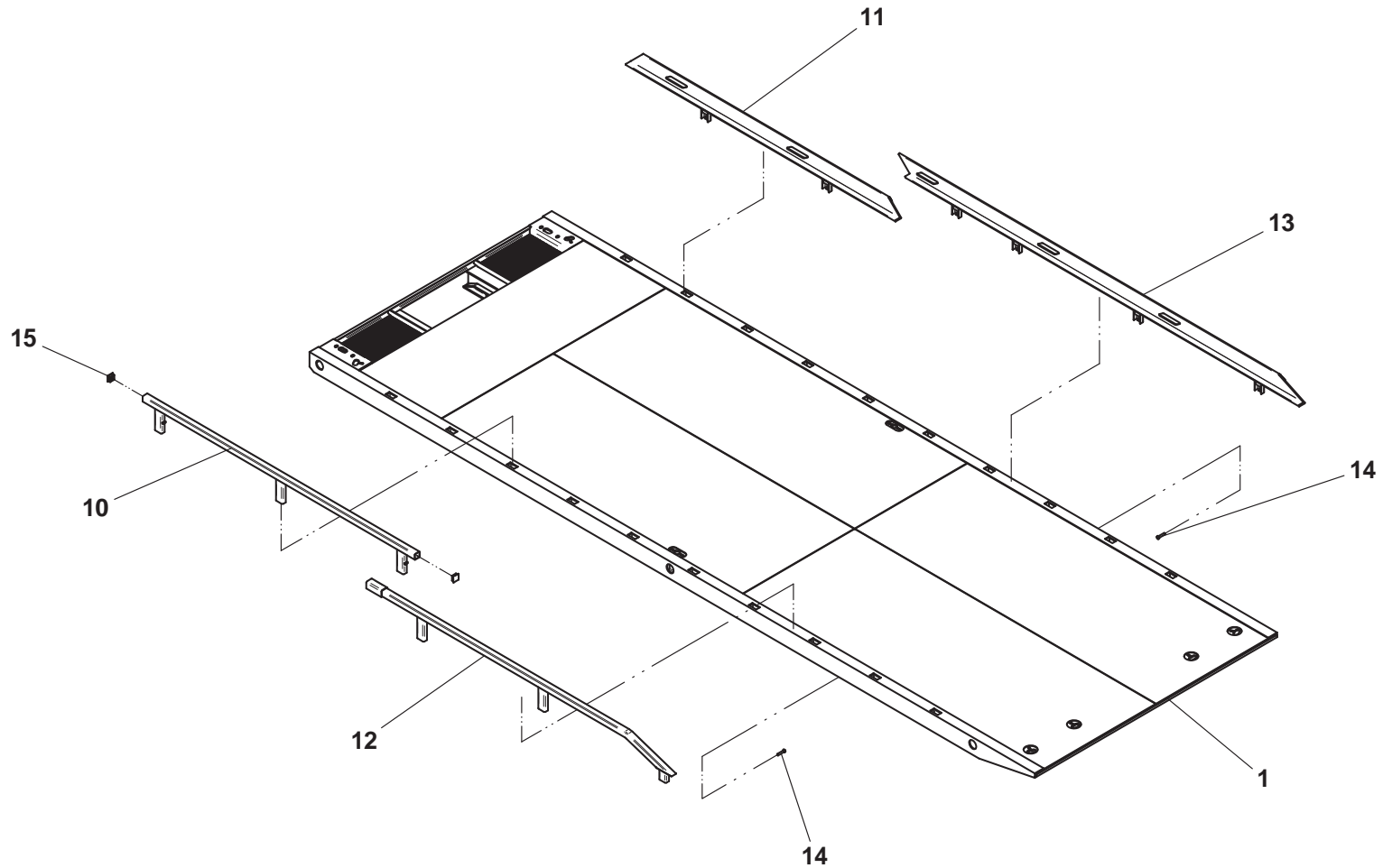

24' deck shown with standard removable steel rails on left side and optional aluminum removable rails on right side

DECK - STEEL B.I.C. TRANSPORTER (_75TRB)

ITEM	PART NO.	DESCRIPTION	QTY	ITEM	PART NO.	DESCRIPTION	QTY
1	3097000539	22' Deck - 95" wide, 12" X-mem spacing	1			<i>Optional Steel Tubular Removable Rails:</i>	
	3097000543	22' Deck - 95" wide, 8" X-mem spacing					
	3097000547	22' Deck - 102" wide, 12" X-mem spacing		11	3729000126	Steel Rail, LH Front	1
	3097000551	22' Deck - 102" wide, 8" X-mem spacing		12	3729000126	Steel Rail, RH Front	1
	3097000540	24' Deck - 95" wide, 12" X-mem spacing		13	3729000127	Steel Rail, LH Rear (22' deck)	1
	3097000544	24' Deck - 95" wide, 8" X-mem spacing			3729000129	Steel Rail, LH Rear (24' deck)	
	3097000548	24' Deck - 102" wide, 12" X-mem spacing		14	3729000128	Steel Rail, RH Rear (22' deck)	1
	3097000552	24' Deck - 102" wide, 8" X-mem spacing			3729000130	Steel Rail, RH Rear (24' deck)	
2	7493000009	Marker Light Grommet	6	15	7120000005	Capscrew, 0.50"-13NC x 2.50"	12
3	7590000249	Marker Light - Amber (Std)	4	16	7701000033	End Cap	4
	7590000239	Marker Light - Amber (LED)					
4	7590000245	Marker Light - Red (Std)	2			<i>Optional Aluminum Removable Rails:</i>	
	7590000238	Marker Light - Red (LED)					
5	7493000010	Marker Light Grommet	2				
6	7590000250	Marker Light - Amber (Std)	2	11	3017000084	Aluminum Rail, LH Front	1
	7590000242	Marker Light - Amber (LED)		12	3017000085	Aluminum Rail, RH Front	1
7	7330000498	Reflector - Amber	8	13	3017000082	Aluminum Rail, LH Rear (22' deck)	1
8	7330000497	Reflector - Red	4		3017000078	Aluminum Rail, LH Rear (24' deck)	
9	Contact Parts	Keruing Board	A/R	14	3017000083	Aluminum Rail, RH Rear (22' deck)	1
10	7786000007	Screw, 0.31"-18NC x 2.00"	A/R		3017000079	Aluminum Rail, RH Rear (24' deck)	
				15	7115181650	Capscrew, 0.50"-13NC x 2.00"	12
				16	Not Required		

DECK - STEEL B.I.C. TRANSPORTER (_75TRB)

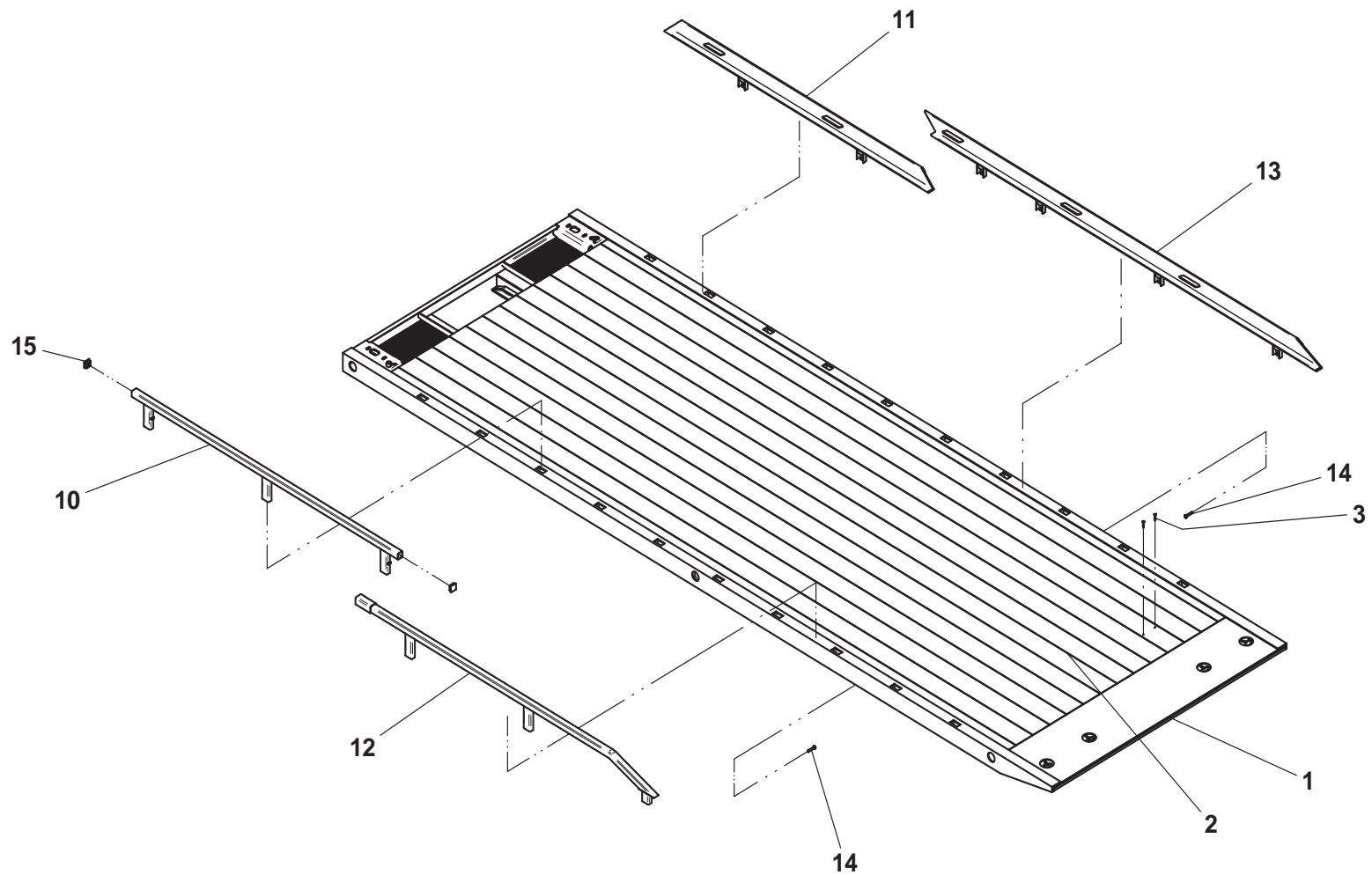

24' deck shown with standard removable steel rails on left side and optional aluminum removable rails on right side

STANDARD HEADBOARD & WINCH FREE SPOOL (10,000 LB WORM GEAR WINCH)

ITEM	PART NO.	DESCRIPTION	QTY	ITEM	PART NO.	DESCRIPTION	QTY
1	3241000140	Standard Headboard Weld - 40.50" (10,000 lb winch w/ free spool)	1	14	4763000348*+	Rod	1
	3241000148	Standard Headboard Weld - 40.50" (10,000 lb winch w/o free spool and 12,000 lb winch)		15	7660180234*+	Nut, 0.50"-20NF	1
	3241000141	Standard Headboard Weld - 45.50" (10,000 lb winch w/ free spool)		16	4178000673*+	Bracket	1
	3241000149	Standard Headboard Weld - 45.50" (10,000 lb winch w/o free spool and 12,000 lb winch)		17	7115150850*+	Capscrew, 0.31"-18NC x 1.00"	2
	3241000142	Standard Headboard Weld - 50.50" (10,000 lb winch w/ free spool)		18	7950150161*+	Flatwasher, 0.31" ID	4
	3241000150	Standard Headboard Weld - 50.50" (10,000 lb winch w/o free spool and 12,000 lb winch)		19	7660152601*+	Locknut, 0.31"-18NC	2
	3241000143	Standard Headboard Weld - 57.50" (10,000 lb winch w/ free spool)		20	4209000147*+	Bushing	1
	3241000151	Standard Headboard Weld - 57.50" (10,000 lb winch w/o free spool and 12,000 lb winch)		21	7690051274*+	Pin	2
2	4796000037	Gasket	2	22	7949000030*+	Nylon Washer	1
3	7105201650	Capscrew, 0.63"-18NF x 2.00"	4	23	7843000027*+	Spring	1
4	7950200152	Flatwasher, 0.63" ID	4	24	7551000017*+	Knob	1
5	7660200035	Nut, 0.63"-18NF	2	25	4632000009*+	Trim Lok	1
6	4178000671*+	Bracket	1				
7	4209000328*+	Bushing	1				
8	7082000010*+	Nylon Washer	2				
9	7950180161*+	Flatwasher, 0.50" ID	1				
10	7990000011*+	Yoke	1				
11	7691000046*+	Clevis Pin	2				
12	7082000009*+	Bearing Flange	1				
13	7950180143*+	Flatwasher, 0.50" ID	3				

* also available in complete Remote Free Spool Installation:
P/N 2970000021 for 10,000 lb worm gear winch
+ use with 10,000 lb winch only

STANDARD HEADBOARD & WINCH FREE SPOOL (10,000 LB WORM GEAR WINCH)

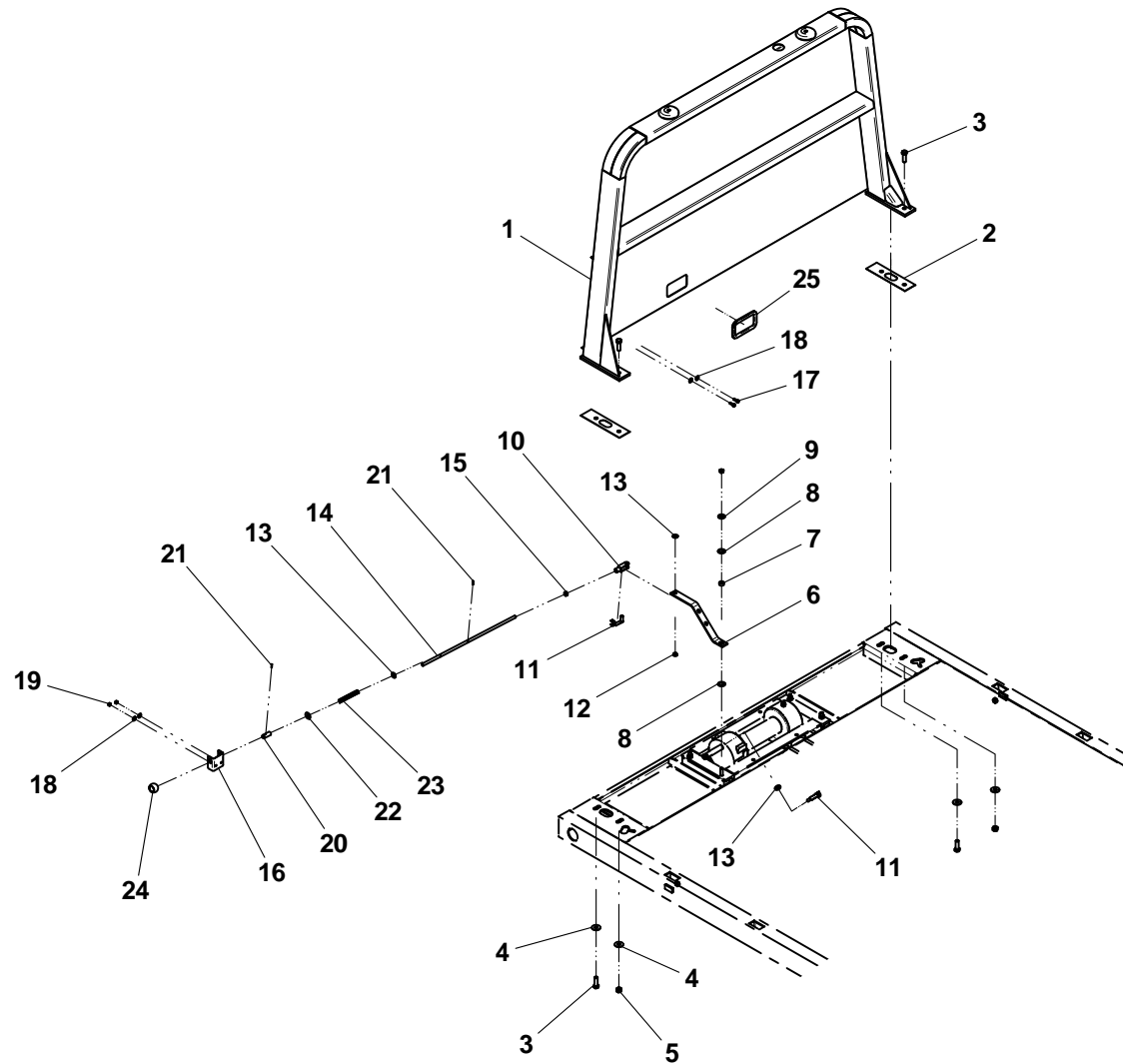

50.50" headboard shown with 10,000 lb worm gear winch

DELUXE HEADBOARD & WINCH FREE SPOOL (10,000 LB WORM GEAR WINCH)

ITEM	PART NO.	DESCRIPTION	QTY	ITEM	PART NO.	DESCRIPTION	QTY
1	3241000133	Standard Headboard Weld - 40.50" (10,000 lb winch w/ free spool)	1	11	7082000010*+	Nylon Washer	2
	3241000144	Standard Headboard Weld - 40.50" (10,000 lb winch w/o free spool and 12,000 lb winch)		12	7950180161*+	Flatwasher, 0.50" ID	1
	3241000134	Standard Headboard Weld - 45.50" (10,000 lb winch w/ free spool)		13	7990000011*+	Yoke	1
	3241000145	Standard Headboard Weld - 45.50" (10,000 lb winch w/o free spool and 12,000 lb winch)		14	7691000046*+	Clevis Pin	2
	3241000135	Standard Headboard Weld - 50.50" (10,000 lb winch w/ free spool)		15	7082000009*+	Bearing Flange	1
	3241000146	Standard Headboard Weld - 50.50" (10,000 lb winch w/o free spool and 12,000 lb winch)		16	7950180143*+	Flatwasher, 0.50" ID	3
	3241000136	Standard Headboard Weld - 57.50" (10,000 lb winch w/ free spool)		17	4763000252*+	Rod	1
	3241000147	Standard Headboard Weld - 57.50" (10,000 lb winch w/o free spool and 12,000 lb winch)		18	7660180234*+	Nut, 0.50"-20NF	1
				19	4178000673*+	Bracket	1
				20	7115150850*+	Capscrew, 0.31"-18NC x 1.00"	2
				21	7950150161*+	Flatwasher, 0.31" ID	4
				22	7660152601*+	Locknut, 0.31"-18NC	2
				23	4209000147*+	Bushing	1
				24	7690051274*+	Pin	2
				25	7949000030*+	Nylon Washer	1
				26	7843000027*+	Spring	1
				27	7551000017*+	Knob	1
				28	4632000009*+	Trim Lok	1
2	4796000037	Gasket	2				
3	7105201650	Capscrew, 0.63"-18NF x 2.00"	4				
4	7950200152	Flatwasher, 0.63" ID	4				
5	7660200035	Nut, 0.63"-18NF	2				
6	3391000014	Screen Weld (36.50", 40.50" & 45.50" headboards)	1				
	3391000017	Screen Weld (50.50" headboard)					
	3391000018	Screen Weld (57.50" headboard)					
7	4796000003	Gasket	1				
8	7759000015	Rivet	6				
9	4178000671*+	Bracket	1				
10	4209000328*+	Bushing	1				

* also available in Remote Free Spool Installation:
P/N 2970000021 for 10,000 lb worm gear winch
+ use with 10,000 lb winch only

DELUXE HEADBOARD & WINCH FREE SPOOL (10,000 LB WORM GEAR WINCH)

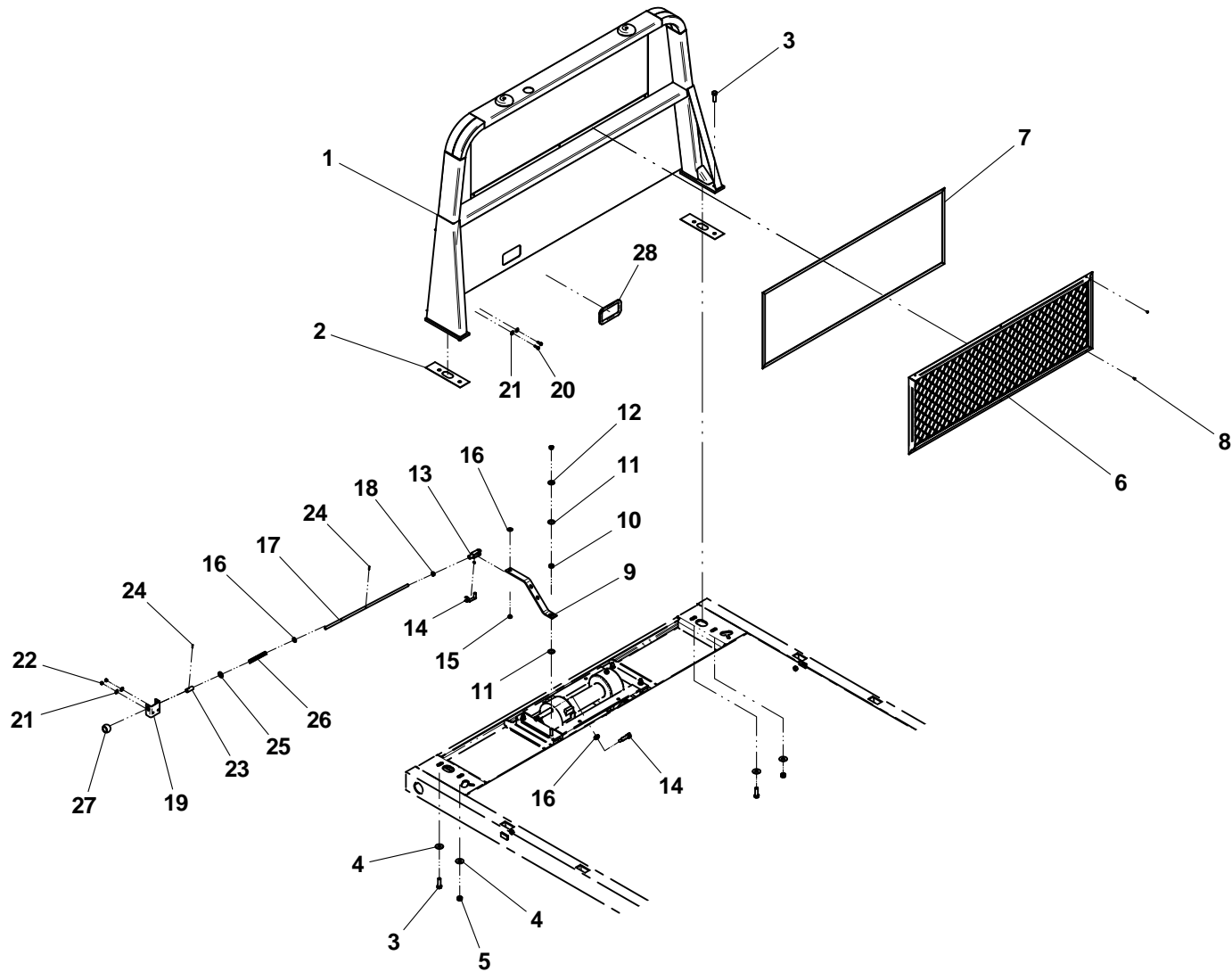

50.50" headboard shown with 10,000 lb worm gear winch

STATIONARY HEADBOARD & WINCH FREE SPOOL (10,000 LB WORM GEAR WINCH)

ITEM	PART NO.	DESCRIPTION	QTY	ITEM	PART NO.	DESCRIPTION	QTY
1	3241000161	Stationary Headboard Weld - 57.00"	1	28	7843000027*+	Spring	1
	3241000162	Stationary Headboard Weld - 62.00"		29	7551000017*+	Knob	1
	3241000163	Stationary Headboard Weld - 69.00"					
2	7105181450	Capscrew, 0.50"-20NF x 1.75"	8				
3	7950180153	Flatwasher, 0.50" ID	8				
4	7660182631	Locknut, 0.50"-20NF	8				
5	3391000014	Screen Weld (57.00" headboard)	1				
	3391000017	Screen Weld (62.00" headboard)					
	3391000018	Screen Weld (69.00" headboard)					
6	4796000003	Gasket	1				
7	7759000015	Rivet	6				
8	4705000607	Shim - 0.25"	A/R				
9	4705000608	Shim - 0.12"	A/R				
10	4178000672*+	Bracket	1				
11	4209000328*+	Bushing	1				
12	7082000010*+	Nylon Washer	2				
13	7950180161*+	Flatwasher, 0.50" ID	1				
14	7990000011*+	Yoke	1				
15	7691000046*+	Clevis Pin	2				
16	7082000009*+	Bearing Flange	1				
17	7950180143*+	Flatwasher, 0.50" ID	3				
18	4763000252*+	Rod	1				
19	7660180234*+	Locknut, 0.50"-20NF	1				
20	4178000674*+	Bracket	1				
21	4178000673*+	Bracket	1				
22	7115150850*+	Capscrew, 0.31"-18NC x 1.00"	2				
23	7950150161*+	Flatwasher, 0.31" ID	4				
24	7660152601*+	Locknut, 0.31"-18NC	2				
25	4209000147*+	Bushing	1				
26	7690051274*+	Pin	2				
27	7949000030*+	Nylon Washer	1				

* also available in complet Remote Free Spool Installation:
P/N 2970000021 for 10,000 lb worm gear winch
+ use with 10,000 lb winch only

STATIONARY HEADBOARD & WINCH FREE SPOOL (10,000 LB WORM GEAR WINCH)

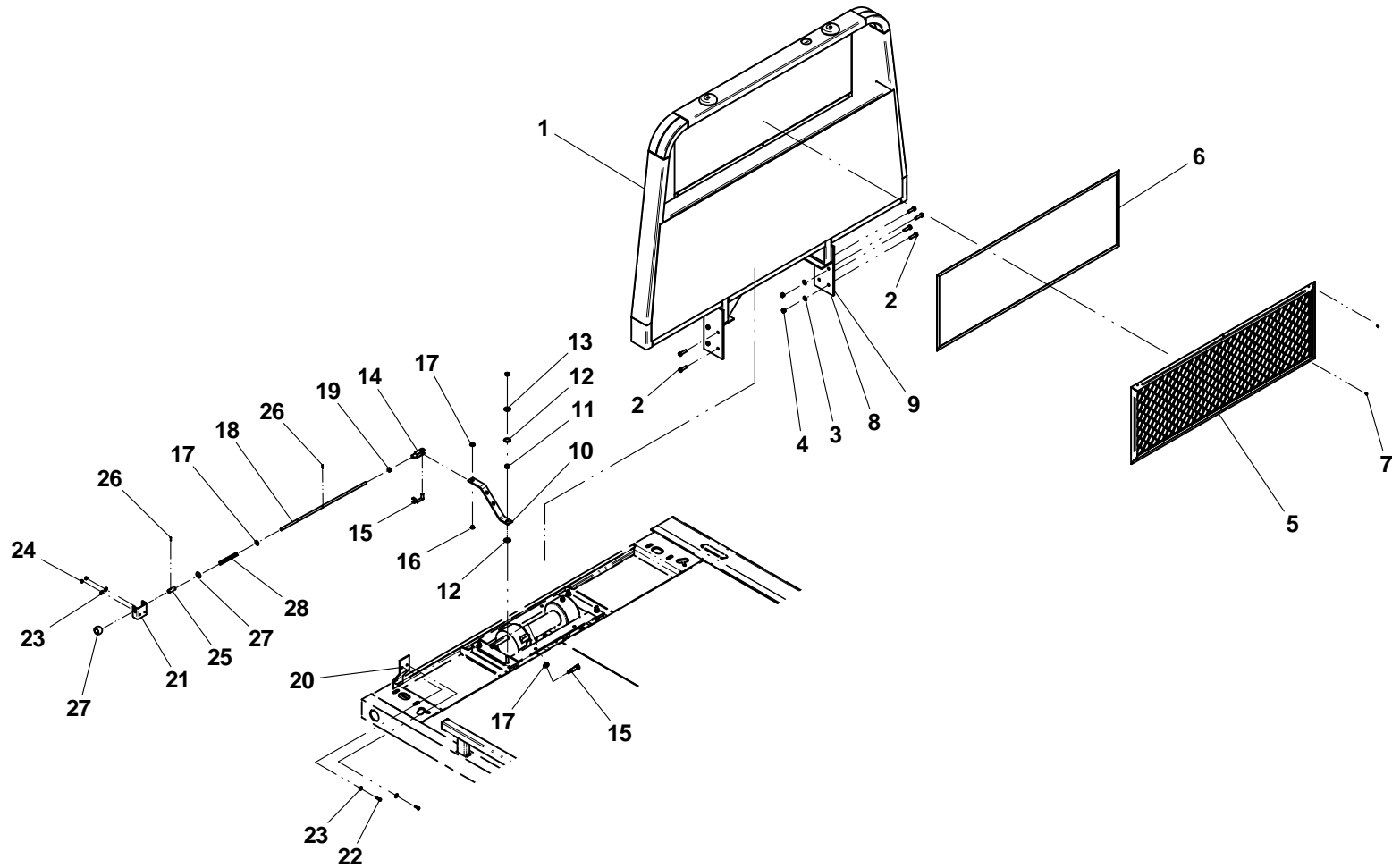

62.00" headboard shown with 10,000 lb worm gear winch

WINCH FREE SPOOL (12,000 LB WORM GEAR WINCH)

ITEM	PART NO.	DESCRIPTION	QTY
1	302000091	Arm Lever weld	1
2	7785150500	Set Screw, 0.31"-18NC x .31"	1
3	7950180143	Flatwasher, 0.50" ID	2
4	4017001194	Angle	1
5	7115150850	Capscrew, 0.31"-18NC x 1.00"	1
6	7950150161	Flatwasher, 0.31" ID	2
7	7660152601	Locknut, 0.31"-18NC	3
8	7843000007	Extension Spring	1
9	7111141407	Capscrew, 0.25"-20NC x 1.75"	1
10	7950140141	Flatwasher, 0.25" ID	1
11	7660142601	Locknut, 0.25"-20NC	1
12	7990000011	Yoke	1
13	7691000046	Clevis Pin	1
14	7660180234	Jam Nut 0.50"-20NF	1
15	4209000212	Bushing	1
16	4763000253	Rod	1
17	7254000016	Cap	1
18	7690051274	Pin	1
19	7115151250	Capscrew, 0.31"-18NC x 1.50"	2
20	4178000673	Bracket	1
21	4679000208	Pad	1
22	4632000030	Trim Loc	1

WINCH FREE SPOOL (12,000 LB WORM GEAR WINCH)

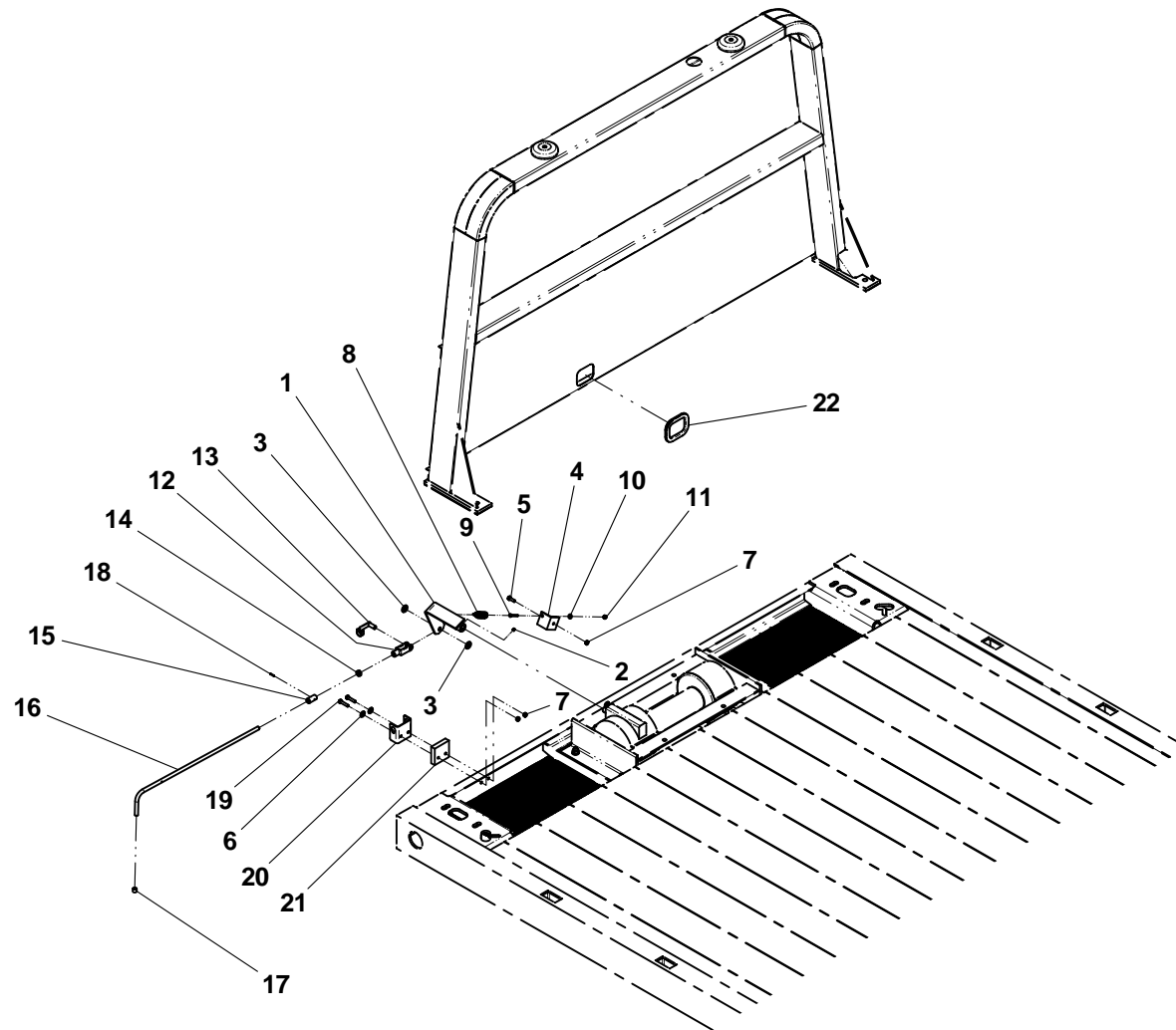

50.50" standard headboard shown

WORM GEAR WINCH (10,000 LB)

ITEM	PART NO.	DESCRIPTION	QTY
1	7970000123	Winch - 10,000 lb Worm Gear	1
2	7626000014	Orbit Motor	1
3	9970414952	Capscrew, 0.50"-13NC x 1.25"	2
4	7950180400	Lockwasher, 0.50" ID	2
5	7115181464	Carriage Bolt, 0.50"-13NC x 1.75" (steel decks)	3
	7115182864	Carriage Bolt, 0.50"-13NC x 3.5" (steel transporters)	
6	7115181864	Carriage Bolt, 0.50"-13NC x 2.25" (steel decks)	1
	7115183264	Carriage, 0.50"-13NC x 4.00" (steel transporters)	
7	7950180153	Flatwasher, 0.50" ID	4
8	7660182601	Locknut, 0.50"-13NC	4
9	4062000318	Bar (transporters only)	2
10	7248000064	Cable, 0.44" dia x 56' (10,000 lb winch)	1

Refer to manufacturer's manual for winch parts list

WORM GEAR WINCH (10,000 LB)

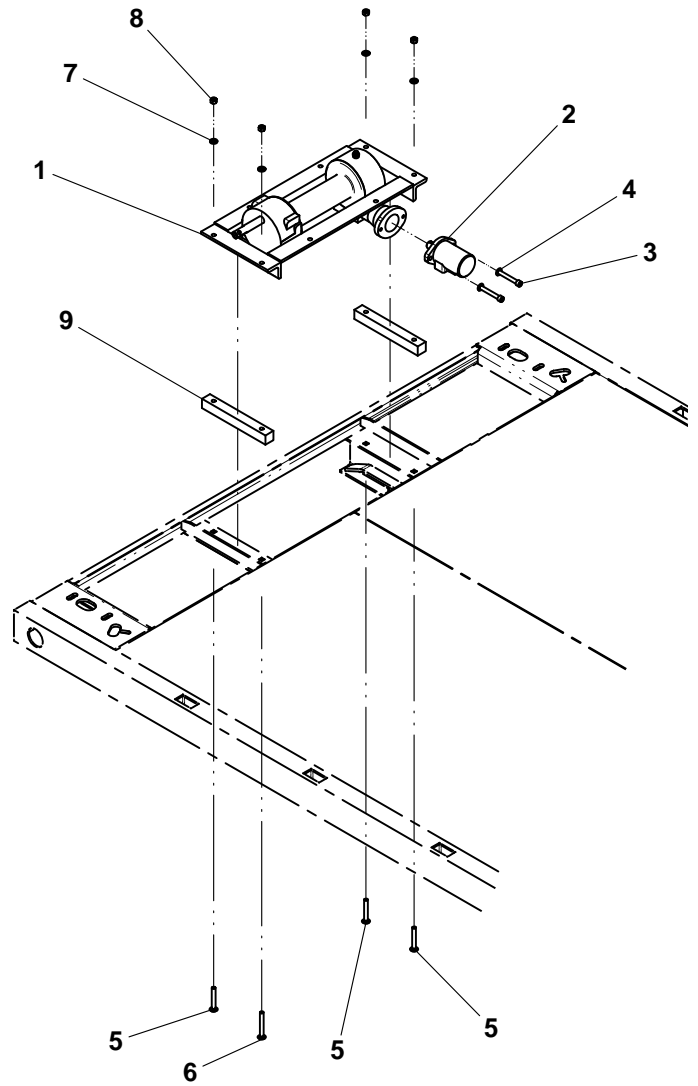

Item #10, Winch Cable, not shown

10,000 lb winch shown on transporter deck

WORM GEAR WINCH (12,000 LB)

ITEM	PART NO.	DESCRIPTION	QTY
1	7970000083	Winch -12,000 lb Worm Gear	1
2	7626000018	Orbit Motor	1
3	7115181250	Capscrew, 0.50"-13NC x 1.50"	2
4	7950180400	Lockwasher, 0.50" ID	2
5	7115181464	Carriage Bolt, 0.50"-13NC x 1.75"	4
6	7950180153	Flatwasher, 0.50" ID	4
7	7660182301	Locknut, 0.50"-13NC	4
8	7248000064	Cable, 0.44" dia x 56'	1

Refer to manufacturer's manual for winch parts list

WORM GEAR WINCH (12,000 LB)

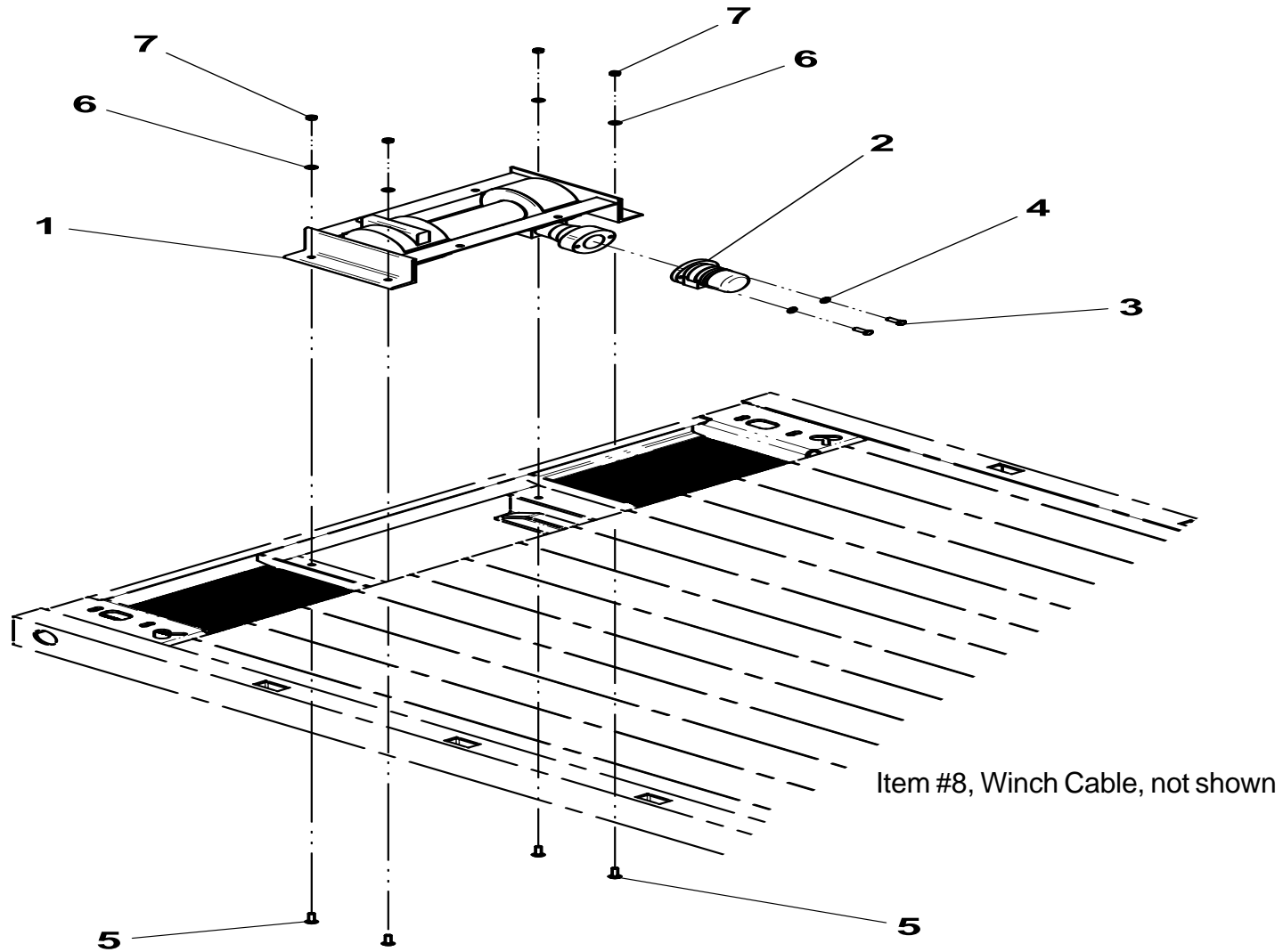

12,000 lb winch shown on transporter deck

WORM GEAR WINCH CABLE ROLLER GUIDE / TENSIONER PLATE

ITEM	PART NO.	DESCRIPTION	QTY
1	3178000433*	Bracket Weld	1
2	7115181464	Carriage Bolt, 0.50"-13NC x 1.75"	4
3	7950180153	Flatwasher, 0.50" ID	4
4	7660182601	Locknut, 0.50"-13NC	4
5	4706003766	Plate (10,000 lb winch)	1
	4706003857	Plate (12,000 lb winch)	
6	7843000035	Spring	2
7	4912000130*	Roller	1
8	4806000014*	Shaft	1
9	4912000394*	Roller	2
10	4806000011*	Shaft	2
11	7209000011*	Bushing	6
12	7949000034*	Spacer	4
13	7754000022*	Retaining Ring	6

* also available in Cable Guide / Tensioner Assembly, P/N 3249000036

WORM GEAR WINCH CABLE ROLLER GUIDE / TENSIONER PLATE

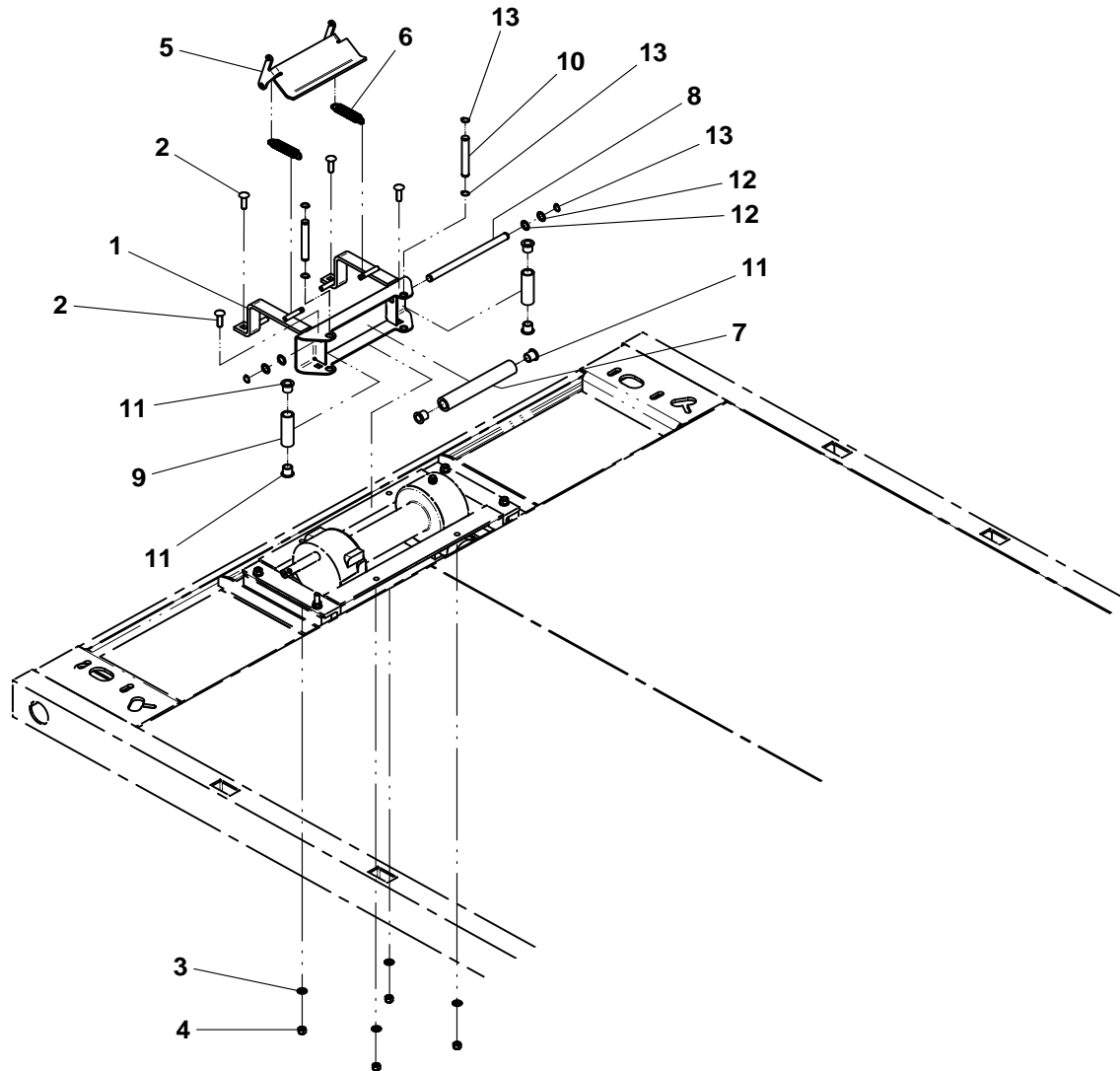

10,000 lb winch shown

SUBFRAME - 22' & 24' DECKS

ITEM	PART NO.	DESCRIPTION	QTY	ITEM	PART NO.	DESCRIPTION	QTY
1	3868000271	Subframe Weld	1	28	4017001294*	Mud Flap Angle, RH	1
2	3905000004	Trunnion Weld	1	29	4017001293*	Mud Flap Angle, LH	1
3	4497000358	Gusset	2				
4	7082000017*	Bearing	4				
5	4691000295	Pin	2				
6	7949000008	Washer, 2.25" ID	2				
7	7118162250	Capscrew, 0.38"-16NC x 2.75"	2				
8	7660162601	Locknut, 0.38"-16NC	6				
9	4178000305	Bracket	2				
10	3320000122	Tilt Cylinder Assembly	2				
11	3691000166	Pin Weld	2				
12	3691000092	Pin Weld	2				
13	4209000244	Bushing	4				
14	7115160950	Capscrew, 0.38"-16NC x 1.12"	4				
15	3320000121	Roll Cylinder Assembly	1				
16	4691000268	Pin	1				
17	7754000006	Retaining Ring	2				
18	4679000166	Pad	1				
19	4178000308	Bracket	1				
20	7660182631	Locknut, 0.50"-20NF	2				
21	7701000050*	Plug	4				
22	7105181450	Capscrew, 0.50:-20NF x 1.75"	2				
23	7105201850	Capscrew, 0.63"-18NF x 2.25"	8				
24	7950200242	Flatwasher, 0.63" ID	8				
25	7660202347	Locknut, 0.63"-18NF	8				
26	3178000234*	Light Box, RH	1				
27	3178000233*	Light Box, LH	1				

* included in Subframe Weld, P/N 3868000271

SUBFRAME - 22' & 24' DECKS

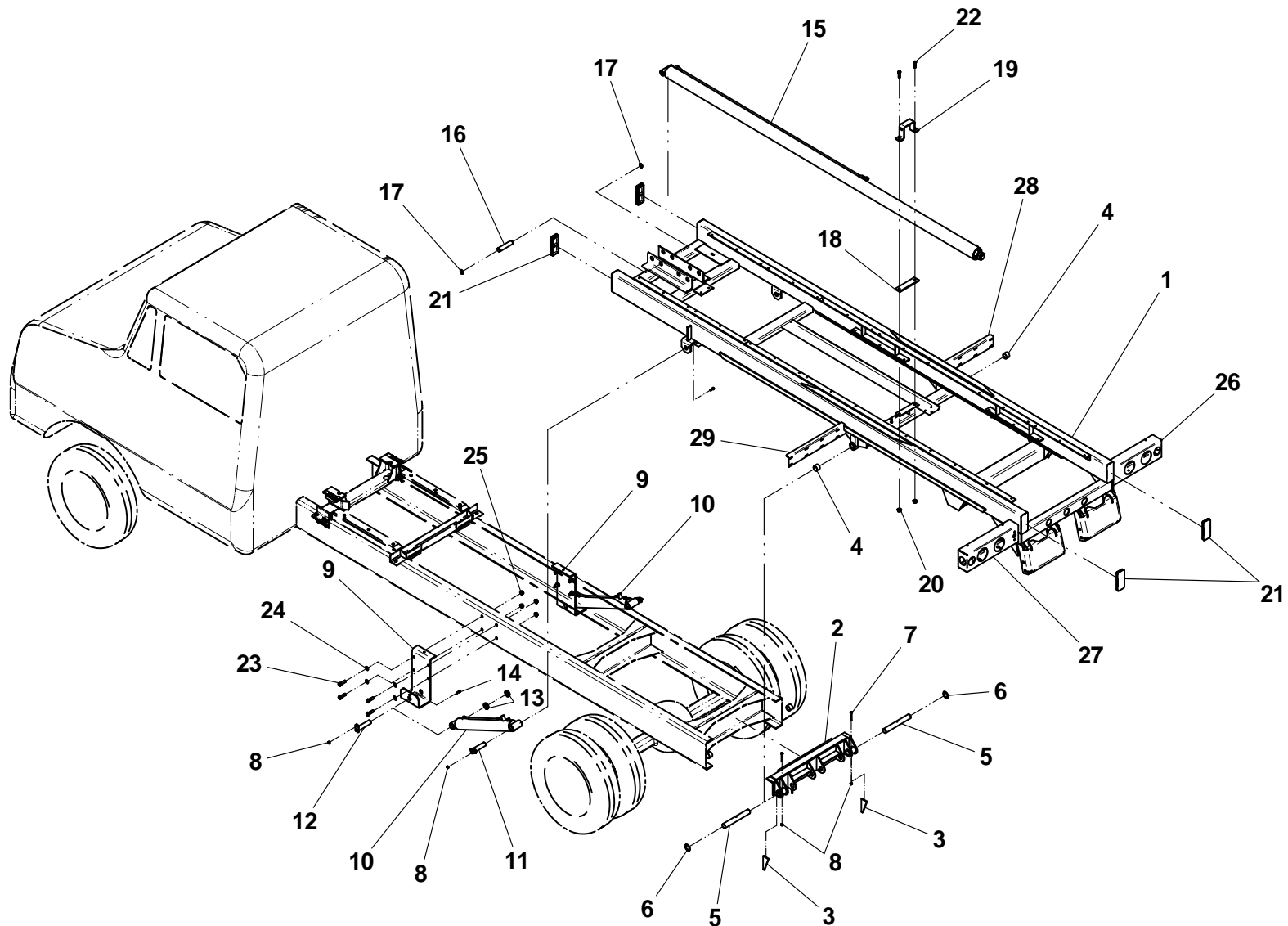

SUBFRAME - 26' & 28' DECKS

ITEM	PART NO.	DESCRIPTION	QTY	ITEM	PART NO.	DESCRIPTION	QTY
1	3868000272	Subframe Weld	1	33	4679000166	Pad	1
2	3905000004	Trunnion Weld	1	34	4178000308	Bracket	1
3	4497000358	Gusset	2	35	7115181450	Capscrew, 0.50"-13NC x 1.75"	2
4	7082000017*	Bearing	4	36	7660182601	Locknut, 0.50"-13NC	2
5	4691000295	Pin	2	37	7701000050*	Plug	2
6	7949000008	Washer, 2.25" ID	2	38	3178000234*	Light Box, RH	1
7	7118162250	Capscrew, 0.38"-16NC x 2.75"	2	39	3178000233*	Light Box, LH	1
8	7660162601	Locknut, 0.38"-16NC	2	40	4017001294*	Mud Flap Angle, RH	1
9	4178000288	Bracket, LH	1	41	4017001293*	Mud Flap Angle, LH	1
10	4178000289	Bracket, RH	1				
11	3320000129	Tilt Cylinder Weld	2				
12	3062000015	Bar Weld, LH	1				
13	3062000014	Bar Weld, RH	1				
14	4831000079	Spacer, 0.50"	2				
15	4831000083	Spacer, 0.25"	2				
16	4831000084	Spacer, 0.12"	2				
17	4017001093	Angle	2				
18	3691000164	Pin Weld	2				
19	3691000184	Pin Weld	2				
20	4209000204	Bushing	4				
21	7105202250	Capscrew, 0.63"-18NF x 2.75"	4				
22	7105201650	Capscrew, 0.63"-18NF x 2.00"	4				
23	7660202347	Locknut, 0.63"-18NF	8				
24	7115160850	Capscrew, 0.38"-16NC x 1.00"	2				
25	7660162301	Locknut, 0.38"-16NC	4				
26	7115161050	Capscrew, 0.38"-16NC x 1.25"	2				
27	7105181450	Capscrew, 0.50"-20NF x 1.75"	4				
28	7950180153	Flatwasher, 0.50" ID	4				
29	7660182333	Locknut, 0.50"-20NF	4				
30	3320000121	Roll Cylinder Assembly	1				
31	4691000268	Pin	1				
32	7754000006	Retaining Ring	2				

* included in Subframe Weld, P/N 3868000272

SUBFRAME - 26' & 28' DECKS

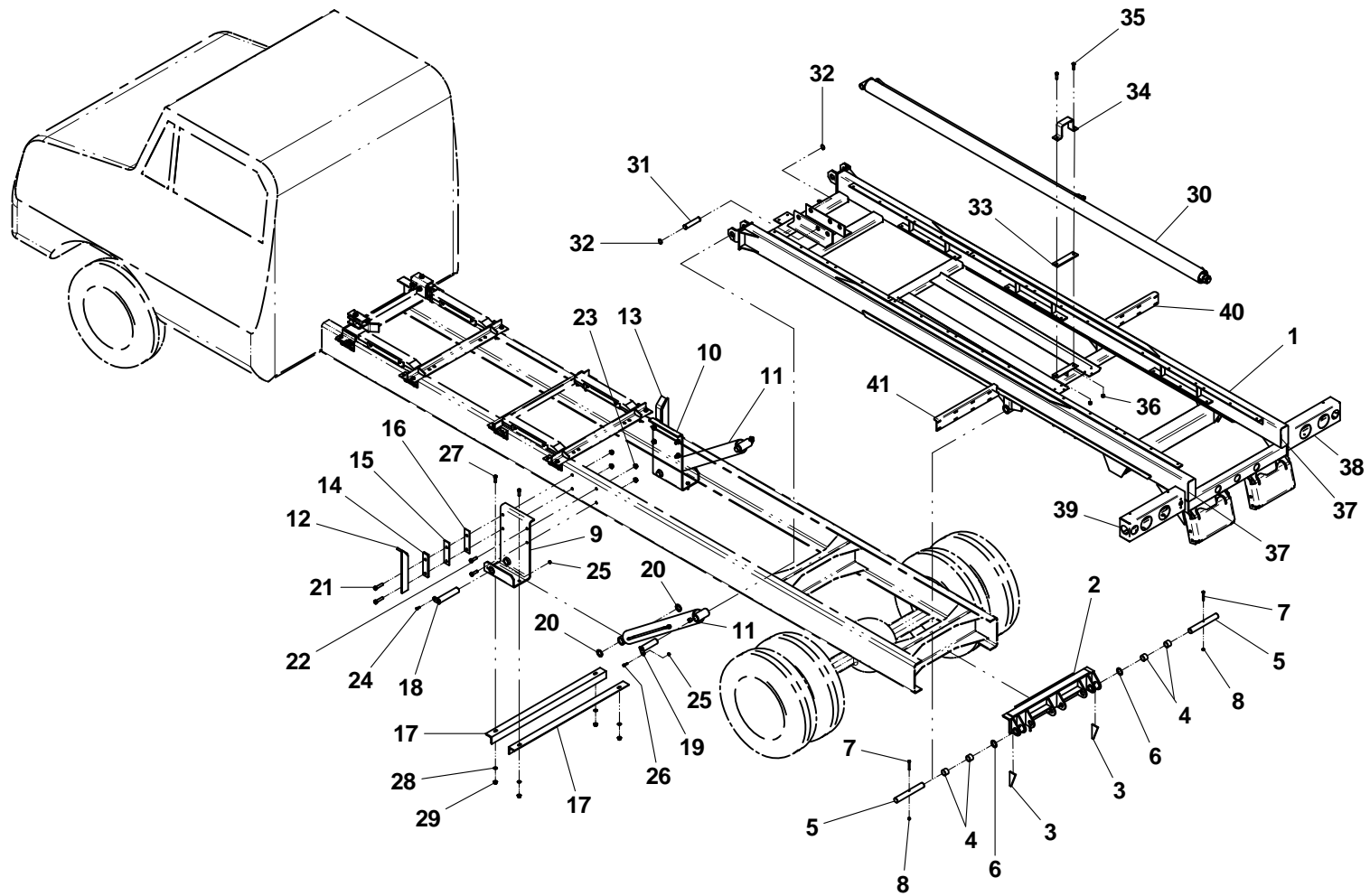

HOLD DOWN - 22' & 24' DECKS

ITEM	PART NO.	DESCRIPTION	QTY
1	3558000013*	Hold Down Weld	1
2	4017001271	Angle	2
3	7105181450	Capscrew, 0.50"-20NF x 1.75"	8
4	7950180153	Flatwasher, 0.50" ID	12
5	7660182631	Locknut, 0.50-20NF	8
6	7274000046	Retaining Clamp	2
7	7105201850	Capscrew, 0.63"-18NF x 2.25"	4
8	7660202347	Locknut, 0.63"-18NF	4
9	7701000063	Plug	4
10	4679000153*	Wear Pad	2
11	7118161026*	Flathead Screw, 0.38"-16NC x 1.25"	6
12	7660162601*	Locknut, 0.38-16NC	6
13	4679000221*	Wear Pad	2
14	4812000071*	Shim - 0.12"	2
15	4812000072*	Shim - 0.06"	2
16	7114151218*	Capscrew, 0.31"-18NC x 1.50"	4
17	7660152601*	Locknut, 0.31"-18NC	4

* also available in Hold Down Assembly, P/N 3558000014

HOLD DOWN - 22' & 24' DECKS

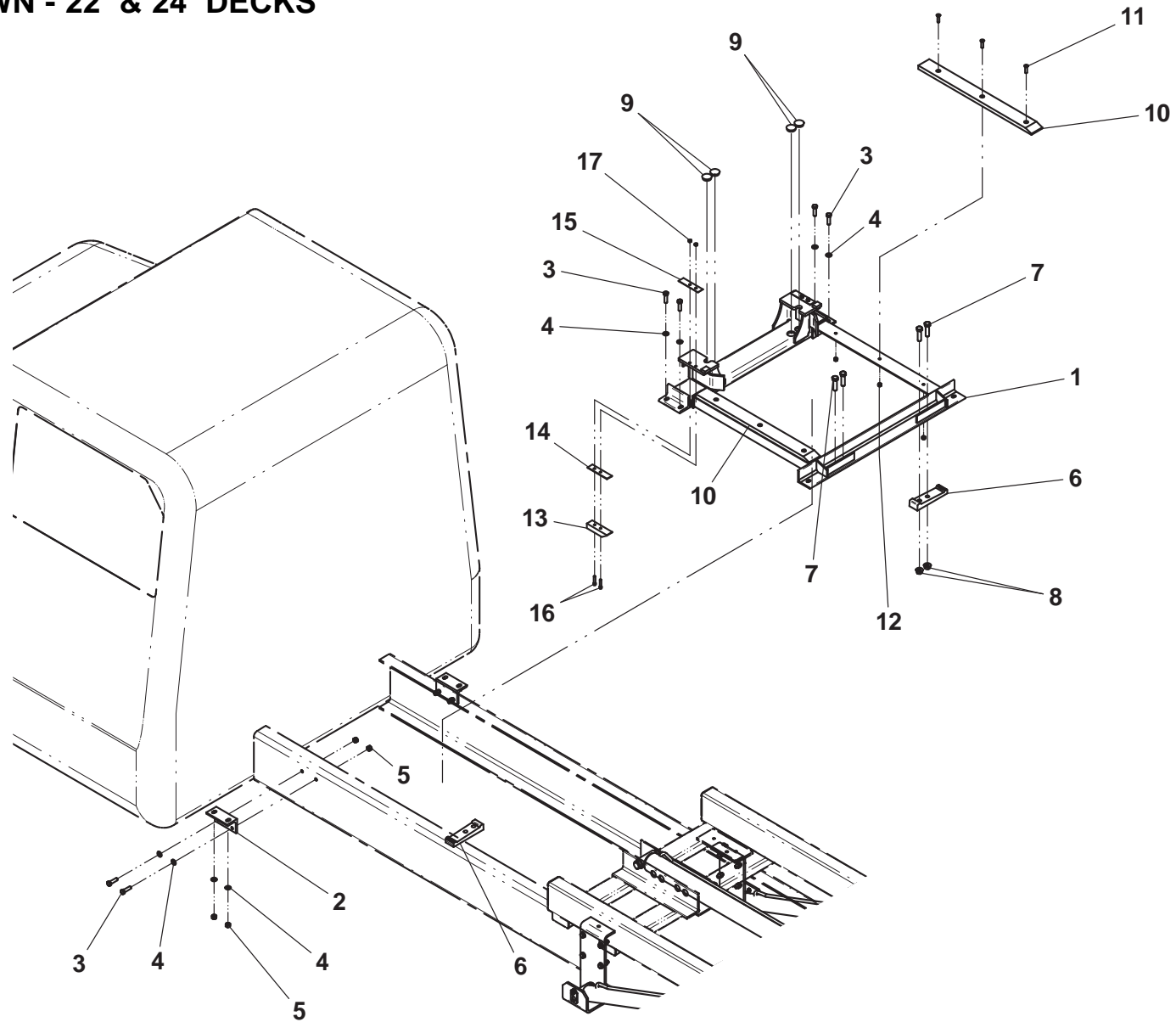

HOLD DOWN - 26' & 28' DECKS

ITEM	PART NO.	DESCRIPTION	QTY
1	3558000008	Hold Down Weld - Primary	1
2	4017001271	Angle	8
3	7105181450	Capscrew, 0.50"-20NF x 1.75"	26
4	7660182333	Locknut, 0.50"-20NF	16
5	7950180153	Flatwasher, 0.50 ID	20
6	7660182631	Locknut, 0.50"-20NF	10
7	4679000194	Pad	4
8	7790152056	Screw, 0.31"-18NC x 1.25"	16
9	7105201250	Capscrew, 0.63"-18NF x 1.50"	2
10	7259000015	Hold Down Shoe LH	1
11	7259000016	Hold Down Shoe RH	1
12	4706003025	Rub Plate LH	1
13	4706003026	Rub Plate RH	1
14	4706003027	Plate	2
15	7105202050	Capscrew, 0.63"-18NF x 2.50"	4
16	7660202347	Locknut, 0.63"-18NF	4
17	3558000007	Hold Down Weld - Secondary	1

HOLD DOWN - 26' & 28' DECKS

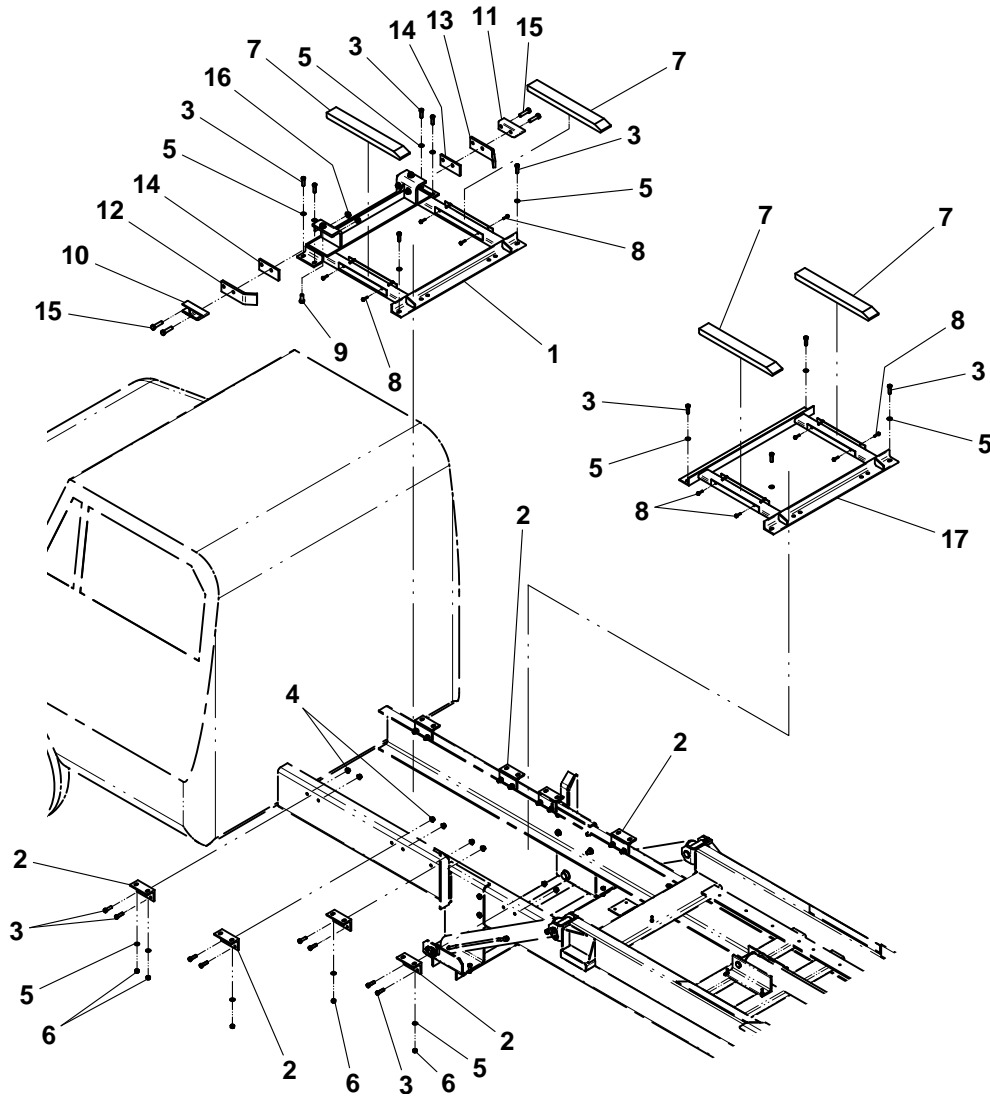

SLIDE PAD

ITEM	PART NO.	DESCRIPTION	QTY
1	4679000145*	Slide Pad (22' & 24' decks)	14
	4679000145	Slide Pad (26' & 28' decks)	16
2	7118161026*	Screw, 0.38"-16NC x 1.25" (22' & 24' decks)	42
	7118161026	Screw, 0.38"-16NC x 1.25" (26' & 28' decks)	48
3	7660162601*	Locknut, 0.38"-16NC (22' & 24' decks)	42
	7660162603	Locknut, 0.38"-16NC (26' & 28' decks)	48

* included in Slide Pad Kit, P/N 9577000228

SLIDE PAD

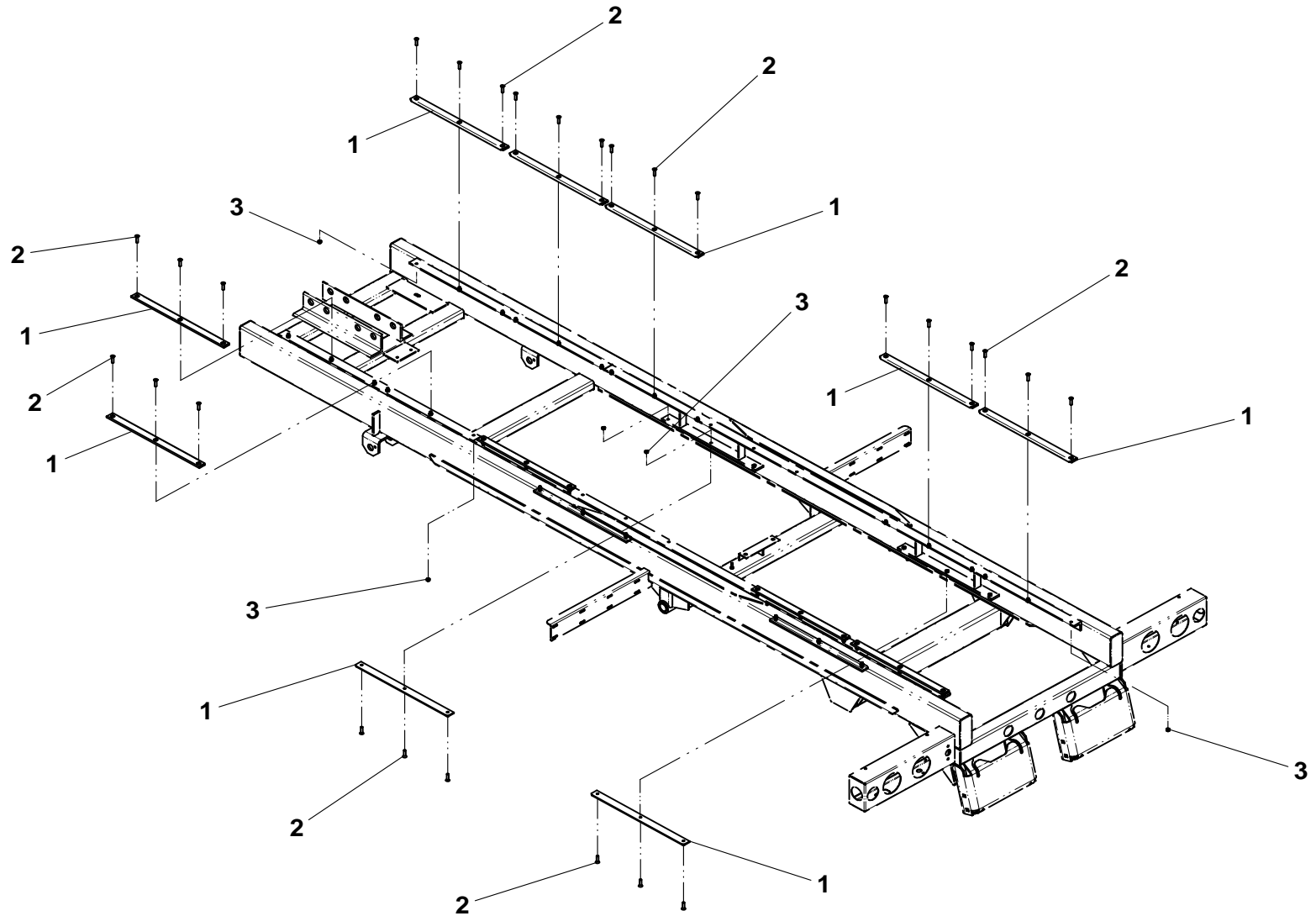

MUD FLAP

ITEM	PART NO.	DESCRIPTION	QTY
1	763800004	Mud Flap - Standard, 30" long	2
	763800013	Mud Flap - High Frame, 36" long	
2	4706000233	Plate	2
3	7111150864	Carriage Bolt, 0.31"-18NC x 1.00"	8
4	7660152601	Locknut, 0.31"-18NC	8

MUD FLAP

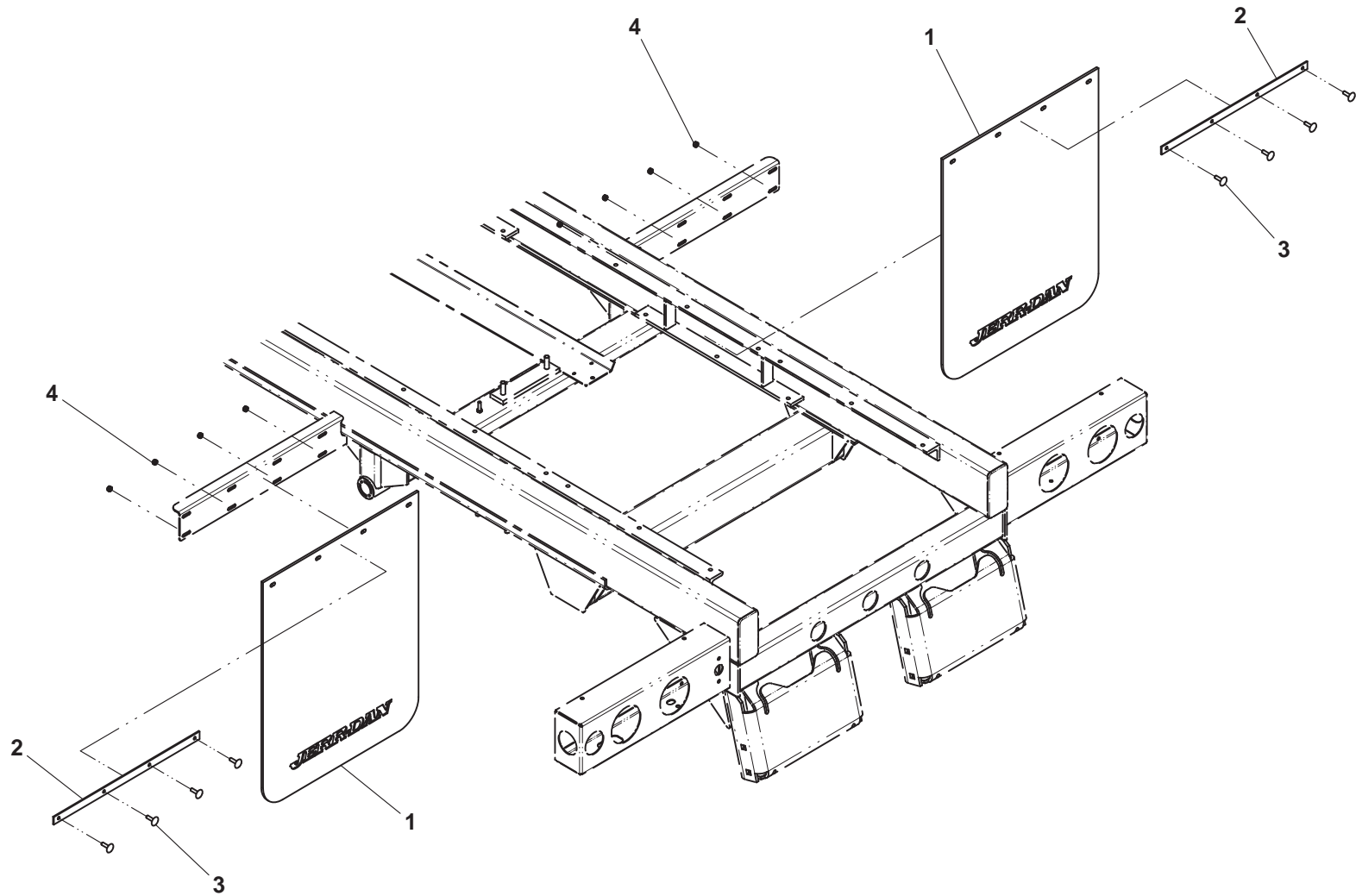

FINAL ASSEMBLY

ITEM	PART NO.	DESCRIPTION	QTY
1	3190000037	Bumper Tube Weld - Short	2
	3190000034	Bumper Tube Weld - Long	
2	7115181064	Carriage Bolt, 0.50"-13NC x 1.25"	8
3	7660182601	Locknut, 0.50"-13NC	8
4	4314000043	Light Box Cover	2
5	7661000042	U-Nut, 0.25"-20NC	8
6	7949000023	Nylon Washer, 0.26" ID	10
7	7114140529	Screw, 0.25"-20NC x 0.63"	8
8	7493000002	Grommet	4
9	7590000248	Back-Up Light - White (Std)	2
10	7590000247	Stop/Tail/Turn Light - Red (Std)	2
	7590000241	Stop/Tail/Turn Light - Red (LED)	
11	7493000009	Grommet	4
12	7590000245	Marker Light - Red (Std)	4
	7590000238	Marker Light - Red (LED)	
13	7493000023	Grommet	3
14	7590000246	Marker Light - Red (Std)	3
	7590000240	Marker Light - Red (LED)	
15	7493000010	Grommet	1
16	7590000251	License Plate Light	1
17	7011000007	Back-Up Alarm	1
18	7114140528	Screw, 0.25"-20NC x 0.63"	2
19	7660142601	Locknut, 0.25-20NC	2
20	7701000049	Plug	1
21	7701000055	Plug	2
22	7330000497	Reflector - Red	8
23	7330000428	Reflective Tape	2
24	4314000070	Cover Plate	2
25	7790161253	Screw, 0.38"-16NC x 0.75"	8
26	7679000020	Non-Skid Pad	2

FINAL ASSEMBLY

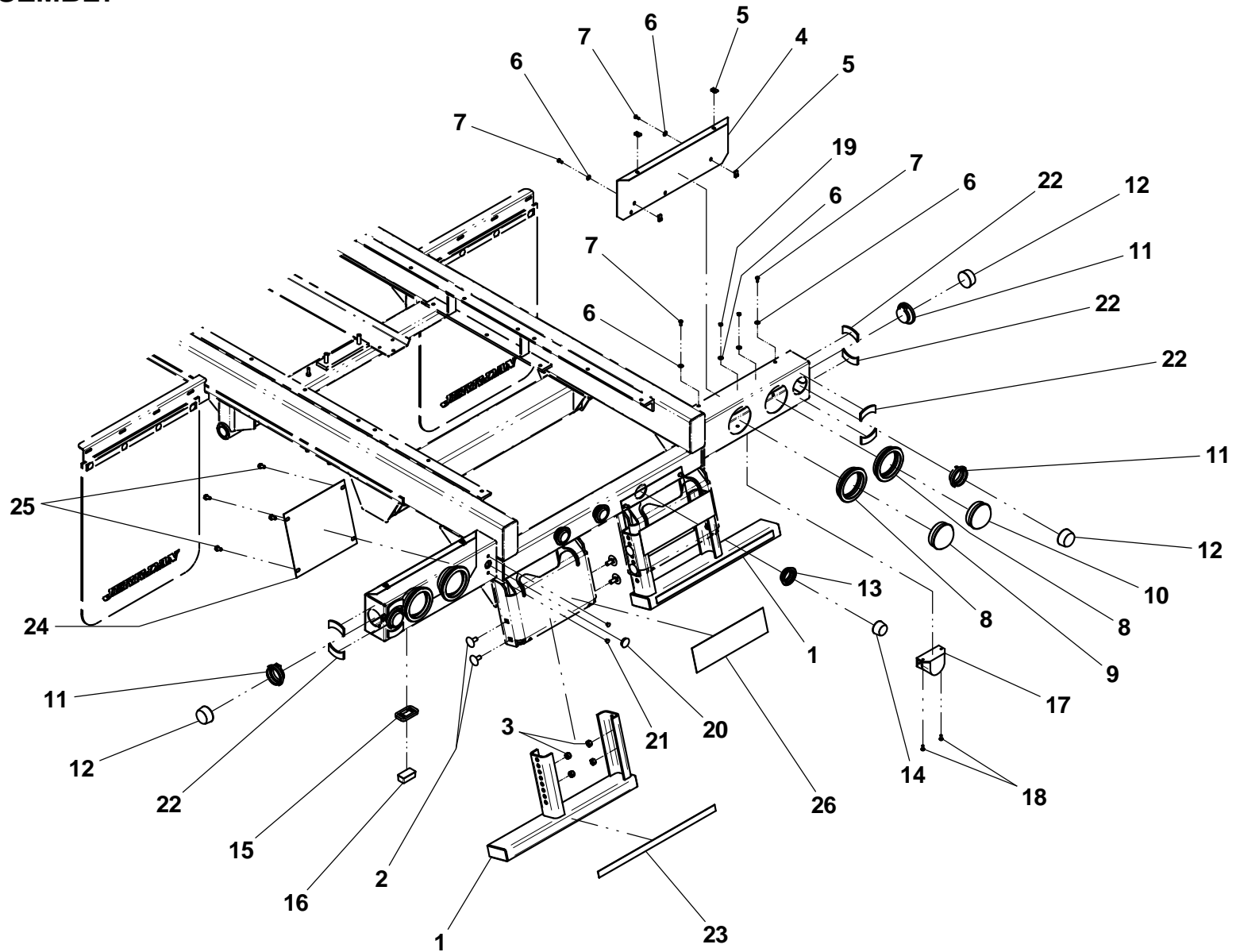

HYDRAULIC RESERVOIR AND TOOLBOX / BASKET

ITEM	PART NO.	DESCRIPTION	QTY*
1	4178000331	Mounting Bracket - Short	
	4178000291	Mounting Bracket - Std	
	4178000339	Mounting Bracket - Long	
2	4178000330	Mounting Bracket - Short	
	4178000290	Mounting Bracket - Std	
	4178000338	Mounting Bracket - Long	
3	3750000018	Hydraulic Reservoir Assembly	
4	7183000004+	Breather Filler Cap Assembly	
5	7470000009+	Level / Temperature Gauge	
6	7430000014+	Strainer	
7	7105181450	Capscrew, 0.50"-20NF x 1.75"	
8	7950180153	Flat Washer, 0.50" ID	
9	7660182631	Locknut, 0.50"-20NF	
10	7115150850	Capscrew, 0.31"-18NC x 1.00"	
11	7950150161	Flatwasher, 0.31" ID	
12	7660152601	Locknut, 0.31"-18NC	
13	3899000130	Toolbox Assembly - 36" x 18" x 18"	
	3899000131	Toolbox Assembly - 36" x 18" x 14"	
	3899000132	Toolbox Assembly - 48" x 18" x 18"	
	3899000133	Toolbox Assembly - 60" x 18" x 18"	
14	4679000256^	Rubber Pad (36" Toolbox)	
	4679000257^	Rubber Pad (48" Toolbox)	
	4679000258^	Rubber Pad (60" Toolbox)	
15	7118181216	Capscrew, 0.50"-13NC x 1.50"	
16	7660182301	Locknut, 0.50"-13NC	
17	4706002361	Plate	
18	4017000777	High Mount Angle	
19	3899000053	Basket - 15" deep	
	3899000075	Basket - 24" deep	
20	4632000015	Moulding - 15" deep basket	
	4632000048	Moulding - 24" deep basket	
21	7002000410	Stainless Steel Cover Plate for Basket includes rivets	

+ also available in Hydraulic Reservoir Assembly, P/N 3750000018

^ included in Toolbox Assembly

* Quantities vary depending on Hydraulic Tank / Toolbox / Basket mounting configuration.

HYDRAULIC RESERVOIR AND TOOLBOX / BASKET

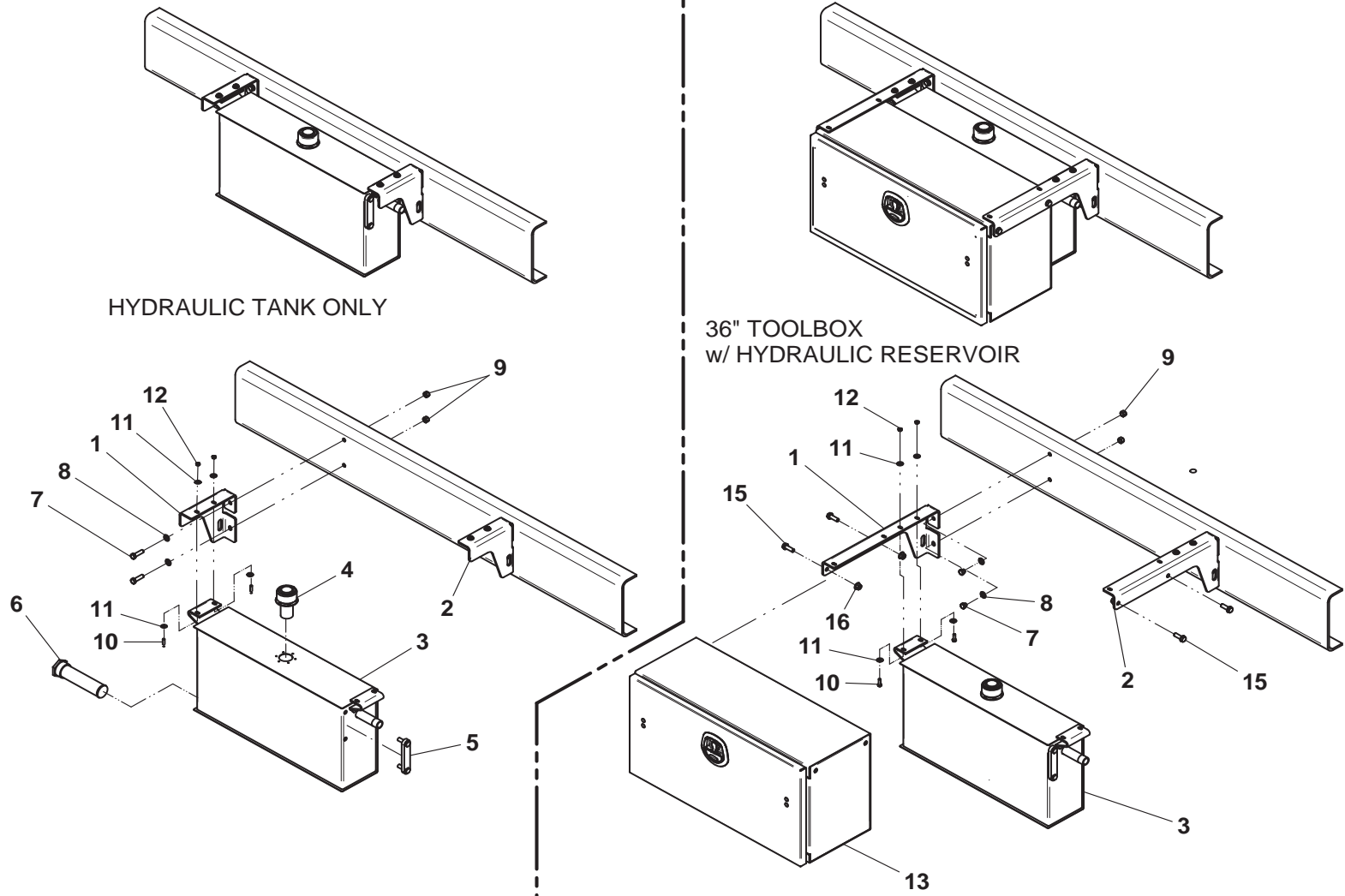

Item #14, Toolbox Rubber Pad, not shown

HYDRAULIC RESERVOIR AND TOOLBOX / BASKET

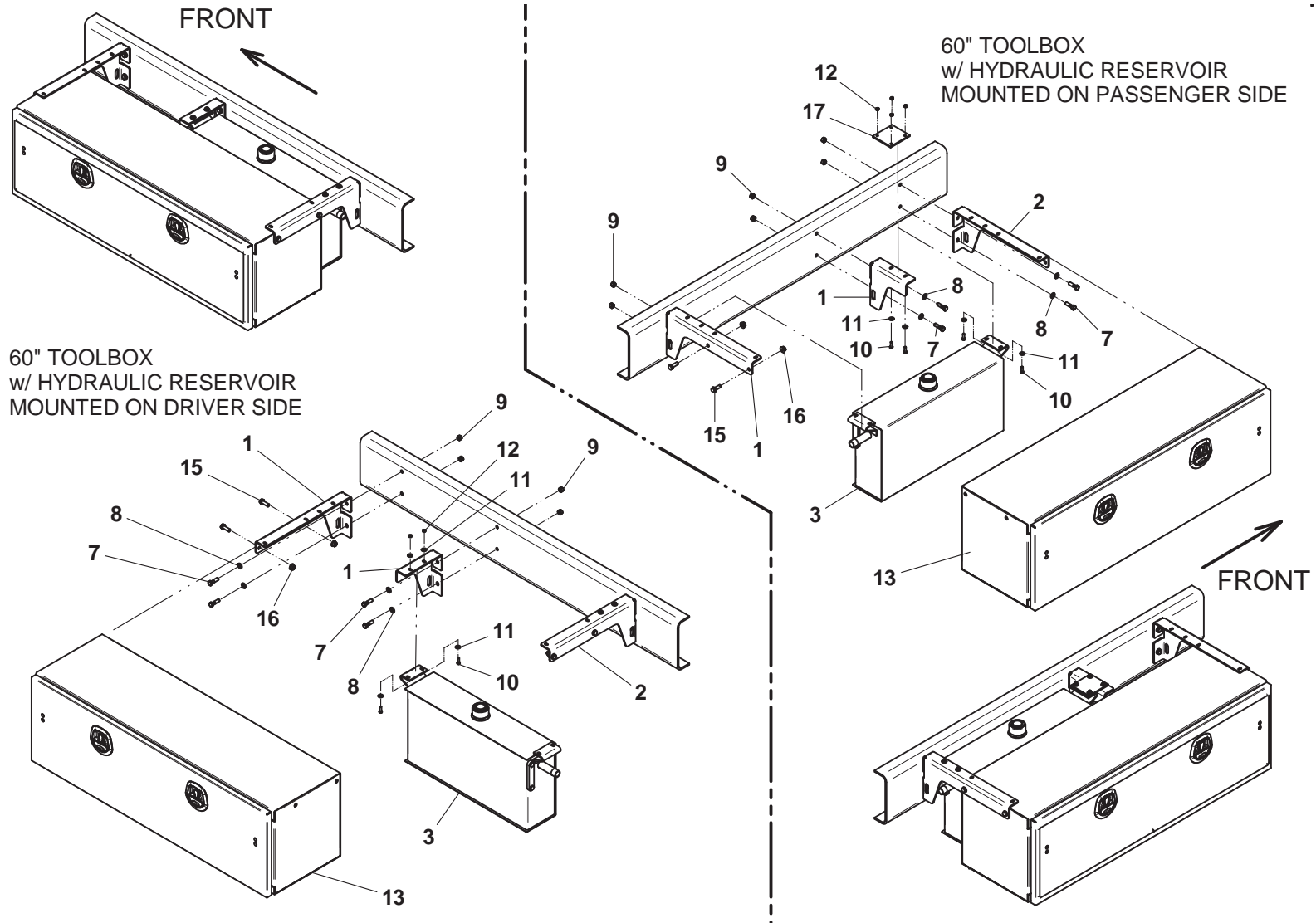

Item #14, Toolbox Rubber Pad, not shown

HYDRAULIC RESERVOIR AND TOOLBOX / BASKET

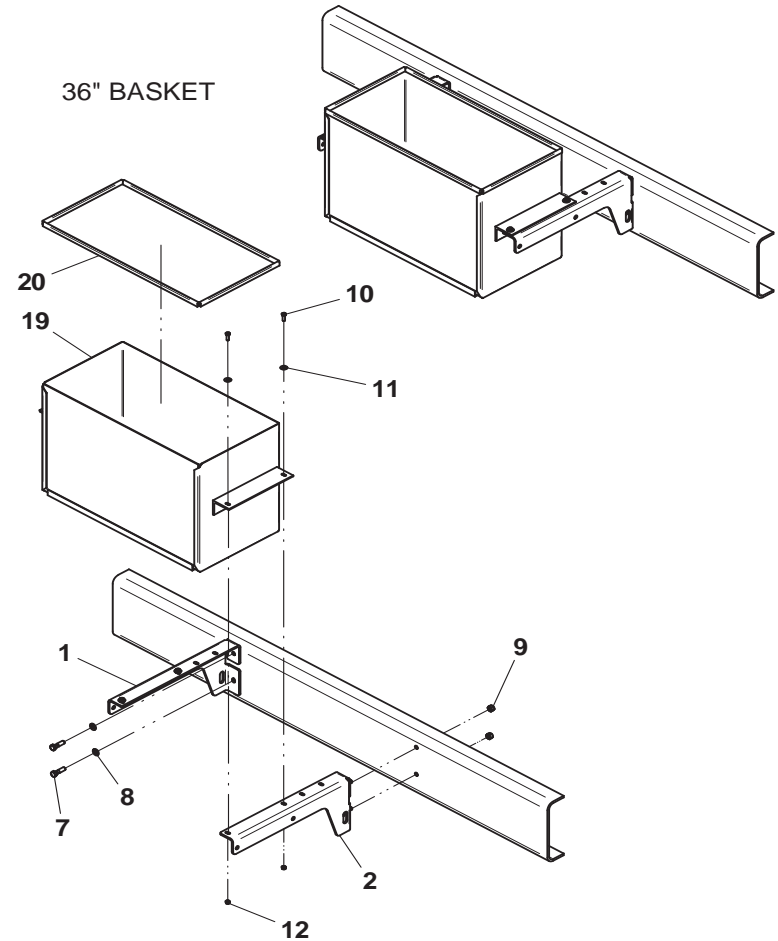
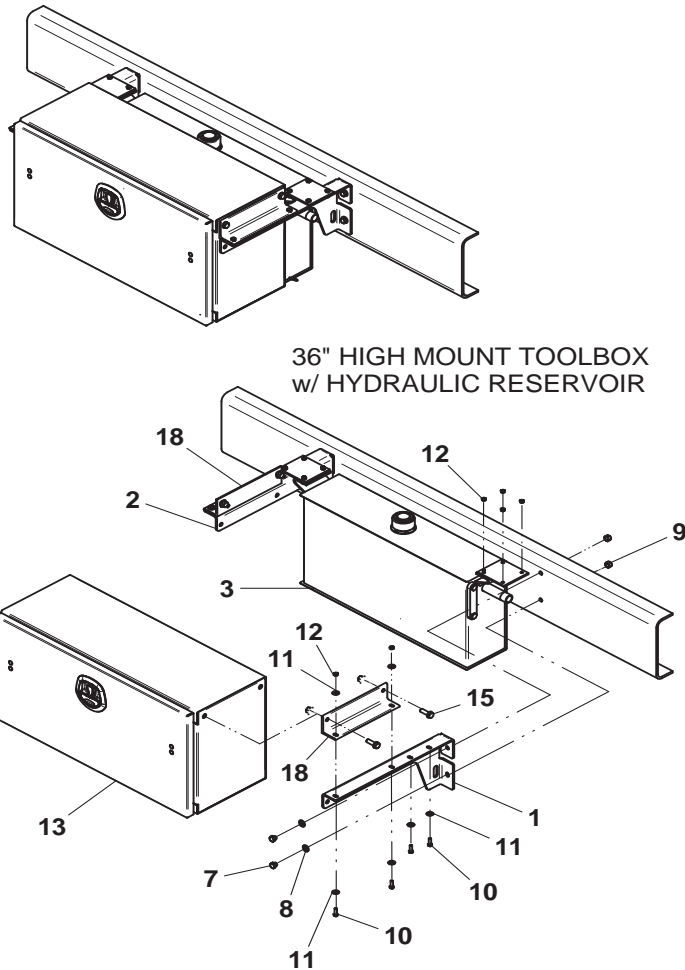

Items #14, Toolbox Rubber Pad and #21, Stainless Cover for Basket, not shown

TOOLBOX

ITEM	PART NO.	DESCRIPTION	QTY*
1	4679000256	Rubber Pad (36" toolbox)	1
	4679000257	Rubber Pad (36" narrow toolbox)	1
	4679000258	Rubber Pad (48" toolbox)	1
	4679000259	Rubber Pad (60" toolbox)	1
2	4796000009	Gasket (36" toolbox)	1
	4796000010	Gasket (48" toolbox)	1
	4796000011	Gasket (60" toolbox)	1
3	9899000014	Toolbox Door Assembly (36" toolbox)	1
	9899000015	Toolbox Door Assembly (48" toolbox)	1
	9899000016	Toolbox Door Assembly (60" toolbox)	1
4	7585000019^	Latch	1
5	7555000016^	Hinge (36" toolbox)	1
	7555000015^	Hinge (48" toolbox)	2
	7555000016^	Hinge (60" toolbox)	2
6	7759000020^	Rivet (36" toolbox)	9
	7759000020^	Rivet (48" toolbox)	14
	7759000020^	Rivet (60" toolbox)	18
7	4178000599^	Bracket	2
8	7114140465^	Carriage Bolt, 0.25"-20NC x 0.50"	4
9	7660142604^	Locknut, 0.25" -20NC	4
10	7592000005^	S Link	4
11	7248000114^	Cable	2

* Quantities listed are for one toolbox

^ also included in Toolbox Door Assembly

TOOLBOX

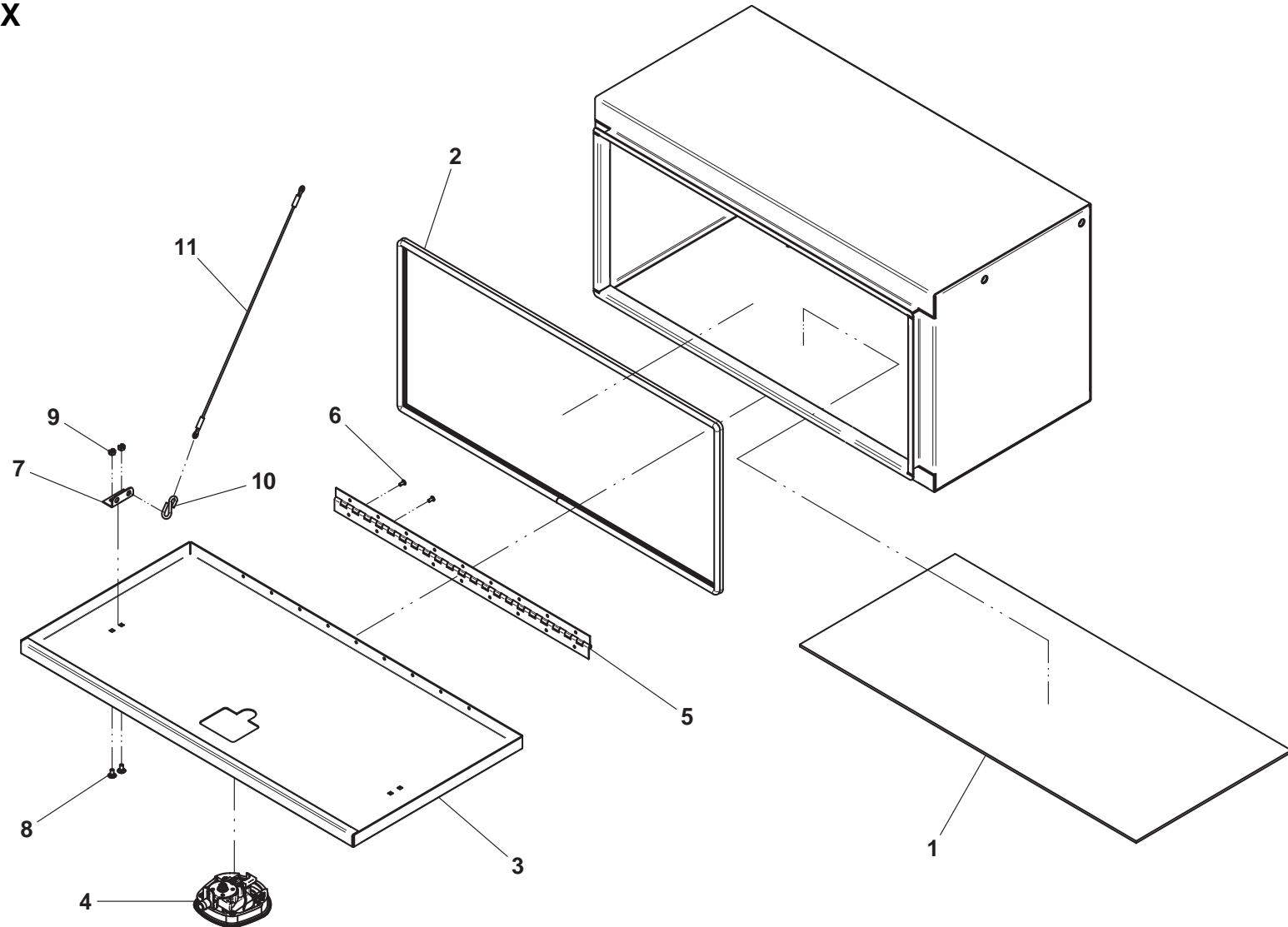

36" Toolbox shown

TOOLBOX SHELF

ITEM	PART NO.	DESCRIPTION	QTY
1	4017001403	Angle	2
2	4811000841	Shelf (36" toolbox)	1
	4811000843	Shelf (48" toolbox)	
	4811000868	Shelf (60" toolbox)	
3	7115150850	Capscrew, 0.31"-18NC x 1.00"	4
4	7950150161	Flatwasher, 0.31" ID	8
5	7660152601	Locknut, 0.31"-18NC	4

TOOLBOX SHELF

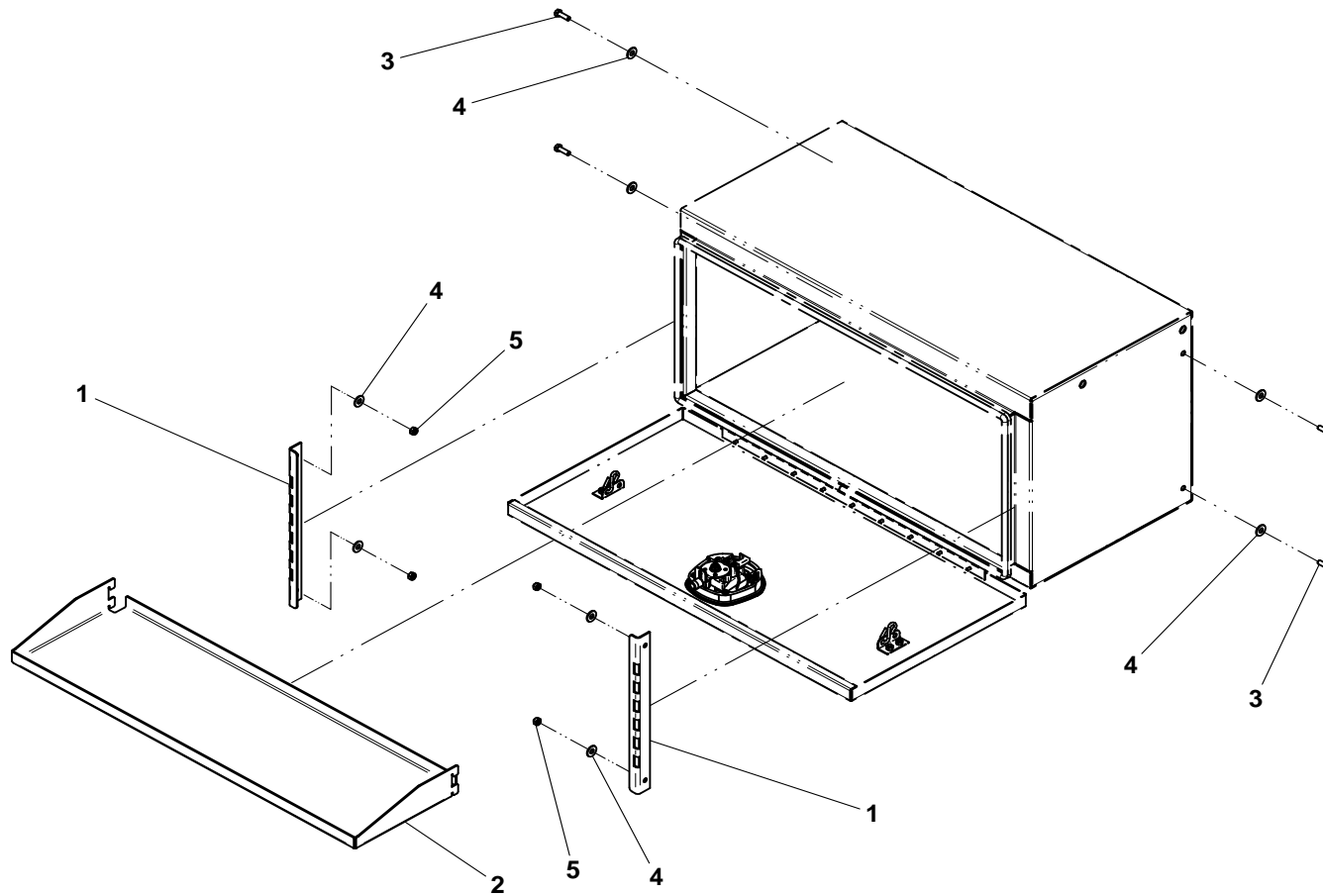

36" Toolbox shown

TOOLBOX LIGHT

ITEM	PART NO.	DESCRIPTION	QTY
1	4178000578*	Bracket	1
2	7590000273*	Dome Lamp	1
3	7870000115*	Switch	1
4	7280000007*	Wire Mount Clip	3
5	7661000047*	Panel Nut	4
6	7790100856*	Screw, #10 x 0.50"	4
7	7443000377	Fitting	1
8	7552000297	Toolbox Light Harness	1

* included in Toolbox Light Bracket Assembly

TOOLBOX LIGHT

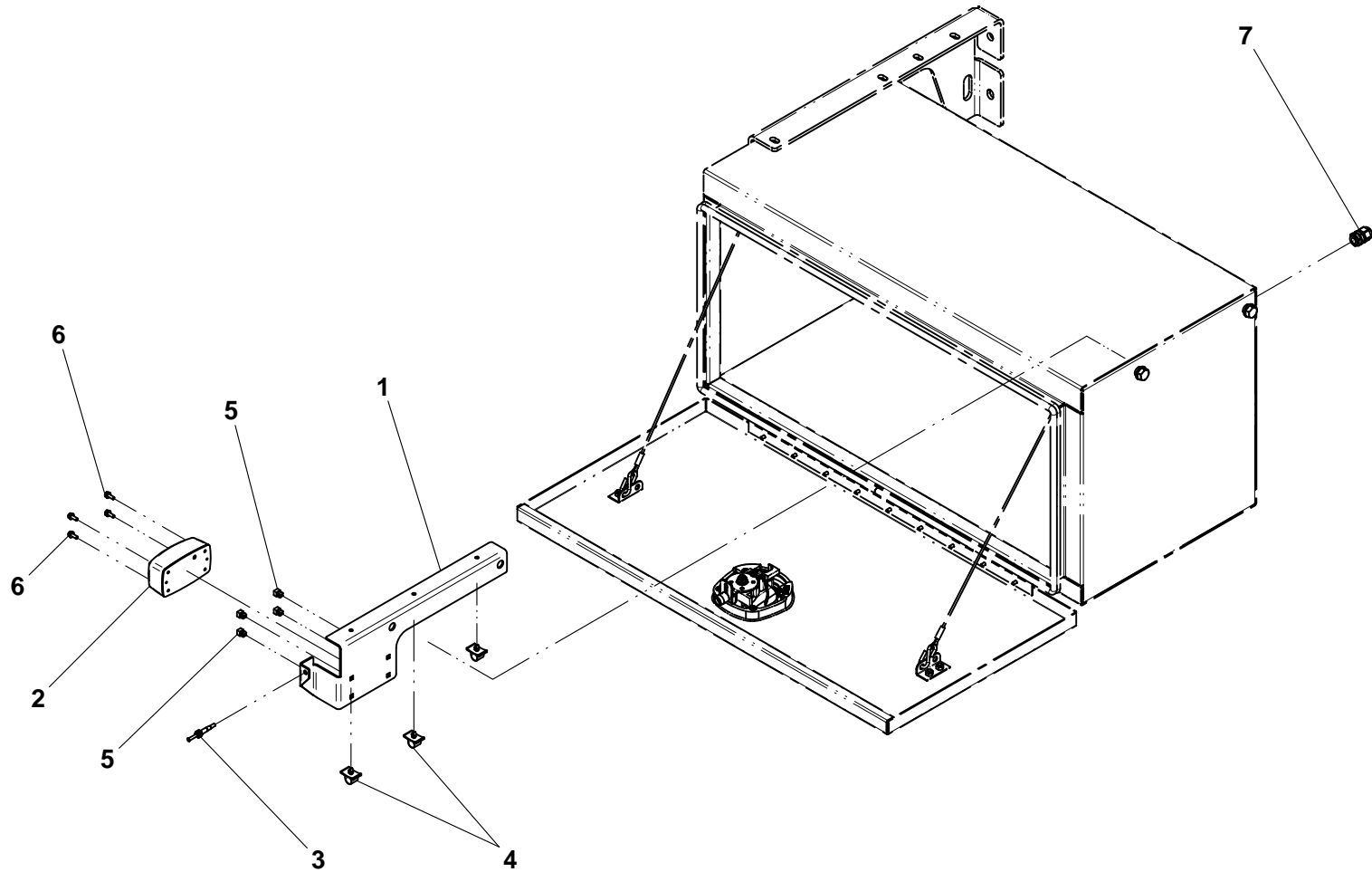

Item #8, Toolbox Light Harness, not shown
48" Toolbox Shown

DUAL CONTROLS - 3 BANK

ITEM	PART NO.	DESCRIPTION	QTY	ITEM	PART NO.	DESCRIPTION	QTY
1	4263000431	Channel	1	29	7949000054	Washer, 0.34" ID	8
2	7950180161	Flatwasher, 0.50" ID	4	30	7330000456	Control Panel, LH	1
3	7660182601	Locknut, 0.50"-13NC	4	31	7330000457	Control Panel, RH	1
4	4263000430	Channel	1	32	7759000006	Pop Rivet	8
5	7790151253	Screw, 0.31"-18NC x 0.75"	12	33	7590000087	Lamp	2
6	3935000115	Control Valve	1	34	7791060872	Screw, #6 x 0.50"	4
7	7111161050	Capscrew, 0.38"-16NC x 1.25"	4	35	7280000007	Wire Clip	11
8	7950160161	Flatwasher, 0.38" ID	4				
9	7660162601	Locknut, 0.38"-16NC	4				
10	4763000280	Control Rod	3				
11	4763000279	Control Rod	3				
12	7690101200	Clevis Pin	3				
13	7691000056	Cotter Pin	3				
14	7115150850	Capscrew, 0.31"-18NC x 1.00"	9				
15	7949000011	Flatwasher, 0.31" ID	9				
16	4831000069	Spacer	9				
17	7660152601	Locknut, 0.31"-18NC	17				
18	4606000065	Lug	4				
19	7115150664	Carriage Bolt, 0.31"-18NC x 0.75"	8				
20	7950150000	Washer, 0.31" ID	8				
21	4691000141	Pin	2				
22	7754000009	Retaining Ring	4				
23	7551000018	Control Handle	2				
24	7551000020	Control Handle	2				
25	7551000021	Control Handle	2				
26	4211000001	Bushing	4				
27	7950220141	Flatwasher, 0.75" ID	2				
28	7560000003	Control Hood	2				

DUAL CONTROLS - 3 BANK

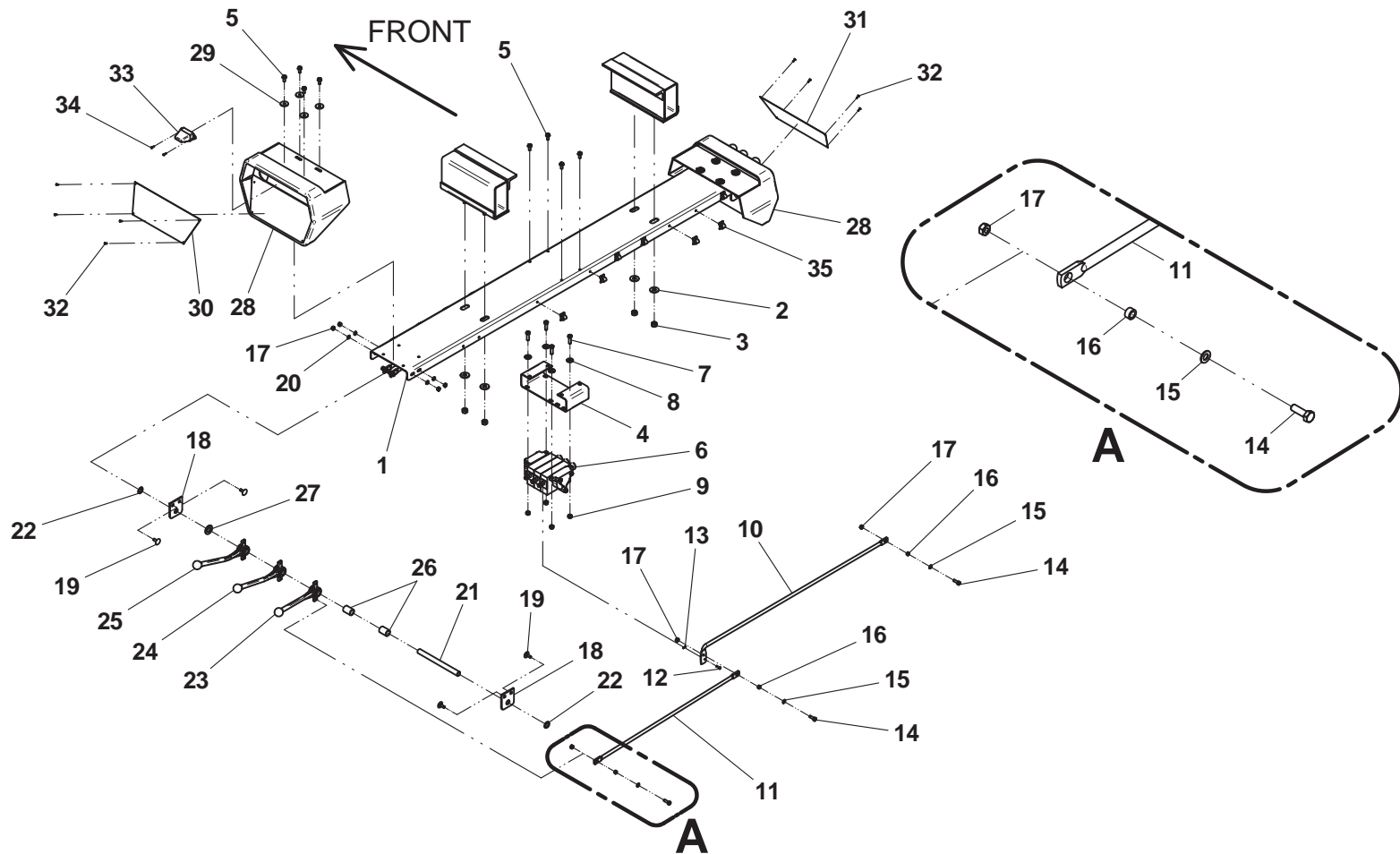

DUAL CONTROLS - 4 BANK

ITEM	PART NO.	DESCRIPTION	QTY	ITEM	PART NO.	DESCRIPTION	QTY
1	4263000431	Channel	1	29	7949000054	Washer, 0.34" ID	8
2	7950180161	Flatwasher, 0.50" ID	4	30	7330000458	Control Panel, LH (stabilizer)	1
3	7660182601	Locknut, 0.50"-13NC	4		7330000456	Control Panel, LH (hydraulic tow option)	
4	4263000430	Channel	1	31	7330000459	Control Panel, RH (stabilizer)	1
5	7790151253	Screw, 0.31"-18NC x 0.75"	12		7330000457	Control Panel, RH (hydraulic tow option)	
6	3935000116	Control Valve	1	32	7759000006	Pop Rivet	8
7	7111161050	Capscrew, 0.38"-16NC x 1.25"	4	33	7590000087	Lamp	2
8	7950160161	Flatwasher, 0.38" ID	4	34	7791060872	Screw, #6 x 0.50"	4
9	7660162601	Locknut, 0.38"-16NC	4	35	7280000007	Wire Clip	11
10	4763000280	Control Rod	4				
11	4763000279	Control Rod	4				
12	7690101200	Clevis Pin	4				
13	7691000056	Cotter Pin	4				
14	7115150850	Capscrew, 0.31"-18NC x 1.00"	12				
15	7949000011	Flatwasher, 0.31" ID	12				
16	4831000069	Spacer	12				
17	7660152601	Locknut, 0.31"-18NC	20				
18	4606000065	Lug	4				
19	7115150664	Carriage Bolt, 0.31"-18NC x 0.75"	8				
20	7950150000	Washer, 0.31" ID	8				
21	4691000141	Pin	2				
22	7754000009	Retaining Ring	4				
23	7551000018	Control Handle	2				
24	7551000020	Control Handle	4				
25	7551000021	Control Handle	2				
26	4211000001	Bushing	2				
27	7950220141	Flatwasher, 0.75" ID	2				
28	7560000003	Control Hood	2				

DUAL CONTROLS - 4 BANK

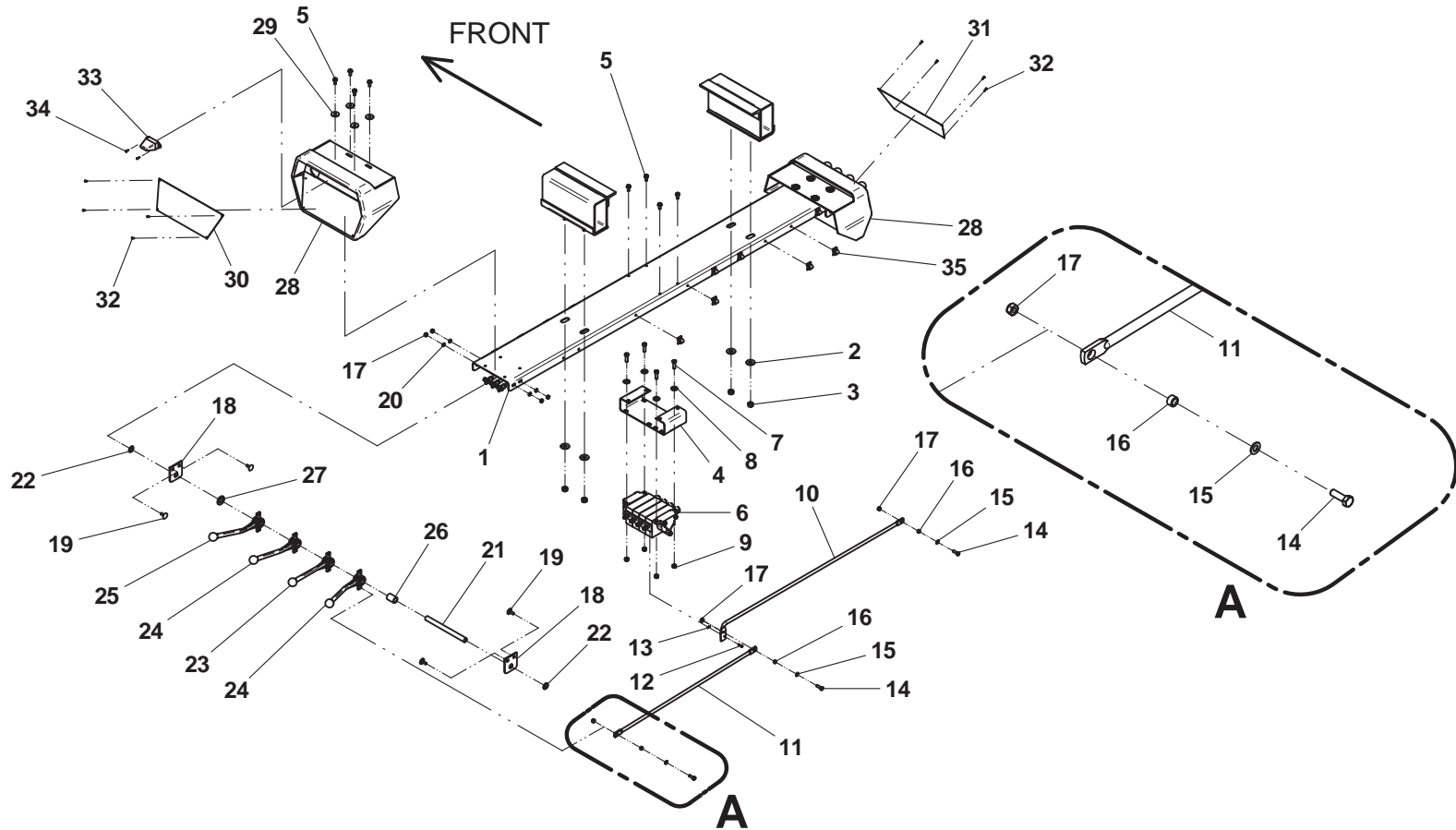

DUAL CONTROLS - 5 BANK

ITEM	PART NO.	DESCRIPTION	QTY	ITEM	PART NO.	DESCRIPTION	QTY
1	4263000431	Channel	1	29	7330000458	Control Panel, LH (stabilizer)	1
2	7950180161	Flatwasher, 0.50" ID	4		7330000456	Control Panel, LH (IRL)	
3	7660182601	Locknut, 0.50"-13NC	4	30	7330000459	Control Panel, RH (stabilizer)	1
4	4263000430	Channel	1		7330000457	Control Panel, RH (IRL)	
5	7790151253	Screw, 0.31"-18NC x 0.75"	12	31	7759000006	Pop Rivet	8
6	3935000117	Control Valve	1	32	7590000087	Lamp	2
7	7111161050	Capscrew, 0.38"-16NC x 1.25"	4	33	7791060872	Screw, #6 x 0.50"	4
8	7950160161	Flatwasher, 0.38" ID	4	34	7280000007	Wire Clip	11
9	7660162601	Locknut, 0.38"-16NC	4				
10	4763000280	Control Rod	5				
11	4763000279	Control Rod	5				
12	7690101200	Clevis Pin	5				
13	7691000056	Cotter Pin	5				
14	7115150850	Capscrew, 0.31"-18NC x 1.00"	15				
15	7949000011	Flatwasher, 0.31" ID	15				
16	4831000069	Spacer	15				
17	7660152601	Locknut, 0.31"-18NC	23				
18	4606000065	Lug	4				
19	7115150664	Carriage Bolt, 0.31"-18NC x 0.75"	8				
20	7950150000	Washer, 0.31" ID	8				
21	4691000141	Pin	2				
	4691000373	Pin (remote winch)					
22	7754000009	Retaining Ring	4				
23	7551000018	Control Handle	2				
24	7551000020	Control Handle	4				
25	7551000021	Control Handle	4				
26	7950220141	Flatwasher, 0.75" ID	2				
27	7560000003	Control Hood	2				
28	7949000054	Washer, 0.34" ID	8				

DUAL CONTROLS - 5 BANK

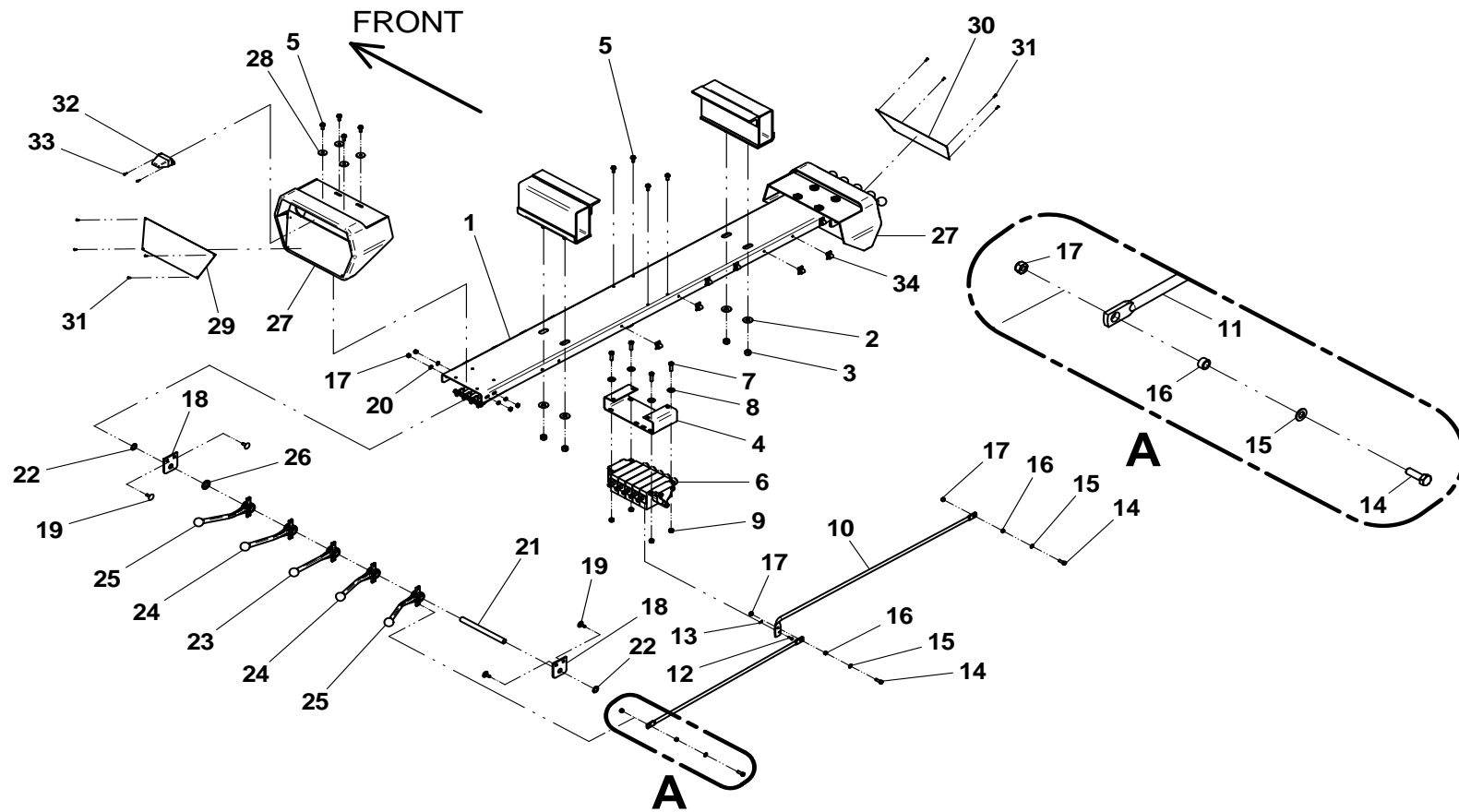

DUAL CONTROLS - 6 BANK

ITEM	PART NO.	DESCRIPTION	QTY	ITEM	PART NO.	DESCRIPTION	QTY
1	4263000431	Channel	1	29	7330000462	Control Panel, LH	1
2	7950180161	Flatwasher, 0.50 ID	4	30	7330000463	Control Panel, RH	1
3	7660182601	Locknut, 0.50-13NC	4	31	7759000006	Pop Rivet	8
4	4263000433	Channel	1	32	7590000087	Lamp	2
5	7790151253	Screw, 0.31-18NC x 0.75	12	33	7791060872	Screw, #6 x 0.50"	4
6	3935000118	Control Valve	1	34	7280000007	Wire Clip	11
7	7111161050	Capscrew, 0.38-16NC x 1.25"	4				
8	7950160161	Flatwasher, 0.38" ID	4				
9	7660162601	Locknut, 0.38"-16NC	4				
10	4763000280	Control Rod	6				
11	4763000279	Control Rod	6				
12	7690101200	Clevis Pin	6				
13	7691000056	Cotter Pin	6				
14	7115150850	Capscrew, 0.31"-18NC x 1.00"	18				
15	7949000011	Flatwasher, 0.31" ID	18				
16	4831000069	Spacer	18				
17	7660152601	Locknut, 0.31"-18NC	26				
18	4606000065	Lug	4				
19	7115150664	Carriage Bolt, 0.31"-18NC x 0.75"	8				
20	7950150000	Washer, 0.31" ID	8				
21	4691000373	Pin	2				
22	7754000009	Retaining Ring	4				
23	7551000019	Control Handle	4				
24	7551000020	Control Handle	4				
25	7551000021	Control Handle	4				
26	7950220141	Flatwasher, 0.75" ID	2				
27	7560000003	Control Hood	2				
28	7949000054	Washer, 0.34" ID	8				

DUAL CONTROLS - 6 BANK

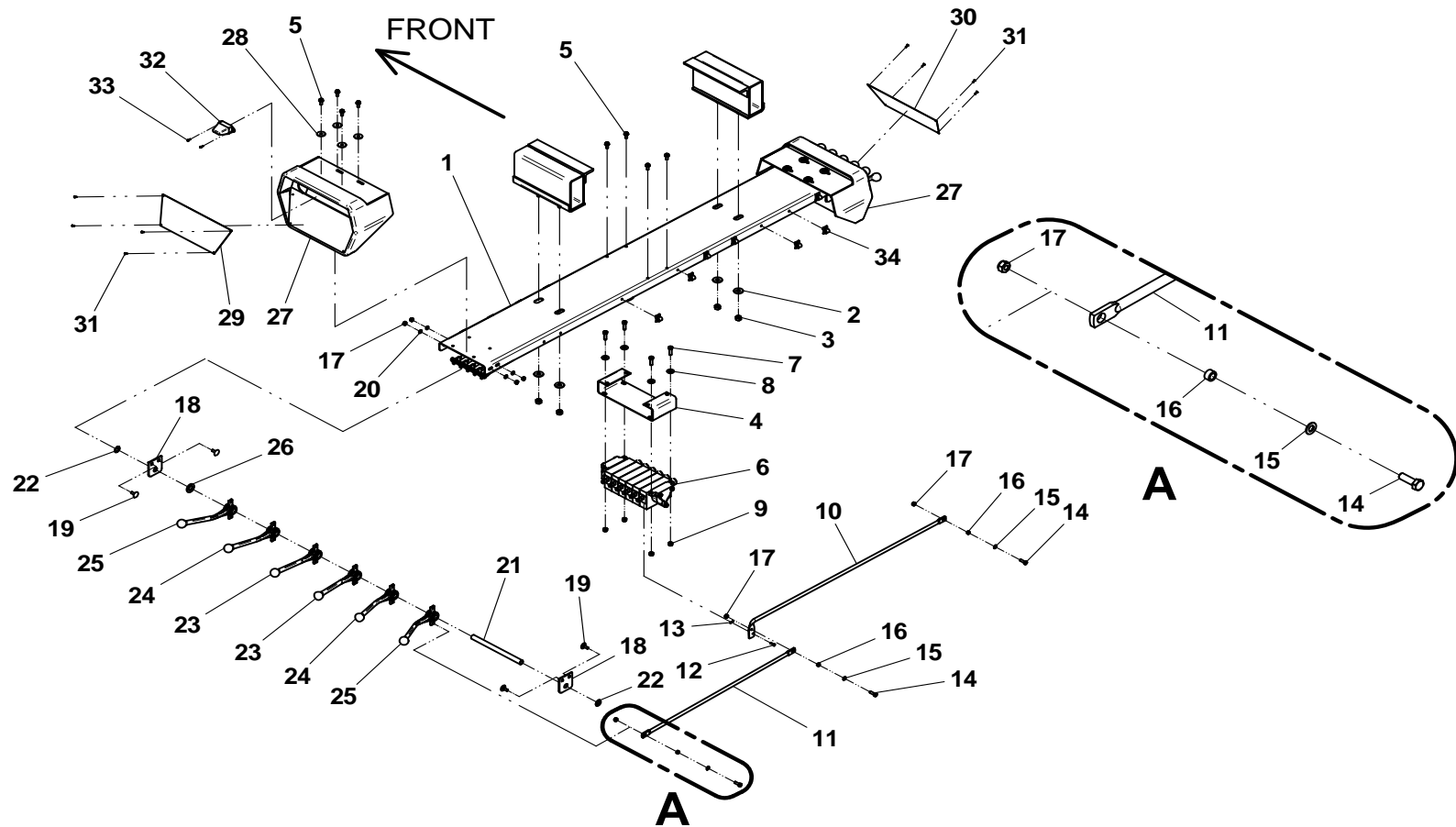

HYDRAULIC COMPONENTS - STANDARD

ITEM	PART NO.	DESCRIPTION	QTY	ITEM	PART NO.	DESCRIPTION	QTY
1	See Note 1	PTO	1	31	4569432122	Hose Assembly	1
2	7724000021	Pump	1	32	4567430133	Hose Assembly (22' deck)	2
3	7115181050	Capscrew, 0.50"-13NC x 1.25"	2		4567430153	Hose Assembly (24' deck)	2
4	7950180000	Lockwasher, 0.50" ID	2		4567430177	Hose Assembly (26' deck)	2
5	7443000101	Adapter	1		4567430199	Hose Assembly (28' deck)	2
6	7445081643	Adapter	1	33	7431000001*	Filter Element	1
7	7443000023	Elbow	1				
8	See Note 1	Supply Hose	1				
9	7443000013	Nipple	1				
10	7274000002	Clamp	2				
11	7430000003	Filter Assembly	1				
12	7470000002	Gauge	1				
13	7443000319	Fitting	1				
14	7274000047	Clamp	2				
15	See Note 1	Return Hose	1				
16	See Note 1	Pressure Hose Assembly	1				
17	7443000168	Adapter	1				
18	7445081045	Elbow	3				
19	Not Required						
20	7445080843	Adapter	2				
21	7445060843	Adapter	4				
22	4567123047	Hose Assembly	1				
23	4567122047	Hose Assembly	1				
24	7445060645	Elbow	5				
25	7445060643	Adapter	3				
26	4567123118	Hose Assembly	1				
27	4567122114	Hose Assembly	1				
28	7935000306	Dual Counterbalance Valve	1				
29	4570000195	Hose Assembly	1				
30	4569433122	Hose Assembly	1				

* also available in Filter Assembly, P/N 7430000003

Note 1: Varies depending on chassis, transmission , PTO type & deck length.
Consult factory for part numbers.

HYDRAULIC COMPONENTS - STANDARD

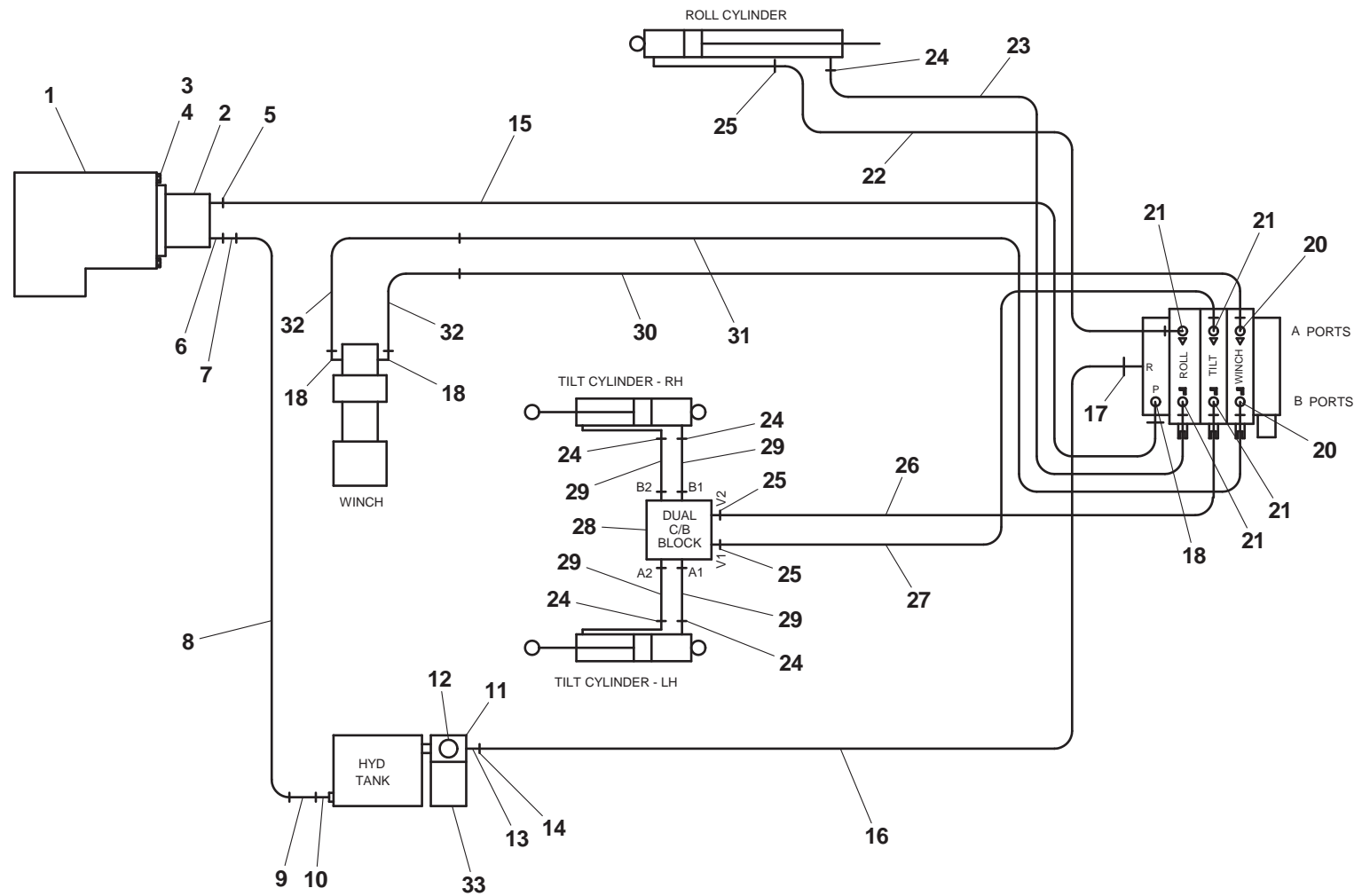

HYDRAULIC COMPONENTS - STANDARD (HOSE TRACK)

ITEM	PART NO.	DESCRIPTION	QTY
1	7904000001	Hose Track	1
2	4706003038	Plate	1
3	7114101618	Capscrew #10-24NC x 2.00"	4
4	7660102604	Locknut, #10-24NC	4
5	7274000038	Clamp	4
6	7274000039	Clamp Cover	2
7	7115151650	Capscrew, 0.31"-18NC x 2.00"	2
8	7950150161	Flatwasher, 0.31" ID	4
9	7660152601	Locknut, 0.31"-13NC (22' deck)	9
	7660152601	Locknut, 0.31"-13NC (24' deck)	10
	7660152601	Locknut, 0.31"-13NC (26' & 28' decks)	12
10	7894000004	Tie Strap (22' deck)	8
	7894000004	Tie Strap (24' deck)	10
	7894000004	Tie Strap (26' & 28' decks)	12
11	7935000197	Counterbalance Valve	1
12	7115151850	Capscrew, 0.31"-18NC x 2.25"	2
13	7274000066	Double Clamp (22' deck)	5
	7274000066	Double Clamp (24' deck)	6
14	7280000013	Clip	*

* Quantity varies depending on deck length and deck type.

HYDRAULIC COMPONENTS - STANDARD (HOSE TRACK)

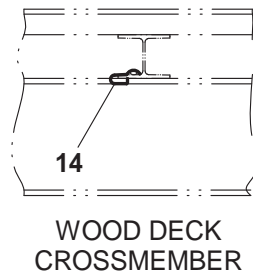
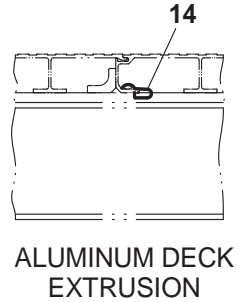
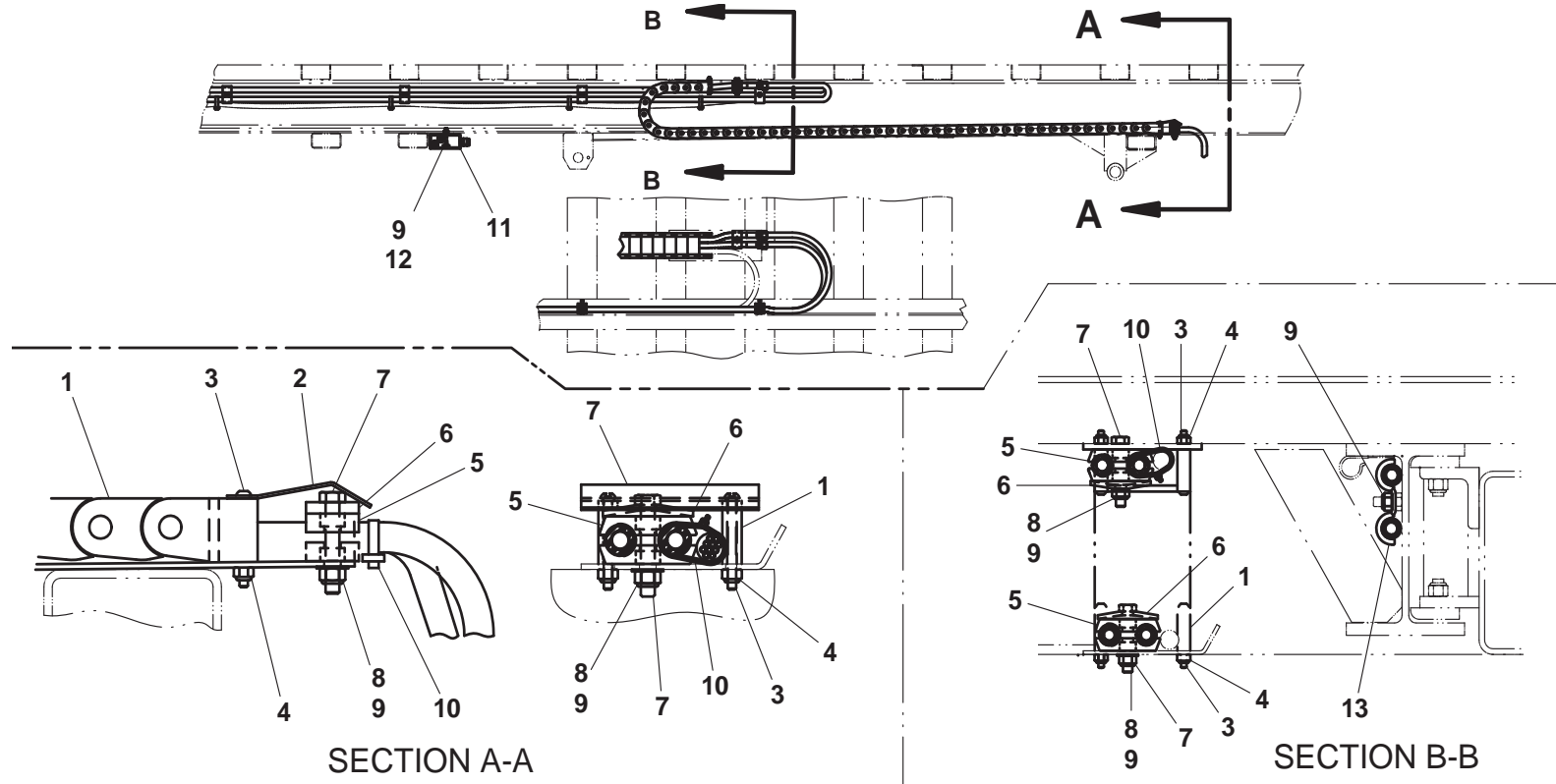

HYDRAULIC COMPONENTS - HOSE ROUTING / MOUNTING

ITEM	PART NO.	DESCRIPTION	QTY
1	7274000076	Cast Frame Clamp	*
2	7785152420	Set Screw, 0.31"-18NC x 1.50"	*
3	7660152601	Locknut, 0.31"-18NC	*
4	7115151050	Capscrew, 0.31"-18NC x 1.25"	*
5	7950150161	Flatwasher, 0.31" ID	*
6	7274000040	Clamp	*
7	7274000041	Clamp	*
8	7274000042	Clamp	*
9	4706003844	Plate	*
10	7115151064	Carriage Bolt, 0.31"-18NC x 1.25"	*

* Quantity varies depending on deck length and deck type

HYDRAULIC COMPONENTS - HOSE ROUTING / MOUNTING

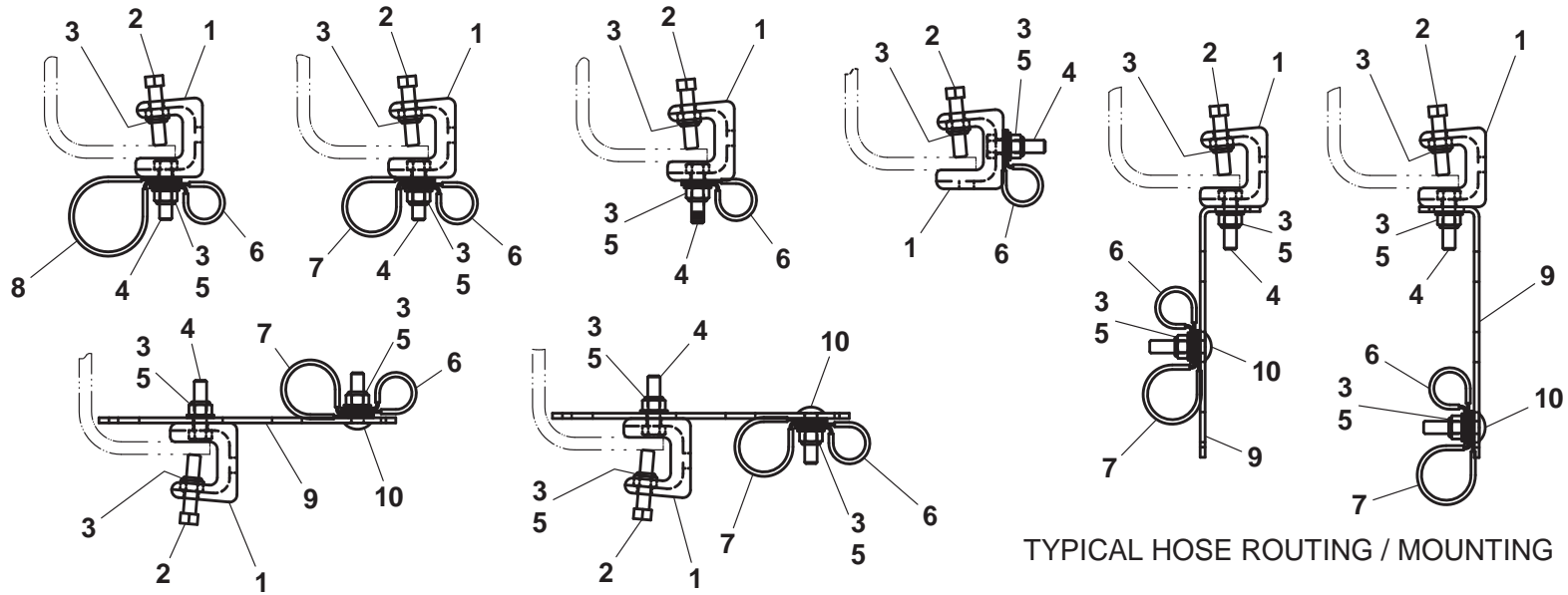
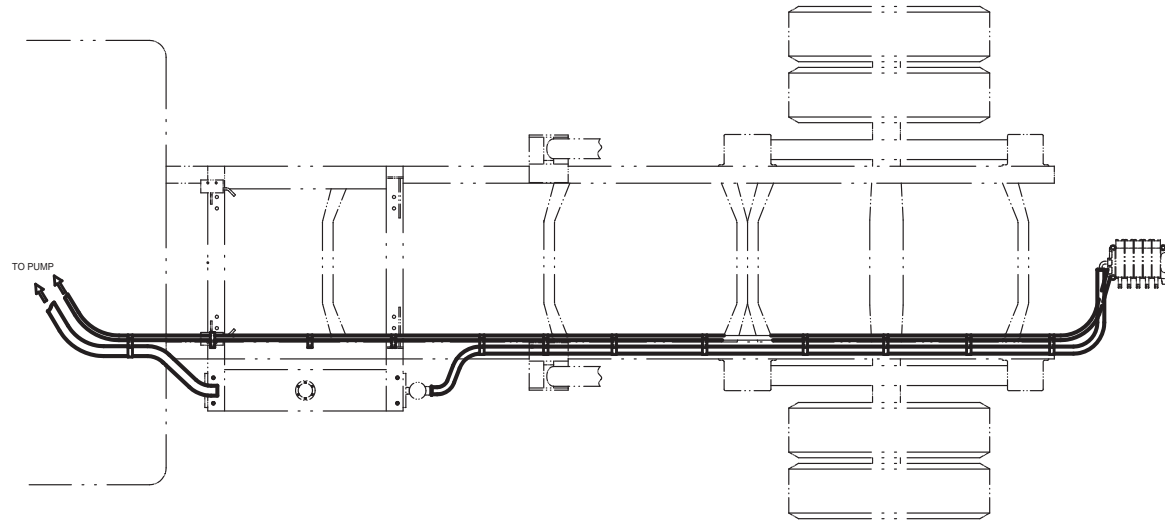

TYPICAL HOSE ROUTING / MOUNTING

HYDRAULIC COMPONENTS - IRL WHEEL LIFT W/ MAN GRIDS OR IRL BALL / PINTLE HITCH MTG PLT

ITEM	PART NO.	DESCRIPTION	QTY
1	7443000129	Reducer	2
2	7445060648	Tee	4
3	4567123045	Hose Assembly	2
4	4567122043	Hose Assembly	2
5	7935000305	Counterbalance Valve	2
6	7445060645	Elbow	4
7	4567122014	Hose Assembly	2
8	7443040643	Adapter	2
9	4567110034	Hose Assembly	2
10	7445040446	Elbow	2

HYDRAULIC COMPONENTS - IRL WHEEL LIFT W/ MAN GRIDS OR IRL BALL / PINTLE HITCH MTG PLT

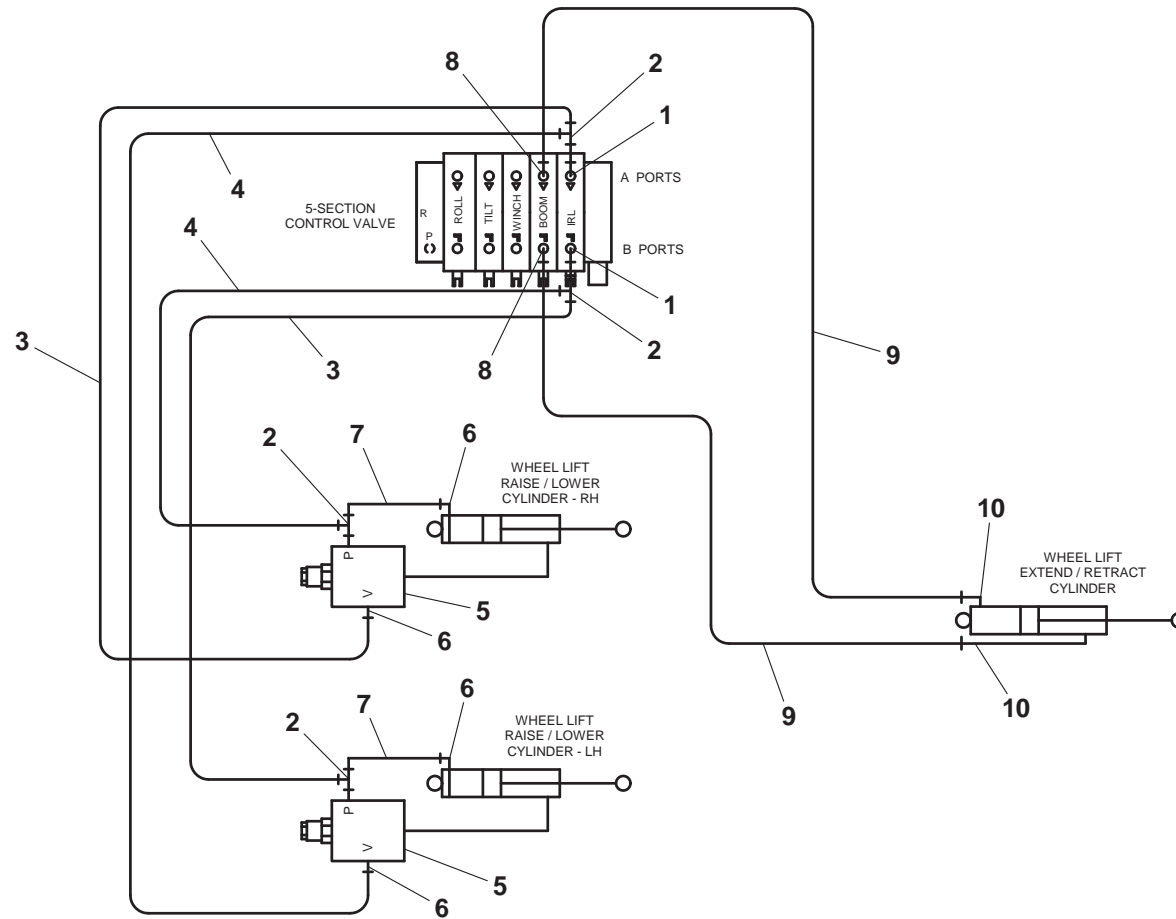

HYDRAULIC COMPONENTS - ZOD WHEEL LIFT WITH MANUAL GRIDS

ITEM	PART NO.	DESCRIPTION	QTY
1	7443000129	Reducer	2
2	7445060648	Tee	4
3	4567123045	Hose Assembly	2
4	4567122043	Hose Assembly	2
5	7935000305	Counterbalance Valve	2
6	7445060645	Elbow	4
7	4567122014	Hose Assembly	2
8	7445060843	Adapter	2
9	4567122030	Hose Assembly	2
10	7445060643	Adapter	4
11	7443040643	Adapter	2
12	4567110034	Hose Assembly	2
13	7445040446	Elbow	2

HYDRAULIC COMPONENTS - ZOD WHEEL LIFT WITH MANUAL GRIDS

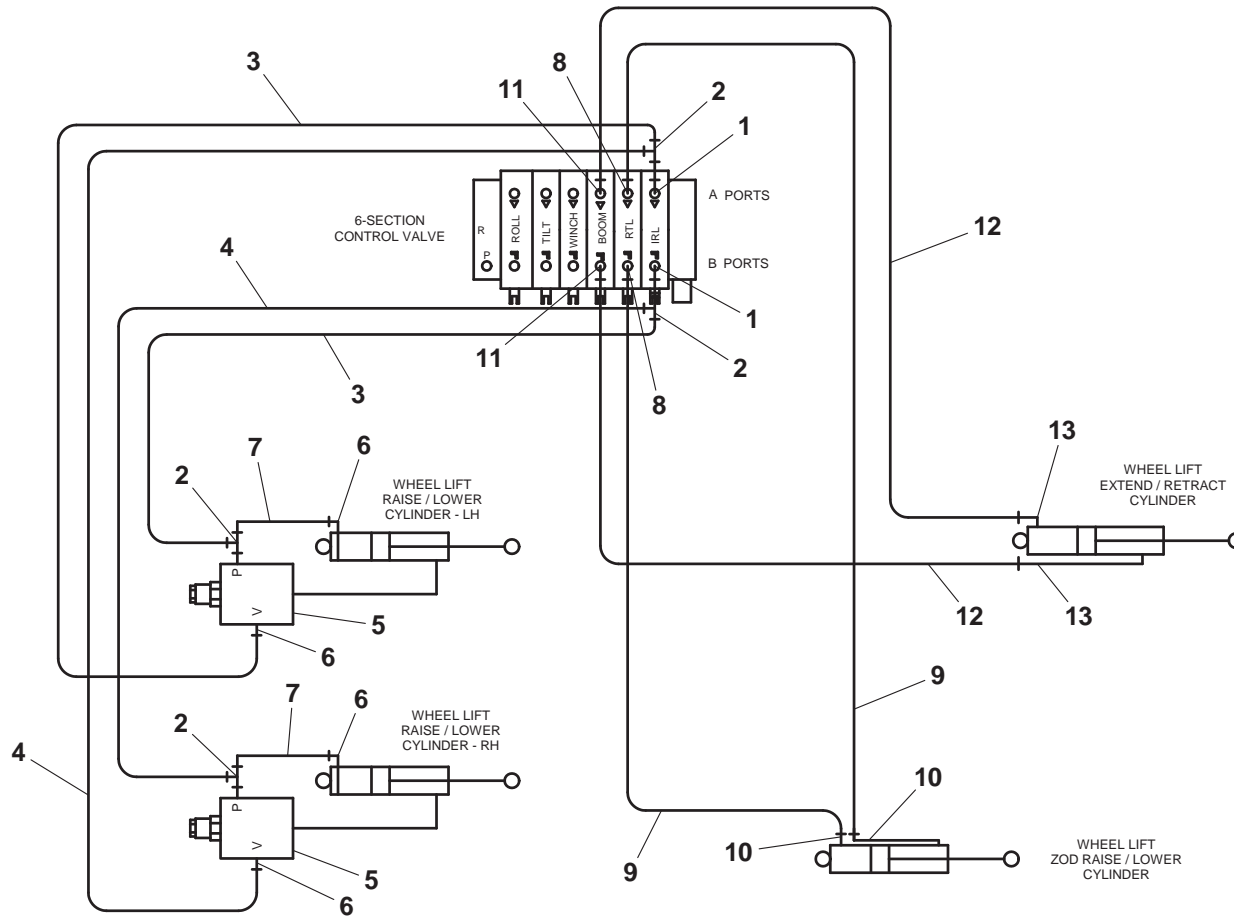

HYDRAULIC COMPONENTS - HYDRAULIC REAR DOCK STABILIZER

ITEM	PART NO.	DESCRIPTION	QTY
1	7445060843	Adapter	2
2	4567122035	Hose Assembly	2
3	7445060637	Tee	2
4	4567120019	Hose Assembly	4
5	7445060645	Elbow	4

HYDRAULIC COMPONENTS - HYDRAULIC REAR DOCK STABILIZER

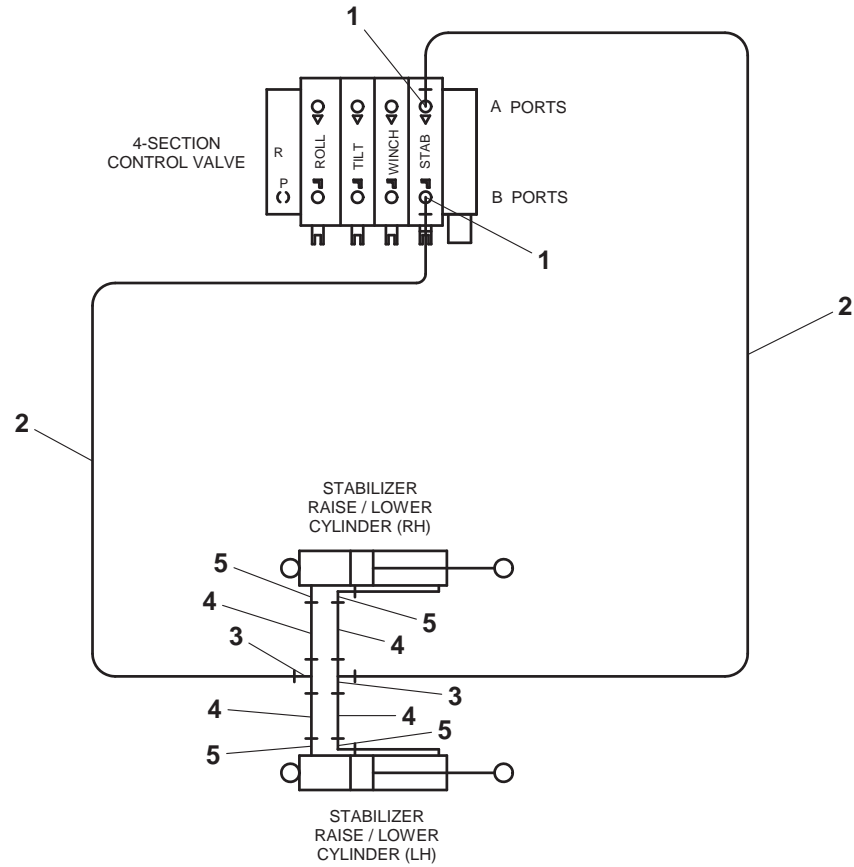

HYDRAULIC COMPONENTS - STABILIZER W/ REESE HITCH RECEIVER OR PINTLE HITCH MTG PLT

ITEM	PART NO.	DESCRIPTION	QTY
1	7445060845	Elbow	2
2	7443000030	Tee	2
3	4567123050	Hose Assembly	2
4	4567122046	Hose Assembly	2
5	7935000305	Counterbalance Valve	2
6	7445060648	Tee	2
7	7445060645	Elbow	4
8	4567122014	Hose Assembly	2

HYDRAULIC COMPONENTS - STABILIZER W/REESE HITCH RECEIVER OR PINTLE HITCH MTG PLT

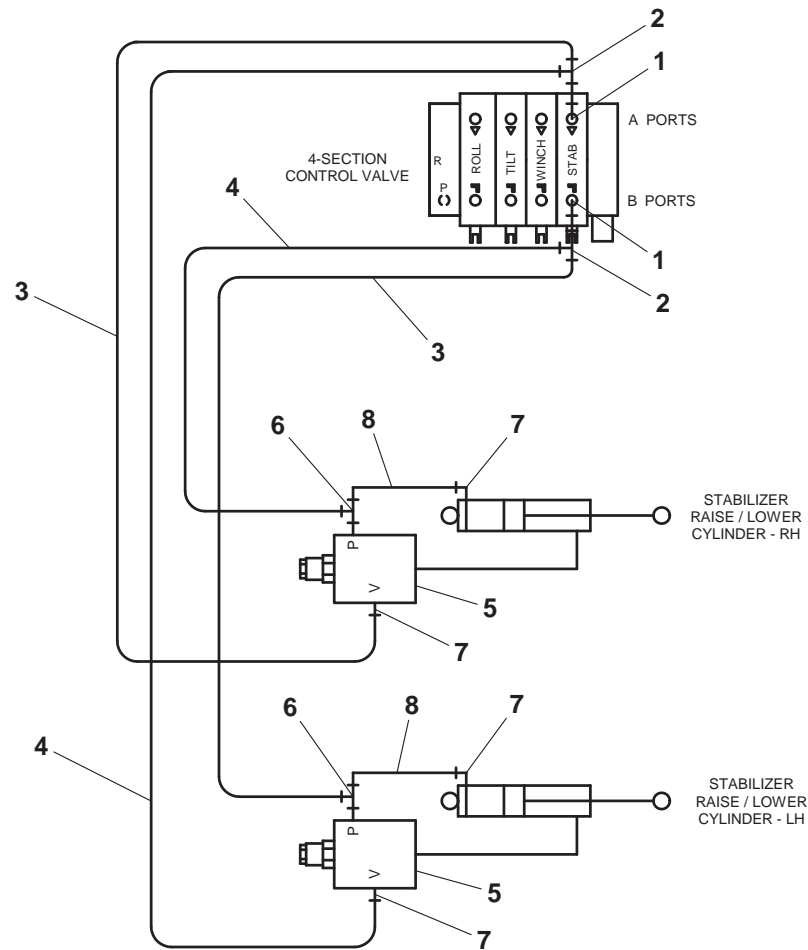

HYDRAULIC COMPONENTS - STABILIZER W/ HYDRAULIC PINTLE HITCH MOUNTING PLATE

ITEM	PART NO.	DESCRIPTION	QTY
1	7445060843	Adapter	2
2	7445060845	Elbow	2
3	7443000030	Tee	2
4	4567123050	Hose Assembly	2
5	4567122046	Hose Assembly	2
6	7935000305	Counterbalance Valve	2
7	7445060645	Elbow	4
8	7445060648	Tee	2
9	4567122014	Hose Assembly	2
10	4567120034	Hose Assembly	2
11	7445060646	Elbow	2

HYDRAULIC COMPONENTS - STABILIZER W/ HYDRAULIC PINTLE HITCH MOUNTING PLATE

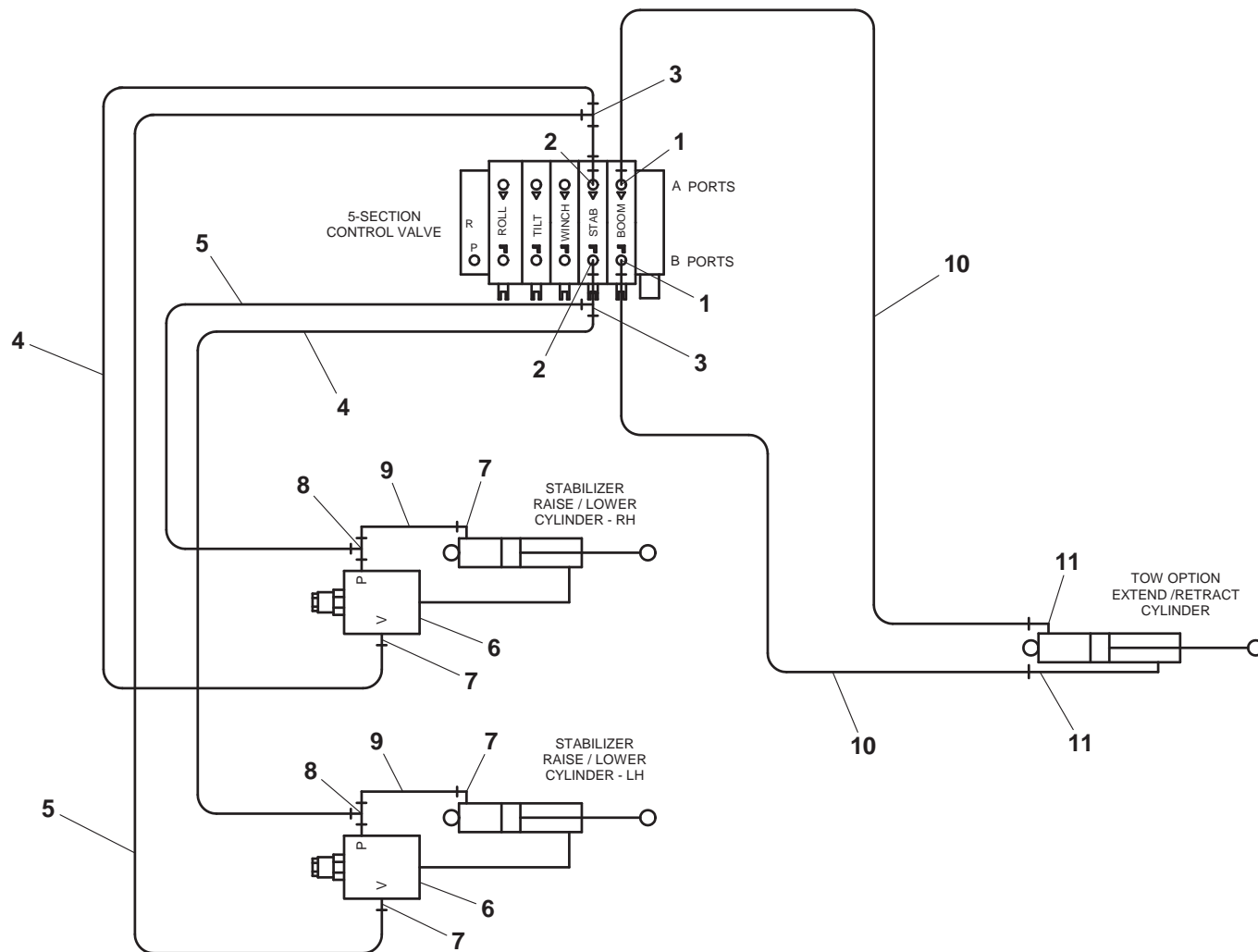

HYDRAULIC COMPONENTS - STABILIZER W/ IRL WHEEL LIFT

ITEM	PART NO.	DESCRIPTION	QTY
1	7443000129	Reducer	2
2	7445060648	Tee	4
3	4567123050	Hose Assembly	2
4	4567122046	Hose Assembly	2
5	7935000305	Counterbalance Valve	2
6	7445060645	Elbow	4
7	4567122014	Hose Assembly	2
8	7445040843	Adapter	2
9	4567110034	Hose Assembly	2
10	7445040445	Elbow	2

HYDRAULIC COMPONENTS - STABILIZER W/ IRL WHEEL LIFT

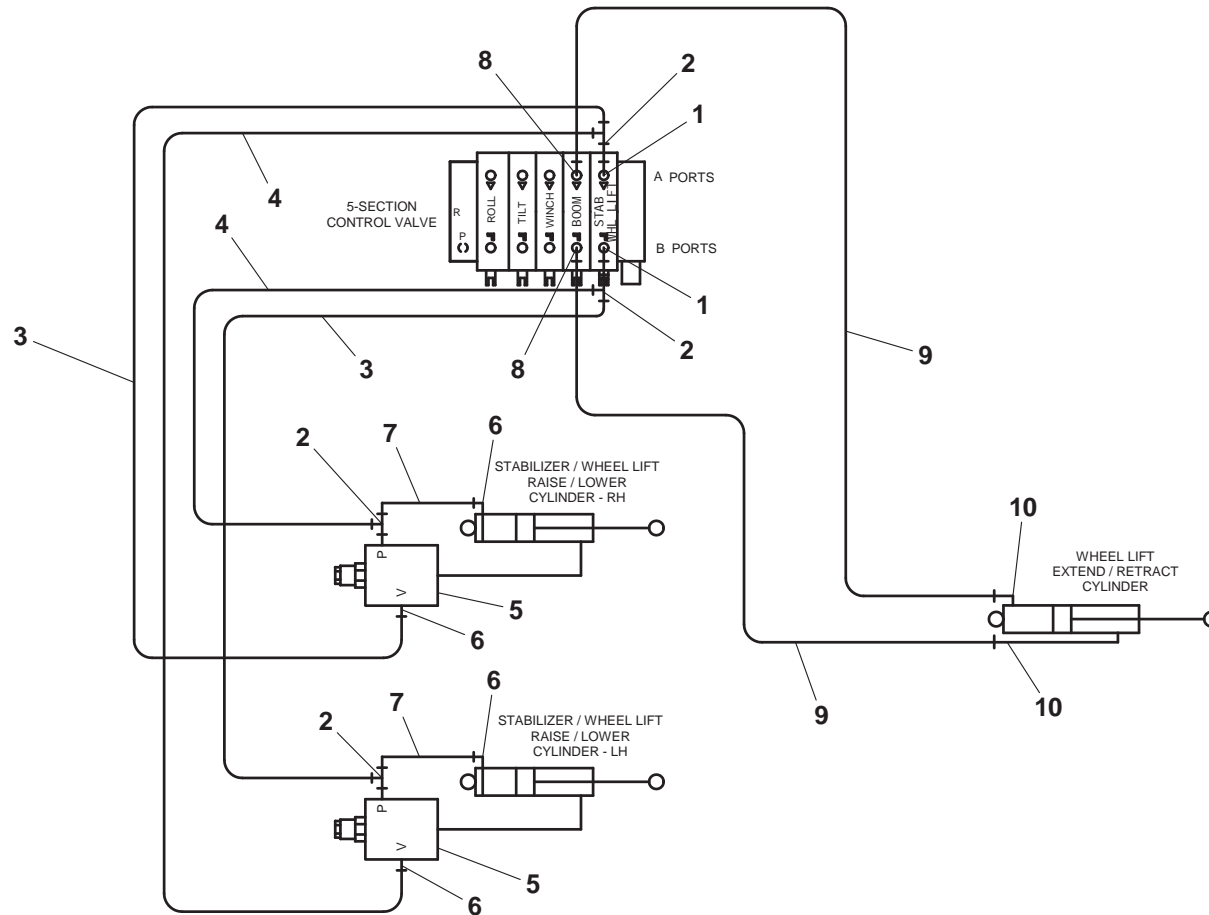

HYDRAULIC COMPONENTS - IRL TOWBAR

ITEM	PART NO.	DESCRIPTION	QTY
1	7445060845	Elbow	2
2	7443000030	Tee	2
3	4567123050	Hose Assembly	2
4	4567122046	Hose Assembly	2
5	7935000305	Counterbalance Valve	2
6	7445060645	Elbow	4
7	4567122014	Hose Assembly	2
8	7443060843	Adapter	2
9	4567122042	Hose Assembly	2
10	7445060643	Adapter	2
11	7445060648	Tee	2

HYDRAULIC COMPONENTS - IRL TOWBAR

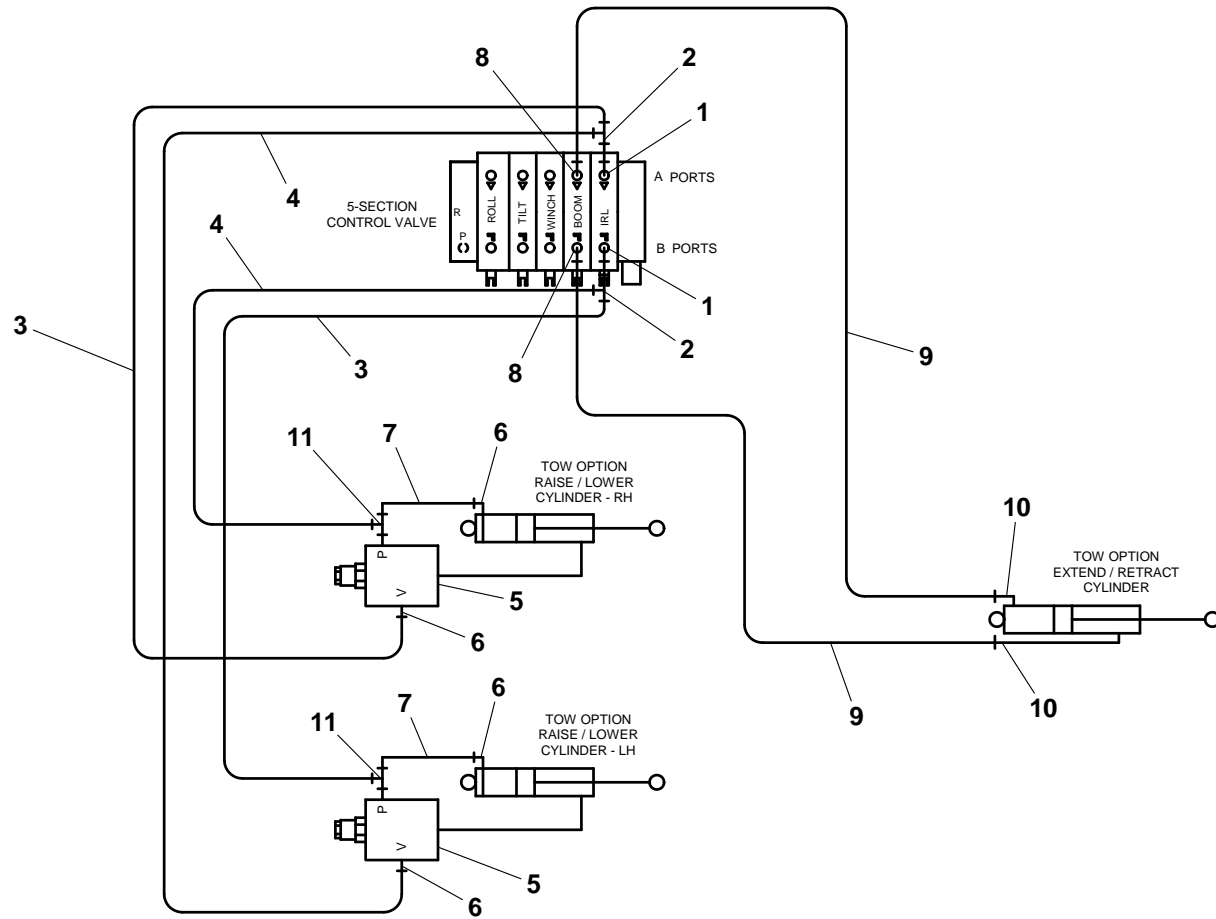

HYDRAULIC COMPONENTS - HYDRAULIC EXTEND TOW OPTION

ITEM	PART NO.	DESCRIPTION	QTY
1	7443060843	Adapter	2
2	4567122042	Hose Assembly	2
3	7445060643	Adapter	2

HYDRAULIC COMPONENTS - HYDRAULIC EXTEND TOW OPTION

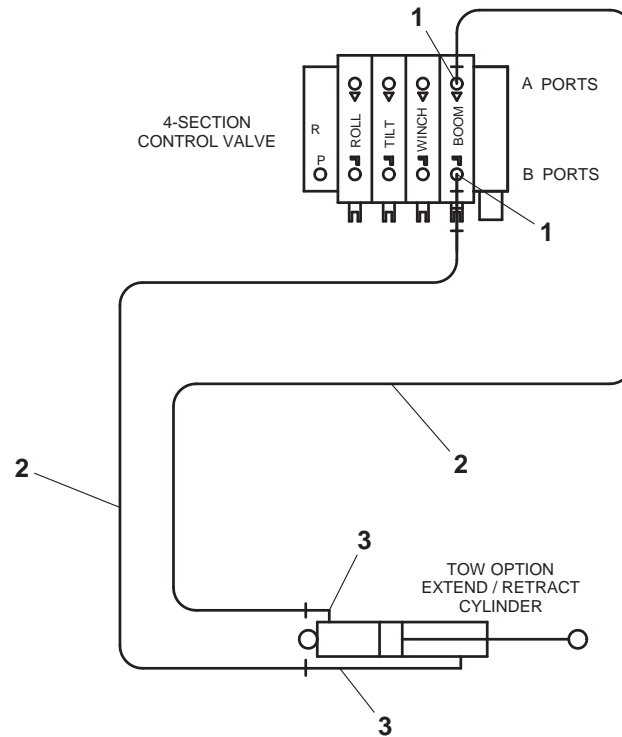

ELECTRICAL COMPONENTS - STANDARD W/ BOLT-ON HEADBOARD (22' & 24' DECKS)

ITEM	PART NO.	DESCRIPTION	QTY
1	7552000098	Subframe to Deck Harness	1
2	7552000074	Subframe to Cab Harness	1
3	7552000135	Subframe Harness	1
4	7552000179	Deck Harness	1
5	7552000166	Winch Lights Harness	1
6	7552000222	Worklights on Headboard Harness	1
7	7345241902	Terminal	1
8	7457000004	Circuit Breaker	1
9	7790100856	Screw, #10 x 0.50"	2
10	7345221902	Terminal	2
11	7950100151	Flatwasher, 0.19" ID	2
12	7280000013	Clip	*
13	3590000015	Wiring Connector Kit (Ford & GMC chassis)	1
	3590000017	Wiring Connector Kit (UD chassis)	

* Quantity varies depending on deck construction.

ELECTRICAL COMPONENTS - STANDARD W/ BOLT-ON HEADBOARD (22' & 24' DECKS)

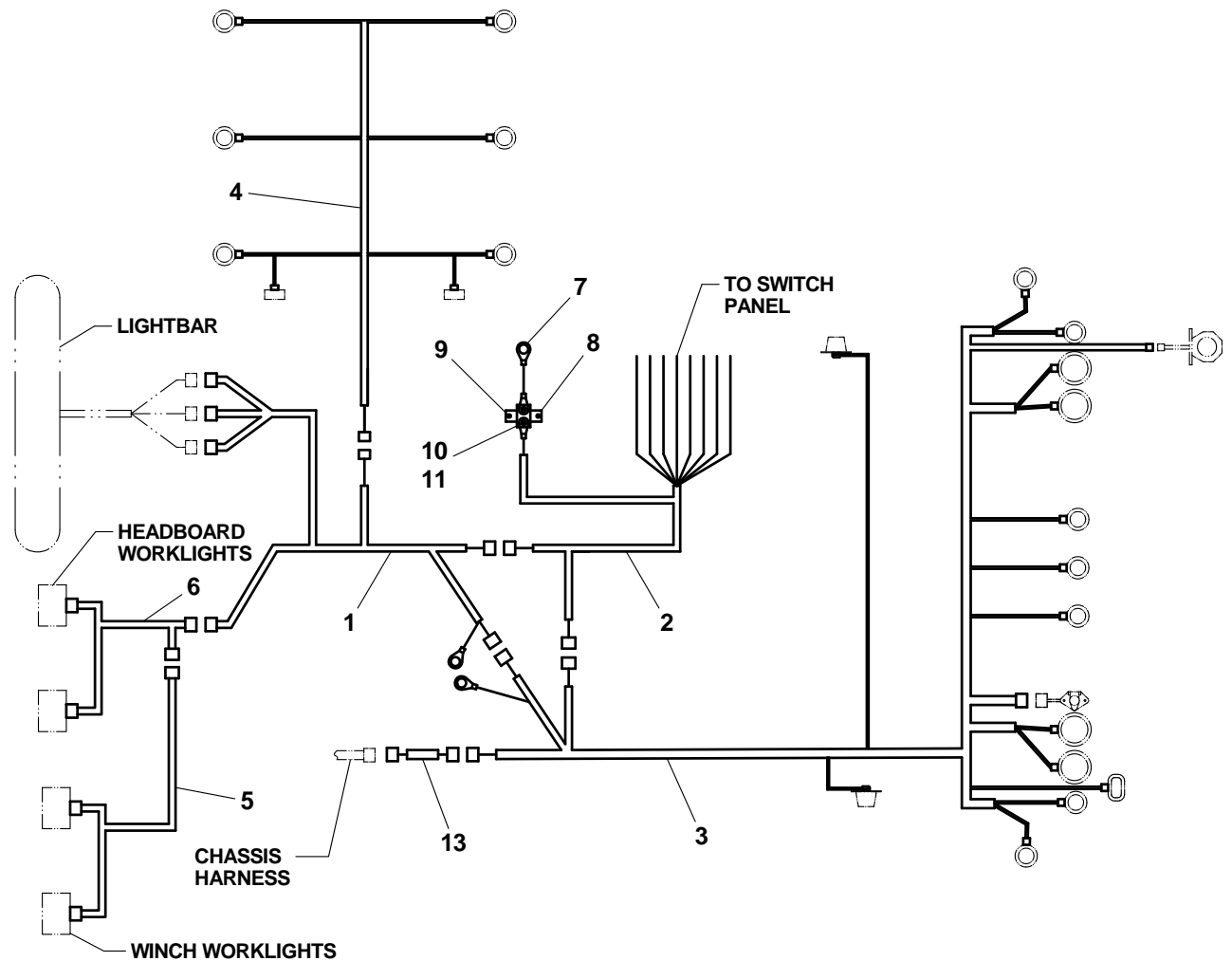

Item #12, Clip, not shown.

ELECTRICAL COMPONENTS - STANDARD W/ BOLT-ON HEADBOARD (26' & 28' DECKS)

ITEM	PART NO.	DESCRIPTION	QTY
1	7552000186	Subframe to Deck Harness	1
2	7552000178	Subframe to Cab Harness	1
3	7552000135	Subframe Harness	1
4	7552000187	Subframe to Deck Aux. Harness	1
5	7552000181	Deck Harness	1
6	7552000166	Winch Lights Harness	1
7	7552000222	Worklights on Headboard Harness	1
8	7345241902	Terminal	1
9	7457000004	Circuit Breaker	1
10	7790100856	Screw, #10 x 0.50"	2
11	7345221902	Terminal	2
12	7950100151	Flatwasher, 0.19" ID	2
13	7280000013	Clip	*
14	3590000015	Wiring Connector Kit (Ford & GMC chassis)	1
	3590000017	Wiring Connector Kit (UD chassis)	

* Quantity varies depending on deck construction.

ELECTRICAL COMPONENTS - STANDARD W/ BOLT-ON HEADBOARD (26' & 28' DECKS)

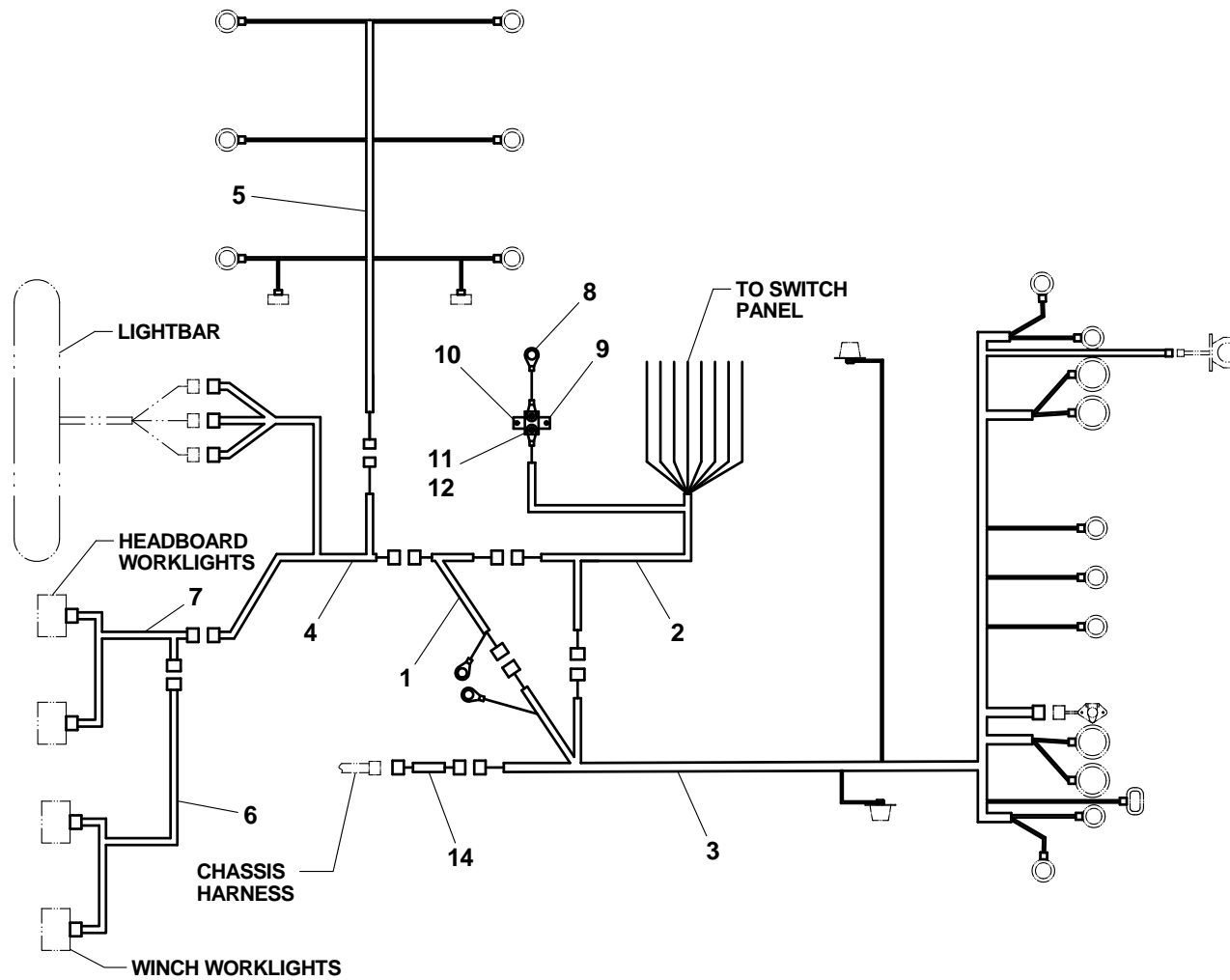

Item #13, Clip, not shown.

ELECTRICAL COMPONENTS - STANDARD W/ STATIONARY HEADBOARD

ITEM	PART NO.	DESCRIPTION	QTY
1	7552000302	Subframe to Cab Harness	1
2	7552000190	Subframe to Deck Harness	1
3	7552000135	Subframe Harness	1
4	7552000179	Deck Harness (22' & 24' decks)	1
	7552000181	Deck Harness (26' & 28' decks)	1
5	7552000191	Subframe to Deck Aux Harness (22' & 24' decks)	1
	7552000192	Subframe to Deck Aux Harness (26' & 28' decks)	
6	7552000166	Worklights on Winch Harness	1
7	7345241902	Terminal	1
8	7457000004	Circuit Breaker	1
9	7790100856	Screw, #10 x 0.50"	2
10	7345221902	Terminal	2
11	7950100151	Flatwasher, 0.19" ID	2
12	7280000013	Clip	*
13	3590000015	Wiring Connector Kit	1

* Quantity varies depending on deck construction.

ELECTRICAL COMPONENTS - STANDARD W/ STATIONARY HEADBOARD

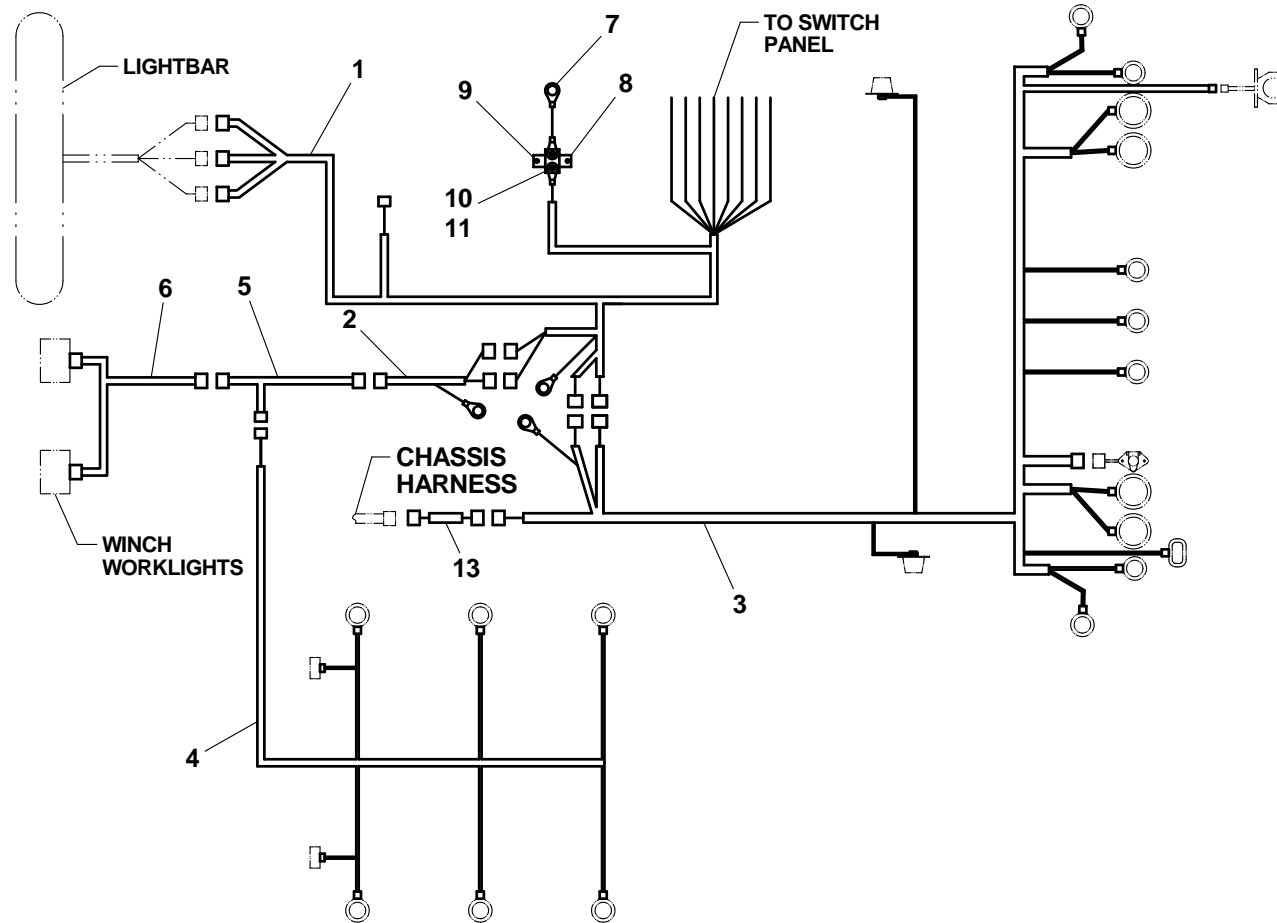

Item #12, Clip, not shown.

ELECTRICAL COMPONENTS - OPTIONAL (TAIL LIGHT CONVERTER)

ITEM	PART NO.	DESCRIPTION	QTY
1	7297000008	Taillight Converter	1
2	4706002990	Plate	1
3	7661000007	Wellnut	4
4	7104100613	Screw, #10-32NF x 0.75"	4
5	7790151253	Screw, 0.31"-18NC x 1.50"	2
6	7345001714	Terminal	5
7	4346000005	Heak Shrink Tubing - 1.50"	5
8	7345221902	Terminal	1
9	7345241902	Terminal	1
10	7346000126	Fuse Holder	1
11	7457000017	Fuse - 30 amp	1
12	7345001914	Terminal	1

ELECTRICAL COMPONENTS - OPTIONAL (TAIL LIGHT CONVERTER)

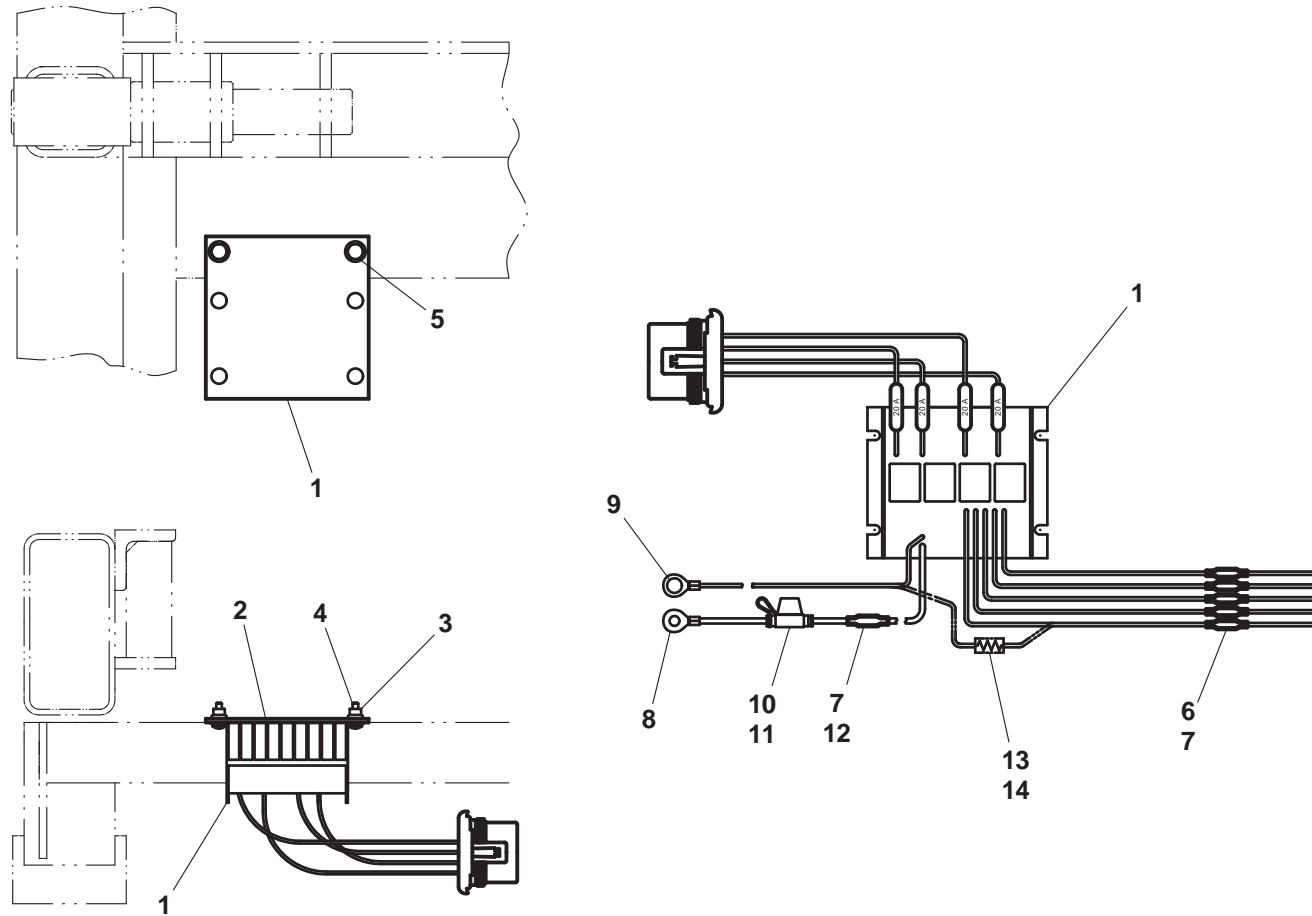

IRL WHEEL LIFT

ITEM	PART NO.	DESCRIPTION	QTY	ITEM	PART NO.	DESCRIPTION	QTY
1	3170000162	Outer Boom Weld (3,000 lb wheel lift)	1	23	7082000016^	Bearing	4
	3170000163	Outer Boom Weld (4,000 lb wheel lift)		24	7291000003	4-Way Receptacle	1
2	3911000056	Inner Boom Weld (3,000 lb wheel lift)	1	25	7796000048	Gasket	1
	3170000304	Inner Boom Weld (4,000 lb wheel lift)		26	7114140528	Screw, 0.25"-20NC x 0.63"	2
3	3320000115	Cylinder Assembly	1	27	7660142601	Locknut, 0.25"-20NC	2
4	4691000296	Pin	1				
5	4691000268	Pin	1				
6	7754000006	Retaining Ring	4				
7	7082000020*	Bushing (3,000 lb wheel lift)	1				
	7082000021<	Bushing (4,000 lb wheel lift)					
8	4679000046	Wear Pad	1				
9	4017000739	Angle	2				
10	7118140418	Capscrew, 0.25"-20NC x 0.50"	4				
11	7950100151	Washer, 0.19" ID	4				
12	4679000211	Wear Pad	1				
13	3320000123	Cylinder Assembly (3,000 lb wheel lift)	2				
	3320000124	Cylinder Assembly (4,000 lb wheel lift)					
14	3691000164	Pin Weld	2				
15	7115160950	Capscrew, 0.38"-16NC x 1.12"	6				
16	7660162601	Locknut, 0.38"-16NC	6				
17	3691000073	Pin Weld	3				
18	3020000101	Arm Weld (3,000 lb wheel lift)	2				
	3020000102	Arm Weld (4,000 lb wheel lift)					
19	7082000017+	Bearing	2				
20	7082000018+	Bearing	2				
21	3592000039	Link Assembly (3,000 lb wheel lift)	1				
	3592000040	Link Assembly (4,000 lb wheel lift)					
22	3691000069	Pin Weld	1				

+ included in Arm Weld, P/Ns 3020000101 & 3020000102

^ included in Link Weld, P/Ns 359 2000034, 3592000041 & 3592000042

< included in Inner Boom Weld, P/N 3911000304

* included in Inner Boom Weld, P/N 3911000056

IRL WHEEL LIFT

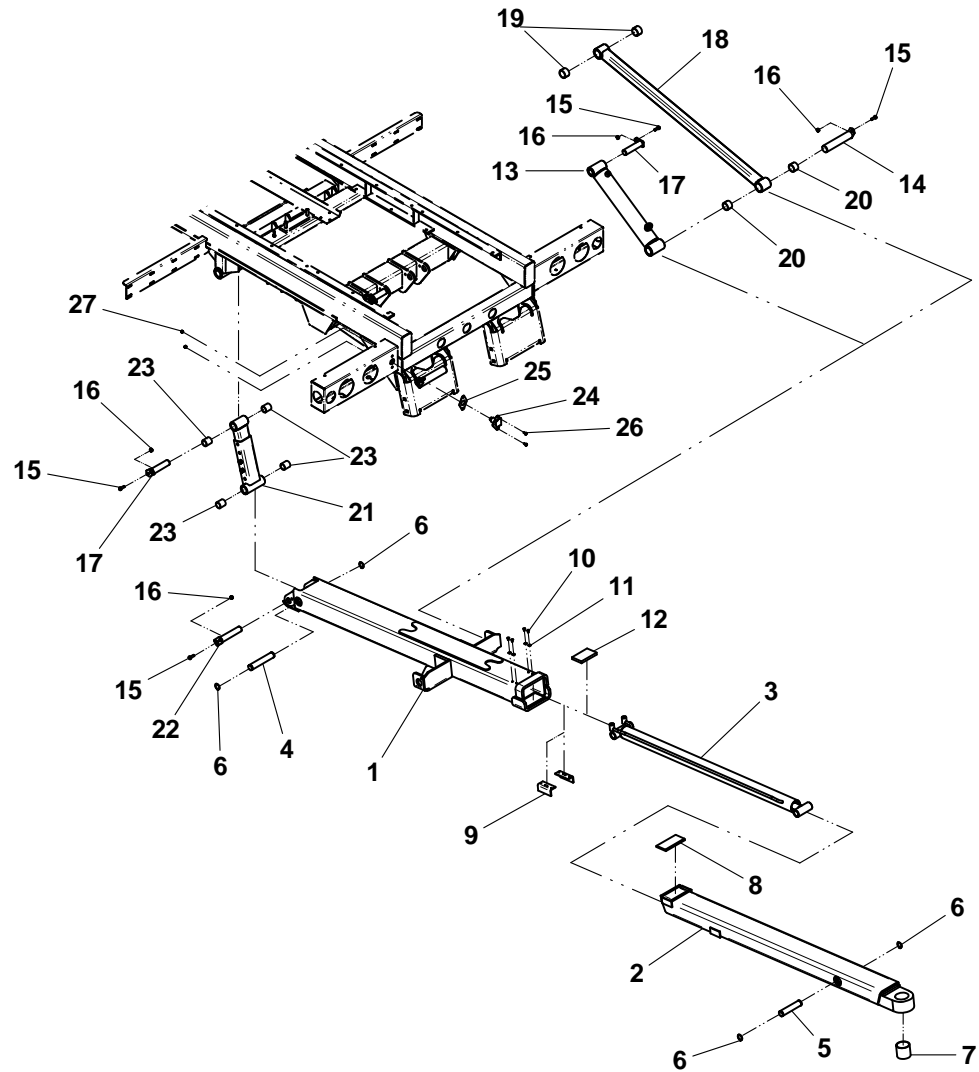

3,000 lb wheel lift shown

ZOD WHEEL LIFT

ITEM	PART NO.	DESCRIPTION	QTY
1	3170000237	Outer Boom Weld	1
2	3911000056	Inner Boom Weld	1
3	3320000115	Cylinder Assembly	1
4	4691000296	Pin	1
5	4691000268	Pin	1
6	7754000006	Retaining Ring	4
7	7082000020*	Bushing	1
8	4679000046	Wear Pad	1
9	4017000739	Angle	2
10	7118140418	Capscrew, 0.25"-20NC x 0.50"	4
11	7950100151	Washer, 0.19" ID	4
12	4679000211	Wear Pad	1
13	3320000123	Cylinder Assembly	2
14	3691000164	Pin Weld	2
15	7115160950	Capscrew, 0.38"-16NC x 1.12"	6
16	7660162601	Locknut, 0.38"-16NC	6
17	3691000073	Pin Weld	3
18	3020000101	Arm Weld	2
19	7082000017+	Bearing	2
20	7082000018+	Bearing	2
21	3320000125	Cylinder Assembly	1
22	3691000069	Pin Weld	1
23	7291000003	4-Way Receptacle	1
24	7796000048	Gasket	1
25	7114140528	Screw, 0.25"-20NC x 0.63"	2
26	7660142601	Locknut, 0.25"-20NC	2

* included in Inner Boom Weld, P/N 3911000056

+ included in Arm Welds, P/Ns 3020000101

ZOD WHEEL LIFT

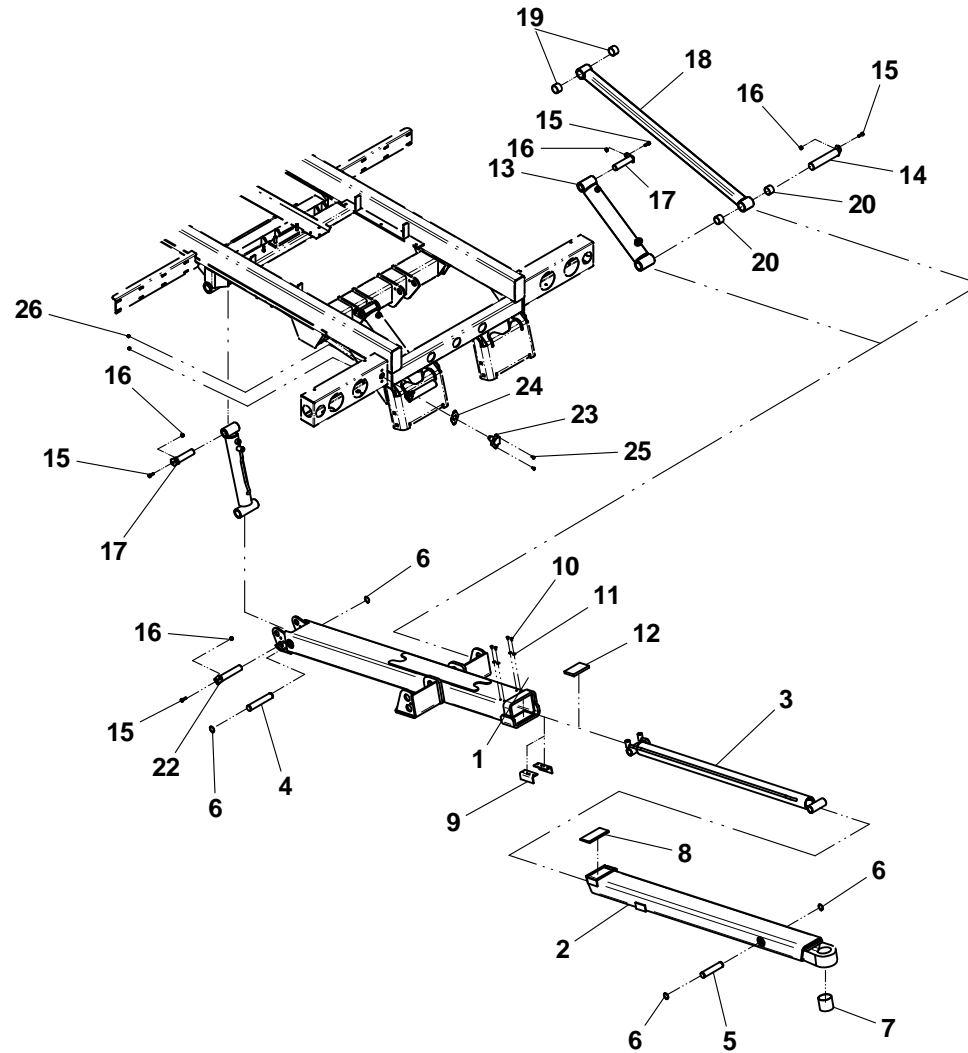

MANUAL L-ARM WHEEL LIFT GRID

ITEM	PART NO.	DESCRIPTION	QTY
1	3913000093	Pivot Tube Weld (3,000 lb IRL wheel lift) (3,000 lb IRL wheel lift w/ ball plate)	1
	3913000096	Pivot Tube Weld (3,000 lb ZOD wheel lift w/ ball plate)	
	3913000097	Pivot Tube Weld (4,000 lb IRL wheel lift w/ ball plate)	
	3913000098	Pivot Tube Weld (3,000 lb IRL wheel lift w/ 2" pintle)	
	3913000099	Pivot Tube Weld (3,000 lb ZOD wheel lift w/ 2" pintle)	
	3913000100	Pivot Tube Weld (4,000 lb IRL wheel lift w/ 2" pintle)	
	3913000101	Pivot Tube Weld (4,000 lb IRL wheel lift w/ 2.5" pintle)	
2	3484000035	Grid Weld - LH (3,000 lb IRL & ZOD wheel lift)	1
	3484000031	Grid Weld - LH (4,000 lb IRL wheel lift)	
3	3484000034	Grid Weld - RH (3,000 lb IRL & ZOD wheel lift)	1
	3484000030	Grid Weld - RH (4,000 lb IRL wheel lift)	
4	4691000447	Pivot Pin (3,000 lb IRL & ZOD wheel lift)	1
	4691000427	Pivot Pin (4,000 lb IRL wheel Lift)	
5	4949000047	Washer	2
6	7754000024	Retaining Ring	1
7	3551000036	T-Handle	2
8	3020000072	L-Arm Weld (3,000 lb IRL & ZOD wheel lift)	1
	3020000037	L-Arm Weld (4,000 lb IRL wheel lift)	
9	7701000062	Plug (3,000 lb IRL & ZOD wheel lift)	2
10	3551000011	Cam Lock Assembly	2
11	7440030000	Grease Fitting	2
12	7330000419	Reflective Tape	2
13	7330000417	Reflective Tape - LH	1
14	7330000418	Reflective Tape - RH	1
15	3020000072	L-Arm Weld (3,000 lb IRL & ZOD wheel lift)	1
	3020000038	L-Arm Weld (4,000 lb IRL wheel lift)	

MANUAL L-ARM WHEEL LIFT GRID

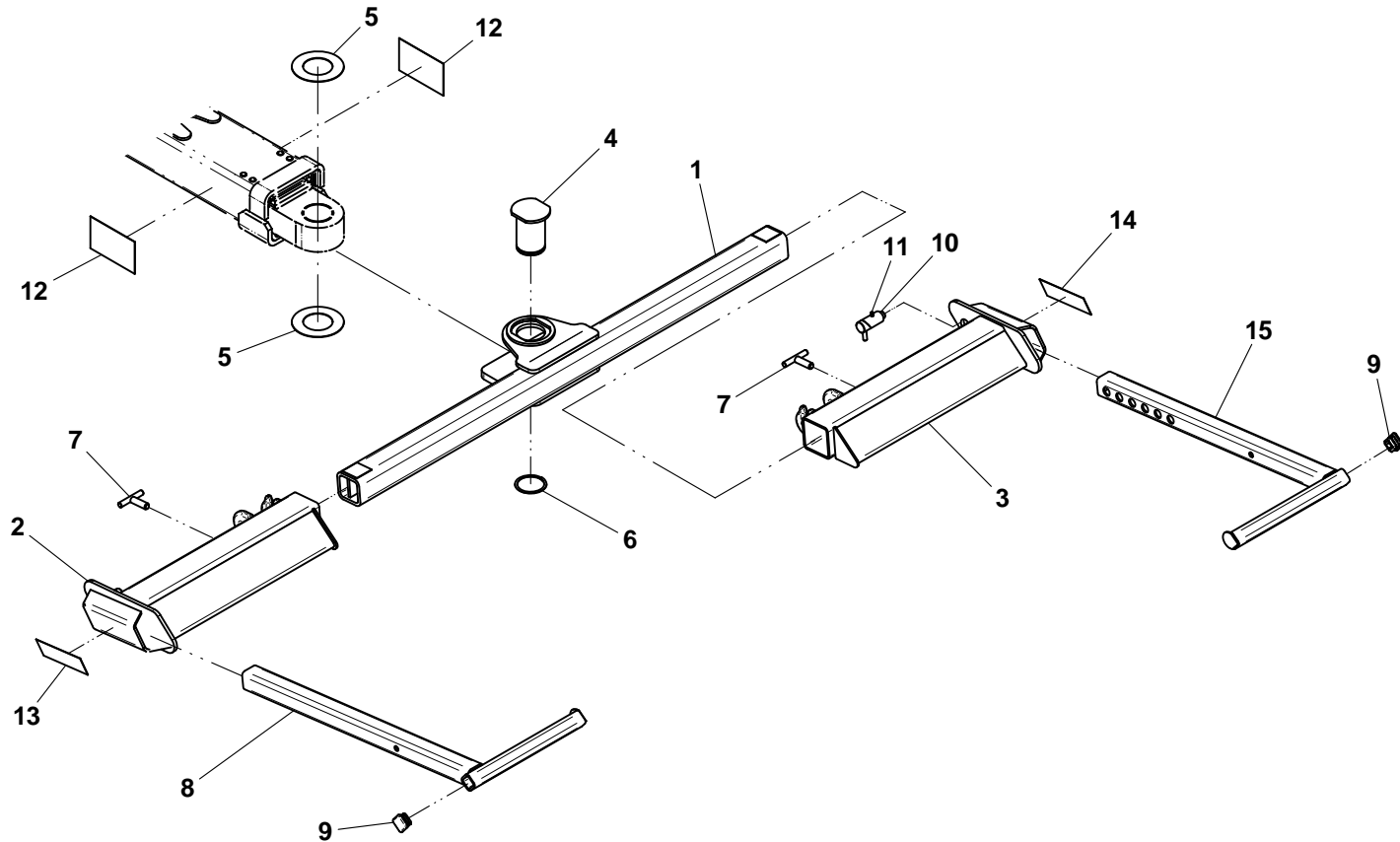

3,000 lb IRL & ZOD wheel lift grid shown

MANUAL T37 PIVOTING WHEEL LIFT GRID

ITEM	PART NO.	DESCRIPTION	QTY	ITEM	PART NO.	DESCRIPTION	QTY
1	3913000093	Pivot Tube Weld (3,000 lb IRL wheel lift) (3,000 lb IRL wheel lift w/ ball plate)	1	16	4691000183~	Pin	2
	3913000096	Pivot Tube Weld (3,000 lb ZOD wheel lift w/ ball plate)		17	4691000447	Pivot Pin (3,000 lb IRL & ZOD wheel lift)	1
	3913000097	Pivot Tube Weld (4,000 lb IRL wheel lift w/ ball plate)		18	4691000427	Pivot Pin (4,000 lb IRL wheel Lift)	
	3913000098	Pivot Tube Weld (3,000 lb IRL wheel lift w/ 2" pintle)		19	4949000047	Washer	2
	3913000099	Pivot Tube Weld (3,000 lb ZOD wheel lift w/ 2" pintle)		20	7754000024	Retaining Ring	1
	3913000100	Pivot Tube Weld (4,000 lb IRL wheel lift w/ 2" pintle)		21	7440030000	Grease Fitting	6
	3913000101	Pivot Tube Weld (4,000 lb IRL wheel lift w/ 2.5" pintle)		22	3020000029	L-Arm Weld - LH	1
2	3484000051*	Grid Weld - LH (3,000 lb IRL & ZOD wheel lift)	1	23	3020000030	L-Arm Weld - RH	1
	3484000017^	Grid Weld - LH (4,000 lb IRL wheel lift)		24	7330000419	Reflective Tape	2
3	3484000050+	Grid Weld - RH (3,000 lb IRL & ZOD wheel lift)	1	25	7330000420	Reflective Tape	1
	3484000016>	Grid Weld - RH (4,000 lb IRL wheel lift)		26	7330000432	Reflective Tape	1
4	4259000002*^	Pivot Casting, LH	1		7950200000	Lockwasher, 0.63" ID	2
5	4259000001+>	Pivot Casting, RH	1				
6	4691000354~	Pin	2				
7	4691000357~	Pin	2				
8	7754000037~	Retaining Ring	2				
9	3551000036	T-Handle	2				
10	4691000186~	Pin	2				
11	7843000006~	Spring	2				
12	4763000184~	Rod	2				
13	4254000005~	Cap	2				
14	7786000006~	Screw	2				
15	7843000016~	Spring	2				

* also available in Grid Assembly, LH, P/N 3484000053

+ also available in Grid Assembly, RH, P/N 3484000052

~ also available in Grid Assembly, P/N's 3484000046, 3484000047, 3484000052 & 3484000053

^ also available in Grid Assembly, LH, P/N 3484000047

> also available in Grid Assembly, RH, P/N 3484000046

MANUAL T37 PIVOTING WHEEL LIFT GRID

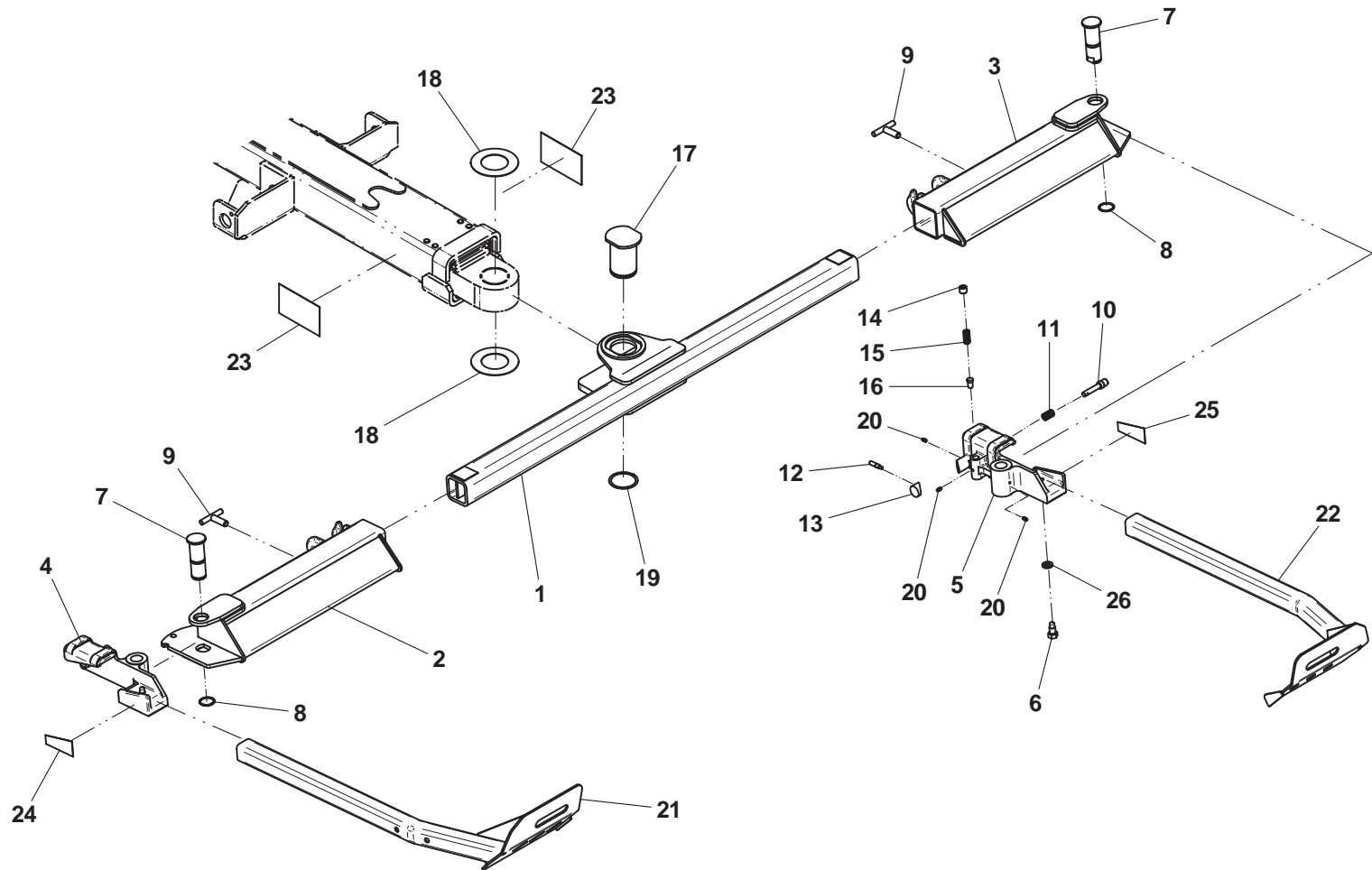

3,000 lb IRL & ZOD wheel lift grid shown

HYDRAULIC REAR DOCK STABILIZER

ITEM	PART NO.	DESCRIPTION	QTY
1	3849000027	Stabilizer Weld	1
2	3320000126	Cylinder Assembly	2
3	3691000165	Pin Weld	2
4	3691000073	Pin Weld	2
5	7115160950	Capscrew, 0.38"-16NC x 1.12"	4
6	7660162601	Locknut, 0.38"-16NC	4
7	7082000017*	Bearing	4

* included in Stabilizer Weld, P/N 3849000027

HYDRAULIC REAR DOCK STABILIZER

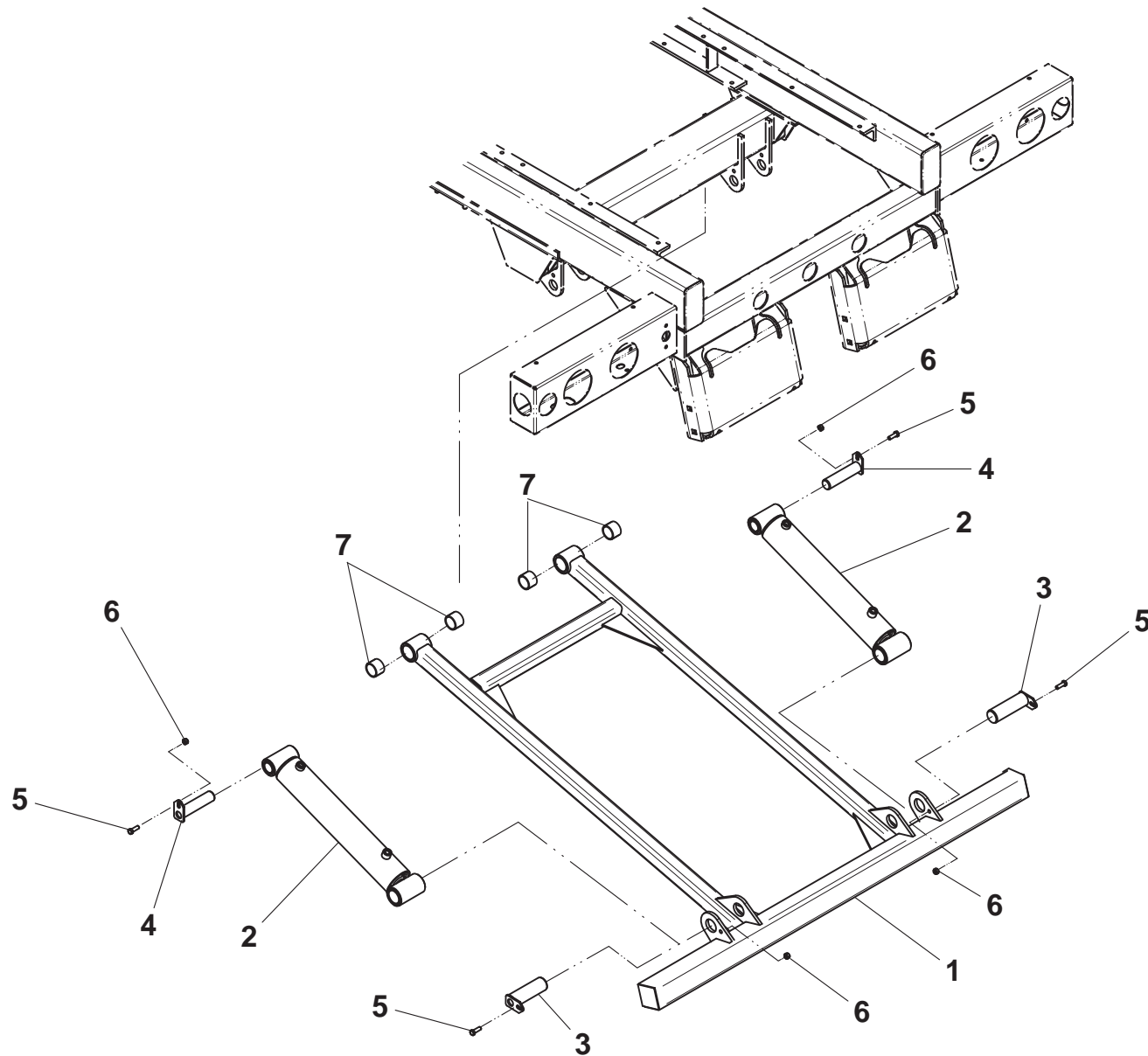

HYDRAULIC REAR DOCK STABILIZER WITH REESE HITCH RECEIVER

ITEM	PART NO.	DESCRIPTION	QTY
1	3849000029	Stabilizer Weld w/ Reese Hitch Receiver	1
2	3320000123	Cylinder Assembly	2
3	3691000165	Pin Weld	2
4	3691000073	Pin Weld	2
5	7115160950	Capscrew, 0.38"-16NC x 1.12"	4
6	7660162601	Locknut, 0.38"-16NC	4
7	7082000017*	Bearing	4
8	7291000003	4-Way Receptacle	1
9	7796000048	Gasket	1
10	7114140528	Screw, 0.25"-20NC x .63"	2
11	7660142601	Locknut, 0.25"-20NC	2

* included in Stabilizer Weld, P/N 3849000029

HYDRAULIC REAR DOCK STABILIZER WITH REESE HITCH RECEIVER

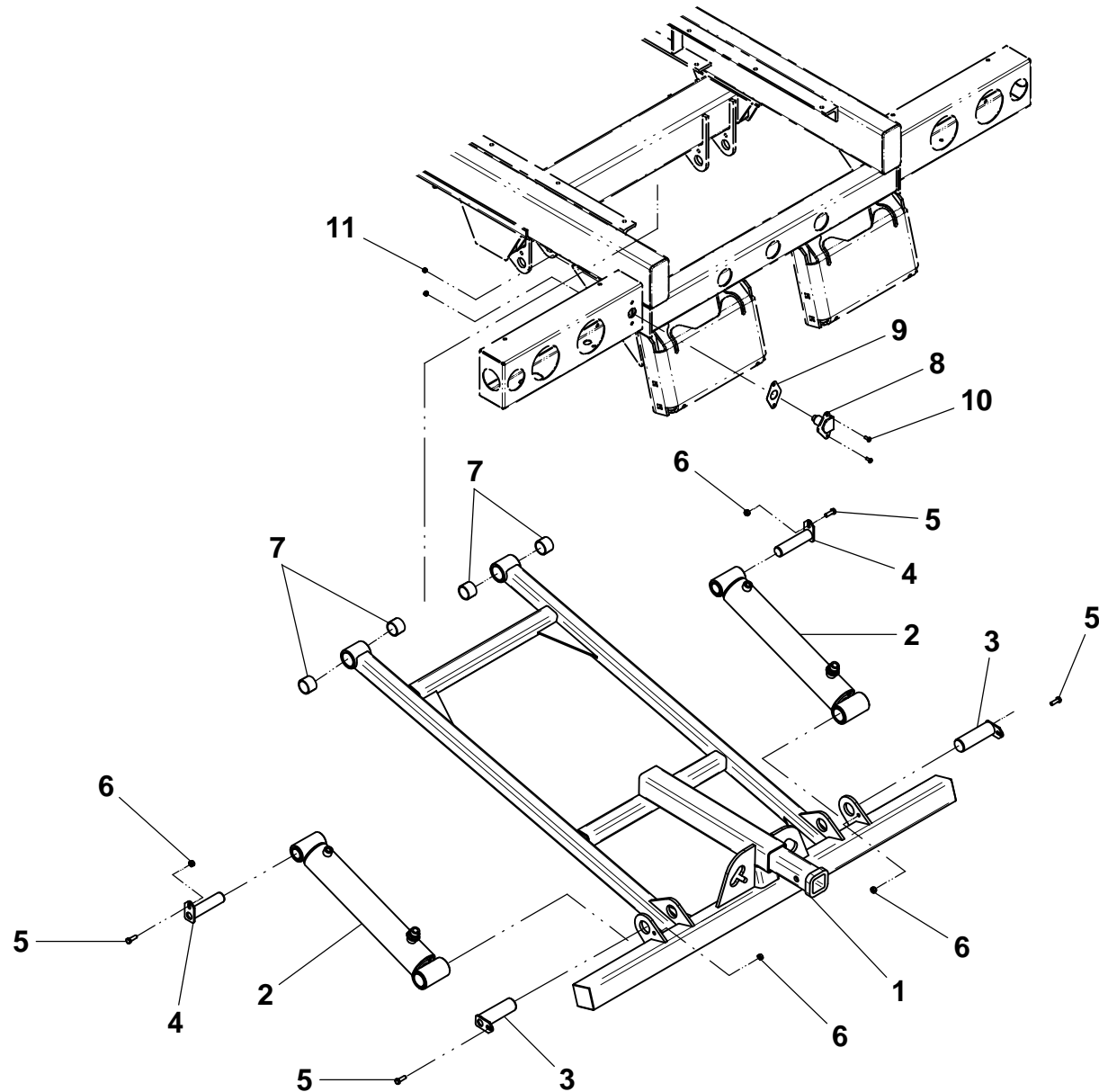

HYDRAULIC REAR DOCK STABILIZER WITH MANUAL EXTEND PINTLE MOUNTING PLATE

ITEM	PART NO.	DESCRIPTION	QTY
1	3849000028	Stabilizer Weld w/ Manual Pintle Plate	1
2	3320000123	Cylinder Assembly	2
3	3691000165	Pin Weld	2
4	3691000073	Pin Weld	2
5	7115160950	Capscrew, 0.38"-16NC x 1.12"	4
6	7660162601	Locknut, 0.38"-16NC	4
7	3170000203	Inner Boom Weld	1
8	3691000064	Pin Weld	1
9	7691000001	Hair Pin	1
10	7082000017*	Bearing	4
11	7291000003	4-Way Receptacle	1
12	7796000048	Gasket	1
13	7114140528	Screw, 0.25"-20NC x 0.63"	2
14	7660142601	Locknut, 0.25"-20NC	2

* included in Stabilizer Weld, P/N 3849000028

HYDRAULIC REAR DOCK STABILIZER WITH MANUAL EXTEND PINTLE MOUNTING PLATE

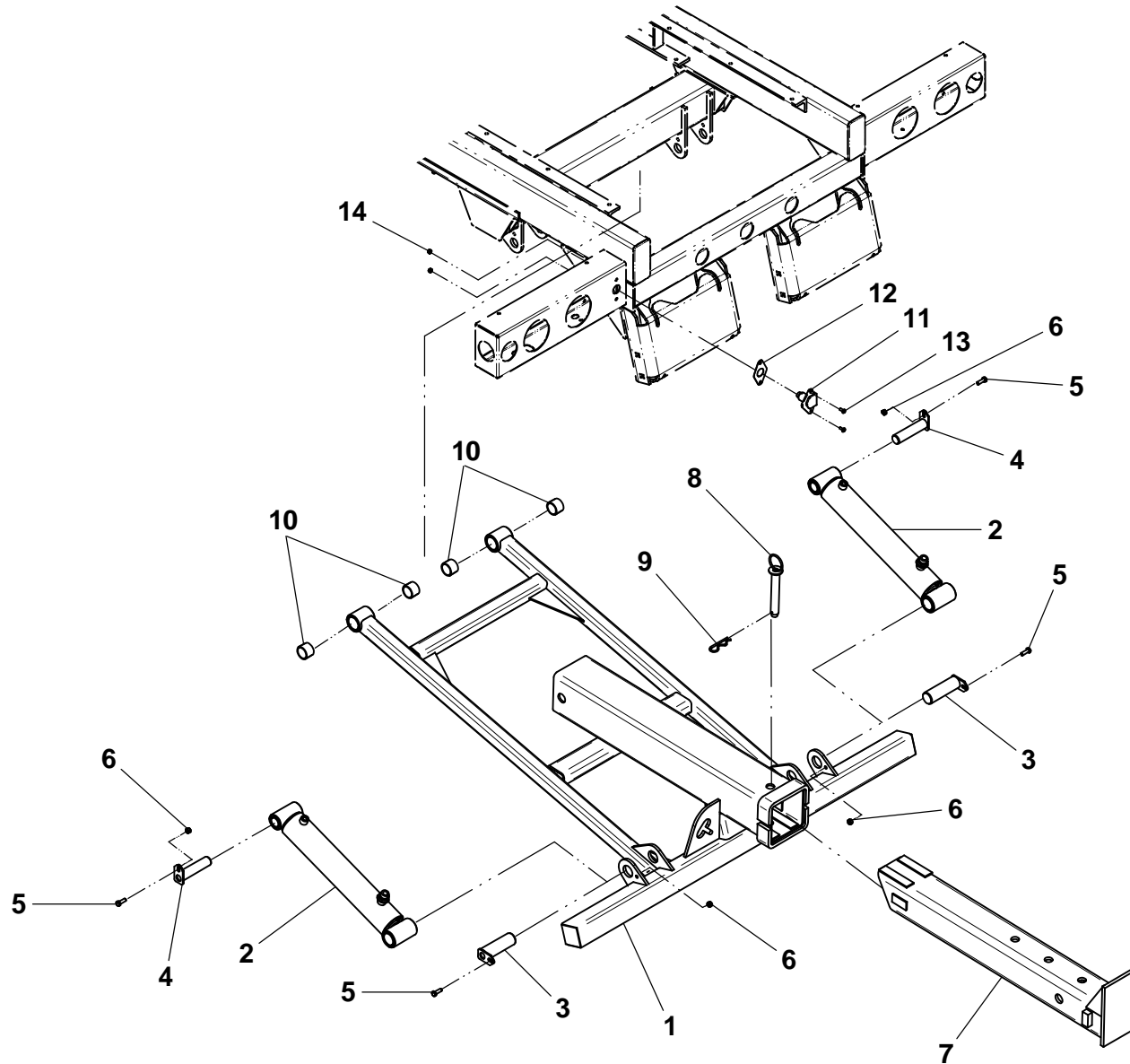

HYDRAULIC REAR DOCK STABILIZER WITH HYDRAULIC EXTEND PINTLE MOUNTING PLATE

ITEM	PART NO.	DESCRIPTION	QTY
1	3849000028	Stabilizer Weld w/ Manual Pintle Plate	1
2	3320000123	Cylinder Assembly	2
3	3691000165	Pin Weld	2
4	3691000073	Pin Weld	2
5	7115160950	Capscrew, 0.38"-16NC x 1.12"	4
6	7660162601	Locknut, 0.38"-16NC	4
7	3170000203	Inner Boom Weld	1
8	3691000064	Pin Weld	1
9	7691000001	Hair Pin	1
10	3320000117	Cylinder Assembly	1
11	4691000430	Pin	1
12	4691000429	Pin	1
13	7754000006	Retaining Ring	1
14	7082000017*	Bearing	4
15	7291000003	4-Way Receptacle	1
16	7796000048	Gasket	1
17	7114140528	Screw, 0.25"-20NC x 0.63"	2
18	7660142601	Locknut, 0.25"-20NC	2

* included in Stabilizer Weld, P/N 3849000028

HYDRAULIC REAR DOCK STABILIZER WITH HYDRAULIC EXTEND PINTLE MOUNTING PLATE

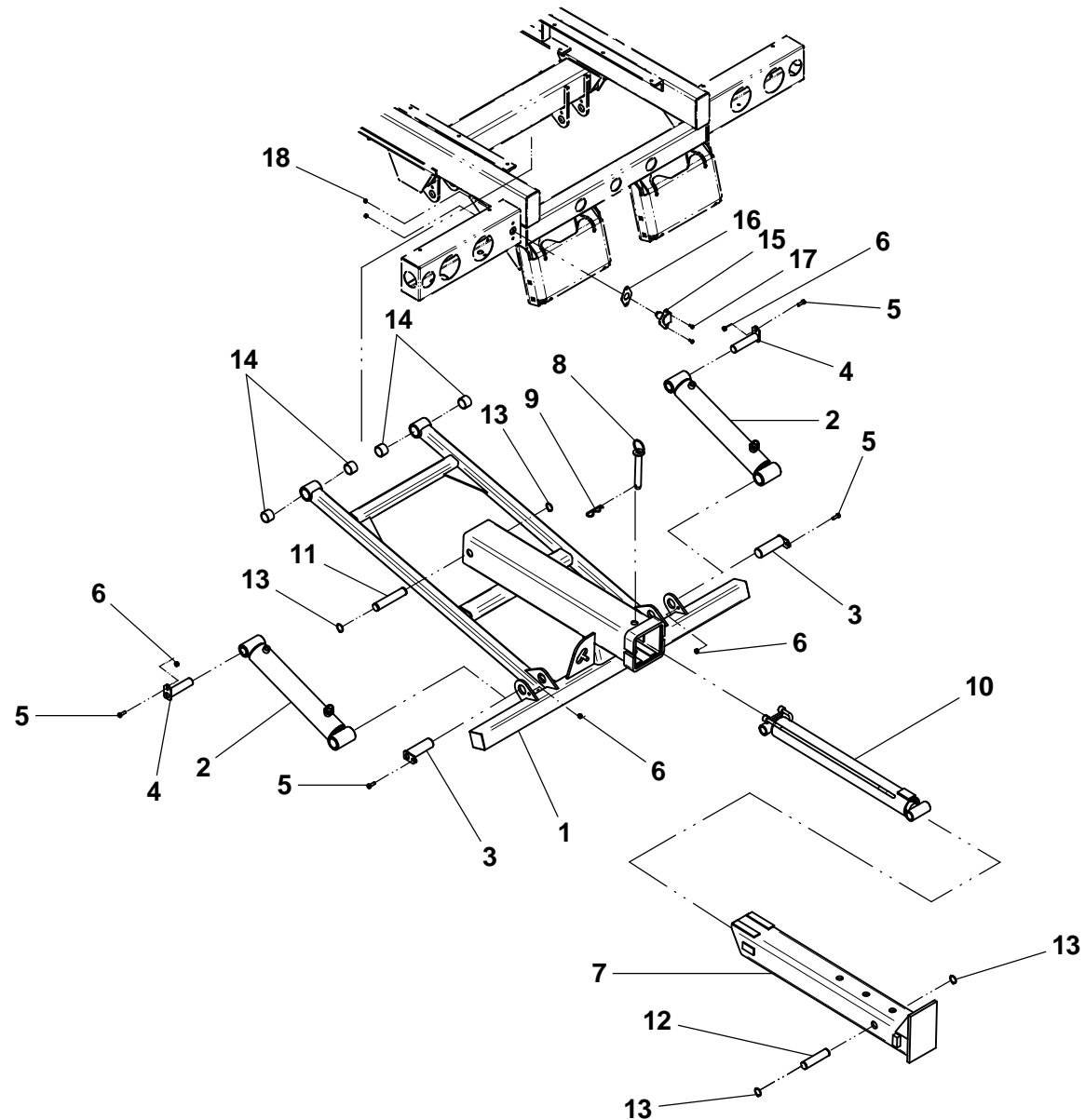

HYDRAULIC REAR DOCK STABILIZER WITH HYDRAULIC EXTEND WHEEL LIFT

ITEM	PART NO.	DESCRIPTION	QTY
1	3849000030	Stabilizer Weld	1
2	3170000304	Inner Boom Weld	1
3	3320000115	Cylinder Assembly	1
4	4691000296	Pin	1
5	4691000268	Pin	1
6	7754000006	Retaining Ring	4
7	7082000021*	Bushing	1
8	4679000046	Wear Pad	1
9	4017000739	Angle	2
10	7118140418	Capscrew, 0.25"-20NC x 0.50"	4
11	7950100151	Washer, 0.19" ID	4
12	4679000211	Wear Pad	1
13	3073000010	Stabilizer Base Weld	2
14	7691000071	Hitch Pin	2
15	7082000017+	Bearing	4
16	3320000132	Cylinder assembly	2
17	3691000184	Pin Weld	4
18	7115160950	Capscrew, 0.38"-16NC x 1.12"	2
19	7660162601	Locknut, 0.38"-16NC	2
20	7291000003	4-Way Receptacle	1
21	7796000048	Gasket	1
22	7114140528	Screw, 0.25"-20NC x 0.63"	1
23	7660142601	Locknut, 0.25"-20NC	1

* included in Inner Boom Weld, P/N 3170000304

+ included in Stabilizer Weld, P/N 3849000030

HYDRAULIC REAR DOCK STABILIZER WITH HYDRAULIC EXTEND WHEEL LIFT

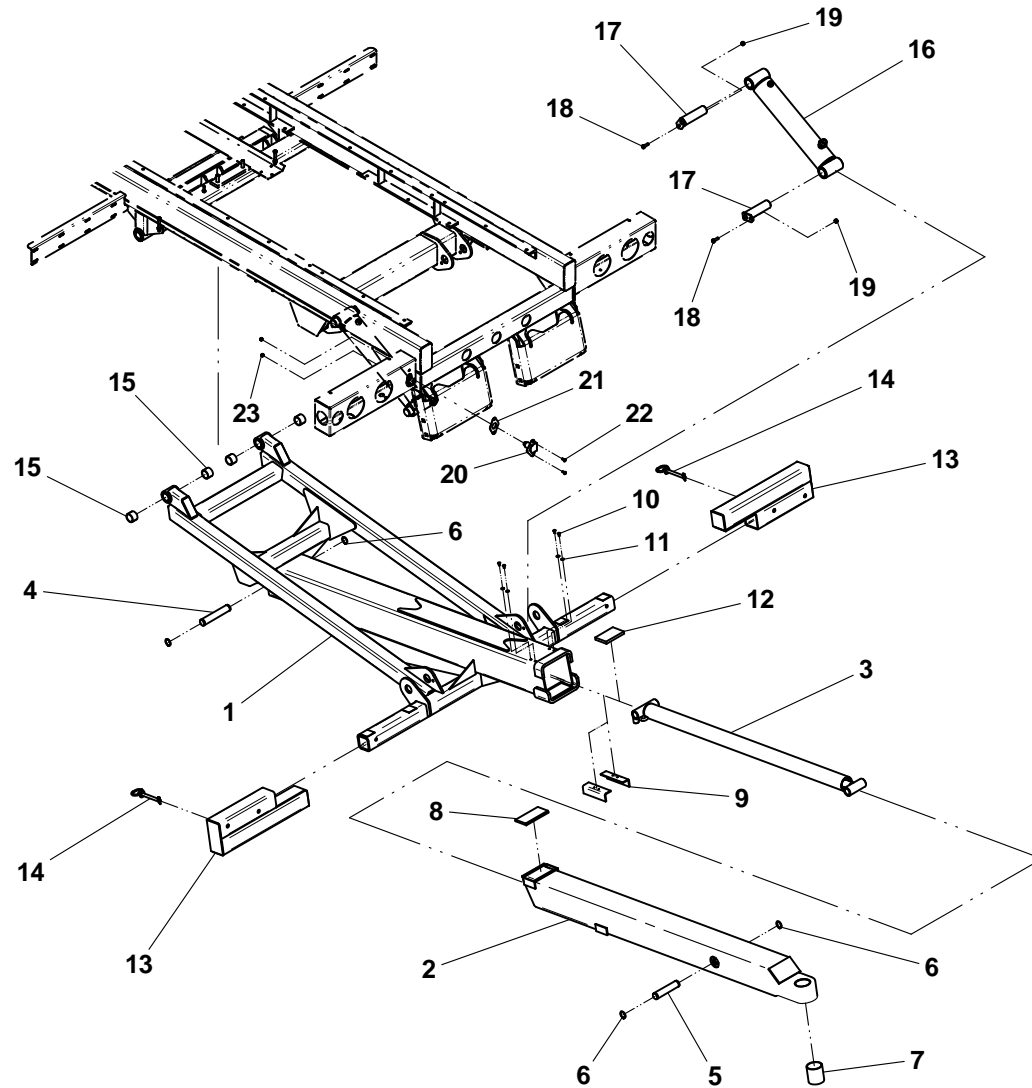

BALL HITCH MOUNTING PLATE - IRL

ITEM	PART NO.	DESCRIPTION	QTY
1	3170000313	Outer Boom Weld	1
2	3911000062	Inner Boom Weld	1
3	3320000116	Cylinder Assembly	1
4	4691000430	Pin	1
5	4691000429	Pin	1
6	7754000006	Retaining Ring	4
7	3691000064	Pin Weld	1
8	7691000001	Hair Pin	1
9	3320000124	Cylinder Assembly	2
10	3691000164	Pin Weld	2
11	7115160950	Capscrew, 0.38"-16NC x 1.12"	5
12	7660162601	Locknut, 0.38"-16NC	5
13	3691000073	Pin Weld	3
14	3020000102	Arm Weld	2
15	7082000017*	Bushing	4
16	7082000018*	Bushing	4
17	7082000016+	Bushing	2
18	7291000003	4-Way Receptacle	1
19	7796000048	Gasket	1
20	7114140528	Screw, 0.25"-20NC x 0.63"	2
21	7660142601	Locknut, 0.25"-20NC	2
22	4330000002	Reflective Tape	2

* included in Arm Weld, P/N 3020000102

+ included in Outer Boom Weld, P/N 3170000313

BALL HITCH MOUNTING PLATE - IRL

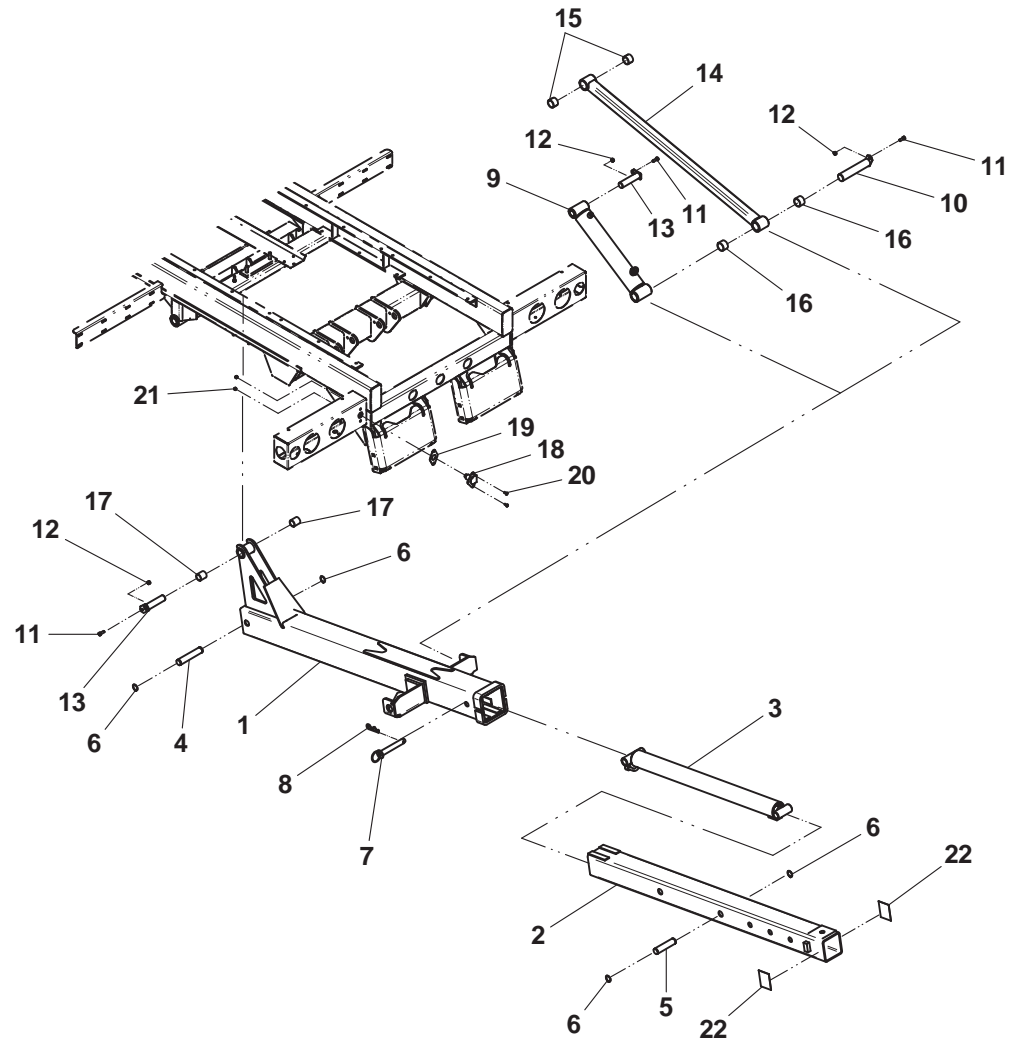

BALL HITCH MOUNTING PLATE - HYDRAULIC EXTEND

ITEM	PART NO.	DESCRIPTION	QTY
1	3170000314	Outer Boom Weld	1
2	3911000062	Inner Boom Weld	1
3	3320000116	Cylinder Assembly	1
4	4691000430	Pin	1
5	4691000429	Pin	1
6	7754000006	Retaining Ring	4
7	3691000073	Pin Weld	1
8	3691000064	Pin Weld	1
9	7115160950	Capscrew, 0.38"-16NC x 1.12"	1
10	7660162601	Locknut, 0.38"-16NC	1
11	3691000097	Pin Weld	1
12	7691000001	Hair Pin	2
13	7082000016*	Bushing	2
14	7291000003	4-Way Receptacle	1
15	7796000048	Gasket	1
16	7114140528	Screw, 0.25"-20NC x 0.63"	2
17	7660142601	Locknut, 0.25"-20NC	2
18	4330000002	Reflective Tape	1

* included in Outer Boom Weld, P/N 3170000314

BALL HITCH MOUNTING PLATE - HYDRAULIC EXTEND

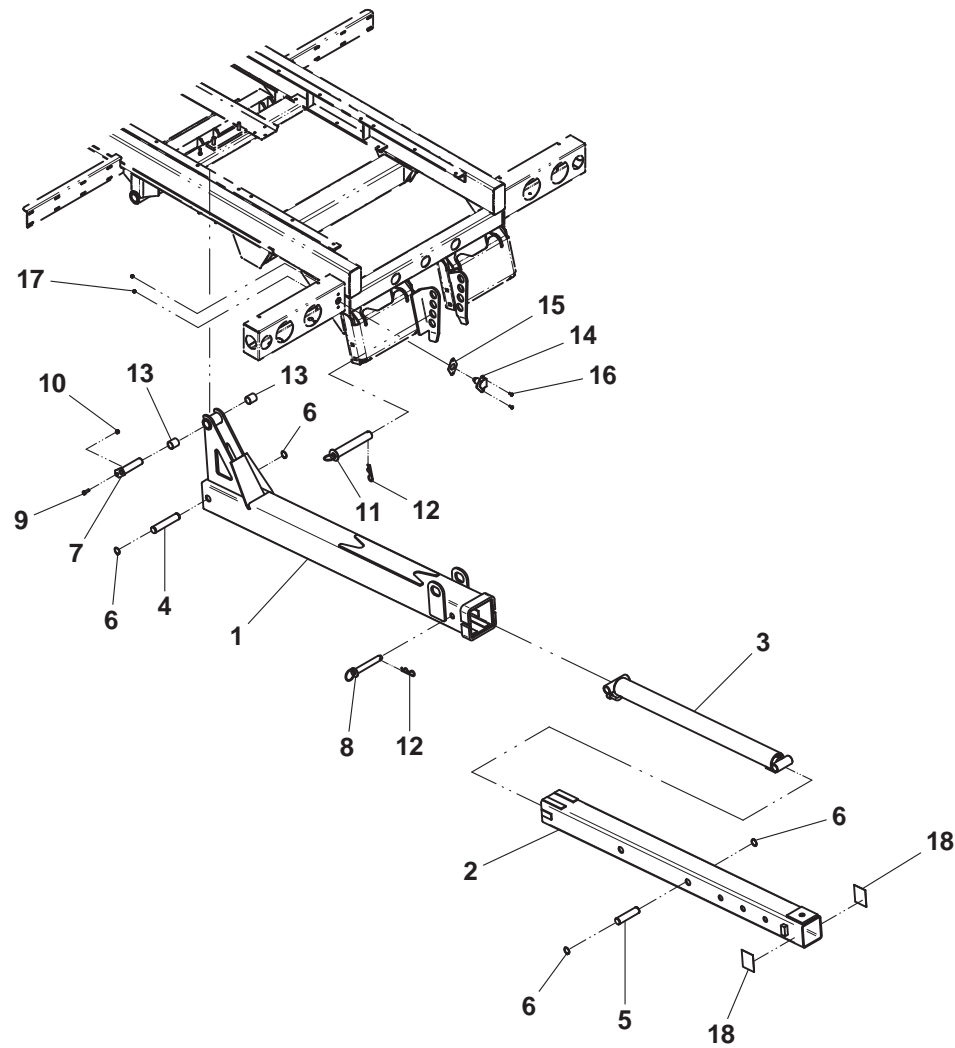

BALL HITCH MOUNTING PLATE - MANUAL EXTEND

ITEM	PART NO.	DESCRIPTION	QTY
1	3170000314	Outer Boom Weld	1
2	3911000062	Inner Boom Weld	1
3	3691000064	Pin Weld	1
4	7691000001	Hair Pin	2
5	3691000073	Pin Weld	1
6	7115160950	Capscrew, 0.38"-16NC x 1.12"	1
7	7660162601	Locknut, 0.38"-16NC	1
8	3691000097	Pin Weld	1
9	7082000016*	Bushing	2
10	7291000003	4-Way Receptacle	1
11	7796000048	Gasket	1
12	7114140528	Screw, 0.25"-20NC x 0.63"	2
13	7660142601	Locknut, 0.25"-20NC	2
14	4330000002	Reflective Tape	2

* included in Outer Boom Weld, P/N 3170000314

BALL HITCH MOUNTING PLATE - MANUAL EXTEND

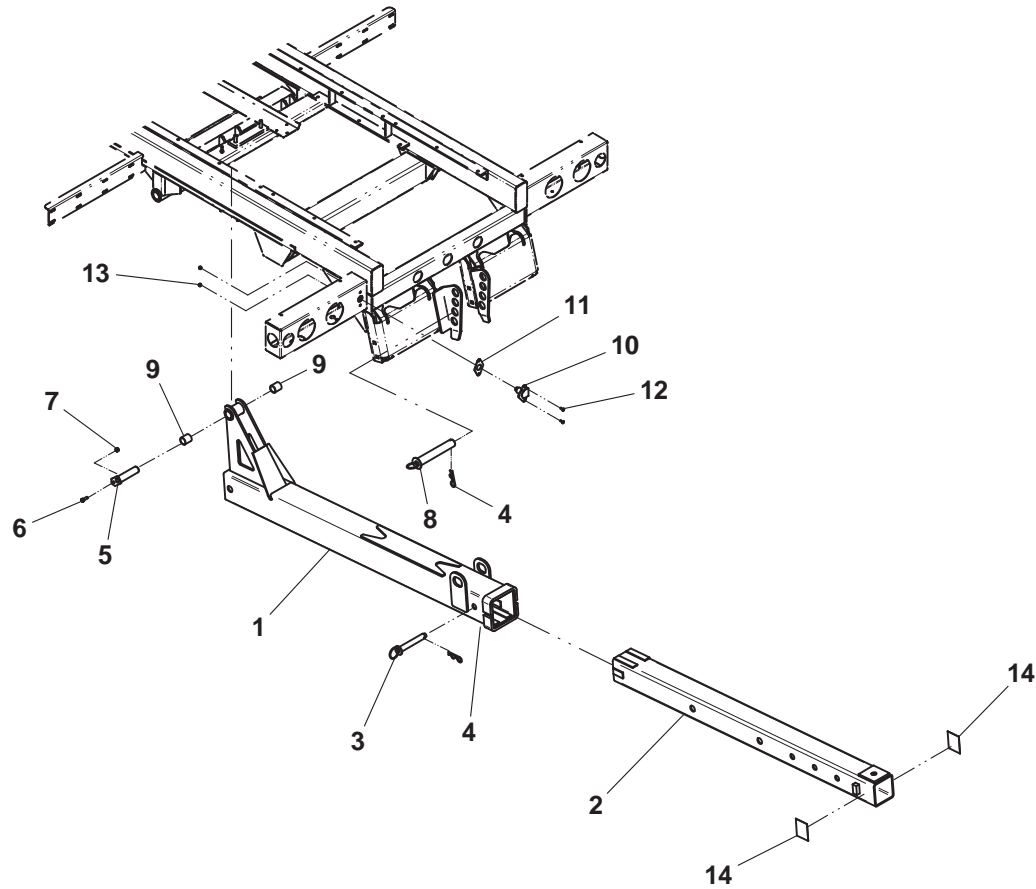

PINTLE HITCH MOUNTING PLATE - IRL

ITEM	PART NO.	DESCRIPTION	QTY
1	3170000313	Outer Boom Weld	1
2	3170000208	Inner Boom Weld	1
3	3320000116	Cylinder Assembly	1
4	4691000430	Pin	1
5	4691000429	Pin	1
6	7754000006	Retaining Ring	4
7	3691000064	Pin Weld	1
8	7691000001	Hair Pin	1
9	3320000124	Cylinder Assembly	1
10	3691000164	Pin Weld	2
11	7115160950	Capscrew, 0.38"-16NC x 1.12"	5
12	7660162601	Locknut, 0.38"-16NC	5
13	3691000073	Pin Weld	3
14	3020000102	Arm Weld	2
15	7082000017*	Bushing	4
16	7082000018*	Bushing	4
17	7082000016+	Bushing	2
18	7291000003	4-Way Receptacle	1
19	7796000048	Gasket	1
20	7114140528	Screw, 0.25"-20NC x 0.63"	2
21	7660142601	Locknut, 0.25"-20NC	2
22	4330000002	Reflective Tape	1
23	4330000645	Reflective Tape, LH	1
24	4330000646	Reflective Tape, RH	1

* included in Arm Weld, P/N 3020000102

+ included in Outer Boom Weld, P/N 3170000313

PINTLE HITCH MOUNTING PLATE - IRL

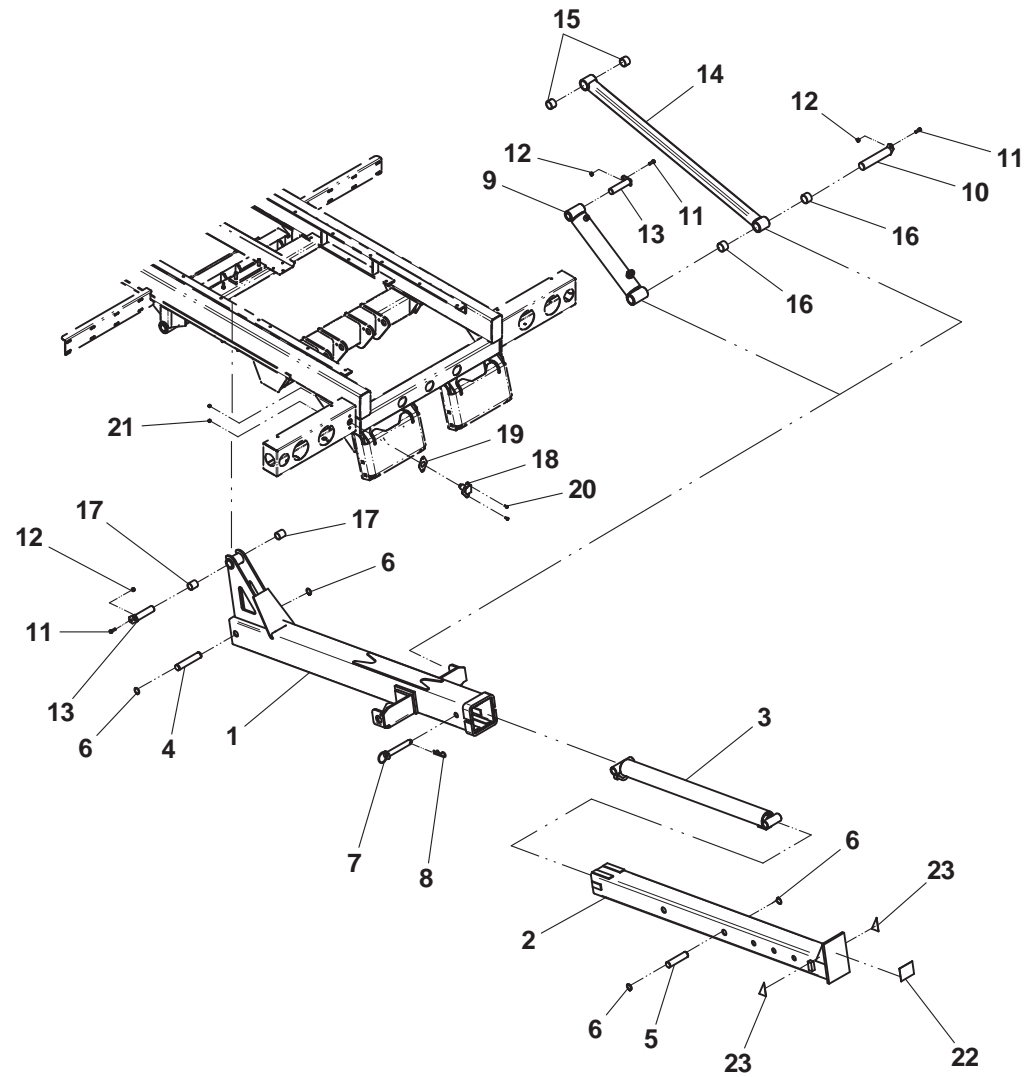

PINTLE HITCH MOUNTING PLATE - HYDRAULIC EXTEND

ITEM	PART NO.	DESCRIPTION	QTY
1	3170000314	Outer Boom Weld	1
2	3170000208	Inner Boom Weld	1
3	3320000116	Cylinder Assembly	1
4	4691000430	Pin	1
5	4691000429	Pin	1
6	7754000006	Retaining Ring	4
7	3691000073	Pin Weld	1
8	3691000064	Pin Weld	1
9	7115160950	Capscrew, 0.38"-16NC x 1.12"	1
10	7660162601	Locknut, 0.38"-16NC	1
11	3691000097	Pin Weld	1
12	7691000001	Hair Pin	2
13	7082000016*	Bushing	2
14	7291000003	4-Way Receptacle	1
15	7796000048	Gasket	1
16	7114140528	Screw, 0.25"-20NC x 0.63"	2
17	7660142601	Locknut, 0.25"-20NC	2
18	4330000002	Reflective Tape	1
19	4330000645	Reflective Tape, LH	1
20	4330000646	Reflective Tape, RH	1

* included in Outer Boom Weld, P/N 3170000314

PINTLE HITCH MOUNTING PLATE - HYDRAULIC EXTEND

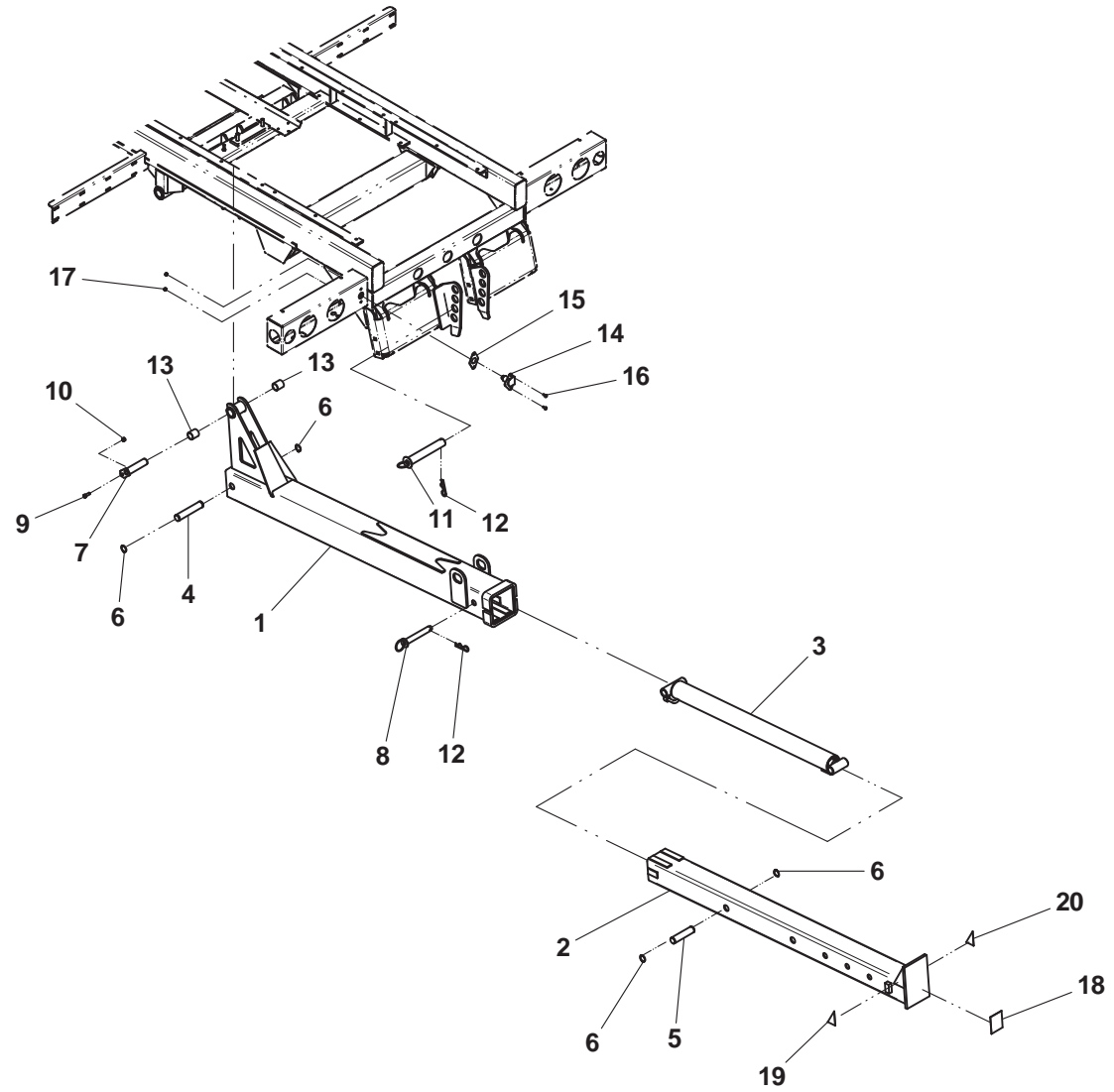

PINTLE HITCH MOUNTING PLATE - MANUAL EXTEND

ITEM	PART NO.	DESCRIPTION	QTY
1	3170000314	Outer Boom Weld	1
2	3170000208	Inner Boom Weld	1
3	3691000064	Pin Weld	1
4	7691000001	Hair Pin	2
5	3691000073	Pin Weld	1
6	7115160950	Capscrew, 0.38"-16NC x 1.12"	1
7	7660162601	Locknut, 0.38"-16NC	1
8	3691000097	Pin Weld	1
9	7082000016*	Bushing	2
10	7291000003	4-Way Receptacle	1
11	7796000048	Gasket	1
12	7114140528	Screw, 0.25"-20NC x 0.63"	2
13	7660142601	Locknut, 0.25"-20NC	2
14	4330000002	Reflective Tape	1
15	4330000645	Reflective Tape, LH	1
16	4330000646	Reflective Tape, RH	1

* included in Outer Boom Weld, P/N 3170000314

PINTLE HITCH MOUNTING PLATE - MANUAL EXTEND

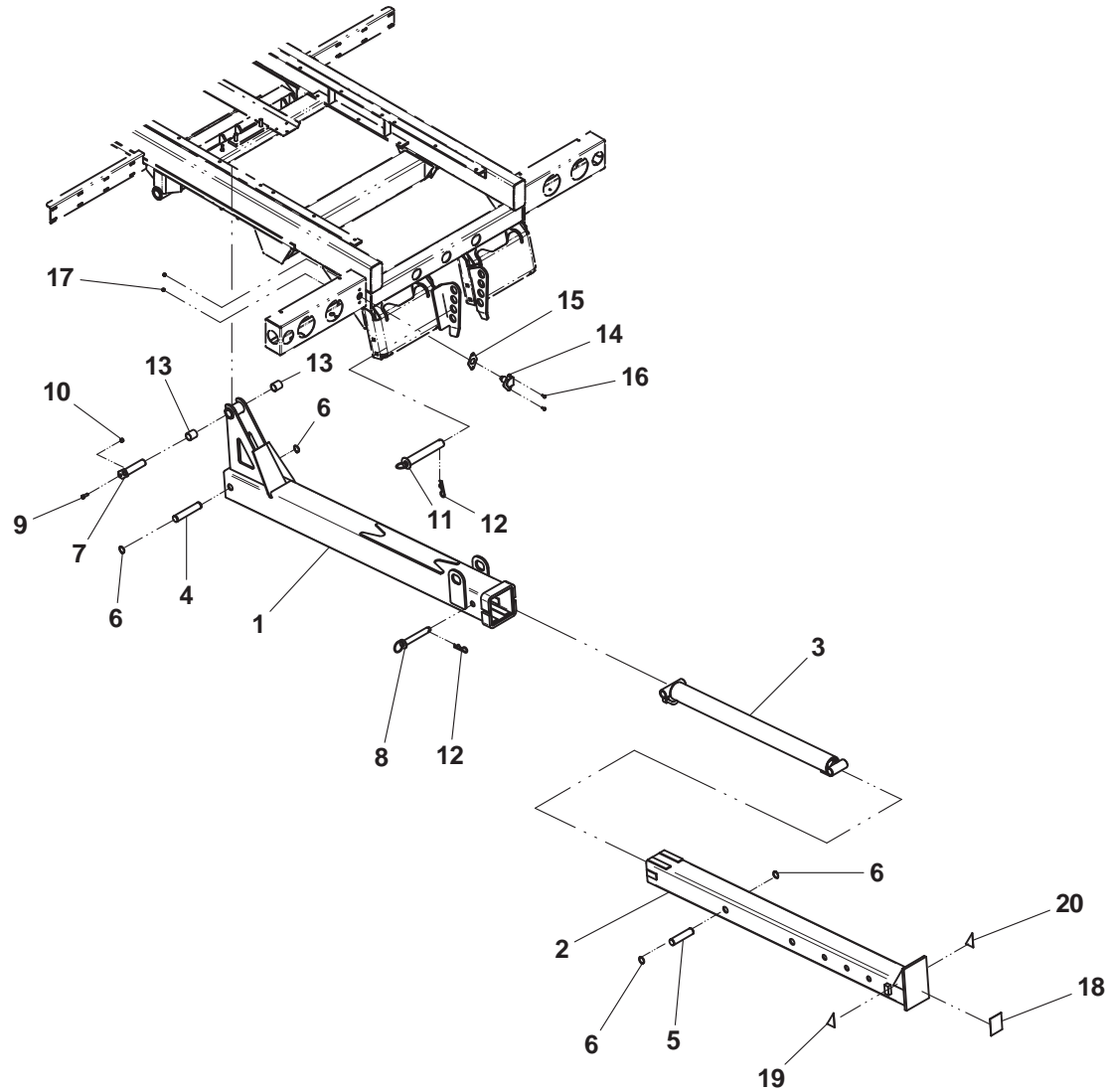

TOWBAR - IRL

ITEM	PART NO.	DESCRIPTION	QTY
1	3170000313	Outer Boom Weld	1
2	3170000078	Inner Boom Weld	1
3	3320000116	Cylinder Assembly	1
4	4691000430	Pin	1
5	4691000429	Pin	1
6	7754000006	Retaining Ring	4
7	7440030000	Grease Fitting	1
8	3320000114	Cylinder Assembly	2
9	3691000164	Pin Weld	2
10	7115160950	Capscrew, 0.38"-16NC x 1.12"	5
11	7660162601	Locknut, 0.38"-16NC	5
12	3691000073	Pin Weld	3
13	3020000102	Arm Weld	2
14	7082000017*	Bushing	4
15	7082000018*	Bushing	4
16	7082000016+	Bushing	2
17	3556000026	Tow Hitch Weld (rubber tubes)	1
	3556000028	Tow Hitch Weld (keyslots)	
18	4120000008	Capscrew, 1.50"-12NF x 6.38"	1
19	7912000011	Tube Rubber	2
20	7291000003	4-Way Receptacle	1
21	7796000048	Gasket	1
22	7114140528	Screw, 0.25"-20NC x 0.63"	2
23	7660142601	Locknut, .025"-20NC	2
24	7330000419	Reflective Tape	2
25	4330000001	Reflective Tape	1

* included in Arm Weld, P/N 3020000102

+ included in Outer Boom Weld, P/N 3170000313

TOWBAR - IRL

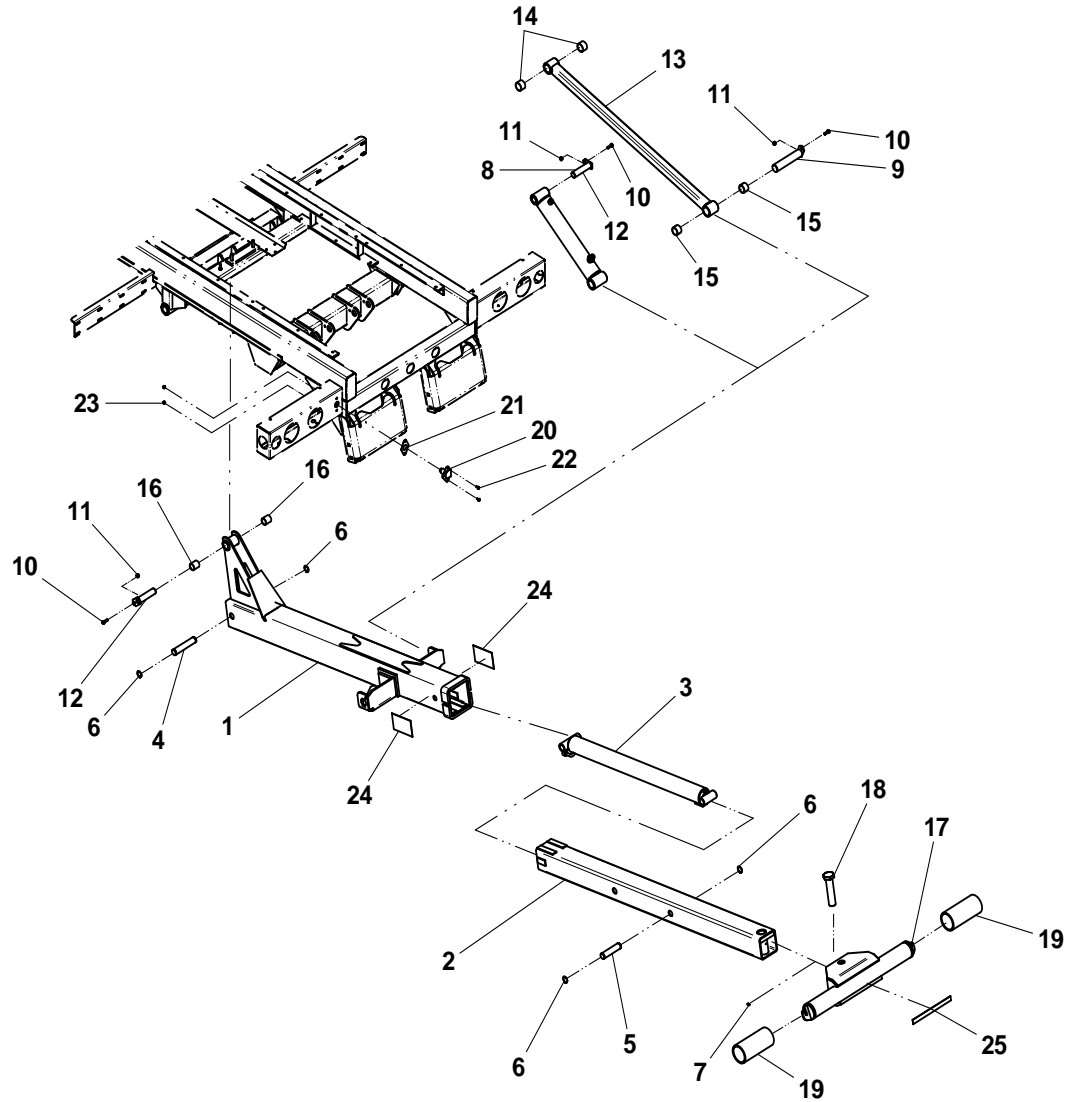

IRL towbar with rubber tubes shown

TOWBAR - HYDRAULIC EXTEND

ITEM	PART NO.	DESCRIPTION	QTY
1	3170000314	Outer Boom Weld	1
2	3170000048	Inner Boom Weld	1
3	3320000116	Cylinder Assembly	1
4	4691000430	Pin	1
5	4691000429	Pin	1
6	7754000006	Retaining Ring	4
7	7440030000	Grease Fitting	1
8	3691000073	Pin Weld	1
9	7115160950	Capscrew, 0.38"-16NC x 1.12"	1
10	7660162601	Locknut, 0.38"-16NC	1
11	3691000097	Pin Weld	1
12	7691000001	Hair Pin	1
13	7082000016*	Bushing	2
14	3556000023	Tow Hitch Weld	1
15	4120000008	Capscrew, 1.50"-12NF x 6.38"	1
16	7912000011	Tube Rubber	2
17	7291000003	4-Way Receptacle	1
18	7796000048	Gasket	1
19	7114140528	Screw, 0.25"-20NC x 0.63"	2
20	7660142601	Locknut, 0.25"-20NC	2
21	4330000002	Reflective Tape	2
22	4330000001	Reflective Tape	1

* included in Outer Boom Weld, P/N 3170000314

TOWBAR - HYDRAULIC EXTEND

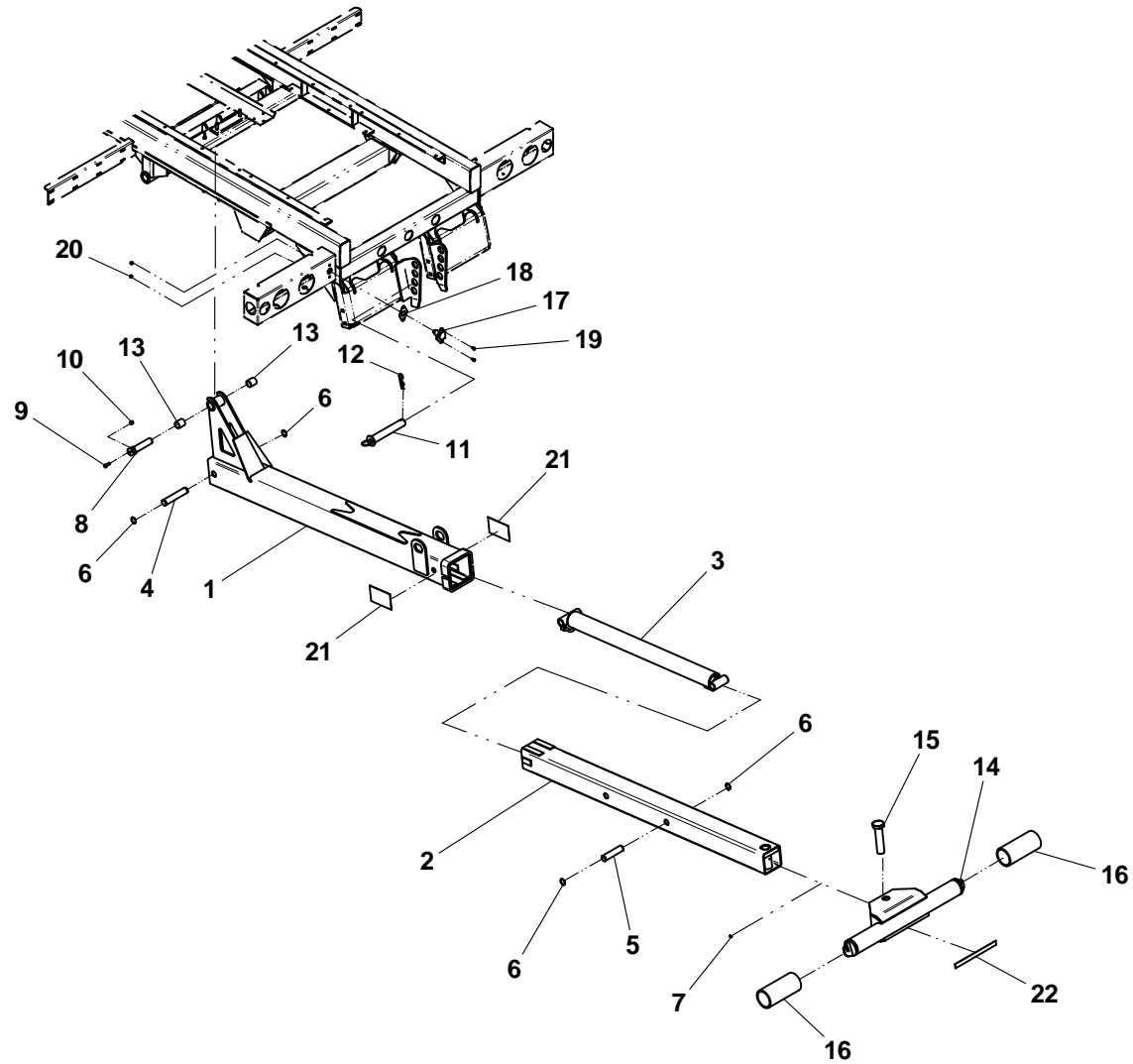

ROLL CYLINDER ASSEMBLY - P/N 3320000121

ITEM	PART NO.	DESCRIPTION	QTY
1	3071000116	Barrel Weld	1
2	4763000093	Rod	1
3	4698000009*	Piston	1
4	7796000013* #	Wear Ring	2
5	7796000064* #	Piston Locking "T" Seal	1
6	7755226609* #	Back-Up Ring	2
7	7755226000* #	"O" Ring	1
8	4553000010^	Head	1
9	7755338000^#	"O" Ring	1
10	7755338609^#	Back-Up Ring	1
11	7754000012^#	Wear Ring	1
12	7796000025^#	Rod Seal	1
13	7796000008^#	Rod Wiper Seal	1
14	7754000016 #	Retaining Ring	1
15	7754000027 #	Retaining Ring	1
16	7661000035	Locknut	2

* included in Piston Assembly, P/N 3698000004

^ included in Head Assembly, P/N 3553000014

available only in Service Kit #7577250025

ROLL CYLINDER ASSEMBLY - P/N 3320000121

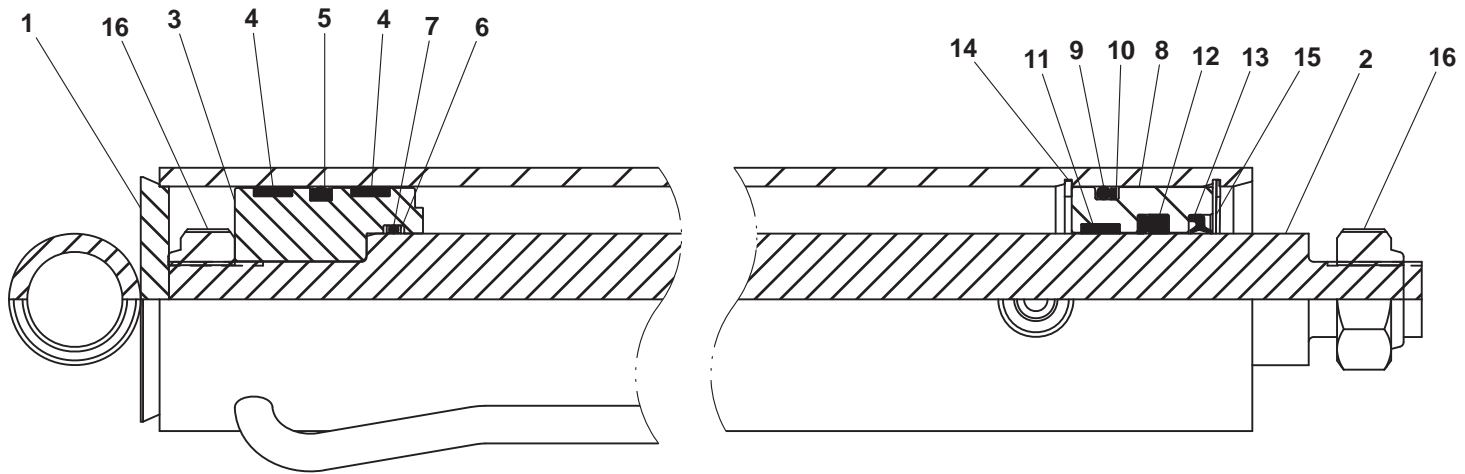

TILT CYLINDER ASSEMBLY - P/N 3320000122

ITEM	PART NO.	DESCRIPTION	QTY
1	3071000117	Barrel Weld	1
2	3763000127	Rod Weld	1
3	4698000007*	Piston	1
4	7754000003* #	Wear Ring	2
5	7796000063* #	Piston Locking "T" Seal	1
6	7755224609* #	Back-Up Ring	2
7	7755224000* #	"O" Ring	1
8	4553000008^	Head	1
9	7755330008^ #	"O" Ring	1
10	7755334609^ #	Back-Up Ring	1
11	7754000004^ #	Wear Ring	1
12	7796000045^ #	Rod Seal	1
13	7796000024^ #	Rod Wiper Seal	1
14	7754000002#	Retaining Ring	1
15	7754000026#	Retaining Ring	1
16	7661000034	Locknut	1
17	7082000016	Bearing	4

* included in Piston Assembly, P/N 3698000001

^ included Head Assembly, P/N 3553000011

available only in Service Kit #7577250042

TILT CYLINDER ASSEMBLY - P/N 3320000122

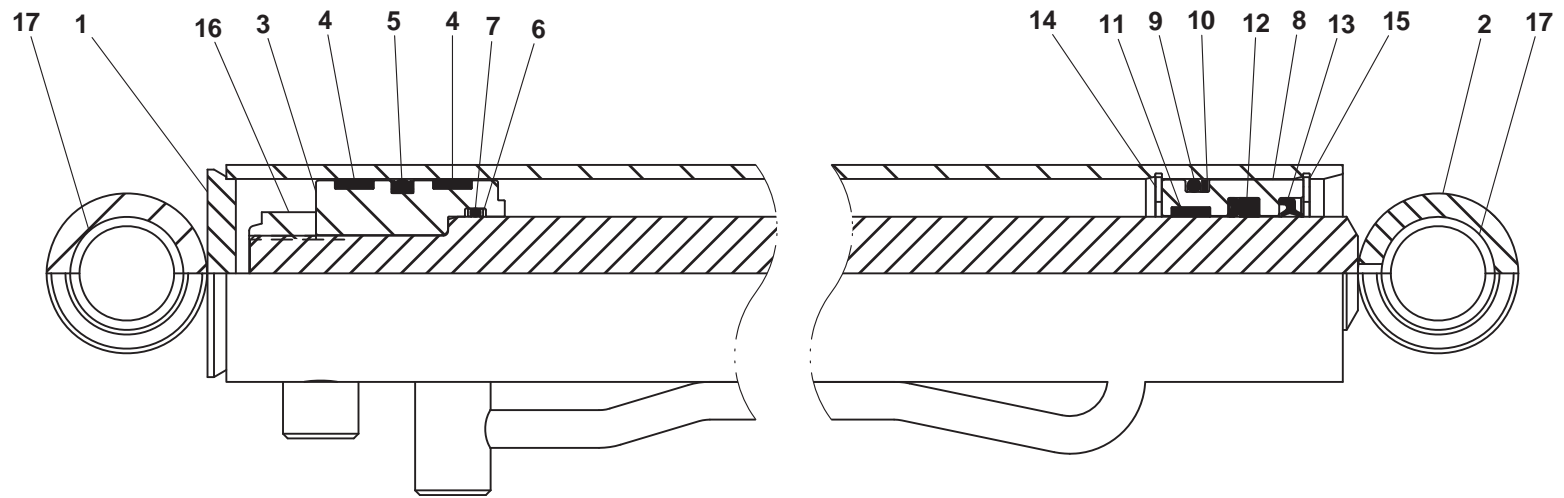

WHEEL LIFT EXTEND CYLINDER ASSEMBLY - P/N 3320000115

ITEM	PART NO.	DESCRIPTION	QTY
1	3071000106	Barrel Weld	1
2	3763000119	Rod Weld	1
3	4698000015*	Piston	1
4	7754000053* #	Wear Ring	2
5	7796000067* #	Piston Locking "T" Seal	1
6	7755222609* #	Back-Up Ring	2
7	7755222000* #	"O" Ring	1
8	4553000016^	Head	1
9	7755330000^ #	"O" Ring	1
10	7755330609^ #	Back-Up Ring	1
11	7754000054^ #	Wear Ring	1
12	7796000045^ #	Rod Seal	1
13	7796000046^ #	Rod Wiper Seal	1
14	7754000051#	Retaining Ring	2
15	7661000034	Locknut	1

* included in Piston Assembly, P/N 3698000006

^ included in Head Assembly, P/N 3553000016

available only in Service Kit #7577250206

WHEEL LIFT EXTEND CYLINDER ASSEMBLY - P/N 3320000115

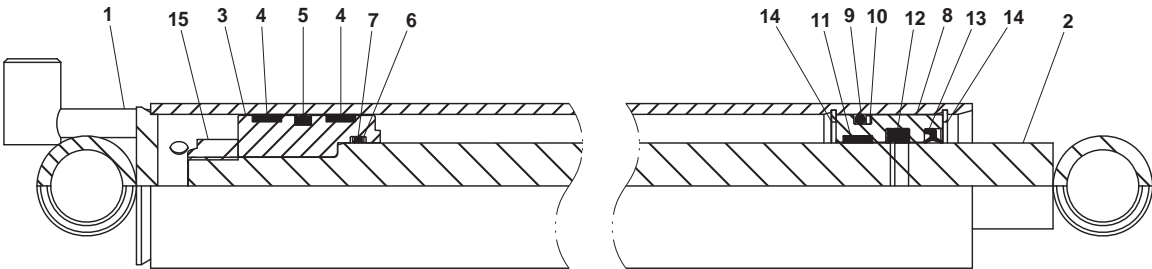

IRL CYLINDER ASSEMBLY - P/N 3320000114, P/N 3320000123 & P/N 3320000124

ITEM	PART NO.	DESCRIPTION	QTY
1	3071000105	Barrel Weld (P/N 3320000114)	1
	3071000118	Barrel Weld (P/N 3320000123)	
	3071000119	Barrel Weld (P/N 3320000124)	
2	3763000118	Rod Weld (P/N 3320000114)	1
	3763000128	Rod Weld (P/N 3320000123)	
	3763000129	Rod Weld (P/N 3320000124)	
3	4698000007*	Piston	1
4	7754000003* #	Wear Ring	2
5	7796000063* #	Piston Locking "T" Seal	1
6	7755224609* #	Back-Up Ring	2
7	7755224000* #	"O" Ring	1
8	4553000008^	Head	1
9	7755334000^ #	"O" Ring	1
10	7755334609^ #	Back-Up Ring	1
11	7754000004^ #	Wear Ring	1
12	7796000024^ #	Rod Seal	1
13	7796000008^ #	Rod Wiper Seal	1
14	7754000002 #	Retaining Ring	1
15	7754000026 #	Retaining Ring	1
16	7661000034	Locknut	1
17	7082000016	Bearing	2
18	7082000018	Bearing	2

* included in Piston Assembly, P/N 3698000001

^ included in Head Assembly, P/N 3553000011

available only in Service Kit #7577250024

IRL CYLINDER ASSEMBLY - P/N 3320000114, P/N 3320000123 & P/N 3320000124

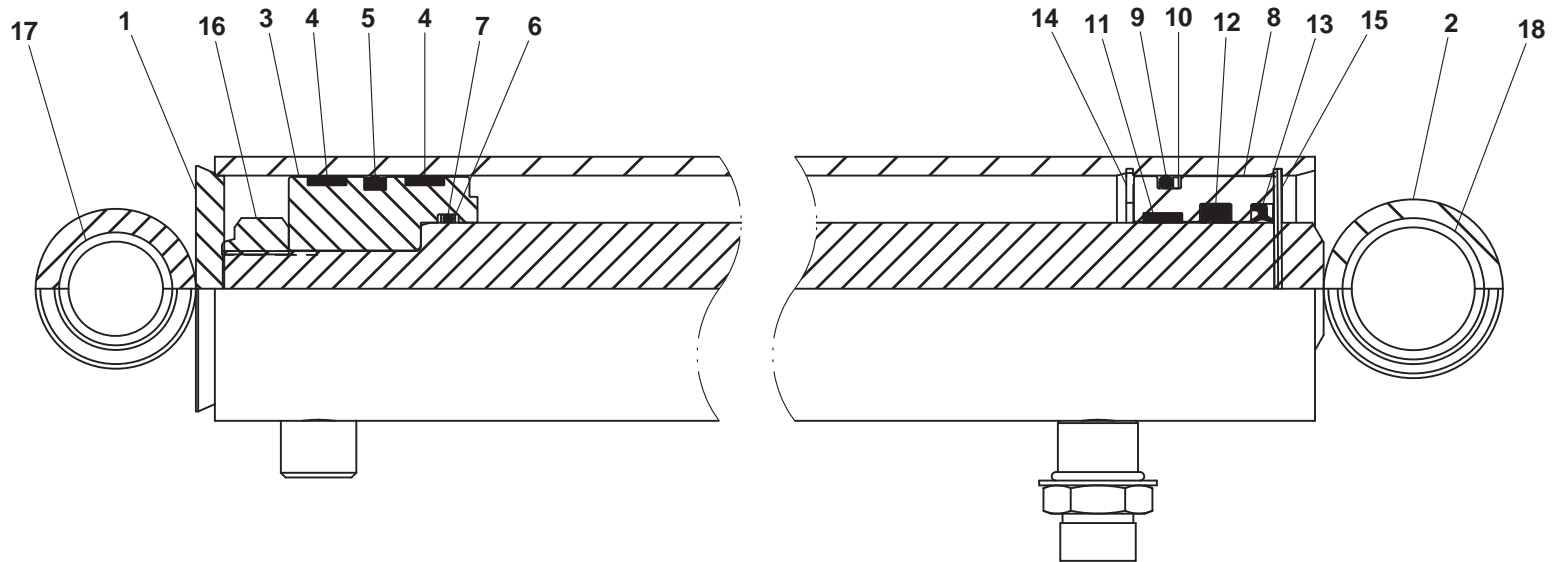

ZOD CYLINDER ASSEMBLY - P/N 3320000125

ITEM	PART NO.	DESCRIPTION	QTY
1	3071000120	Barrel Weld	1
2	3763000130	Rod Weld	1
3	4698000015*	Piston	1
4	7754000053* #	Wear Ring	2
5	7796000067* #	Piston Locking "T" Seal	1
6	7755222609* #	Back-Up Ring	2
7	7755222000* #	"O" Ring	1
8	4553000016^	Head	1
9	7755330000^#	"O" Ring	1
10	7755330609^#	Back-Up Ring	1
11	7754000054^#	Wear Ring	1
12	7796000045^#	Rod Seal	1
13	7796000046^#	Rod Wiper Seal	1
14	7754000051 #	Retaining Ring	2
15	7661000034	Locknut	1
16	7082000016	Bearing	4

* include in Piston Assembly, P/N 3698000006

^ included in Head Assembly, P/N 3553000016

available only in Service Kit #7577250206

ZOD WHEEL LIFT CYLINDER ASSEMBLY - P/N 3320000125

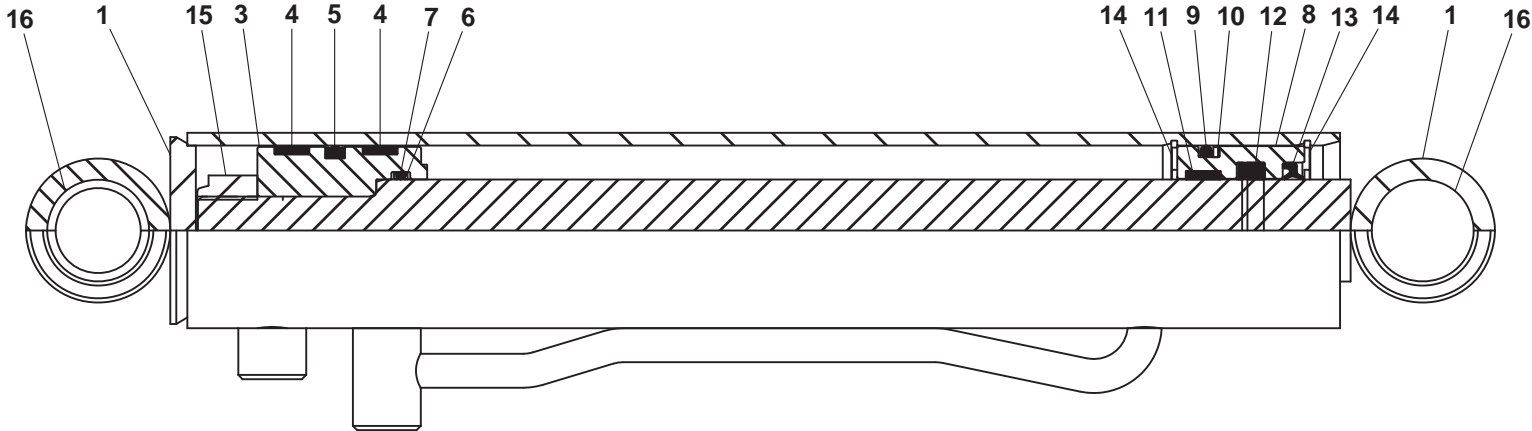

STABILIZER CYLINDER ASSEMBLY - P/N 3320000126

ITEM	PART NO.	DESCRIPTION	QTY
1	3071000121	Barrel Weld	1
2	3763000128	Rod Weld	1
3	4698000007*	Piston	1
4	7754000003* #	Wear Ring	2
5	7796000063* #	Piston Locking "T" Seal	1
6	7755224609* #	Back-Up Ring	2
7	7755224000* #	"O" Ring	1
8	4553000008^	Head	1
9	7755334000^ #	"O" Ring	1
10	7755334609^ #	Back-Up Ring	1
11	7754000004^ #	Wear Ring	1
12	7796000024^ #	Rod Seal	1
13	7796000008^ #	Rod Wiper Seal	1
14	7754000002 #	Retaining Ring	1
15	7754000026 #	Retaining Ring	1
16	7661000034	Locknut	1
17	7082000016	Bearing	2
18	7082000018	Bearing	2

* included in Piston Assembly, P/N 3698000001

^ included in Head Assembly, P/N 3553000011

available only in Service Kit #7577250024

STABILIZER CYLINDER ASSEMBLY - P/N 3320000126

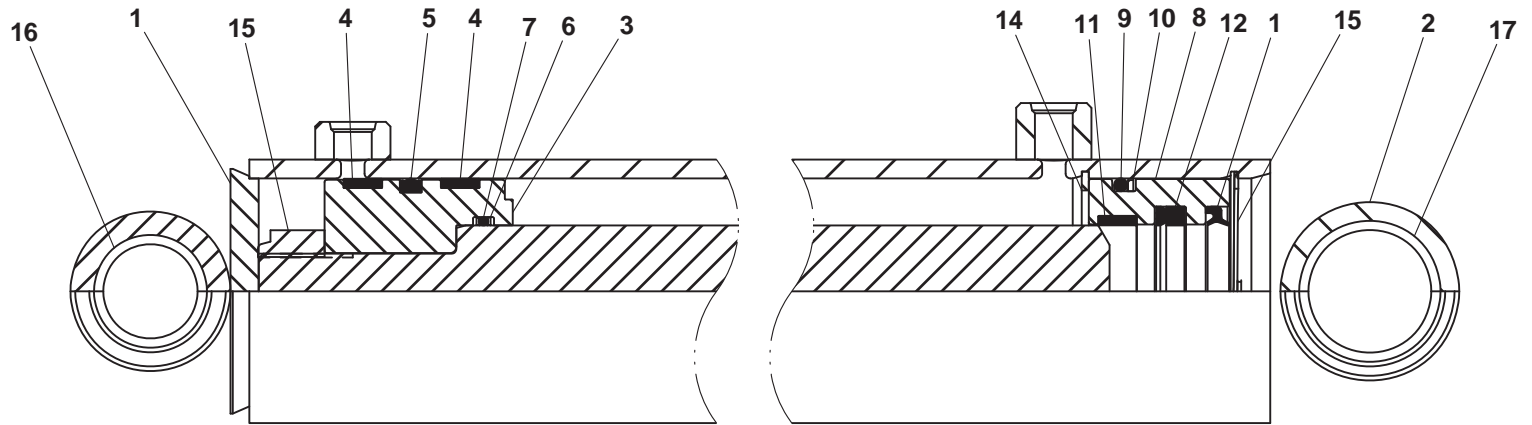

TOW OPTION HYDRAULIC EXTEND CYLINDER ASSEMBLY - P/N 3320000116 & P/N 3320000117

ITEM	PART NO.	DESCRIPTION	QTY
1	3071000107	Barrel Weld (IRL tow option extend)	1
	3071000108	Barrel Weld (stabilizer tow opt extend)	
2	3763000120	Rod Weld (IRL tow option extend)	1
	3763000121	Rod Weld (stabilizer tow opt extend)	
3	4698000007*	Piston	1
4	7754000003* #	Wear Ring	2
5	7796000063* #	Piston Locking "T" Seal	1
6	7755224609* #	Back-Up Ring	2
7	7755224000* #	"O" Ring	1
8	4553000008^	Head	1
9	7755334000^ #	"O" Ring	1
10	7755334609^ #	Back-Up Ring	1
11	7754000004^ #	Wear Ring	1
12	7796000024^ #	Rod Seal	1
13	7796000008^ #	Rod Wiper Seal	1
14	7754000002 #	Retaining Ring	1
15	7754000026 #	Retaining Ring	1
16	7661000034	Locknut	1

* included in Piston Assembly, P/N 3698000001

^ included in Head Assembly, P/N 3553000011

available only in Service Kit #7577250024

TOW OPTION HYDRAULIC EXTEND CYLINDER ASSEMBLY - P/N 3320000116 & P/N 3320000117

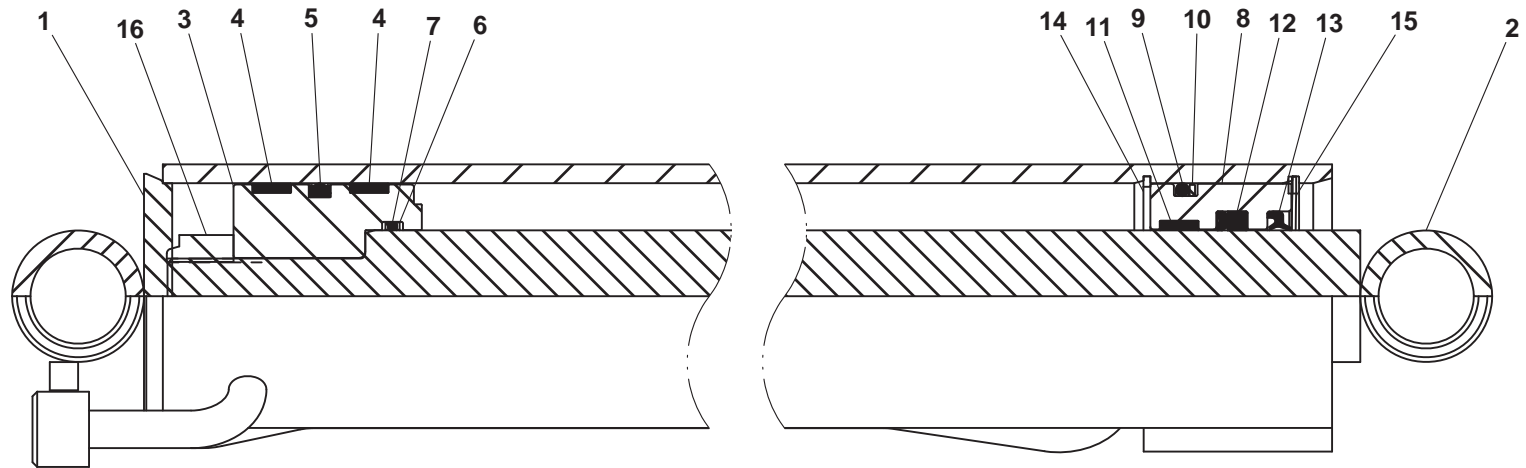

STABILIZER CYLINDER ASSEMBLY - P/N 3320000132

ITEM	PART NO.	DESCRIPTION	QTY
1	3071000124	Barrel Weld	1
2	3763000133	Rod Weld	1
3	4698000009*	Piston	1
4	7796000013* #	Wear Ring	2
5	7796000064* #	Piston Locking "T" Seal	1
6	7755226609* #	Back-Up Ring	2
7	7755226000* #	"O" Ring	1
8	4553000010^	Head	1
9	7755338000^ #	"O" Ring	1
10	7755338609^ #	Back-Up Ring	1
11	7754000012^ #	Wear Ring	1
12	7796000025^ #	Rod Seal	1
13	7796000011^ #	Rod Wiper Seal	1
14	7754000016 #	Retaining Ring	1
15	7754000027 #	Retaining Ring	1
16	7661000035	Locknut	1
17	7082222218	Bearing	4

* included in Piston Assembly, P/N 3698000004

^ included in Head Assembly, P/N 3553000014

available only in Service Kit #7577250024

STABILIZER CYLINDER ASSEMBLY - P/N 3320000132

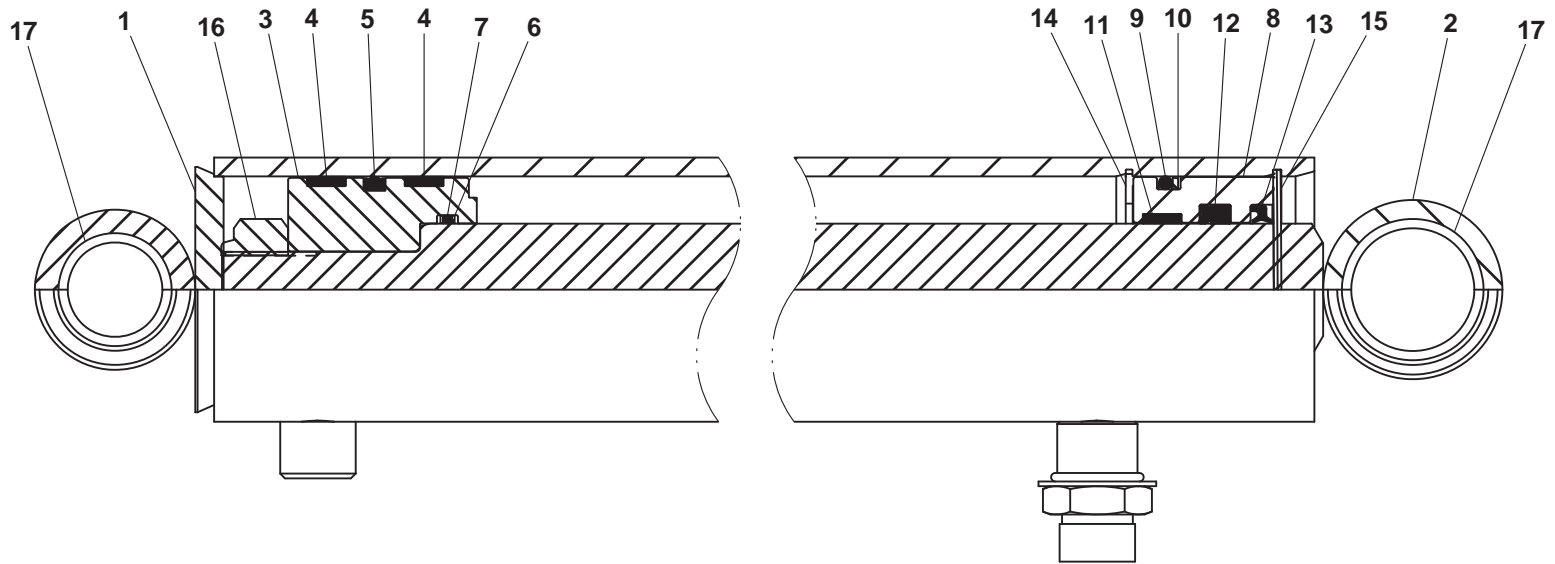

LIGHTBARS

ITEM	PART NO.	DESCRIPTION	QTY
1	7590000306	Lightbar, Amber Halogen	1
	7590000311	Lightbar, Amber LED	
2	4178000402	Bracket (standard mount)	2
	4178000437	Bracket (high mount)	
3	7115180850	Capscrew, 0.50"-13NC x 1.00"	2
4	7950180252	Flatwasher, 0.50" ID	2
5	7950180000	Lockwasher, 0.50" ID	2

LIGHTBARS

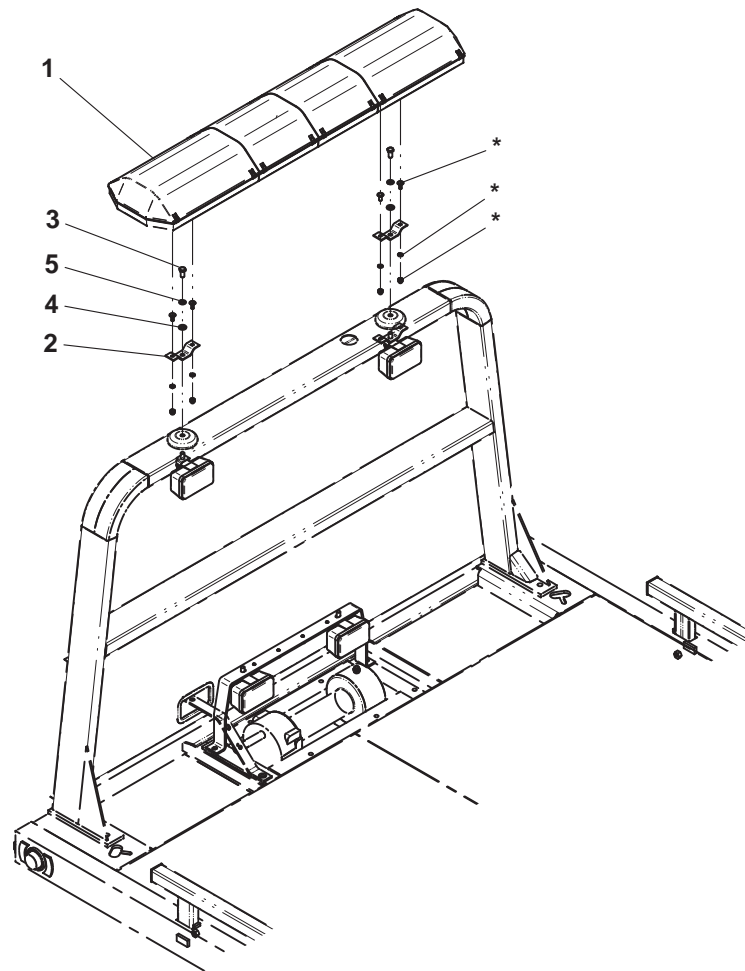

* included in Lightbar

SWITCH PANELS

ITEM	PART NO.	DESCRIPTION	QTY
1	4178000403	Bracket - 1 Function Switch Panel	1
2	4178000427	Bracket - 2 Function Switch Panel	1
3	7870000083	Switch	1
4	7870000113	Switch Panel - 3 Function, Mini In-Dash	1
5	7870000100	Switch Panel - 3 Function, In-Dash	1
6	7870000106	Switch Panel - 5 Function, In-Dash	1
7	7870000076	Switch Panel - 3 Function, In-Dash for IHC4300/4400	1
8	7870000053	Switch Panel - 3 Function, Under Dash	1
9	7870000063	Switch Panel - 5 Function, Under Dash	1
10	7870000089	Switch Panel - 5 Function	1

SWITCH PANELS

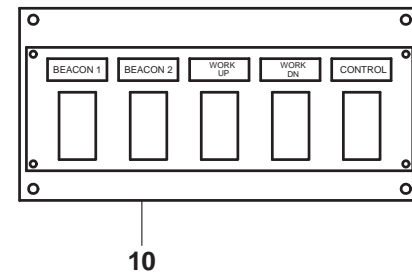
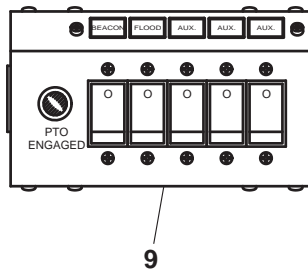
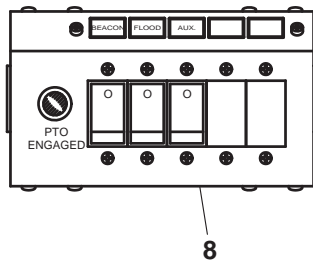
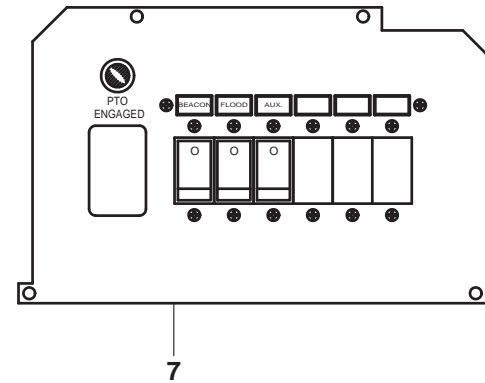
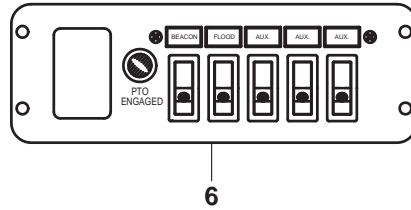
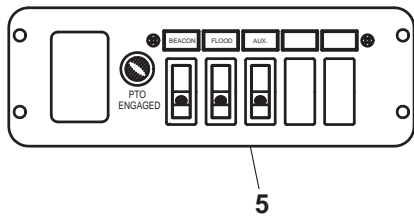
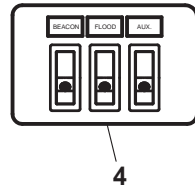
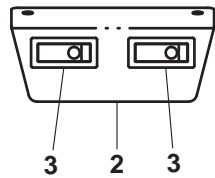
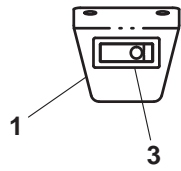

WORK LIGHTS

ITEM	PART NO.	DESCRIPTION	QTY
1	7590000223	Worklight	4
2	4178000402	Bracket	2
3	7790151253	Screw, 0.31"-18NC x 0.75	4
4	7493000003	Grommet	2
5	7552000222	Harness - Headboard Worklights	1
6	4178000423	Bracket	1
7	7280000011	Clip	6
8	7552000166	Harness - Winch Worklights	1
9	7590000185	Worklight	2

WORK LIGHTS

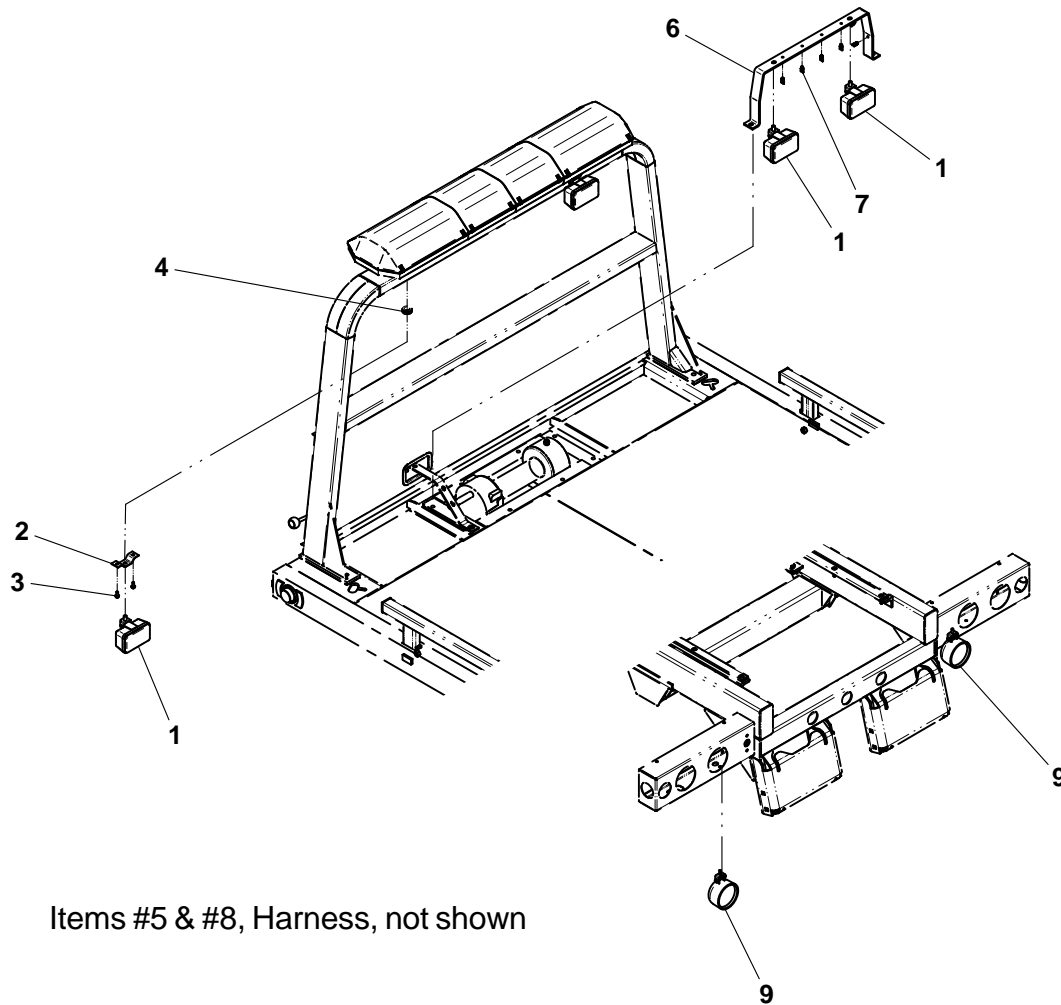

BOLT-ON D-RINGS

ITEM	PART NO.	DESCRIPTION	QTY
1	3556000019	D-Ring	1
2	7115182050	Capscrew, 0.50"-13NC x 2.50"	2
3	7660182601	Locknut, 0.50"-13NC	2

BOLT-ON D-RINGS

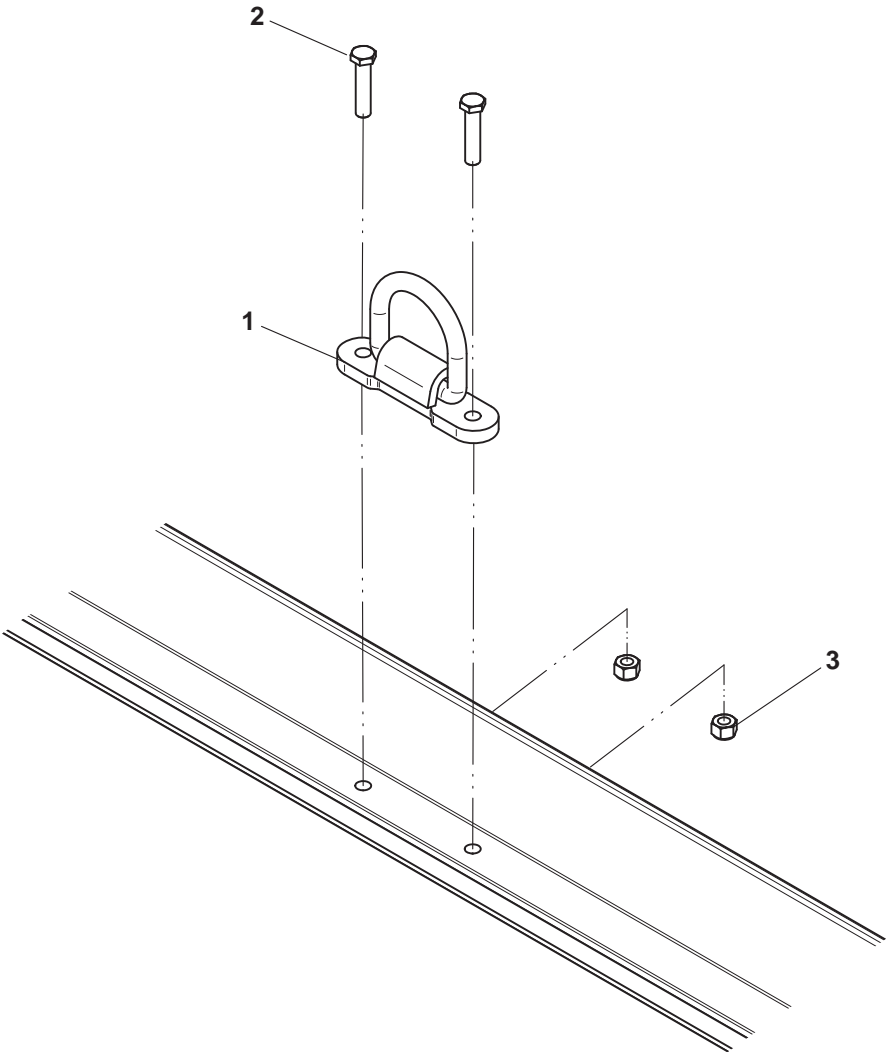

REMOTE CONTROL OPERATION(S)

ITEM	PART NO.	DESCRIPTION	QTY	ITEM	PART NO.	DESCRIPTION	QTY
1	7005000003	Linear Actuator 12V	1*	19	4706005396	Plate (4 & 5 remote operation)	1
2	4706005361	Plate	2	20	7114100818	Capscrew, #10-24NC x 1.00" (4 & 5 remote operation)	4
3	7115150864	Carriage Bolt, 0.31"-18NC x 1.00"	4	21	7660102604	Locknut, #10-24NC (4 & 5 remote operations)	4
4	7950150161	Flatwasher, 0.31" ID	4	22	9295310018#	Transmitter (1 remote operation)	1
5	7660152601	Locknut, 0.31"-18NC	4		9295310020#	Transmitter (2 remote operations)	
6	4178000664	Bracket	1*		9295310019#	Transmitter (3 remote operations)	
7	4178000665	Bracket	1*		7295000099#	Transmitter (4 remote operations)	
8	4691000141	Pin (3, 4 & 5 section control valve)	1	23	7330000612	Decal - Controller Functions (4 & 5 remote operations)	1
	4691000373	Pin (6 section control valve)		24	7115150864	Carriage Bolt, 0.31"-18NC x 1.00"	2*
9	4211000001	Bushing	4*	25	7660152601	Locknut, 0.31"-18NC	2*
10	7950220141	Flatwasher, 0.75" ID	4				
11	7754000009	Retaining Ring	2				
12	7295000097	Controller (1 remote operation)	1				
	7295000078	Controller (2 remote operations)					
	7295000075	Controller (3 remote operations)					
	7295000099	Controller (4 remote operations)					
	7295000095	Controller (5 remote operations)					
13	4706003650	Plate	1				
14	7104100613	Screw, #10-32NF x 0.34"	4				
15	7661000007	Wellnut, #10-32NF	4				
16	7115140650	Capscrew, 0.25"-20NC x 0.75" (1, 2 & 3 remote operations)	2				
	7115140650	Capscrew, 0.25"-20NC x 0.75" (4 & 5 remote operations)	5				
17	7950140141	Flatwasher, 0.25" ID (1, 2 & 3 remote operations)	2				
	7950140141	Flatwasher, 0.25" ID (4 & 5 remote operations)	5				
18	7660142601	Locknut, 0.25"-20NC (1, 2 & 3 remote operations)	2				
	7660142601	Locknut, 0.25"-20NC (4 & 5 remote operation)	5				

* quantities are for 1 remote operation, adjust quantities for 2, 3, 4 & 5 remote operations

included with Controller, item #12

REMOTE CONTROL OPERATION(S)

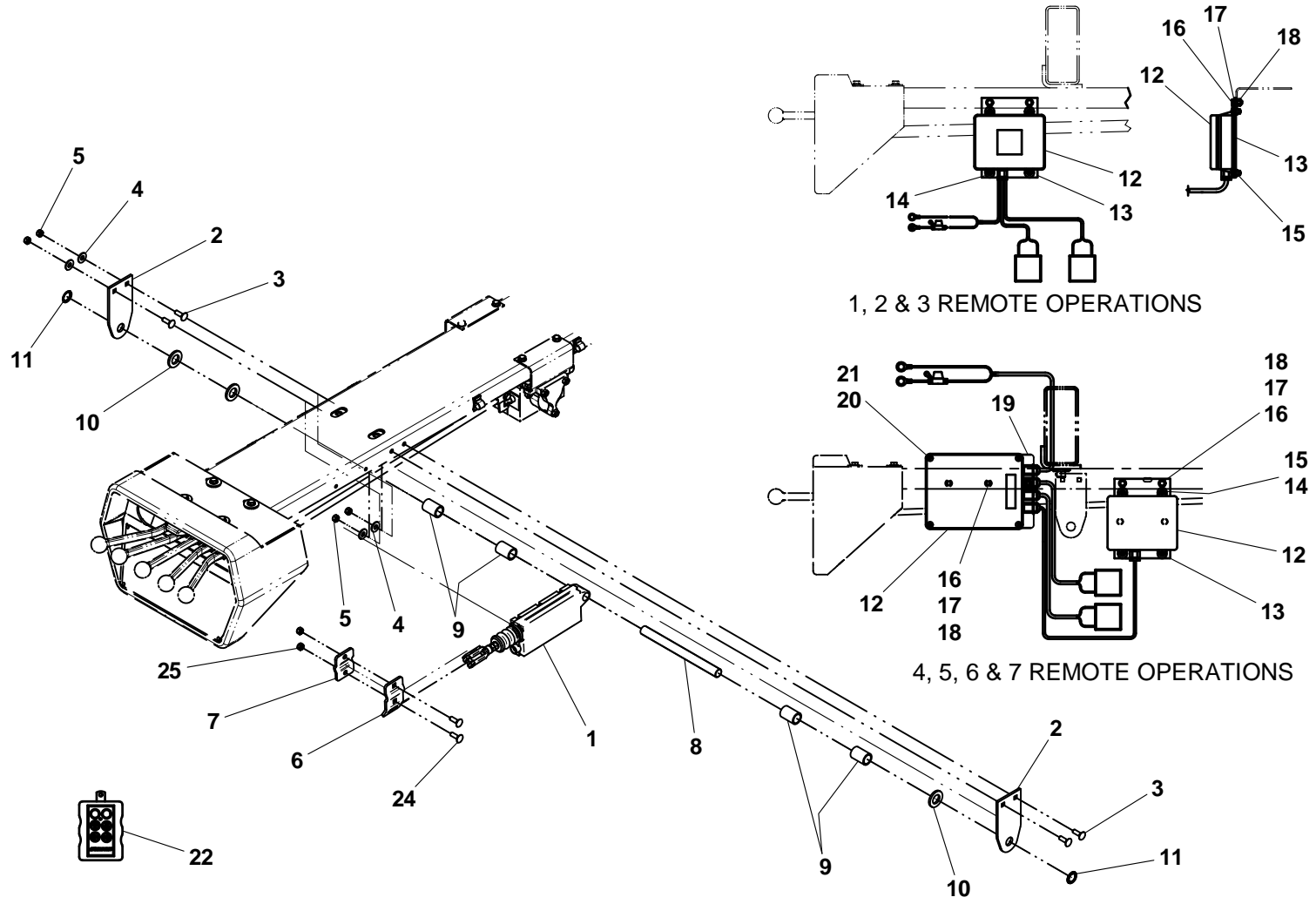

1, 2 & 3 REMOTE OPERATIONS

4, 5, 6 & 7 REMOTE OPERATIONS

One Remote Operaton shown

Item #23, Decal- Controller Functions, not shown

REMOTE THROTTLE CONTROL

ITEM	PART NO.	DESCRIPTION	QTY
1	7346000208	Pressure Switch	1
2	7552000241	Harness	1
3	7443000427*	Check Valve	1
4	7445060643*	Adapter	1

* also available in Check Valve w/ Adapter, P/N 7443000428.

REMOTE THROTTLE CONTROL

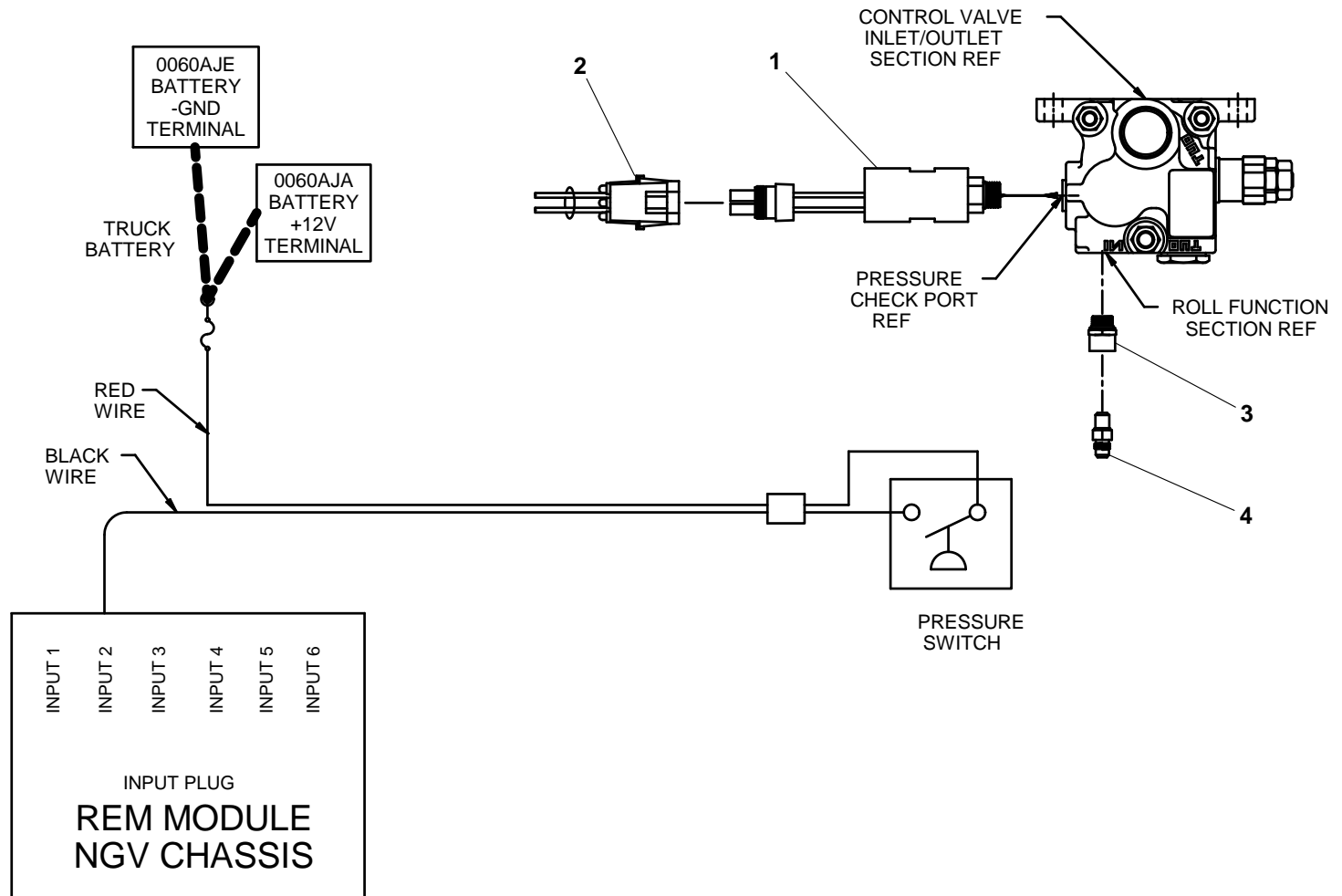

GLAD HANDS AND 7- WAY CONNECTOR

ITEM	PART NO.	DESCRIPTION	QTY
1	4178000666*	Bracket	1
2	7115181464*	Carriage Bolt, 0.50"-13NC x 1.75"	2
3	7660182601*	Locknut, 0.50"-13NC	2
4	7346000055+	Electrical Receptacle 7-way Connect	1
5	7346000078+	Electrical Boot	1
6	7111150813+	Capscrew, 0.31"-18NC x 1.00"	2
7	7660152601+	Locknut, 0.31"-18NC	2
8	7346000132	Electrical Adapter 7 to 4 way	1
9	7346000157	Electrical Adapter 7 to 6 way	1
10	7312000015^	Gladhand	1
11	7312000016^	Gladhand	1
12	7446502518^	Bulkhead Fitting	2
13	7446382506^	Connector	2
14	7577000145^	Seal Kit Gladhand	1
15	7565000014^	Airline Tubing	50 ft
16	7312000013^	Union	2

* also available in Bracket Install Glad Hands and 7 Way, P/N 2178000037

+ also available in Electrical Install 7 Way Connector, P/N 2346000008

^ also available in Glad Hand Install, P/N 2002000016

GLAD HANDS AND 7- WAY CONNECTOR

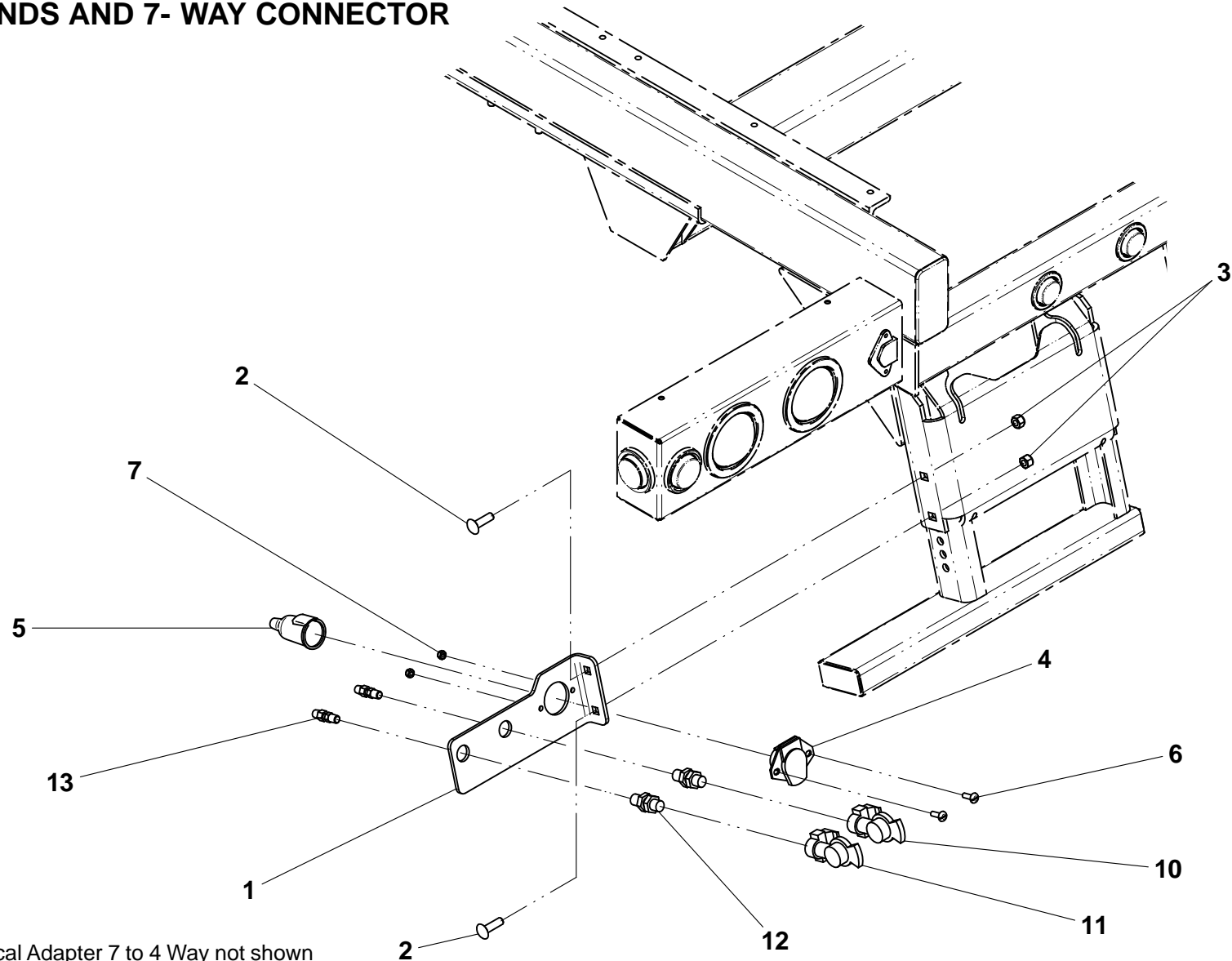

Item #8 Electrical Adapter 7 to 4 Way not shown
Item #9 Electrical Adapter 7 to 6 Way not shown

AIR SUPPLY DISCONNECT

ITEM	PART NO.	DESCRIPTION	QTY
1	7312000017	Coupling	1
2	7445080853	Elbow	1
3	7446502518	Bulkhead Fitting	1
4	7443000111	Elbow	1
5	7446382506	Connector	1
6	7565000014	Airline Tubing	32 ft
7	7935000120	Air Valve	1
8	7443000154	Bushing	1
9	7443000156	Nipple	1
10	7894000031	Cable Tie	6
11	7443000366	Fitting	1

AIR SUPPLY DISCONNECT

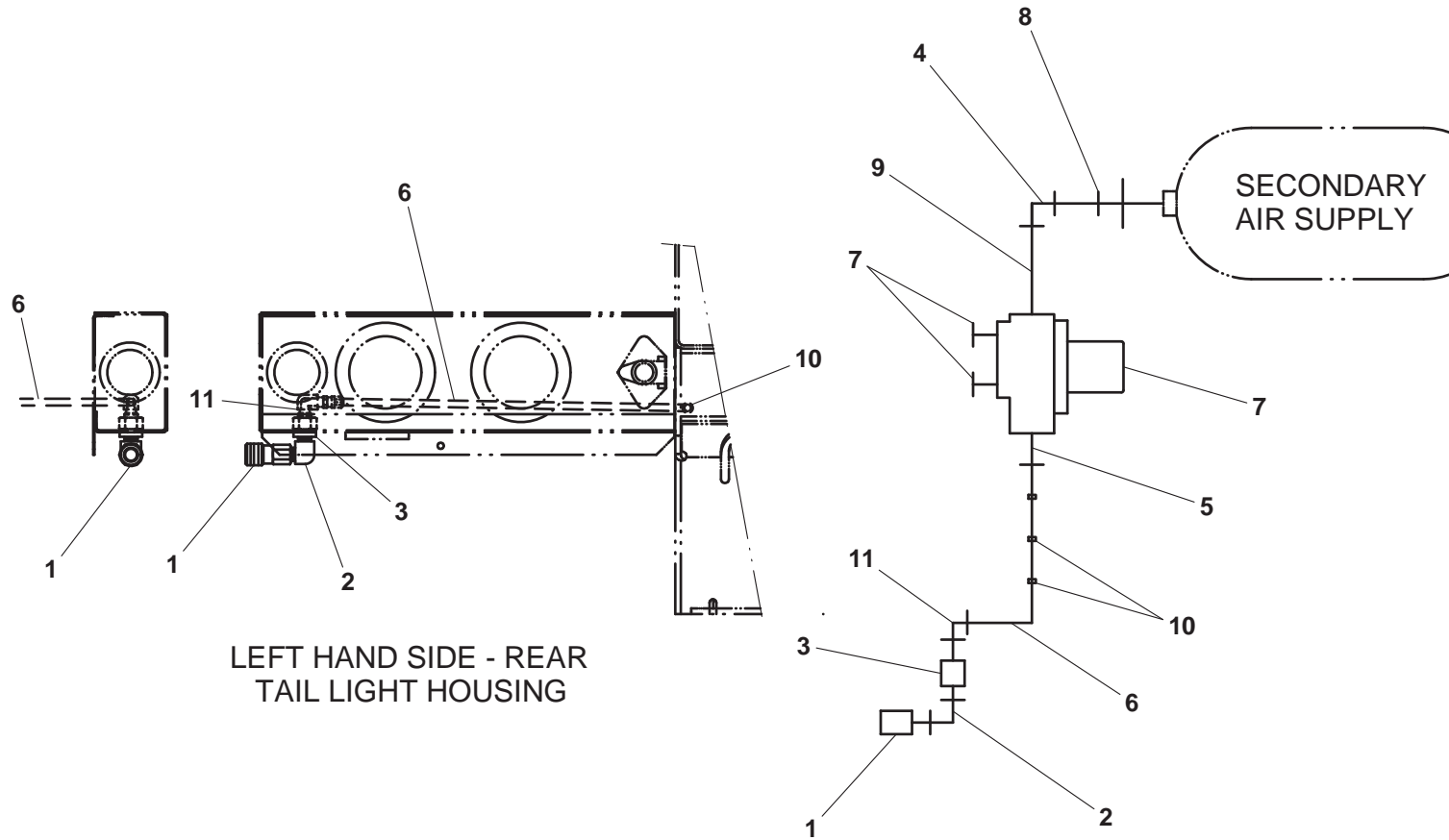

JUMP START KIT

ITEM	PART NO.	DESCRIPTION	QTY
1	7002000386	Jump Start Plug (IHC & Other)	1
	7002000385	Jump Start Plug (Ford & Chevy)	
2	4178000372	Bracket (Ford & Other)	1
	4178000202	Bracket (Chevy)	
3	4178000203	Bracket (Chevy)	1
	4706003210	Plate (Other)	
4	7110140605	Capscrew, 0.25"-20NC x 0.75" (Ford, Chevy & Other)	1
5	7950140161	Flatwasher, 0.25" ID (Ford & Other)	1
	7950140161	Flatwasher, 0.25" ID (IHC)	2
	7950140161	Flatwasher, 0.25" ID (Chevy)	3
6	7660142600	Locknut, 0.25"-20NC (Ford, Chevy & Other)	1
	7660142600	Locknut, 0.25"-20NC (IHC)	2
7	7115151064	Carriage Bolt, 0.31"-18NC x 1.25" (Other)	2
8	7950150161	Flatwasher, 0.31" ID (Other)	2
9	7660152601	Locknut, 0.31"-18NC (Other)	2
10	7115141450	Capscrew, 0.25"-20NC x 1.75" (IHC)	1
11	7115141650	CapScrew, 0.25"-20NC x 2.00" (IHC)	1
12	7660140000	Hex Nut, 0.25"-20NC (IHC)	1
	7660140000	Hex Nut, 0.25"-20NC (Chevy)	2
13	7111140850	Capscrew, 0.25"-20NC x 1.00" (Chevy)	2
14	7115181050	Capscrew, 0.50"-13NC x 1.25" (Chevy)	1
15	7950180153	Flatwasher, 0.50" ID (Chevy)	1
16	7660180000	Hex Nut, 0.50"-13NC (Chevy)	1

JUMP START KIT

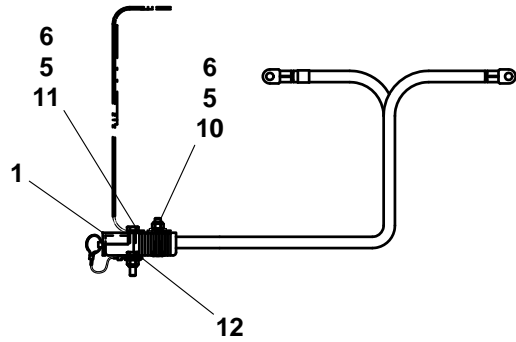

IHC FRONT BUMPER

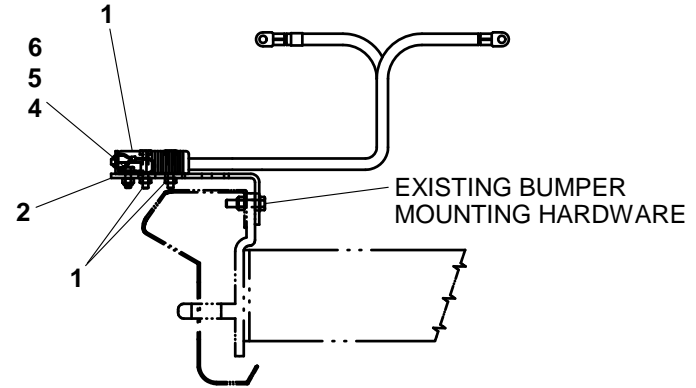

FORD FRONT BUMPER

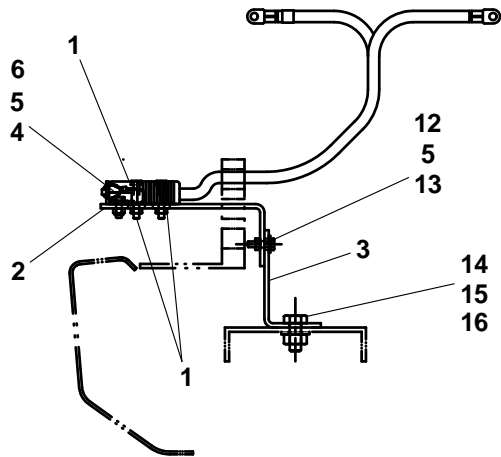

CHEVY FRONT BUMPER

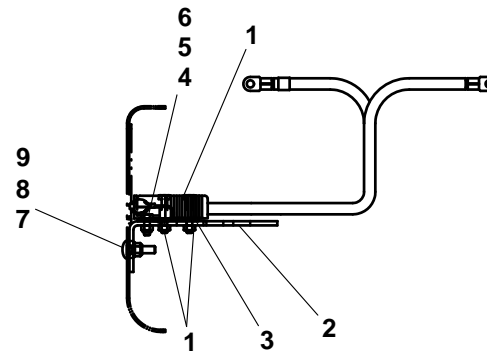

ALL OTHER FRONT BUMPERS

FOLDING DECK LADDER

ITEM	PART NO.	DESCRIPTION	QTY
1	3178000321	Bracket Weld	1
2	3002000009	Ladder Top Weld	1
3	3002000008	Ladder Bottom Weld	1
4	7114181418	Capscrew, 0.50"-13NC x 1.75"	4
5	7950180141	Flatwasher, 0.50" ID	12
6	7660182601	Locknut, 0.50"-13NC	4
7	7115180606	Shoulder Bolt, 0.50"-13NC x 0.75"	2
8	7950160141	Flatwasher, 0.38" ID	2
9	7660162601	Locknut, 0.38"-16NC	2

FOLDING DECK LADDER

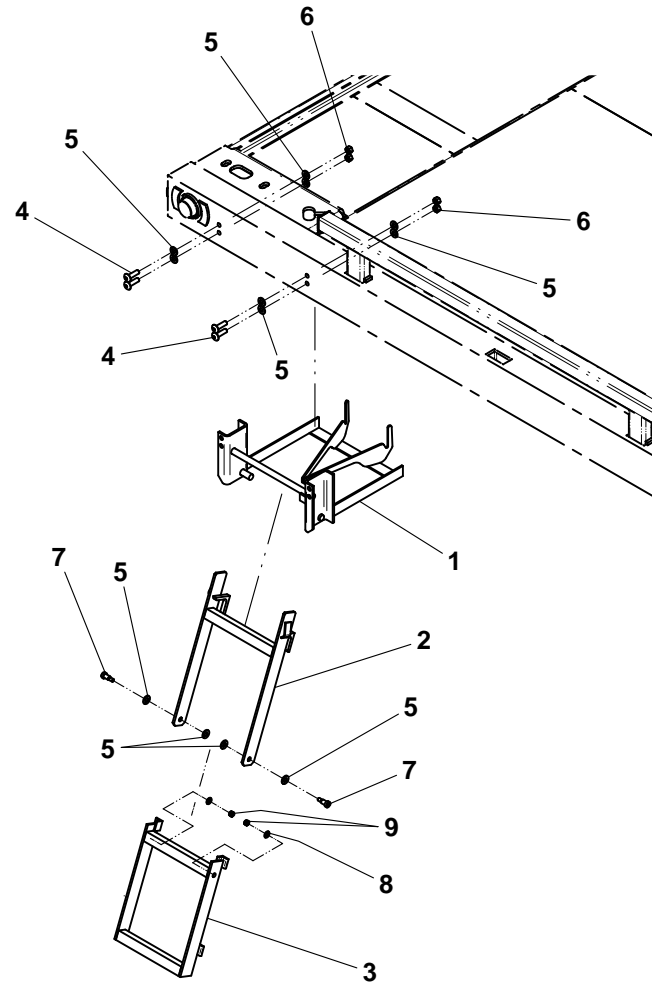

CHAIN AND STRAPS

ITEM	PART NO.	DESCRIPTION	QTY
1	7262000022*	Winch V-Chain	1
2	7262000059*	Front Tie-Down Chain	2
3	7894000019*	Rear Tie-Down Strap	2
4	7894000020*	Rear Tie Down Ratchet	2
5	7262000040	Wheel Lift Chain	2
6	7894000034^	Wheel Lift Tire Strap	2
7	7262000010	Towbar Chain (3,500 lb towbar)	2
8	7262000011	Towbar Chain (5,000 lb towbar)	2
9	7262000014	Towbar Chain (5,000 lb towbar)	2
10	7115181664	Carriage Bolt, 0.50"-13NC x 2.00"	2
11	7660180001	Nut, 0.50"-13NC	2
12	7660182601	Locknut, 0.50"-13NC	2

* also available in Deck Chain / Tie-Down Kit, P/N 7577000223

^ also available in Wheel Lift Tie-Down Strap & Ratchet Kit, P/N 7577000242

CHAIN AND STRAPS

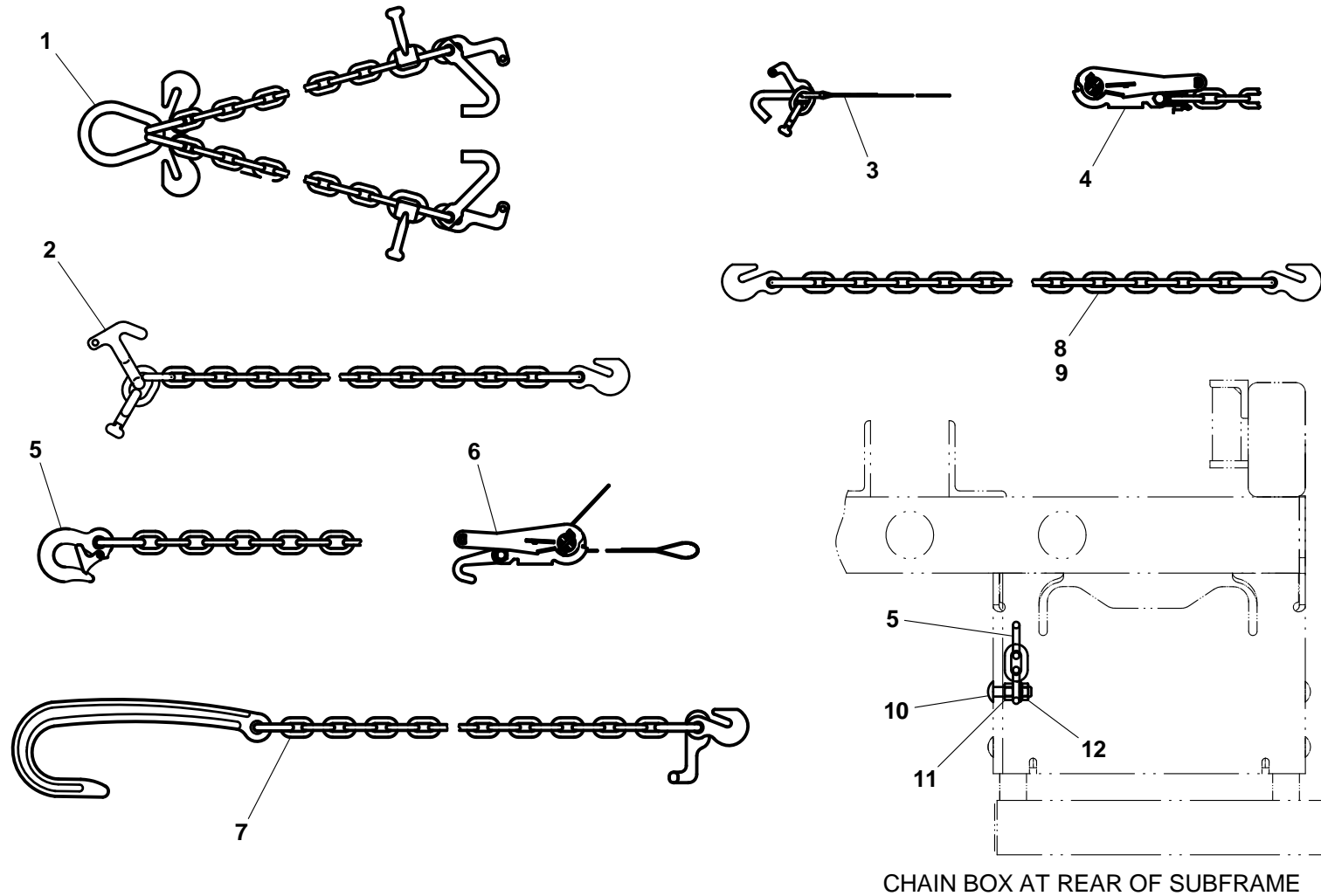

DECALS

ITEM	PART NO.	DESCRIPTION	QTY
1	7330000167	Serial Number Tag	1
2	7330000338	Subframe / Patent Tag	1
3	7330000502	Decal - Slide Pad / Pivot Joint	1
4	7330000376	Structural Rating Placard	1
5	7330000275	Decal - Operator's Pre-Checklist	1
6	7330000242	Decal - Free Spool (bolt-on headboard)	1
	7330000495	Decal - Free Spool (stationary headboard)	1
7	7330000478	Decal - Lubrication Chart	1
8	7330000012	Decal - Winch	1
9	7330000408	Jerr-Dan Nameplate	3
10	7330000143	Decal - Made In The USA	1
11	7330000045	Decal - Align Arrow, White	2
12	7330000272	Decal - Oil Level	1
13	7330000330	Decal - Cable Track	1
14	7330000139	Decal - Checklist Reminder	1
15	7330000684	Decal - Safety	1
16	7330000683	Decal - Safety	2
17	7330000060	Decal - Wheel Lift Hitch	1
18	7330000391	Decal - Tow Boom Configuration	1
19	7330000274	Decal - Overloading Tow Option	1
20	7330000599	Decal - Pinch Point	3
21	7330000390	Decal - Stabilizer W/ 4,000 lb W/L	2
22	7759000004	Pop Rivet	12
23	9330740009	Decal Kit - Muncie PTO	1

DECALS

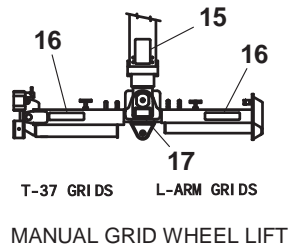
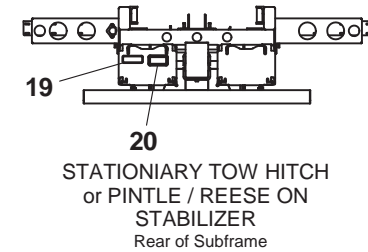
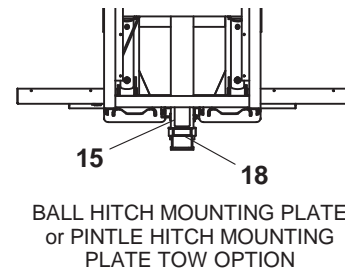
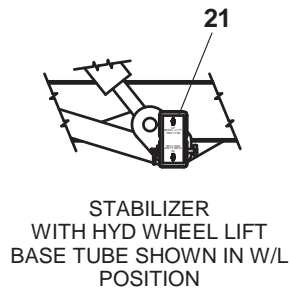
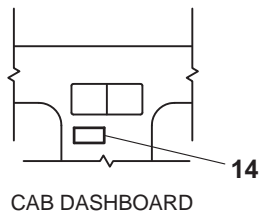
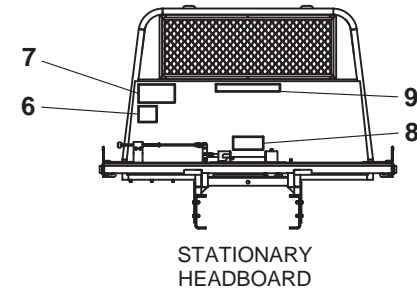
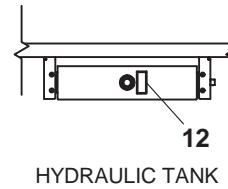
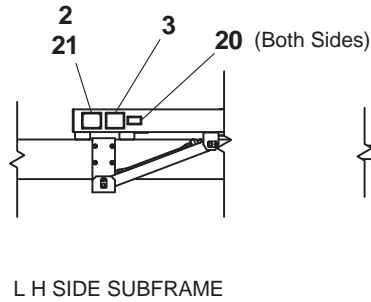
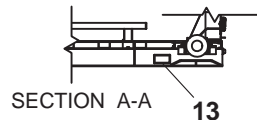
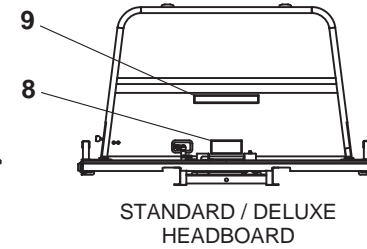
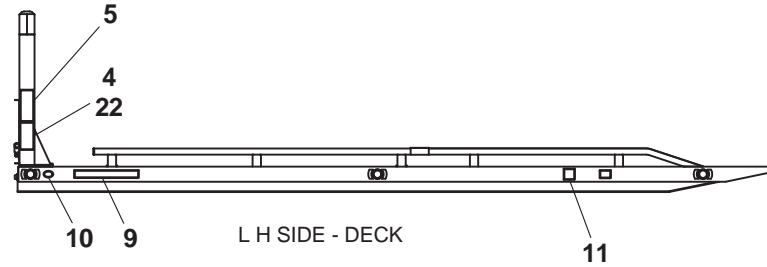
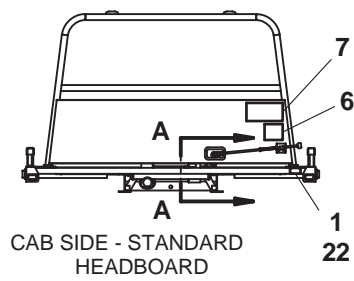

Item #23, Decal Kit, not shown

HYDRAULIC SCHEMATIC

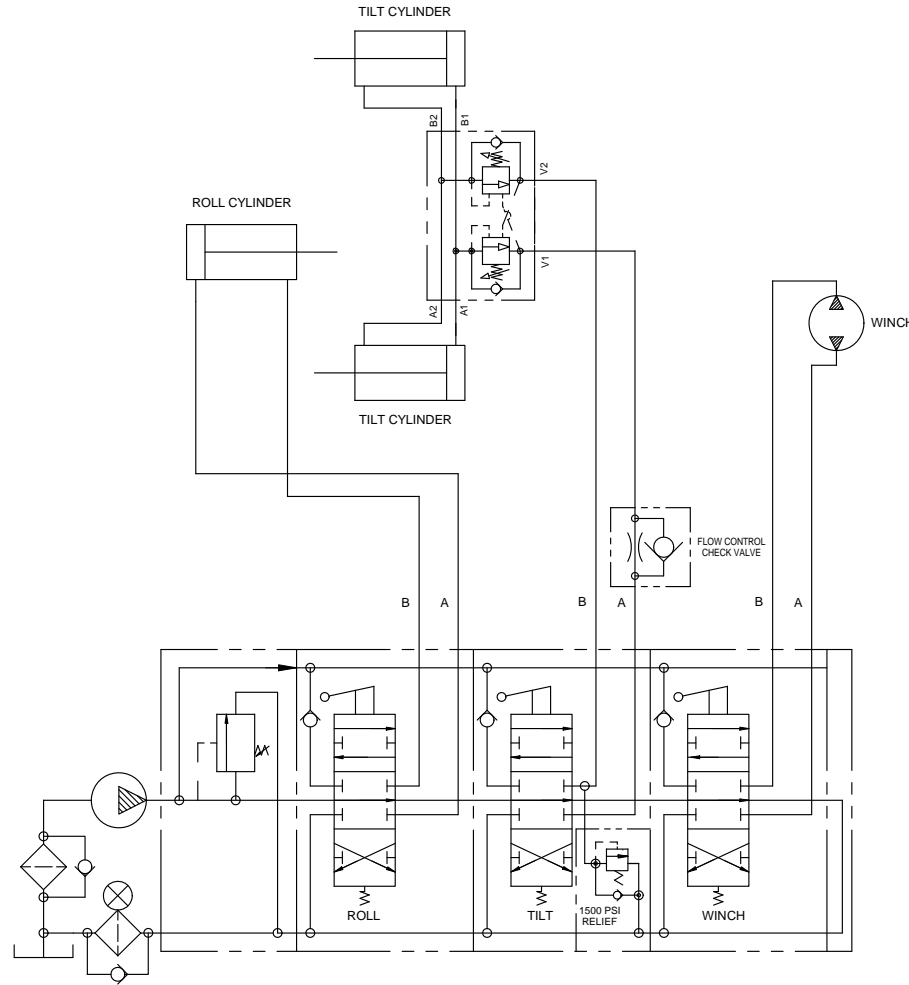

3 Bank Control Valve - No Tow Options

HYDRAULIC SCHEMATIC

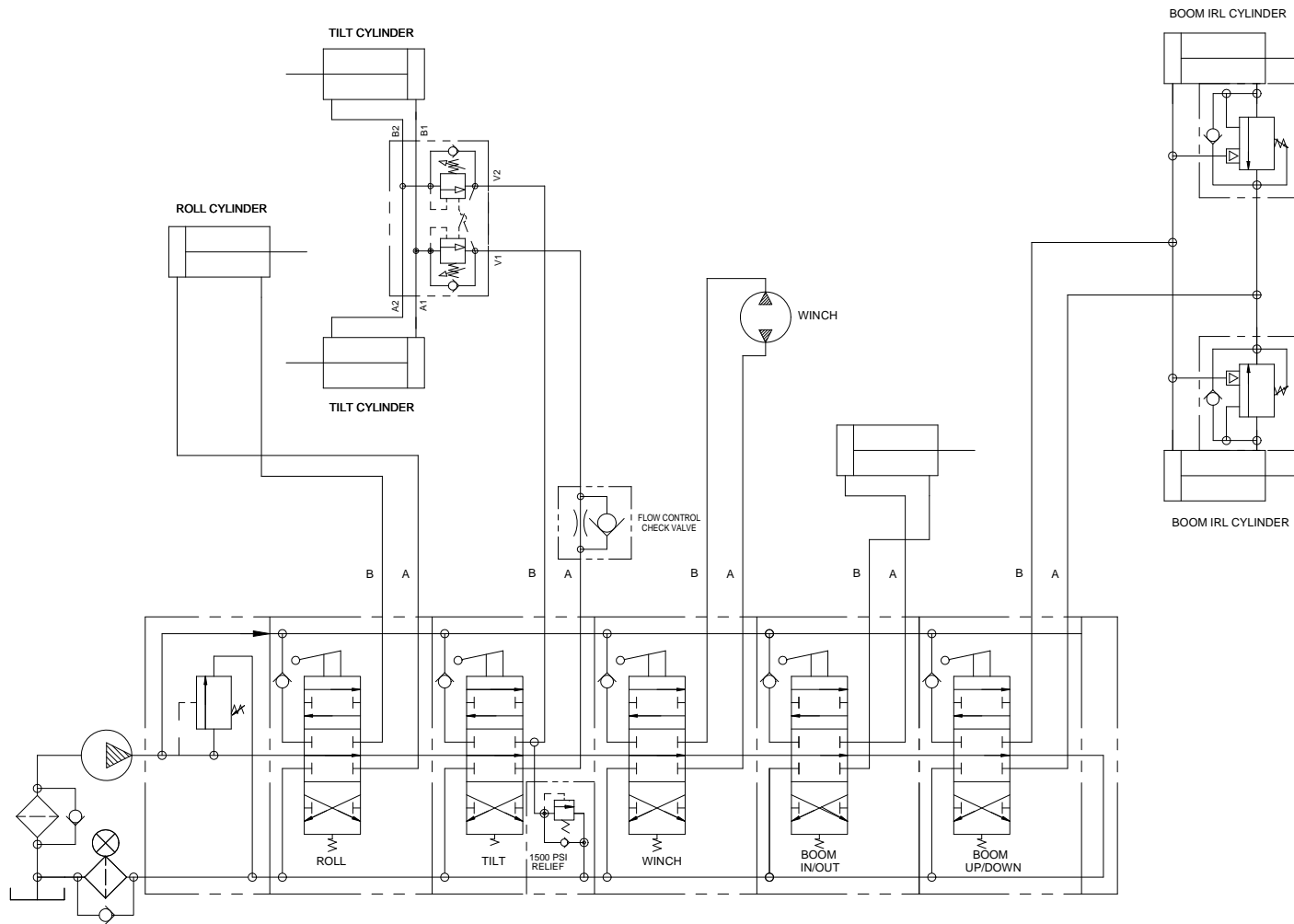

5 Bank Control Valve - IRL Tow Options

HYDRAULIC SCHEMATIC

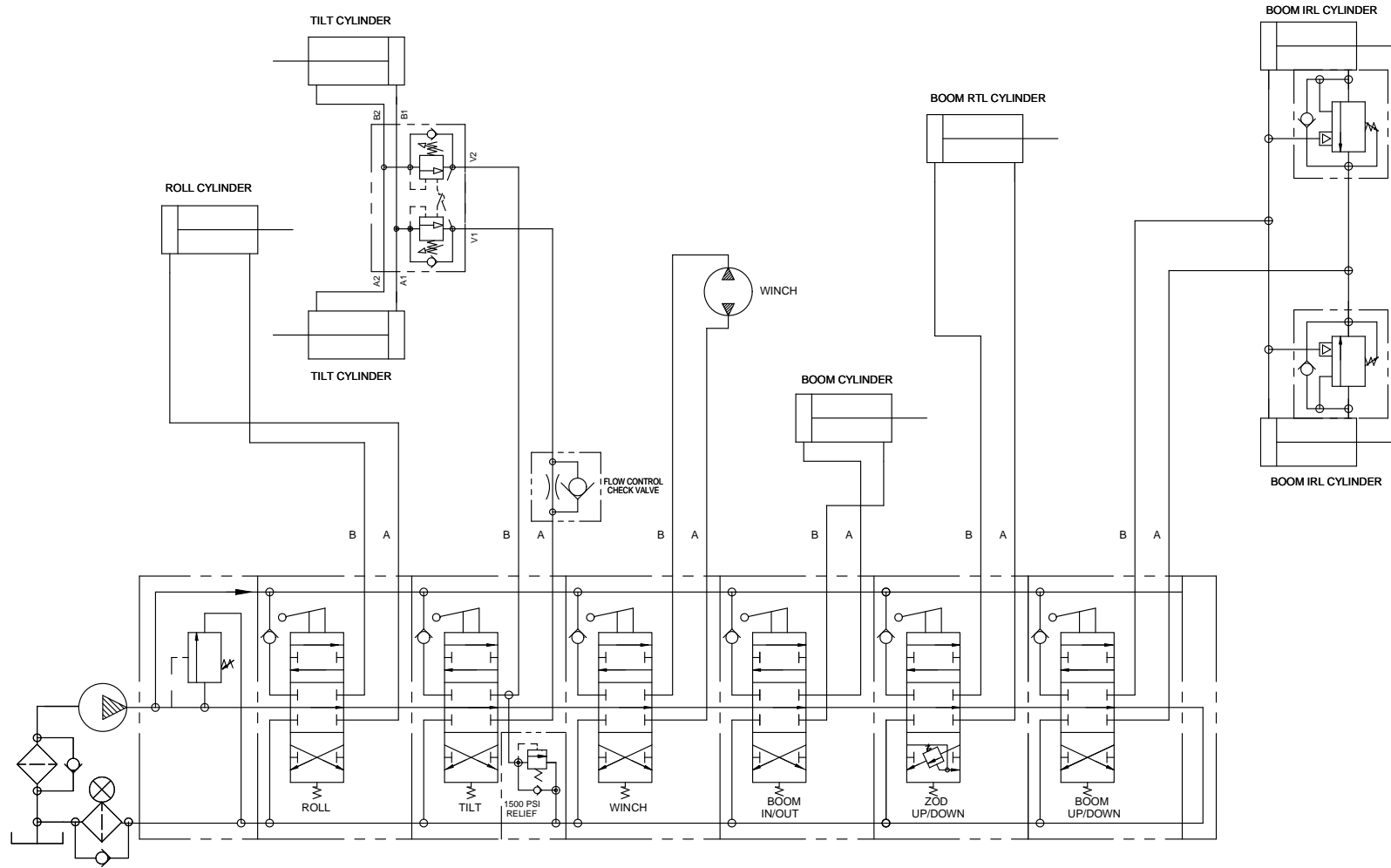

6 Bank Control Valve - ZOD Tow Option

HYDRAULIC SCHEMATIC

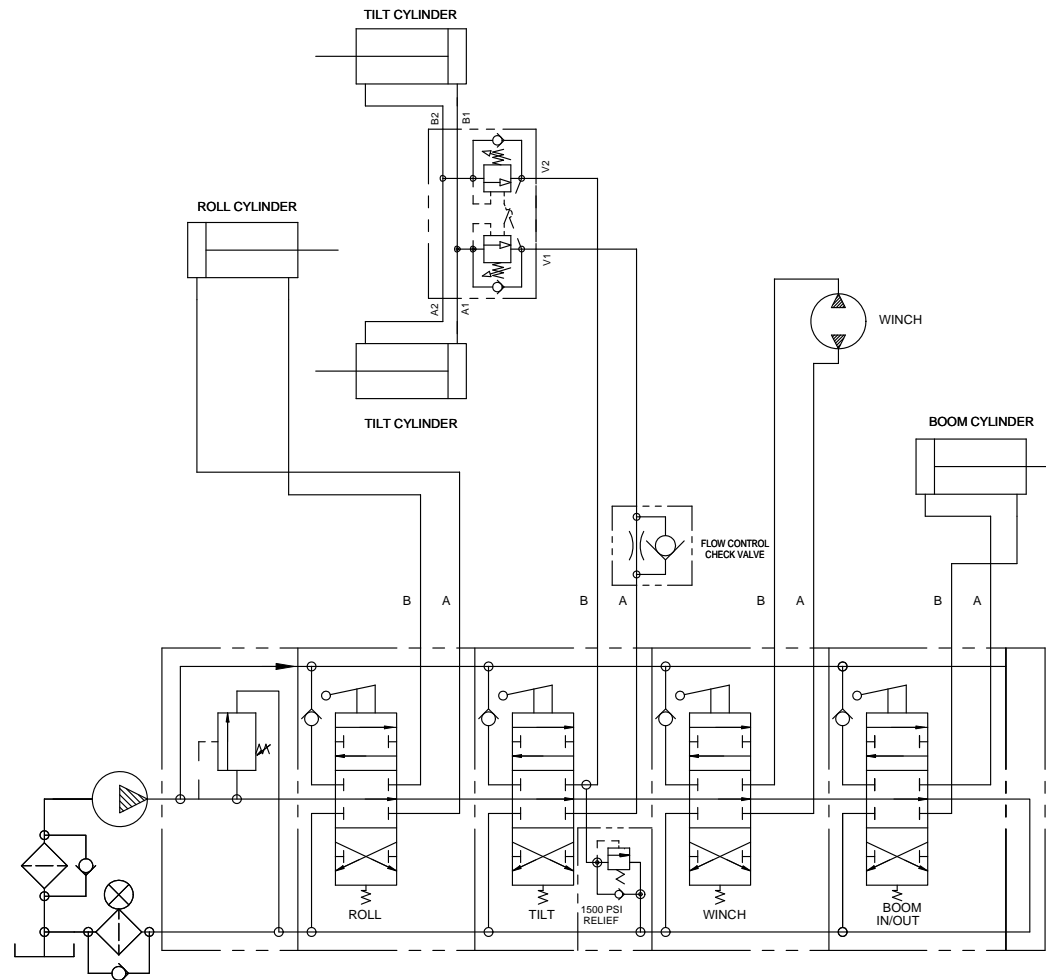

4 Bank Control Valve - Hydraulic Extended Boom Tow Options

HYDRAULIC SCHEMATIC

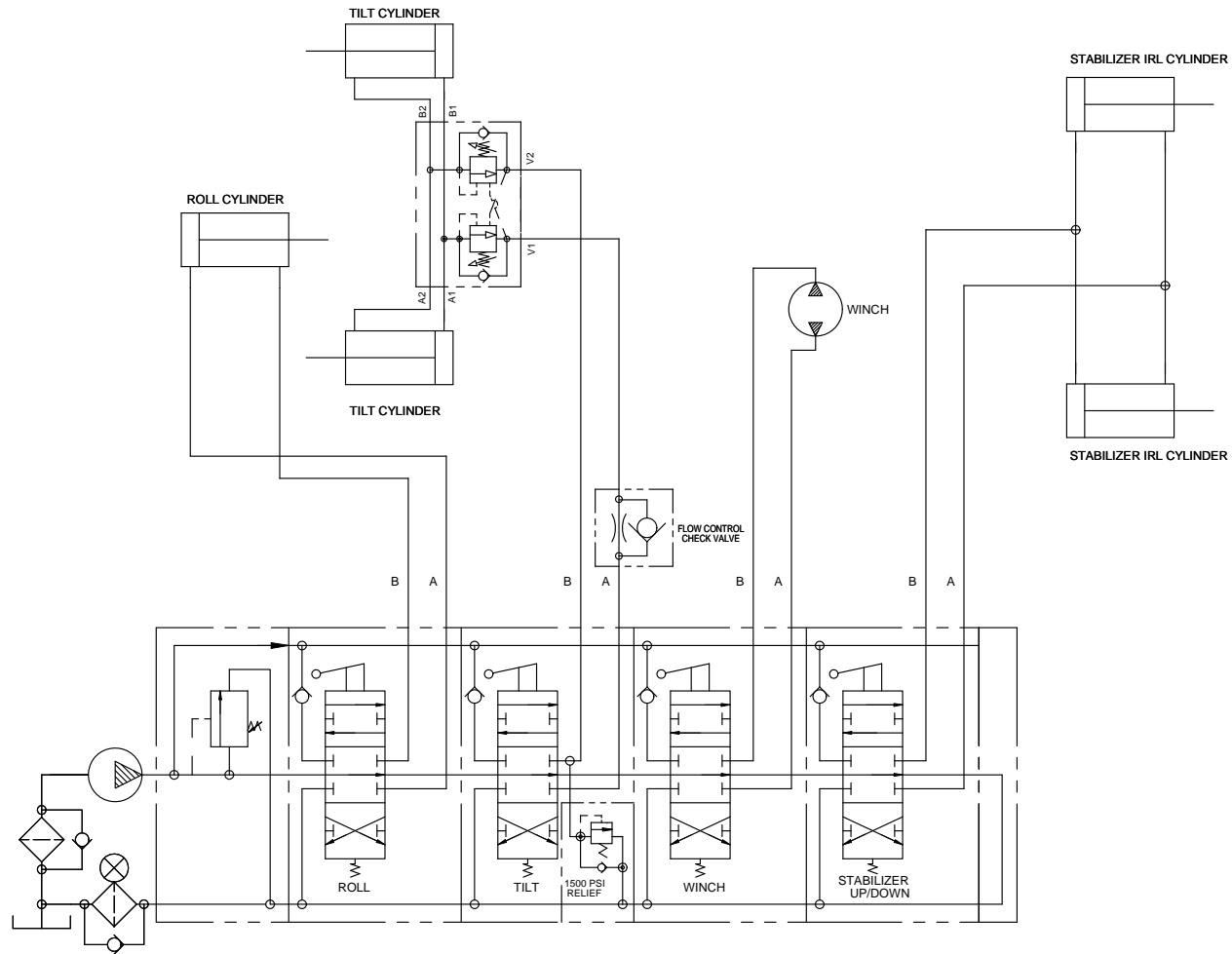

4 Bank Control Valve - Stabilizer Option

HYDRAULIC SCHEMATIC

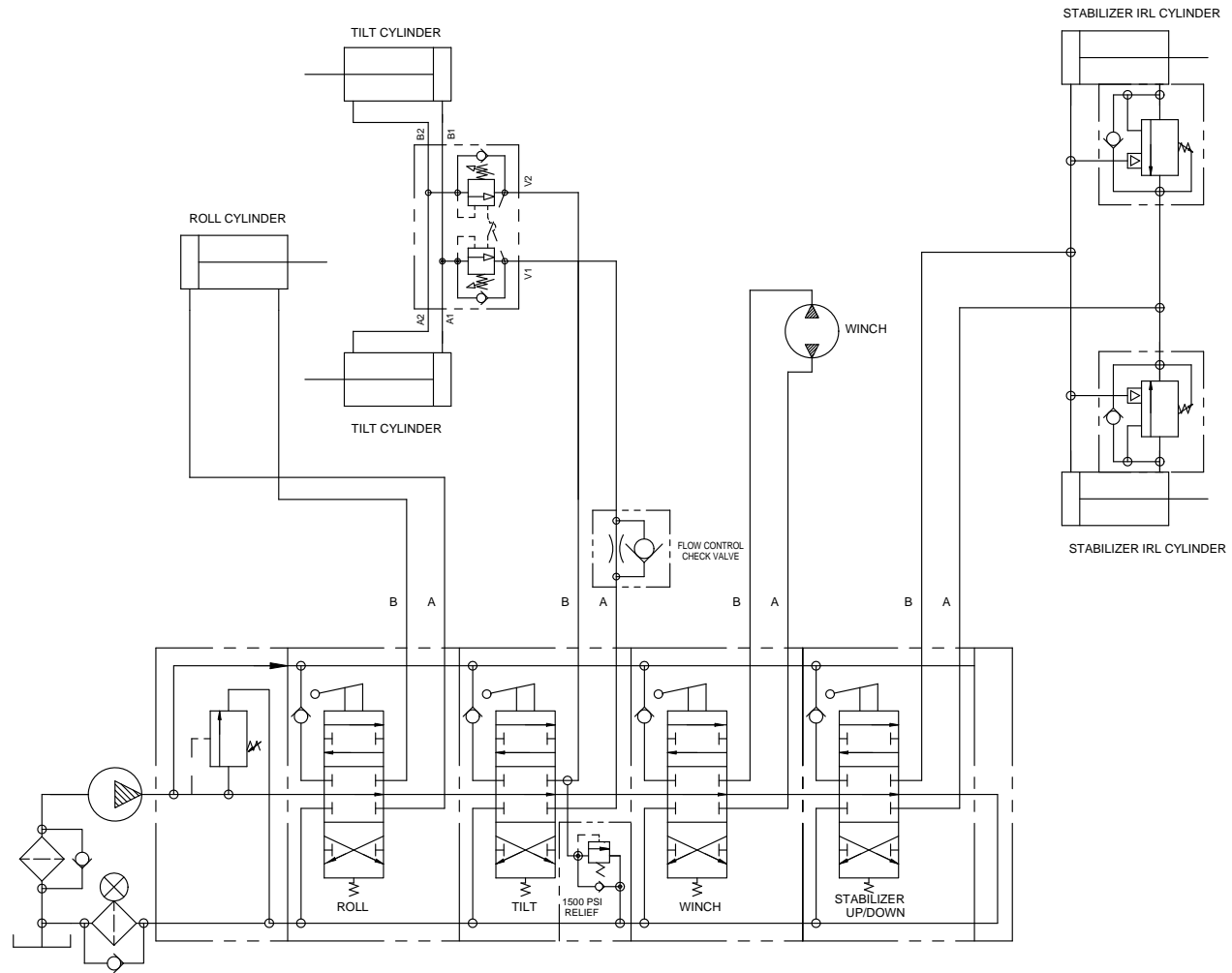

4 Bank Control Valve - Stabilizer with Tow Options

HYDRAULIC SCHEMATIC

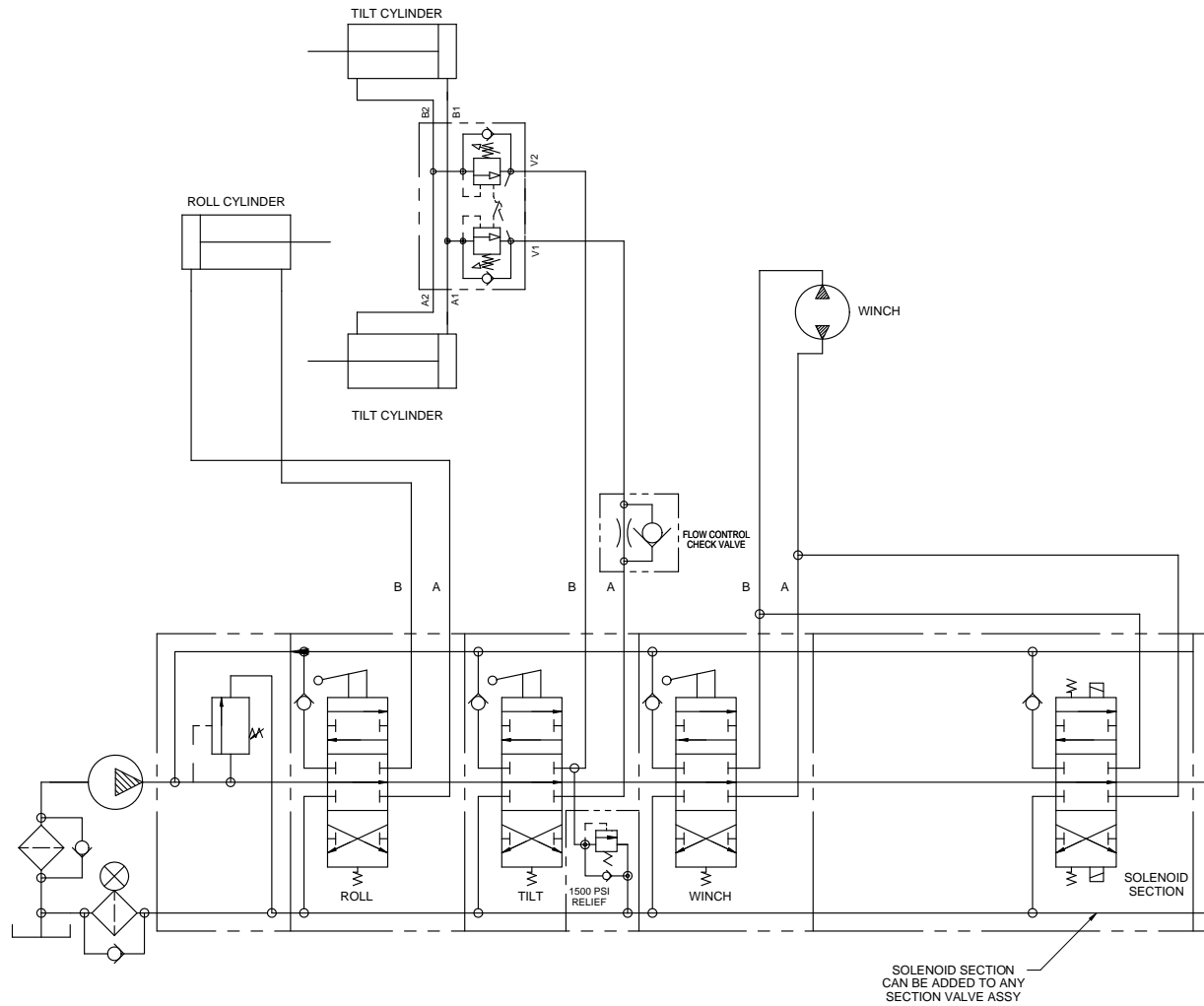

3 + 1 Bank Control Valve - Solenoid Section for Remote Control Winch

ELECTRICAL SCHEMATIC

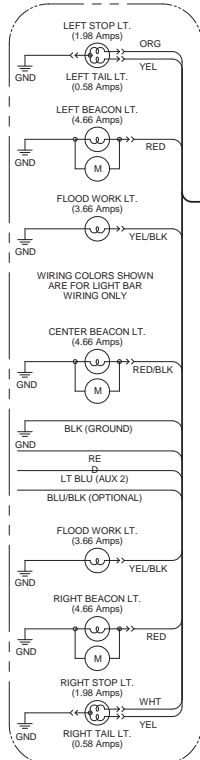

LIGHT BAR

CIRCUIT	COLOR	FUNCTION
1	WHITE	GROUND
2	BROWN	CLEARANCE
3	GREEN	R.H. STOP/TURN
4	YELLOW	L.H. STOP/TURN
5	BLACK	BACK-UP
6	BLUE	WORK LIGHTS (SUBFR)
7	VIOLET	WORK LIGHTS (LT BAR)
8	GRAY	BEACON (ROTATORS)
9	ORANGE	AUX1 (FLASHER)
10	LT BLUE/BLACK	OPT.
11	LT BLUE	AUX. 2

CODE
 BLK = BLACK
 BRN = BROWN
 BLU = BLUE
 GRN = GREEN
 RED = RED
 YEL = YELLOW
 LT = LIGHT
 ORG = ORANGE
 VLT = VIOLET
 WHT = WHITE

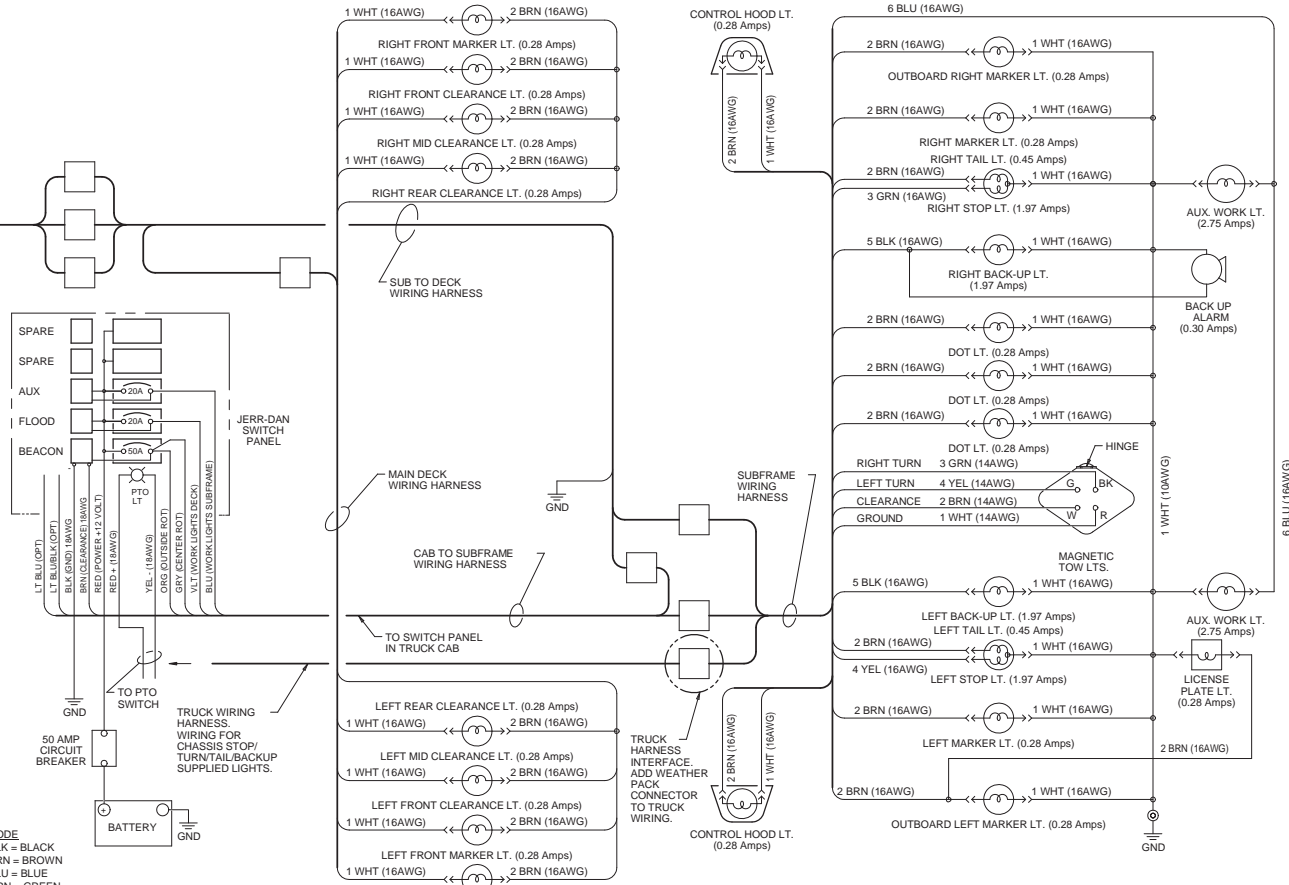

THIS PAGE INTENTIONALLY LEFT BLANK