

# HEAVY DUTY CARRIER PARTS MANUAL

# ***JERR-DAN***<sup>®</sup>

An Oshkosh Truck Corporation Company

1080 Hykes Road  
Greencastle, PA 17225  
Phone (717) 597-7111  
[www.jerr-dan.com](http://www.jerr-dan.com)

5-376-000091  
Rev 1 - March 01, 2007

© 2007 Jerr-Dan Corporation. All Rights Reserved.

This manual covers the following Jerr-Dan Models:

\_10T2B - 10 Ton Steel Wrangler

\_15T2B - 15 Ton Steel Wrangler

\_10TRB - 10 Ton Steel Transporter

\_15TRB - 15 Ton Steel Transporter

Jerr-Dan Corporation strives to provide information that is accurate, complete and useful. Descriptions and illustrative material contained within this manual are as accurate as known at the time of publication and are subject to change, without notice, as a result of continuous product improvements. Jerr-Dan reserves the right to amend the information in this document at any time without prior notice.

Information contained in this manual reflects how this vehicle was built at the factory. Modifications or additions by the distributor or owner are not reflected in this manual.

This parts manual does not include service parts information for the commercial chassis (IHC, Ford, GM, etc.). This parts information is provided by the chassis manufacturer.

When ordering parts, please refer to your unit's Sales Order Number, Serial Number and Model Number. This information can be found on the aluminum tag riveted to the front left corner of the deck as shown below:

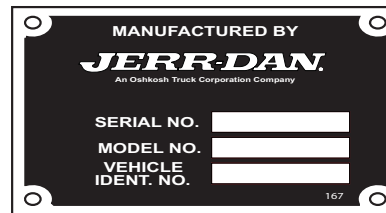

Additional or replacement manuals can be ordered by calling Jerr-Dan Parts at 717-597-7111. Price and availability will be quoted at time of the request.

Please report comments and/or errors by contacting Jerr-Dan Corporation's Technical Publications Department by e-mail at [technicalpublications@jerr-dan.com](mailto:technicalpublications@jerr-dan.com) or by FAX on 717-593-2362.

Manufactured under one or more of the following patents: 5,044,865; 5,370,196; 5,575,606; 5,697,741; 6,231,294 B1; and 6,447,239 B2 with other Patents Pending.

Jerr-Dan and the Jerr-Dan logo are registered trademarks of Jerr-Dan Corporation, Greencastle, PA USA.

The material in this document is confidential and the property of Jerr-Dan Corporation. No part of this document may be photocopied, reproduced or translated to another language without the express written consent of Jerr-Dan Corporation.

# INDEX

DESCRIPTION	PAGE	DESCRIPTION	PAGE
Deck - Steel Wrangler (_10T2B & _15T2B) .....	4 - 5	Ball Hitch Mounting Plate - Hydraulic Extend .....	92 - 93
Deck - Steel Transporter (_10TRB & _15TRB) .....	6 - 7	Ball Hitch Mounting Plate - Manual Extend .....	94 - 95
Deluxe Headboard .....	8 - 9	Pintle Hitch Mounting Plate - Hydraulic Extend .....	96 - 97
Stationary Headboard .....	10 - 11	Pintle Hitch Mounting Plate - Manual Extend .....	98 - 99
Wheel Well Covers .....	12 - 13	Towbar - IRL .....	100 - 101
Winch Free Spool (12,000 lb Worm Gear Winch) .....	14 - 15	Towbar - Hydraulic Extend .....	102 - 103
Worm Gear Winch (12,000 lb) .....	16 - 17	Roll Cylinder Assembly .....	104 - 105
Worm Gear Winch (20,000 lb) with Air Free Spool .....	18 - 19	Tilt Cylinder Assembly .....	106 - 107
Worm Gear Winch (12,000 lb) Cable Roller Guide / Tensioner Plate .....	20 - 21	Wheel Lift Extend Cylinder Assembly .....	108 - 109
Worm Gear Winch (20,000 lb) Cable Roller Guide / Tensioner Plate .....	22 - 23	IRL Cylinder Assembly .....	110 - 111
Subframe .....	24 - 25	Stabilizer Cylinder Assembly .....	112 - 113
Hold Down .....	26 - 27	Tow Option Hydraulic Extend Cylinder Assembly .....	114 - 115
Slide Pad .....	28 - 29	Stabilizer Cylinder Assembly .....	116 - 117
Mud Flap .....	30 - 31	Lightbars .....	118 - 119
Final Assembly .....	32 - 33	Switch Panels .....	120 - 121
Hydraulic Reservoir and Toolbox / Basket .....	34 - 37	Work Lights .....	122 - 123
Toolbox .....	38 - 39	Bolt-On D-Rings .....	124 - 125
Toolbox Shelf .....	40 - 41	Remote Control Operation(s) .....	126 - 127
Toolbox Light .....	42 - 43	Remote Throttle Control .....	128 - 129
Dual Controls - 3 Bank .....	44 - 45	Glad Hands and 7- Way Connector .....	130 - 131
Dual Controls - 4 Bank .....	46 - 47	Air Supply Disconnect .....	132 - 133
Dual Controls - 5 Bank .....	48 - 49	Jump Start Kit .....	134 - 135
Hydraulic Components - Standard .....	50 - 51	Folding Deck Ladder .....	136 - 137
Hydraulic Components - Standard (Hose Track) .....	52 - 53	Chains and Straps .....	138 - 139
Hydraulic Components - Hose Routing / Mounting .....	54 - 55	Decals .....	140 - 141
Hydraulic Components - IRL Wheel Lift w/ Man Grids or IRL Ball / Pintle Hitch Mtg Plt .....	56 - 57	Hydraulic Schematic .....	141 - 147
Hydraulic Components - Stabilizer .....	58 - 59	Electrical Schematic .....	148
Hydraulic Components - Stabilizer w/ Reese Hitch Receiver or Pintle Hitch Mtg Plate .....	60 - 61		
Hydraulic Components - Stabilizer w/ Hydraulic Extend Pintle Mounting Plate .....	62 - 63		
Hydraulic Components - Stabilizer w/ IRL Wheel Lift .....	64 - 65		
Hydraulic Components - IRL Towbar .....	66 - 67		
Hydraulic Components - Hydraulic Extend Tow Option .....	68 - 69		
Electrical Components - Standard w/ Bolt-On Headboard .....	70 - 71		
Electrical Components - Standard w/ Stationary Headboard .....	72 - 73		
Electrical Components - Optional .....	74 - 75		
IRL Wheel Lift .....	76 - 77		
Manual L-Arm Wheel Lift Grid .....	78 - 79		
Manual T37 Pivoting Wheel Lift Grid .....	80 - 81		
Hydraulic Rear Dock Stabilizer .....	82 - 83		
Stabilizer w/ Reese Hitch Receiver .....	84 - 85		
Stabilizer w/ Manual Extend Pintle Hitch Mounting Plate .....	86 - 87		
Stabilizer w/ Hydraulic Extend Pintle Hitch Mounting Plate .....	88 - 89		
Stabilizer w/ Hydraulic Extend Wheel Lift .....	90 - 91		

**DECK - STEEL WRANGLER (\_10T2B & \_15T2B)**

ITEM	PART NO.	DESCRIPTION	QTY	ITEM	PART NO.	DESCRIPTION	QTY
1	3097000318	24' Deck - 95" wide, 12" X-mem spacing (10 Ton)	1		3097000328	28' Deck - 95" wide, 8" X-mem spacing (15 Ton)	
	3097000321	24' Deck - 95" wide, 8" X-mem spacing (10 Ton)			3097000331	28' Deck - 102" wide, 8" X-mem spacing (15 Ton)	
	3097000324	24' Deck - 102" wide, 12" X-mem spacing (10 Ton)		2	7493000009	Marker Light Grommet	6
	3097000327	24' Deck - 102" wide, 8" X-mem spacing (10 Ton)		3	7590000249	Marker Light - Amber (Std)	4
	3097000330	24' Deck - 95" wide, 8" X-mem spacing (15 Ton)		4	7590000239	Marker Light - Amber (LED)	
	3097000333	24' Deck - 102" wide, 8" X-mem spacing (15 Ton)		5	7590000245	Marker Light - Red (Std)	2
	3097000317	26' Deck - 95" wide, 12" X-mem spacing (10 Ton)		6	7590000238	Marker Light - Red (LED)	
	3097000320	26' Deck - 95" wide, 8" X-mem spacing (10 Ton)		7	7493000010	Marker Light Grommet	2
	3097000323	26' Deck - 102" wide, 12" X-mem spacing (10 Ton)		8	7590000250	Marker Light - Amber (Std)	2
	3097000326	26' Deck - 102" wide, 8" X-mem spacing (10 Ton)		9	7590000242	Marker Light - Amber (LED)	
	3097000329	26' Deck - 95" wide, 8" X-mem spacing (15 Ton)		10	7330000498	Reflector - Amber	8
	3097000332	26' Deck - 102" wide, 8" X-mem spacing (15 Ton)		11	7330000497	Reflector - Red	4
	3097000316	28' Deck - 95" wide, 12" X-mem spacing (10 Ton)		12		<i>Steel Tubular Removable Rails:</i>	
	3097000319	28' Deck - 95" wide, 8" X-mem spacing (10 Ton)		13	3729000126	Steel Rail, LH Front (24' deck)	1
	3097000322	28' Deck - 102" wide, 12" X-mem spacing (10 Ton)		14	3729000116	Steel Rail, LH Front (26' & 28' deck)	
	3097000325	28' Deck - 102" wide, 8" X-mem spacing (10 ton)		15	3729000126	Steel Rail, RH Front (24' deck)	1
				16	3729000121	Steel Rail, RH Front (26' & 28' deck)	
					3729000121	Steel Rail, LH Mid (26' & 28' deck)	1
					3729000116	Steel Rail, RH Mid (26' & 28' deck)	
					3729000129	Steel Rail, LH Rear (24' & 28' deck)	1
					3729000127	Steel Rail, LH Rear (26' deck)	
					3729000130	Steel Rail, LH Rear (26' deck)	
					3729000130	Steel Rail, RH Rear (24' & 28' deck)	1
					3729000128	Steel Rail, RH Rear (26' deck)	
					7120000005	Capscrew, 0.50"-13NC x 2.50" (24' deck)	12
					7120000005	Capscrew, 0.50"-13NC x 2.50" (26' & 28' deck)	14
					7701000033	End Cap (24' deck)	4
					7701000033	End Cap (26' & 28' deck)	6

# DECK - STEEL WRANGLER (\_10T2B & \_15T2B)

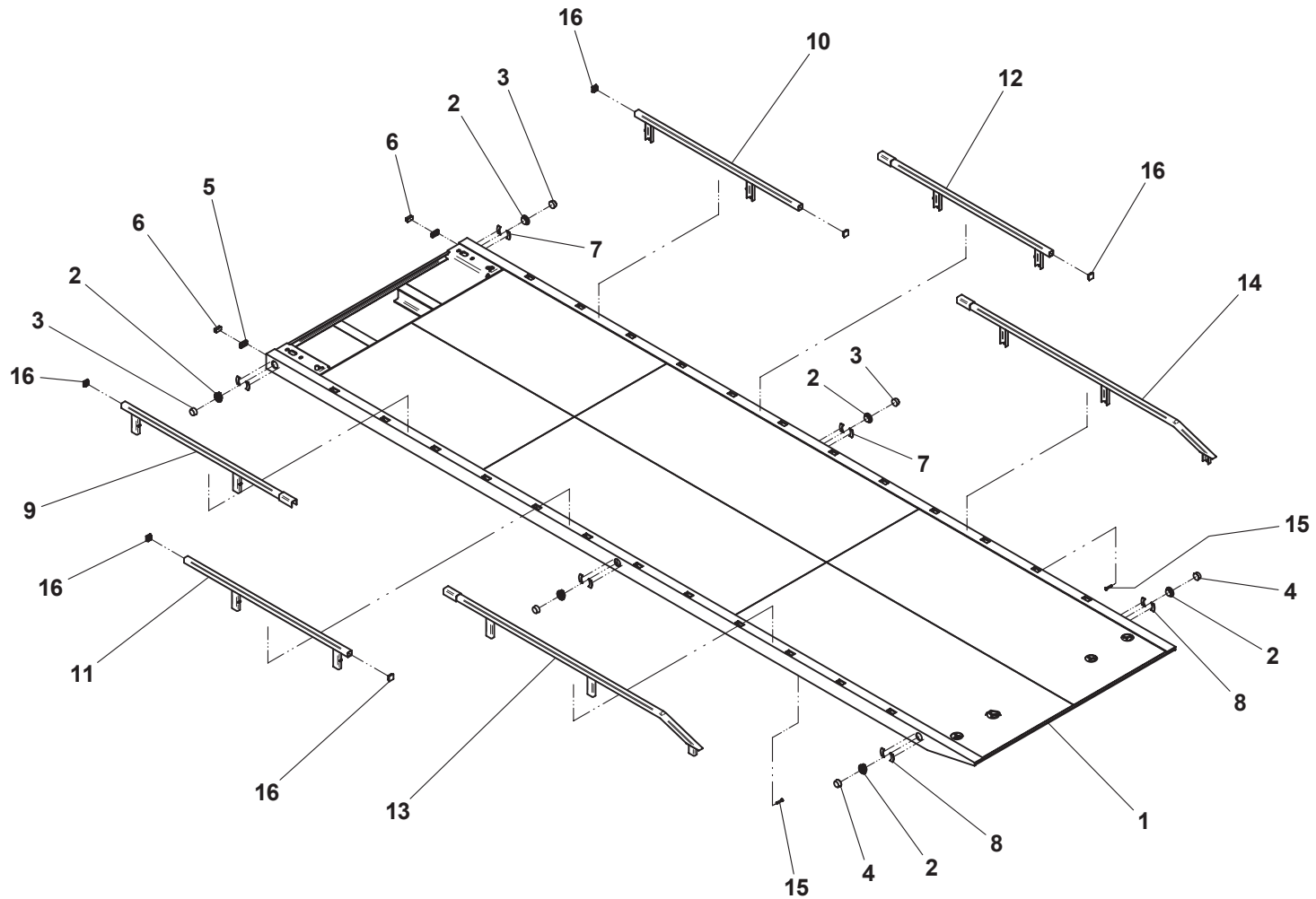

28' deck shown with removable steel rails

**DECK - STEEL TRANSPORTER (\_10TRB & \_15TRB)**

ITEM	PART NO.	DESCRIPTION	QTY	ITEM	PART NO.	DESCRIPTION	QTY
1	3097000306	24' Deck - 95" wide, 12" X-mem spacing (10 Ton)	1		3097000300	28' Deck - 95" wide, 8" X-mem spacing (15 Ton)	
	3097000303	24' Deck - 95" wide, 8" X-mem spacing (10 Ton)			3097000307	28' Deck - 102" wide, 8" X-mem spacing (15 Ton)	
	3097000315	24' Deck - 102" wide, 12" X-mem spacing (10 Ton)		2	7493000009	Marker Light Grommet	6
	3097000312	24' Deck - 102" wide, 8" X-mem spacing (10 Ton)		3	7590000249	Marker Light - Amber (Std)	4
	3097000299	24' Deck - 95" wide, 8" X-mem spacing (15 Ton)		4	7590000239	Marker Light - Amber (LED)	
	3097000309	24' Deck - 102" wide, 8" X-mem spacing (15 Ton)		5	7590000245	Marker Light - Red (Std)	2
	3097000305	26' Deck - 95" wide, 12" X-mem spacing (10 Ton)		6	7590000238	Marker Light - Red (LED)	
	3097000302	26' Deck - 95" wide, 8" X-mem spacing (10 Ton)		7	7493000010	Marker Light Grommet	2
	3097000314	26' Deck - 102" wide, 12" X-mem spacing (10 Ton)		8	7590000250	Marker Light - Amber (Std)	2
	3097000311	26' Deck - 102" wide, 8" X-mem spacing (10 Ton)		9	7590000242	Marker Light - Amber (LED)	
	3097000298	26' Deck - 95" wide, 8" X-mem spacing (15 Ton)		10	7330000498	Reflector - Amber	8
	3097000308	26' Deck - 102" wide, 8" x-mem spacing (15 Ton)		8	7330000497	Reflector - Red	4
	3097000304	28' Deck - 95" wide, 12" X-mem spacing (10 Ton)		9	Contact Parts	Keruing Board	A/R
	3097000301	28' Deck - 95" wide, 8" X-mem spacing (10 Ton)		10	7786000007	Screw, 0.31"-18NC x 2.00"	A/R
	3097000313	28' Deck - 102" wide, 12" X-mem spacing (10 Ton)				<i>Steel Tubular Removable Rails:</i>	
	3097000310	28' Deck - 102" wide, 8" X-mem spacing (10 Ton)		11	3729000126	Steel Rail, LH Front (24' deck)	1
				12	3729000116	Steel Rail, LH Front (26' & 28' deck)	
				13	3729000126	Steel Rail, RH Front (24' deck)	1
				14	3729000121	Steel Rail, RH Front (26' & 28' deck)	
				13	3729000121	Steel Rail, LH Mid (26' & 28' deck)	1
				14	3729000116	Steel Rail, RH Mid (26' & 28' deck)	1
				15	3729000129	Steel Rail, LH Rear (24' & 28' deck)	
				16	3729000127	Steel Rail, LH Rear (26' deck)	
				17	3729000130	Steel Rail, RH Rear (24' & 28' deck)	
				17	3729000128	Steel Rail, RH Rear (26' deck)	
					7120000005	Capscrew, 0.50"-13NC x 2.50" (24' deck)	12
					7120000005	Capscrew, 0.50"-13NC x 2.50" (26' & 28' deck)	14
				18	7701000033	End Cap (24' deck)	4
					7701000033	End Cap (26' & 28' deck)	6

# DECK - STEEL TRANSPORTER (\_10TRB & \_15TRB)

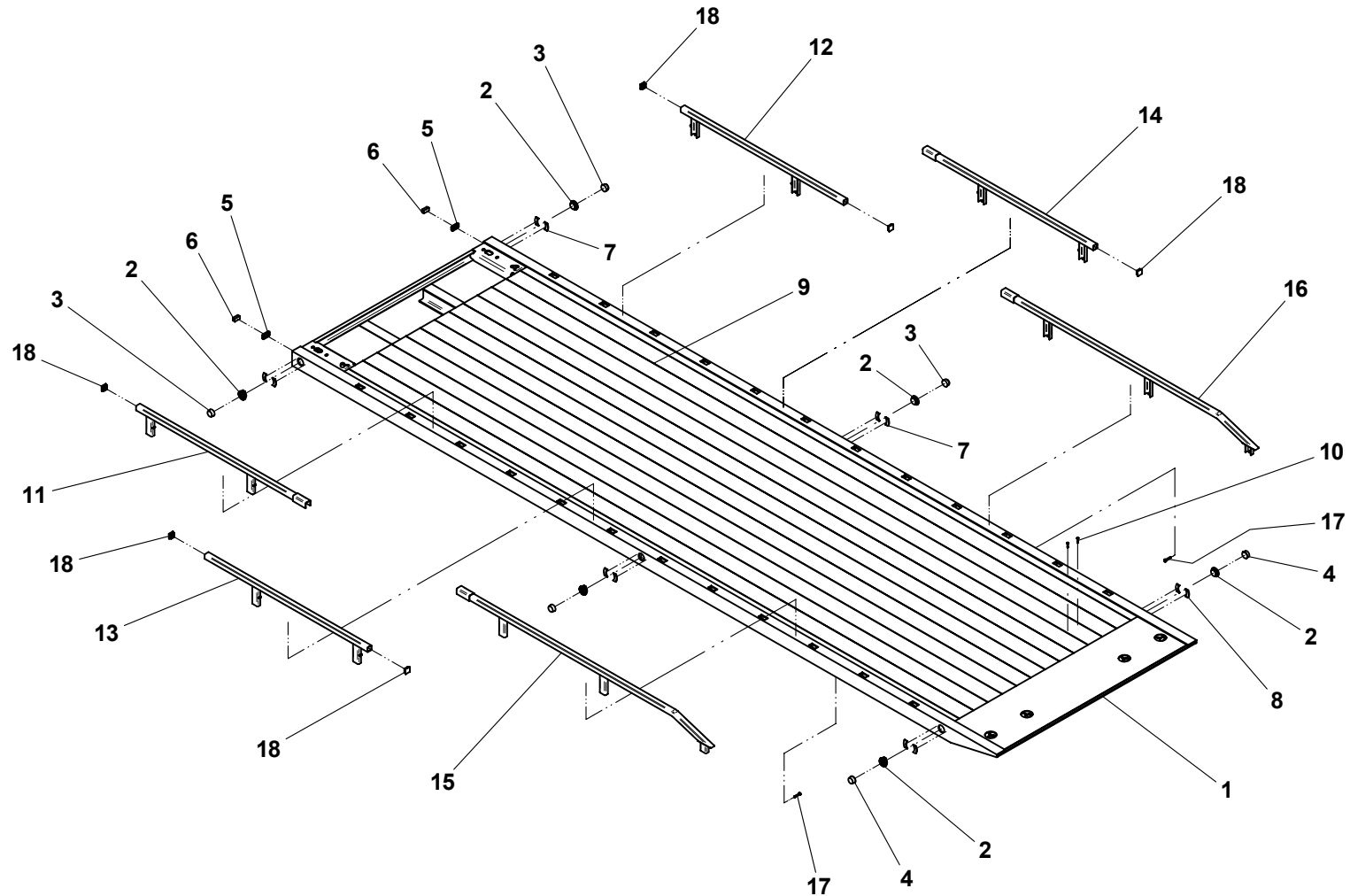

28' deck shown with removable steel rails

**DELUXE HEADBOARD**

ITEM	PART NO.	DESCRIPTION	QTY
1	3241000144	Standard Headboard Weld - 40.50"	1
	3241000145	Standard Headboard Weld - 45.50"	
	3241000146	Standard Headboard Weld - 50.50"	
	3241000147	Standard Headboard Weld - 57.50"	
2	4796000037	Gasket	2
3	7105201650	Capscrew, 0.63"-18NF x 2.00"	4
4	7950200152	Flatwasher, 0.63" ID	4
5	7660200035	Nut, 0.63"-18NF	2
6	3391000014	Screen Weld (40.50" & 45.50" headboards)	1
	3391000017	Screen Weld (50.50" headboard)	
	3391000018	Screen Weld (57.50" headboard)	
7	4796000003	Gasket	1
8	7759000015	Rivet	6



# DELUXE HEADBOARD

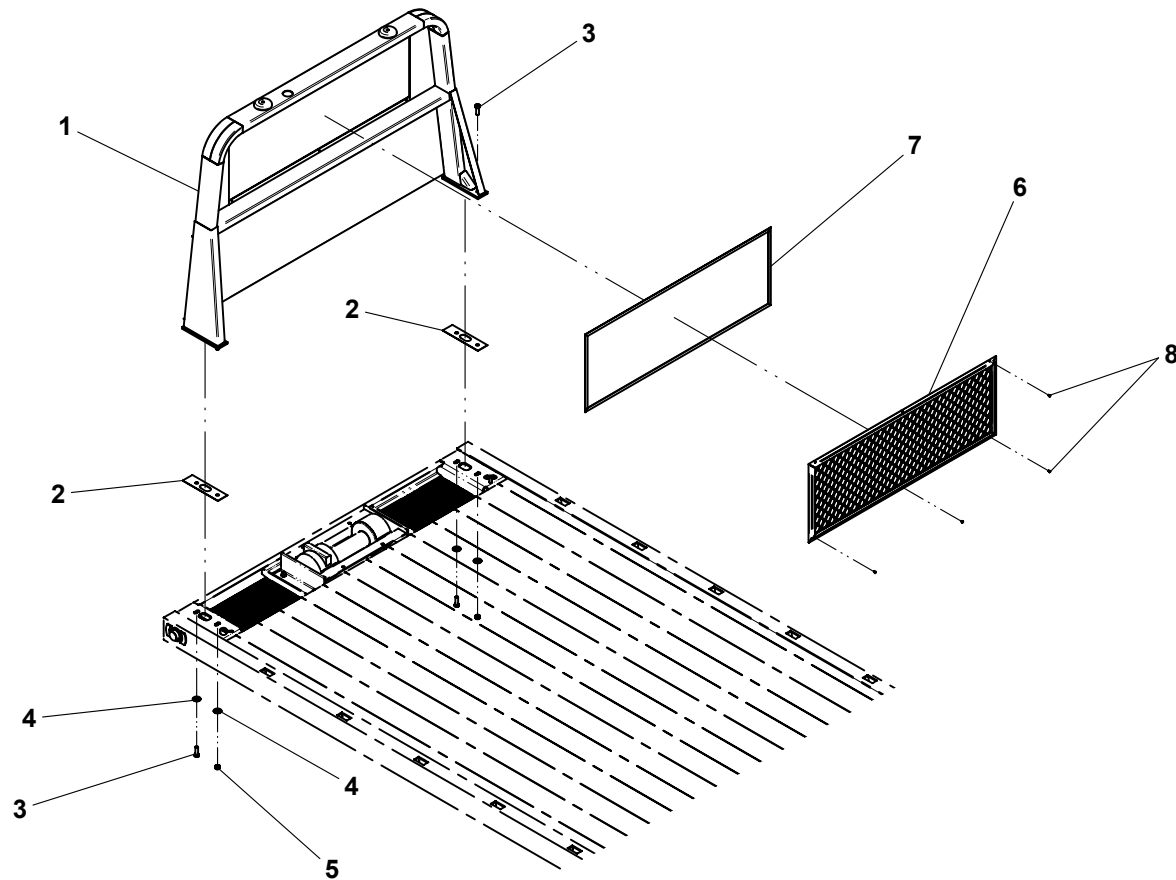

50.50" headboard shown with 12,000 lb worm gear winch

**STATIONARY HEADBOARD**

ITEM	PART NO.	DESCRIPTION	QTY
1	3241000161	Stationary Headboard Weld - 57.00"	1
	3241000162	Stationary Headboard Weld - 62.00"	
	3241000163	Stationary Headboard Weld - 69.00"	
2	7105181450	Capscrew, 0.50"-20NF x 1.75"	8
3	7950180153	Flatwasher, 0.50" ID	8
4	7660182631	Locknut, 0.50"-20NF	8
5	3391000014	Screen Weld (57.00" headboard)	1
	3391000017	Screen Weld (62.00" headboard)	
	3391000018	Screen Weld (69.00" headboard)	
6	4796000003	Gasket	1
7	7759000015	Rivet	6
8	4705000607	Shim - 0.25"	A/R
9	4705000608	Shim - 0.12"	A/R

# STATIONARY HEADBOARD

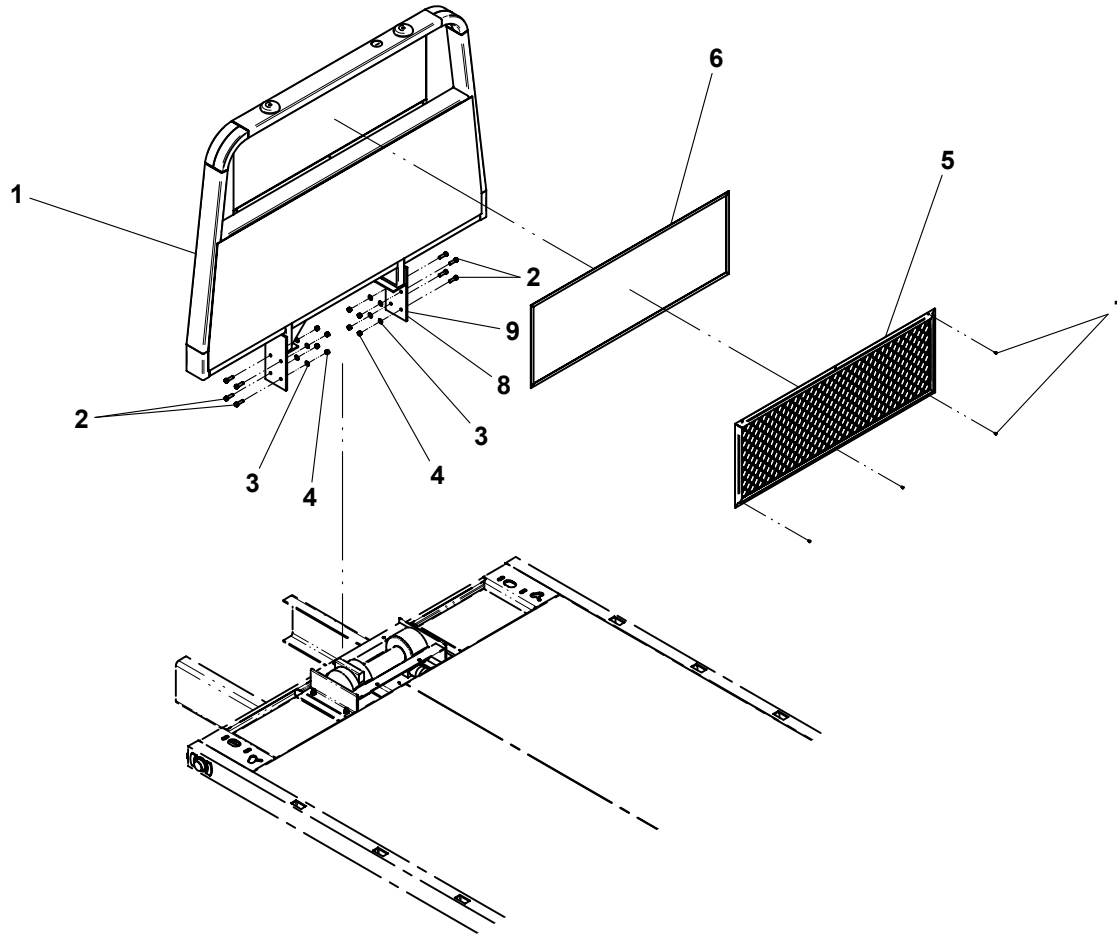

62.00" headboard shown with 12,000 lb worm gear winch

**WHEEL WELL COVERS**

ITEM	PART NO.	DESCRIPTION	QTY
1	3314000030	Cover Weld LH (96" wide deck)	1
	3314000034	Cover Weld LH (102" wide deck)	
2	3314000031	Cover Weld RH (96" wide deck)	1
	3314000035	Cover Weld RH (102" wide deck)	
3	3661000001	Wing Nut Weld	2
4	7950180252	Flatwasher, 0.50" ID	2
5	4120000019	J Bolt, 0.50"-13NC	2

# WHEEL WELL COVERS

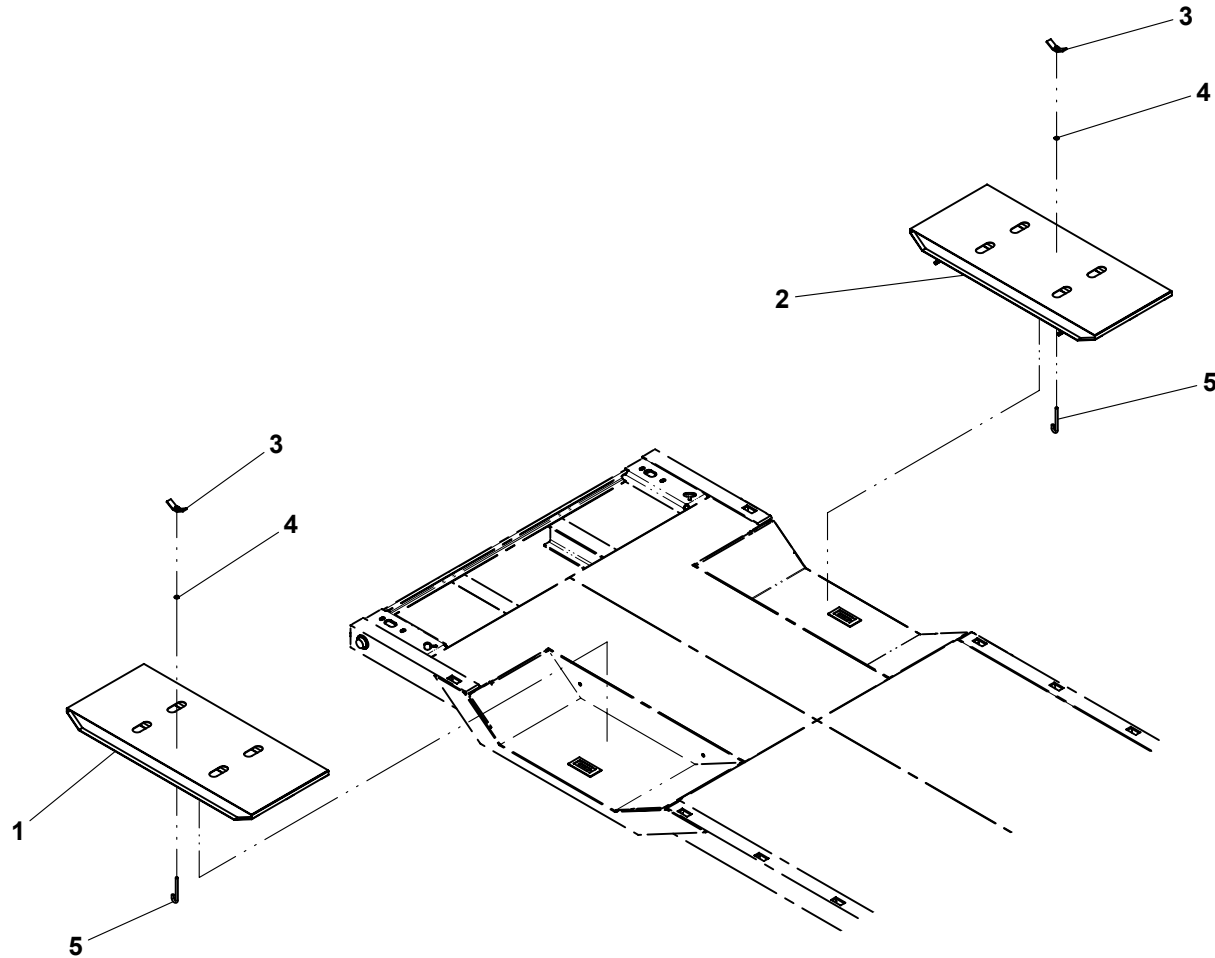

28' deck with wheel wells shown

**WINCH FREE SPOOL (12,000 LB WORM GEAR WINCH)**

ITEM	PART NO.	DESCRIPTION	QTY
1	302000091	Arm Lever weld	1
2	7785150500	Set Screw, 0.31"-18NC x .31"	1
3	7950180143	Flatwasher, 0.50" ID	2
4	4017001194	Angle	1
5	7115150850	Capscrew, 0.31"-18NC x 1.00"	1
6	7950150161	Flatwasher, 0.31" ID	2
7	7660152601	Locknut, 0.31"-18NC	3
8	7843000007	Extension Spring	1
9	7111141407	Capscrew, 0.25"-20NC x 1.75"	1
10	7950140141	Flatwasher, 0.25" ID	1
11	7660142601	Locknut, 0.25"-20NC	1
12	7990000011	Yoke	1
13	7691000046	Clevis Pin	1
14	7660180234	Jam Nut 0.50"-20NF	1
15	4209000212	Bushing	1
16	4763000253	Rod	1
17	7254000016	Cap	1
18	7690051274	Pin	1
19	7115151250	Capscrew, 0.31"-18NC x 1.50"	2
20	4178000673	Bracket	1
21	4679000208	Pad	1
22	4632000030	Trim Loc	1

# WINCH FREE SPOOL (12,000 LB WORM GEAR WINCH)

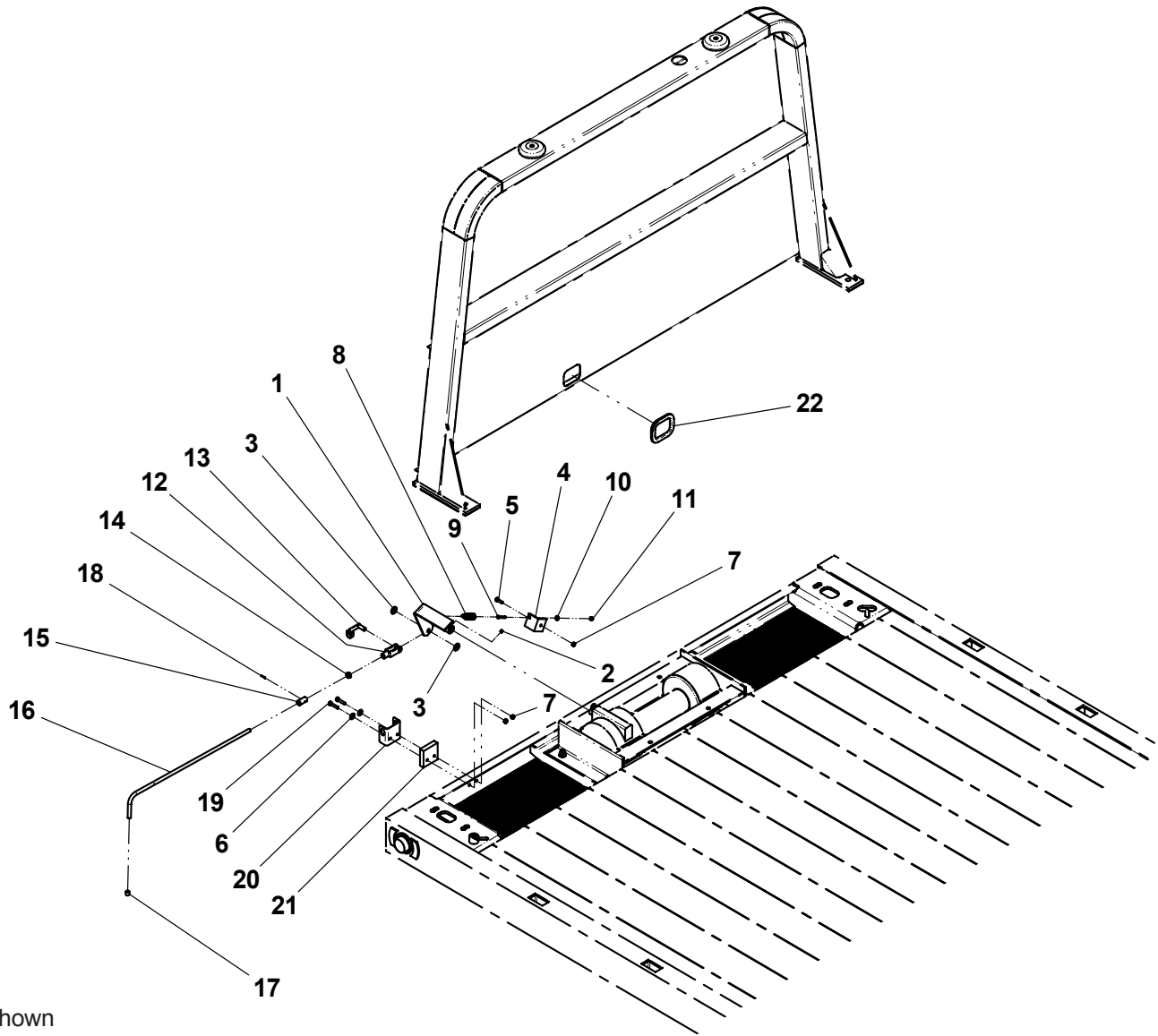

50.50" headboard shown

**WORM GEAR WINCH (12,000 LB)**

ITEM	PART NO.	DESCRIPTION	QTY
1	7970000083	Winch -12,000 lb Worm Gear	1
2	7626000018	Orbit Motor	1
3	7115181250	Capscrew, 0.50"-13NC x 1.50"	2
4	7950180400	Lockwasher, 0.50" ID	2
5	7115181464	Carriage Bolt, 0.50"-13NC x 1.75"	4
6	7950180153	Flatwasher, 0.50" ID	4
7	7660182301	Locknut, 0.50"-13NC	4
8	7248000064	Cable, 0.44" dia x 56'	1

Refer to manufacturer's manual for winch parts list



# WORM GEAR WINCH (12,000 LB)

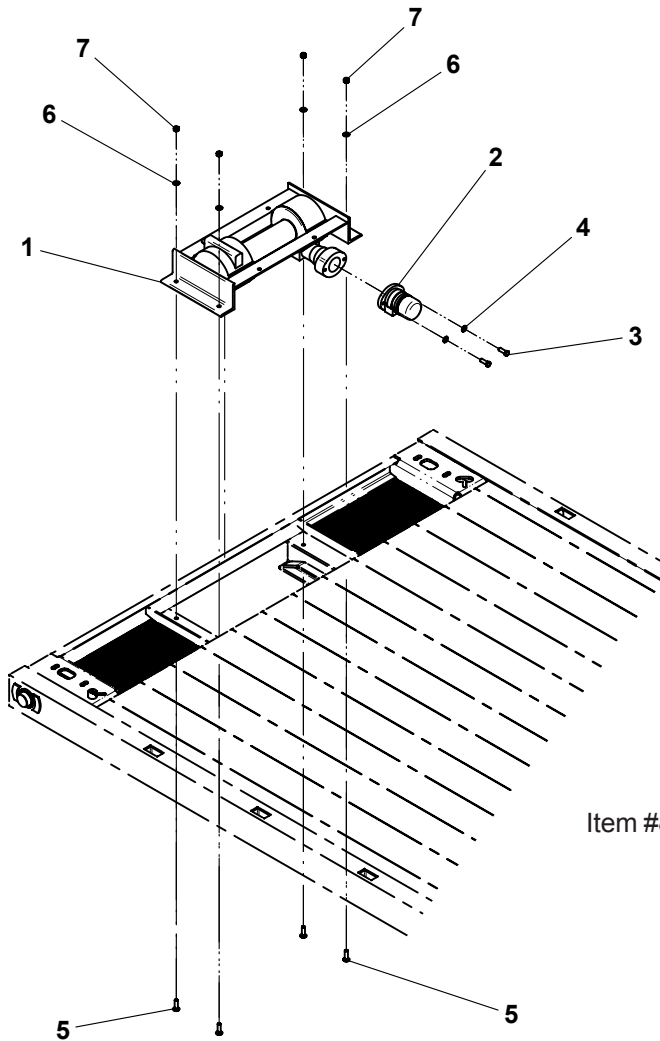

Item #8, Winch Cable, not shown

12,000 lb winch shown on transporter deck

**WORM GEAR WINCH (20,000 LB) WITH AIR FREE SPOOL**

ITEM	PART NO.	DESCRIPTION	QTY
1	797000109	Winch - 20,000 lb Worm Gear	1
2	762600011	Orbit Motor	1
3	7115181250	Capscrew, 0.50"-13NC x 1.50"	2
4	7950180400	Lockwasher, 0.50" ID	2
5	4706003273	Spacer Plate	2
6	7248000067	Cable, 0.63" dia x 75' (20,000 lb winch)	1
		<i>Air Free Spool:</i>	
7	7935000182	Air Valve	1
8	7565000014	Nylon Tubing	A/R
9	7443000364	Fitting	2
10	7640000002	Exhaust Muffler	1
11	7443000154	Bushing	1
12	7443000155	Fitting	1
13	7443000156	Nipple	2
14	7935000120	Pressure Valve	1
15	7443000152	Plug	1
16	7443000366	Fitting	1
17	7935000248	Regulator Valve	1
18	7894000004	Tie Strap	5
19	7443000365	Fitting	1
20	8597650001	Loom	A/R

Refer to manufacturer's manual for winch parts list

# WORM GEAR WINCH (20,000 LB) WITH AIR FREE SPOOL

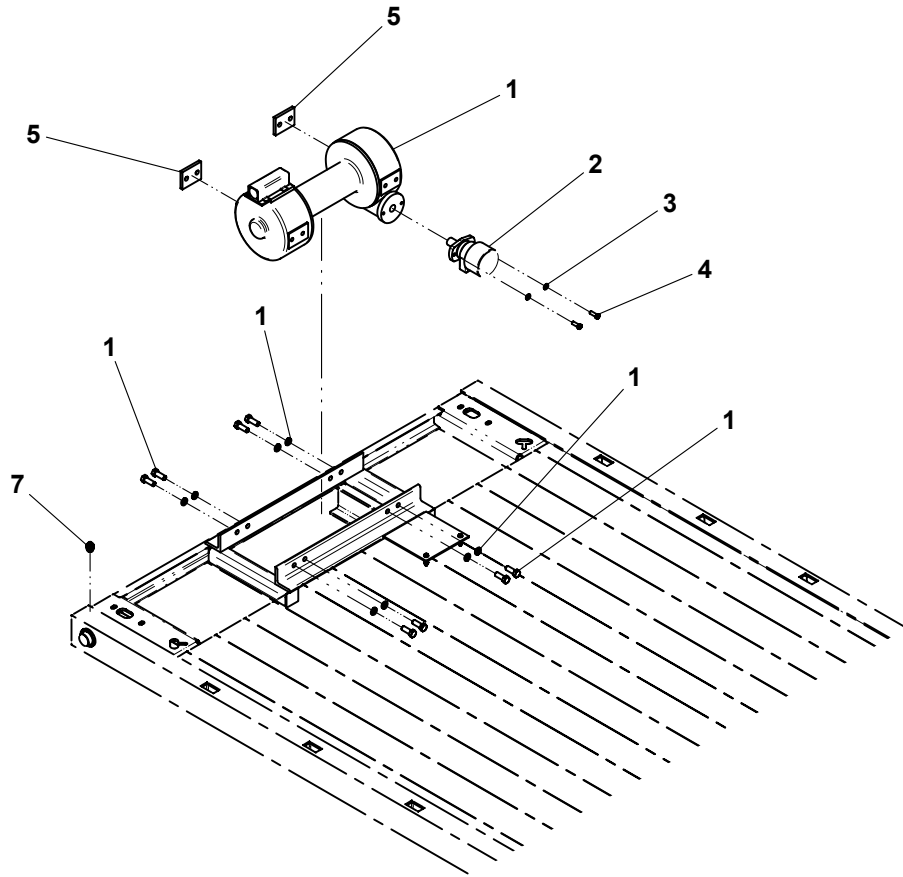

Item #6, Winch Cable, not shown

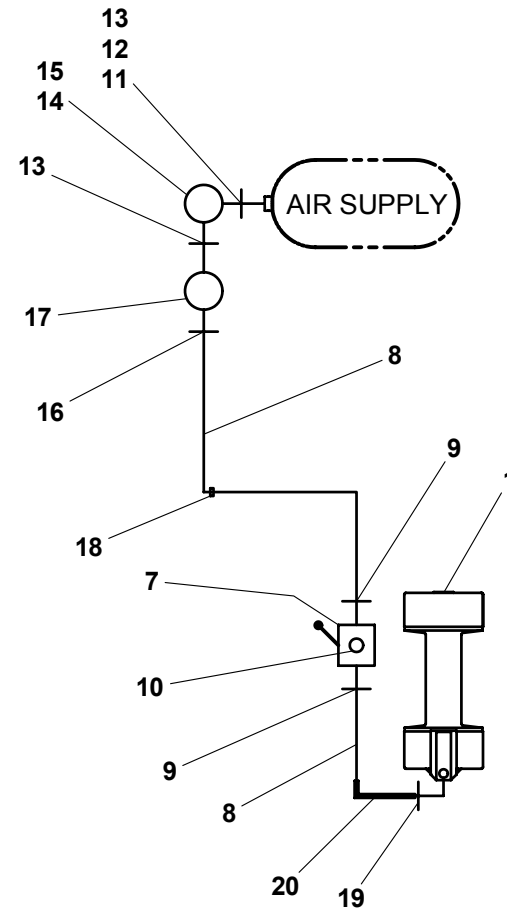

20,000 lb winch shown on transporter deck

**WORM GEAR WINCH (12,000 LB) CABLE ROLLER GUIDE / TENSIONER PLATE**

ITEM	PART NO.	DESCRIPTION	QTY
1	3178000433*	Bracket Weld	1
2	7115181464	Carriage Bolt, 0.50"-13NC x 1.75"	4
3	7950180153	Flatwasher, 0.50" ID	4
4	7660182601	Locknut, 0.50"-13NC	4
5	4706003857	Plate (12,000 lb winch)	1
6	7843000035	Spring	2
7	4912000130*	Roller	1
8	4806000014*	Shaft	1
9	4912000394*	Roller	2
10	4806000011*	Shaft	2
11	7209000011*	Bushing	6
12	7949000034*	Spacer	4
13	7754000022*	Retaining Ring	6

\* also available in Cable Guide / Tensioner Assembly, P/N 3249000036

# WORM GEAR WINCH (12,000 LB) CABLE ROLLER GUIDE / TENSIONER PLATE

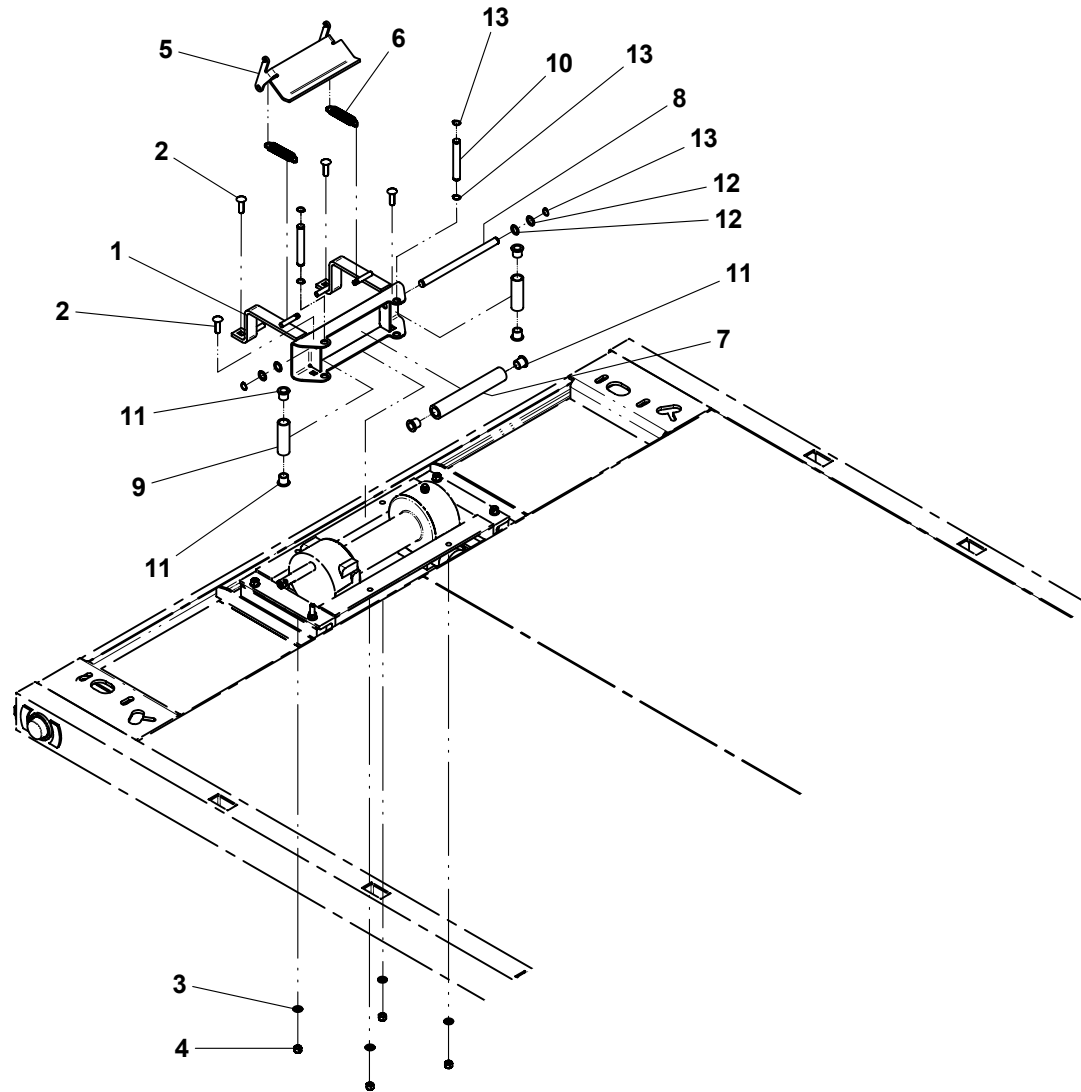

**WORM GEAR WINCH (20,000 LB) CABLE ROLLER GUIDE / TENSIONER PLATE**

ITEM	PART NO.	DESCRIPTION	QTY
1	3178000307	Bracket Weld LH	1
2	3178000308	Bracket Weld RH	1
3	3706000192	Plate Weld Pressure	1
4	7843000004	Spring	2
5	7950180161	Flatwasher, 0.50" ID	4
6	7660182600	Locknut, 0.50"-13NC	2
7	3527000075	Winch Cable Tensioner	1
8	4706001149	Plate	2
9	7950200000	Lockwasher, 0.63" ID	4
10	7111201450	Capscrew, 0.63"-11NC x 1.75"	4

# WORM GEAR WINCH (20,000 LB) CABLE ROLLER GUIDE / TENSIONER PLATE

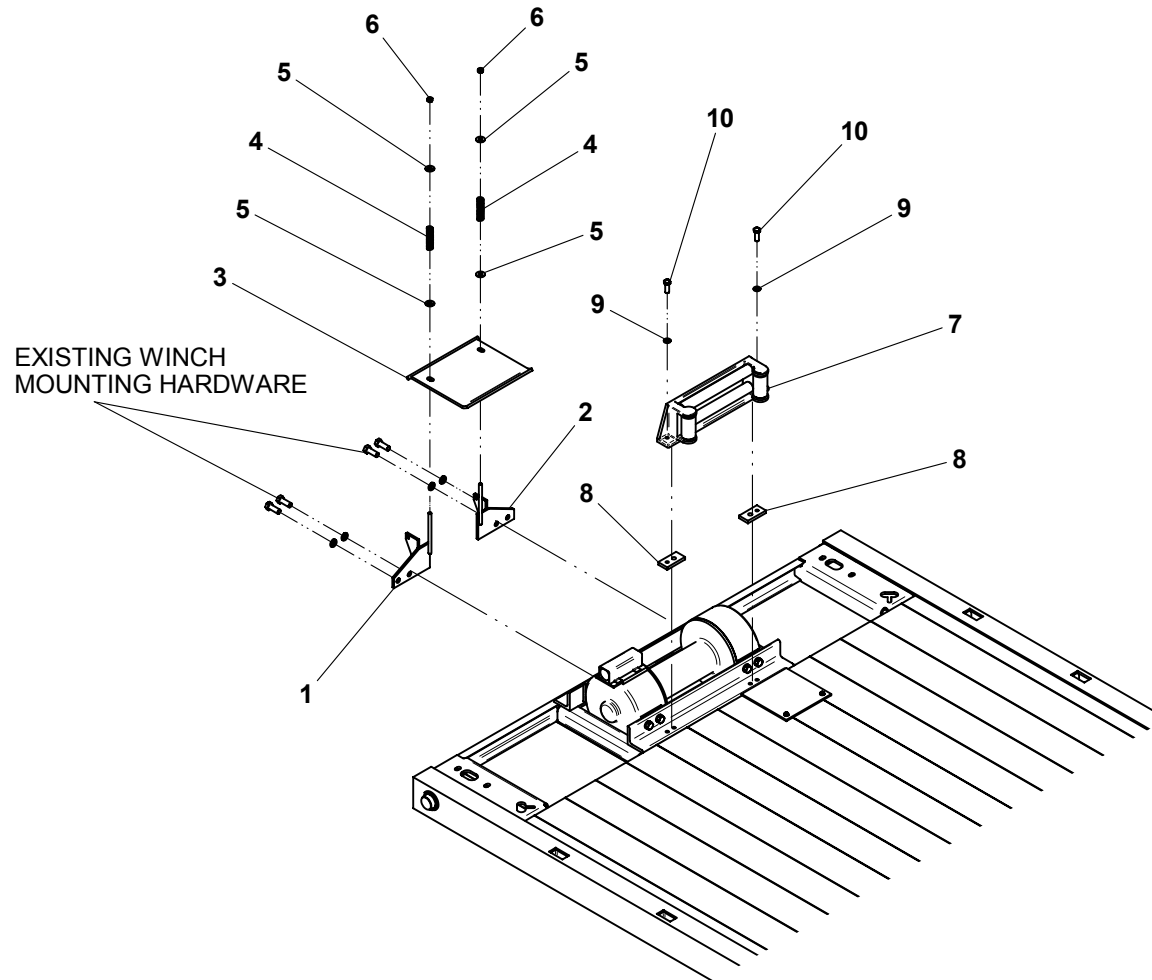

**SUBFRAME**

ITEM	PART NO.	DESCRIPTION	QTY	ITEM	PART NO.	DESCRIPTION	QTY
1	3868000266	Subframe Weld (24' & 26' decks)	1	29	3320000121	Extend Cylinder Assembly (24' & 26' decks)	1
	3868000267	Subframe Weld (28' deck)					
	3868000273	Subframe Weld (24' & 26' wide-deck)			3320000128	Extend Cylinder Assembly (28' deck)	
	3868000274	Subframe Weld (28' wide-deck)		30	4691000268	Pin	1
2	3905000010	Trunnion Weld	1	31	7754000006	Retaining Ring	2
3	4497000368	Gusset	2	32	4706003033	Plate	1
4	7082000019+	Bearing	4	33	4679000166	Pad	1
5	4691000348	Pin	2	34	4178000308	Bracket	1
6	7118162250	Capscrew, 0.38"-16NC x 2.75"	2	35	7660182601	Locknut, 0.50"-13NC	2
7	7660162601	Locknut, 0.38"-16NC	2	28	4017001293*	Mud Flap Angle, LH	1
8	3178000288	Bracket Weld LH	1	29	4017001294*	Mud Flap Angle, RH	1
9	3178000289	Bracket Weld RH	1	26	3178000233*	Light Box, LH	1
10	3320000129	Tilt Cylinder Assembly	2	27	3178000234*	Light Box, RH	1
11	3062000015	Bar Weld LH	1				
12	3062000014	Bar Weld RH	1				
13	4831000079	Spacer, 0.50"	2				
14	4831000083	Spacer, 0.25"	2				
15	4831000084	Spacer, 0.12"	2				
16	4017001093	Angle	2				
17	3691000164	Pin Weld	2				
18	3691000184	Pin Weld	2				
19	4209000204	Bushing	4				
20	7105202250	Capscrew, 0.63"-18NF x 2.75"	4				
21	7105201650	Capscrew, 0.63"-18NF x 2.00"	4				
22	7660202347	Locknut, 0.63"-18NF	8				
23	7115160850	Capscrew, 0.38"-16NC	2				
24	7660162301	Locknut, 0.38"-16" ID	4				
25	7115161050	Capscrew, 0.38"-16NC x 1.25"	2				
26	7105181450	Capscrew, 0.50"-20NF x 1.75"	4				
27	7950180153	Flatwasher, 0.50"	4				
28	7660182333	Locknut, 0.50"-20NF	4				

\* included in Subframe Welds, P/N 3868000266, 3868000267, 3868000273 & 3868000274

+included in Trunnion Weld, P/N 3905000010



# SUBFRAME

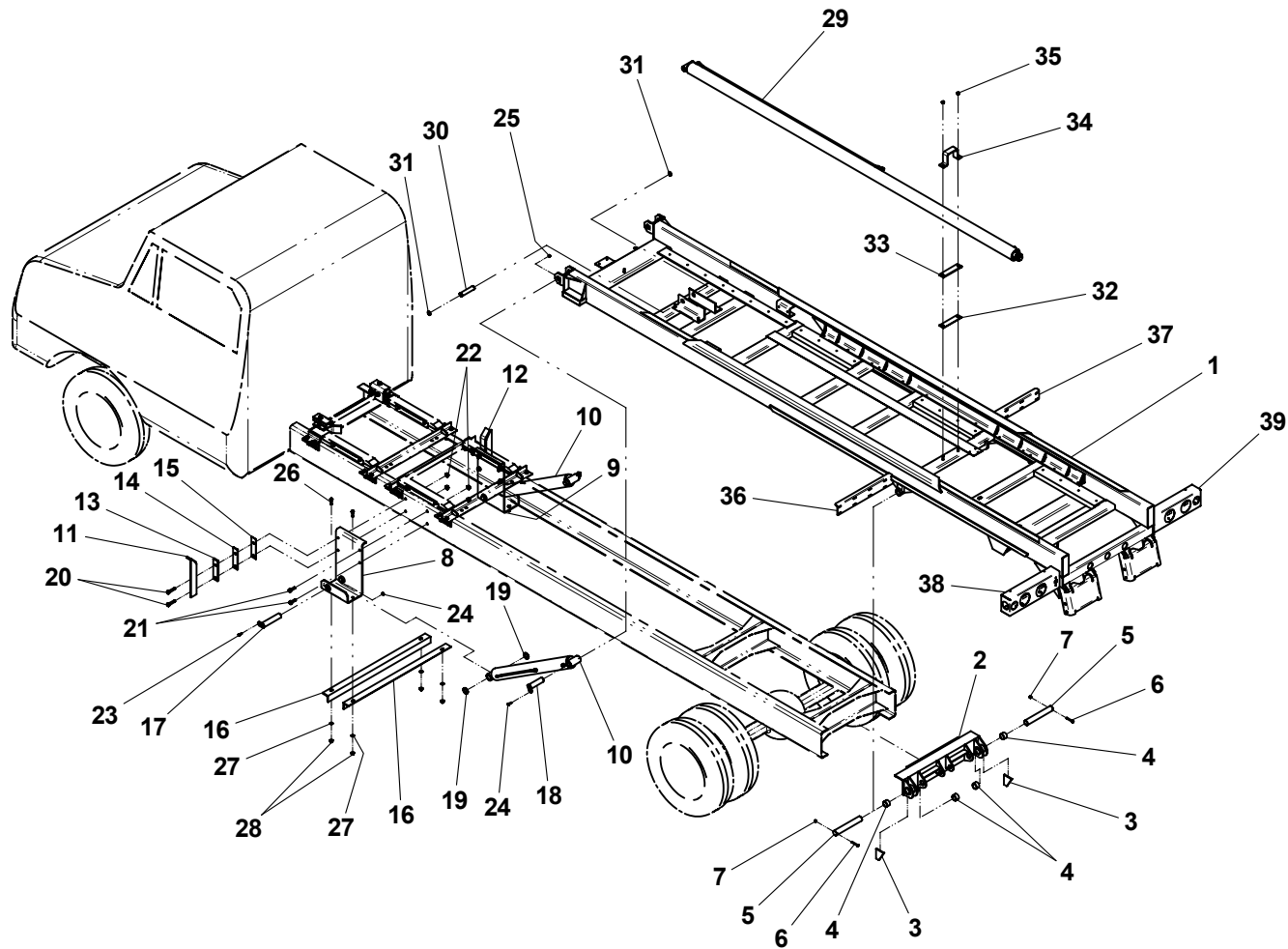

Subframe for 26' & 28' Deck shown

**HOLD DOWN**

ITEM	PART NO.	DESCRIPTION	QTY
1	3558000008	Hold Down Weld - Primary	1
2	4017001271	Angle (24' deck)	4
	4017001271	Angle (26' & 28' decks)	8
3	7105181450	Capscrew, 0.50"-20NF x 1.75" (24' deck)	14
	7105181450	Capscrew, 0.50"-20NF x 1.75" (26' & 28' decks)	26
4	7660182333	Locknut, 0.50"-20NF (24' deck)	8
	7660182333	Locknut, 0.50"-20NF (26' & 28' decks)	16
5	7950180153	Flatwasher, 0.50 ID (24' deck)	12
	7950180153	Flatwasher, 0.50 ID (26' & 28' decks)	20
6	7660182631	Locknut, 0.50"-20NF (24' deck)	6
	7660182631	Locknut, 0.50"-20NF (26' & 28' decks)	10
7	4679000194	Pad (24' deck)	2
	4679000194	Pad (26' & 28' decks)	4
8	7790152056	Screw, 0.31"-18NC x 1.25" (24' deck)	8
	7790152056	Screw, 0.31"-18NC x 1.25" (26' & 28' decks)	16
9	7105201250	Capscrew, 0.63"-18NF x 1.50"	2
10	7259000015	Hold Down Shoe LH	1
11	7259000016	Hold Down Shoe RH	1
12	4706003025	Rub Plate LH	1
13	4706003026	Rub Plate RH	1
14	4706003027	Plate (10 ton deck only)	2
15	7105202050	Capscrew, 0.63"-18NF x 2.50"	4
16	7660202347	Locknut, 063"-18NF	4
17	3558000007	Hold Down Weld - Secondary (26' & 28' decks)	1

# HOLD DOWN

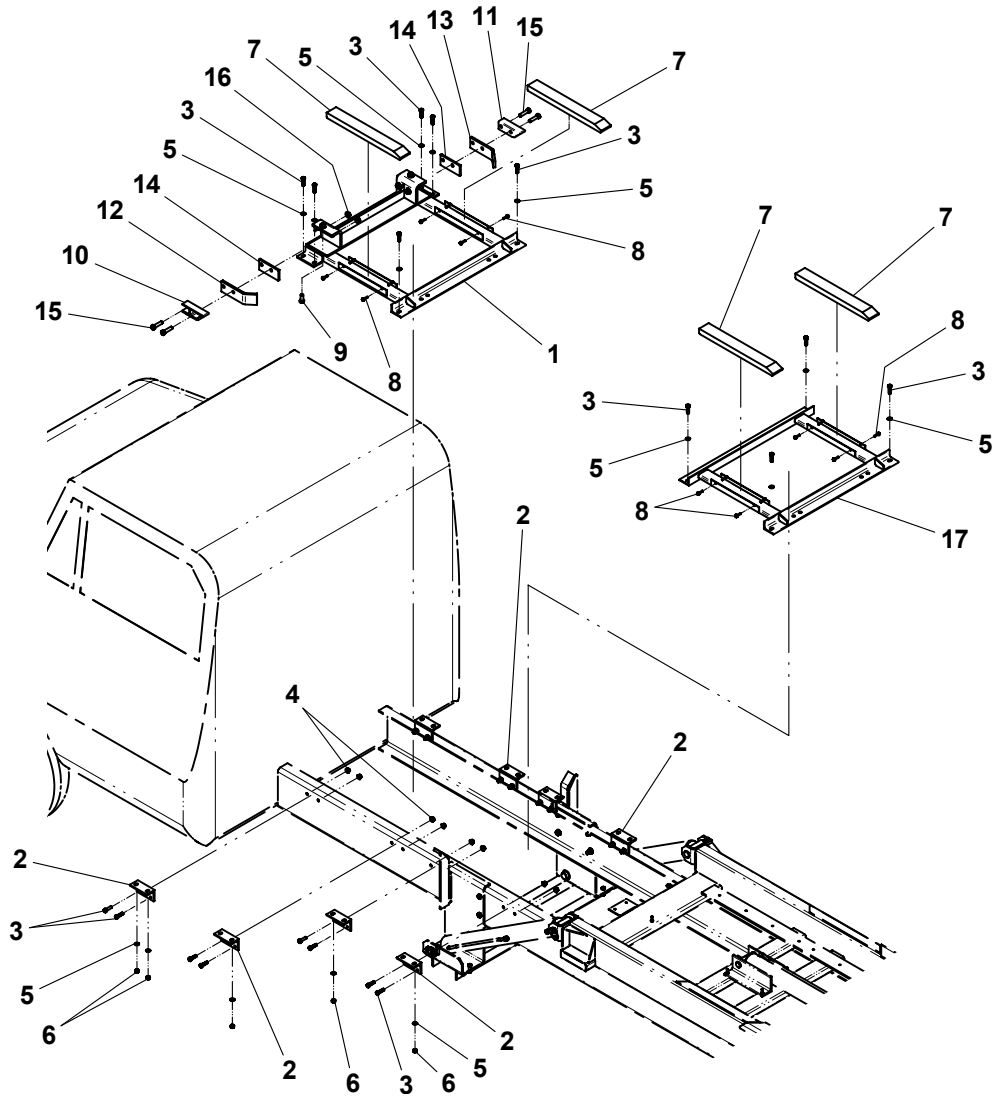

**SLIDE PAD**

ITEM	PART NO.	DESCRIPTION	QTY
1	4679000192*	Wear Pad (24' deck)	6
	4679000192^	Wear Pad (26' & 28' decks)	10
2	4679000193*^	Wear Pad	8
3	4679000154*	Wear Pad (24' deck)	2
	4679000267^	Wear Pad (26' & 28' decks)	2
4	7118161026*	Capscrew, 0.38"-16NC x 1.25" (24' deck)	52
	7118161026^	Capscrew, 0.38"-16NC x 1.25" (26' & 28' decks)	68
5	7660162601*	Locknut, 0.38"-16NC (24' deck)	52
	7660162601^	Locknut, 0.38"-16NC (26' & 28' decks)	68

\* included in Wear Pad Kit, P/N 9577000230 (24' Decks)

^ included in Wear Pad Kit, P/N 9577000229 (26' & 28' decks)

# SLIDE PAD

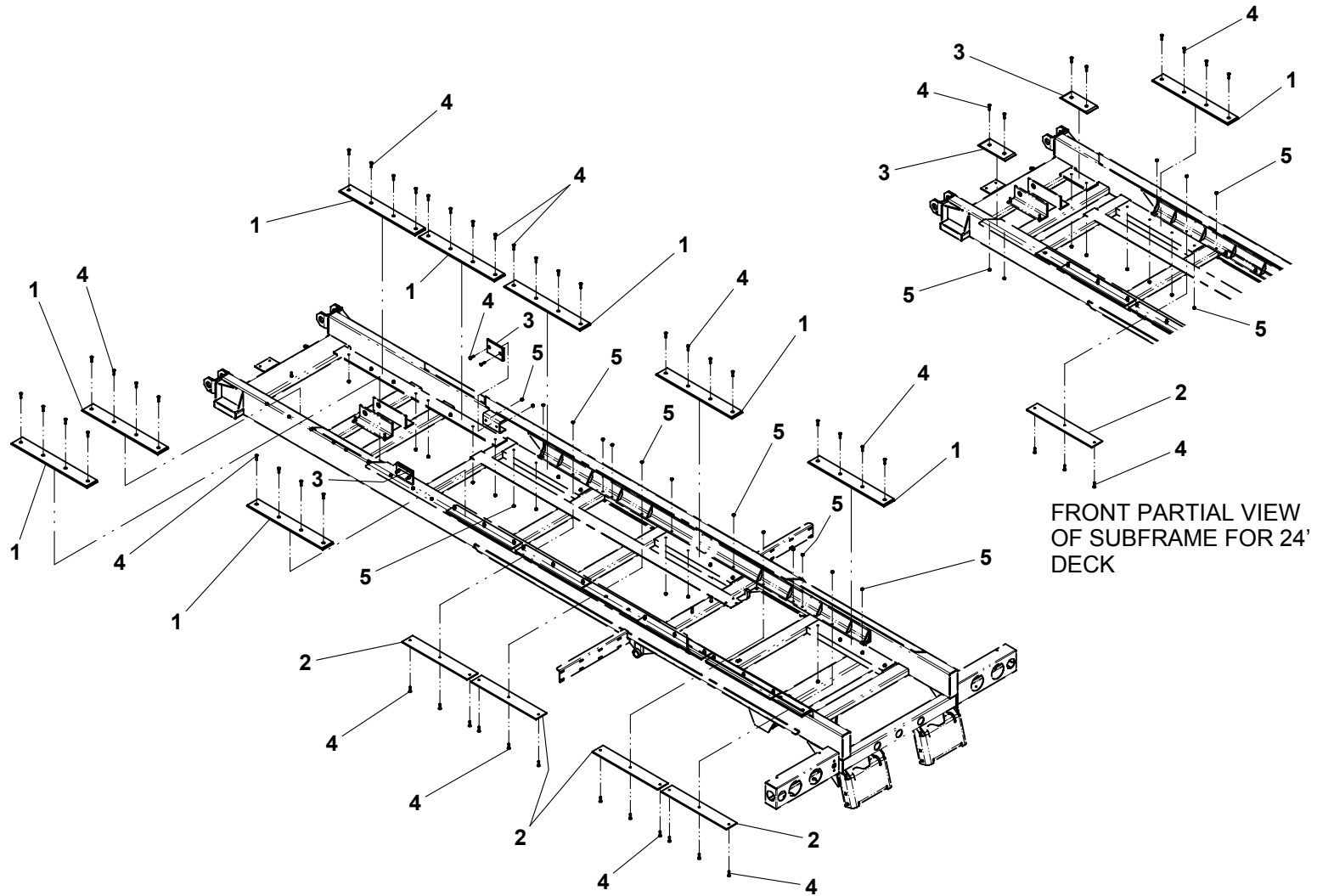

**MUD FLAP**

ITEM	PART NO.	DESCRIPTION	QTY
1	7638000004	Mud Flap - Standard, 30" long	2
	7638000013	Mud Flap - High Frame, 36" long	
2	4706000233	Plate	2
3	7111150864	Carriage Bolt, 0.31"-18NC x 1.00"	8
4	7660152601	Locknut, 0.31"-18NC	8

# MUD FLAP

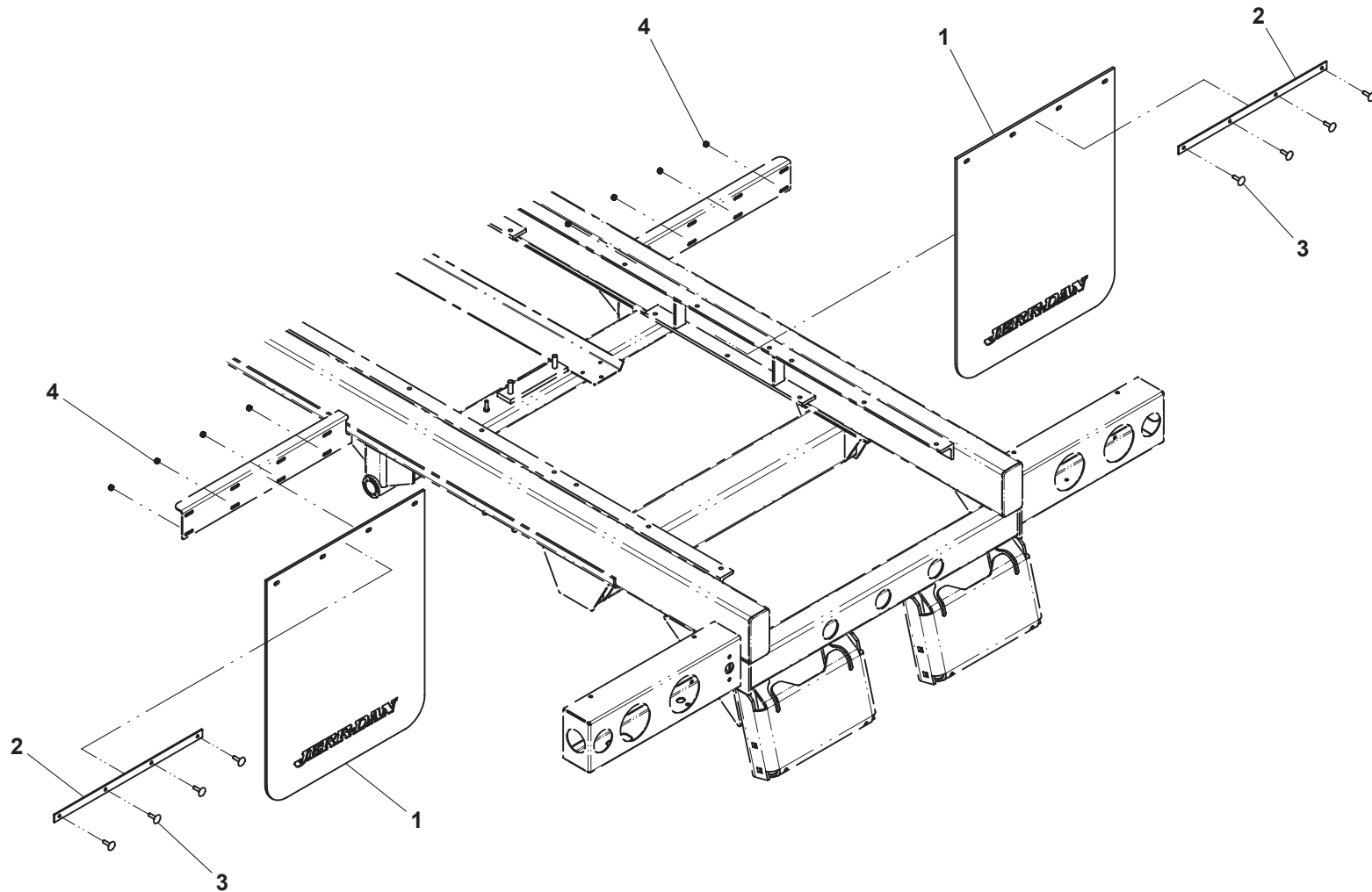

**FINAL ASSEMBLY**

ITEM	PART NO.	DESCRIPTION	QTY
1	3190000037	Bumper Tube Weld - Short	2
	3190000034	Bumper Tube Weld - Long	
2	7115181064	Carriage Bolt, 0.50"-13NC x 1.25"	8
3	7660182601	Locknut, 0.50"-13NC	8
4	4314000043	Light Box Cover	2
5	7661000042	U-Nut, 0.25"-20NC	8
6	7949000023	Nylon Washer, 0.26" ID	10
7	7114140529	Screw, 0.25"-20NC x 0.63"	8
8	7493000002	Grommet	4
9	7590000248	Back-Up Light - White (Std)	2
10	7590000247	Stop/Tail/Turn Light - Red (Std)	2
	7590000241	Stop/Tail/Turn Light - Red (LED)	
11	7493000009	Grommet	4
12	7590000245	Marker Light - Red (Std)	4
	7590000238	Marker Light - Red (LED)	
13	7493000023	Grommet	3
14	7590000246	Marker Light - Red (Std)	3
	7590000240	Marker Light - Red (LED)	
15	7493000010	Grommet	1
16	7590000251	License Plate Light	1
17	7011000007	Back-Up Alarm	1
18	7114140528	Screw, 0.25"-20NC x 0.63"	2
19	7660142601	Locknut, 0.25-20NC	2
20	7701000049	Plug	1
21	7701000055	Plug	2
22	7330000497	Reflector - Red	8
23	7330000428	Reflective Tape	2
24	4314000086	Cover Plate	2
25	7790161253	Screw, 0.38"-16NC x 0.75"	8
26	7679000020	Non-Skid Pad	2



# FINAL ASSEMBLY

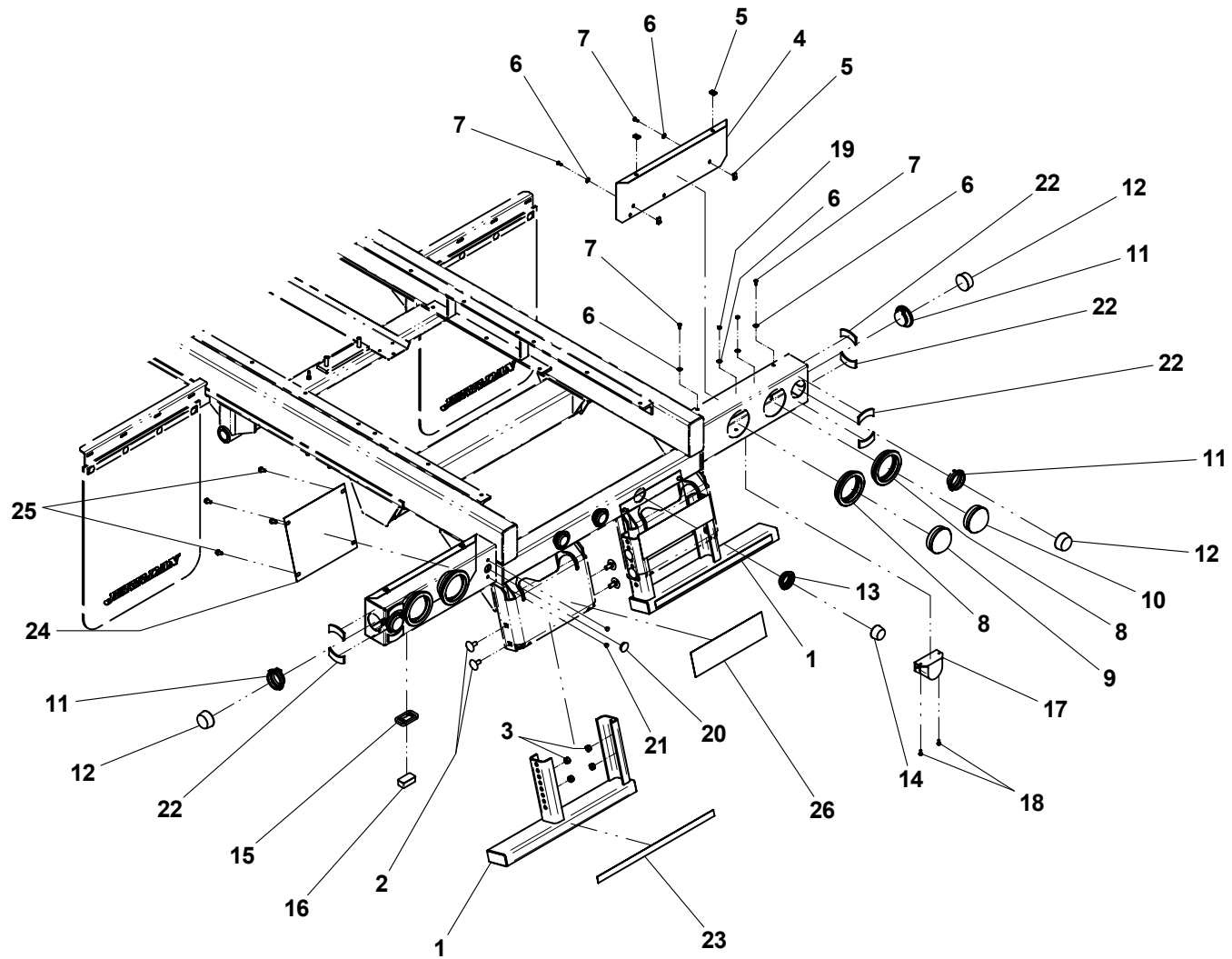

**HYDRAULIC RESERVOIR AND TOOLBOX / BASKET**

ITEM	PART NO.	DESCRIPTION	QTY*
1	4178000331	Mounting Bracket - Short	
	4178000291	Mounting Bracket - Std	
	4178000339	Mounting Bracket - Long	
2	4178000330	Mounting Bracket - Short	
	4178000290	Mounting Bracket - Std	
	4178000338	Mounting Bracket - Long	
3	3750000018	Hydraulic Reservoir Assembly	
4	7183000004+	Breather Filler Cap Assembly	
5	7470000009+	Level / Temperature Gauge	
6	7430000014+	Strainer	
7	7105181450	Capscrew, 0.50"-20NF x 1.75"	
8	7950180153	Flat Washer, 0.50" ID	
9	7660182631	Locknut, 0.50"-20NF	
10	7115150850	Capscrew, 0.31"-18NC x 1.00"	
11	7950150161	Flatwasher, 0.31" ID	
12	7660152601	Locknut, 0.31"-18NC	
13	3899000130	Toolbox Assembly - 36" x 18" x 18"	
	3899000131	Toolbox Assembly - 36" x 18" x 14"	
	3899000132	Toolbox Assembly - 48" x 18" x 18"	
	3899000133	Toolbox Assembly - 60" x 18" x 18"	
14	4679000256^	Rubber Pad (36" Toolbox)	
	4679000257^	Rubber Pad (48" Toolbox)	
	4679000258^	Rubber Pad (60" Toolbox)	
15	7118181216	Capscrew, 0.50"-13NC x 1.50"	
16	7660182301	Locknut, 0.50"-13NC	
17	4706002361	Plate	
18	4017000777	High Mount Angle	
19	3899000053	Basket - 15" deep	
	3899000075	Basket - 24" deep	
20	4632000015	Moulding - 15" deep basket	
	4632000048	Moulding - 24" deep basket	
21	7002000410	Stainless Steel Cover Plate for Basket includes rivets	

+ also available in Hydraulic Reservoir Assembly, P/N 3750000018

^ included in Toolbox Assembly

\* Quantities vary depending on Hydraulic Tank / Toolbox / Basket mounting configuration.

# HYDRAULIC RESERVOIR AND TOOLBOX / BASKET

HYDRAULIC TANK ONLY

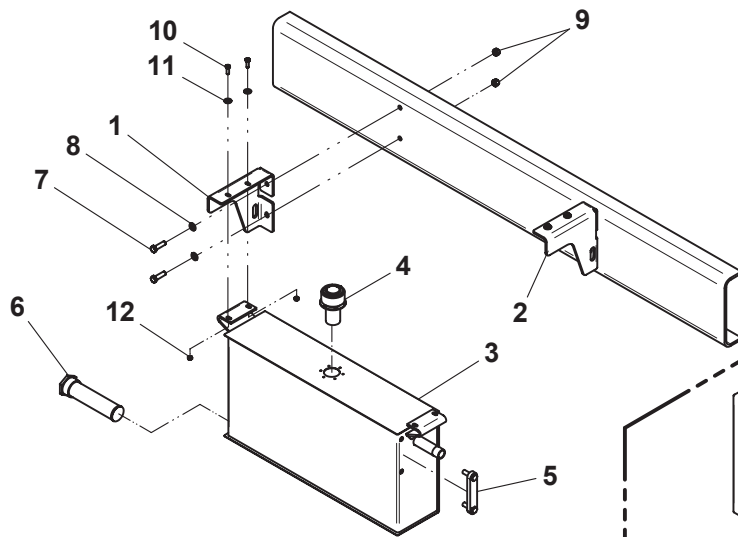

36" TOOLBOX  
w/ HYDRAULIC RESERVOIR

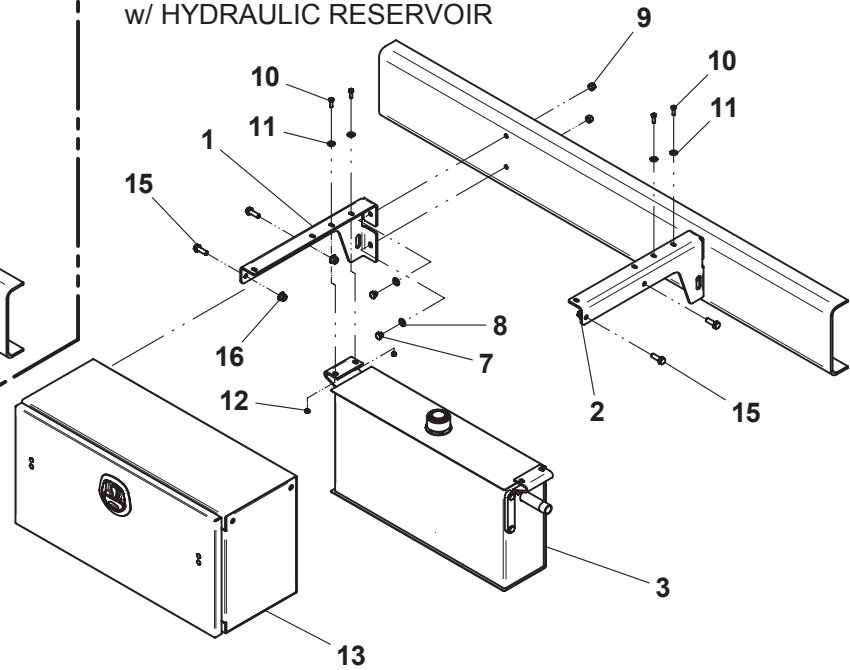

Item #14, Toolbox Rubber Pad, not shown

### HYDRAULIC RESERVOIR AND TOOLBOX / BASKET

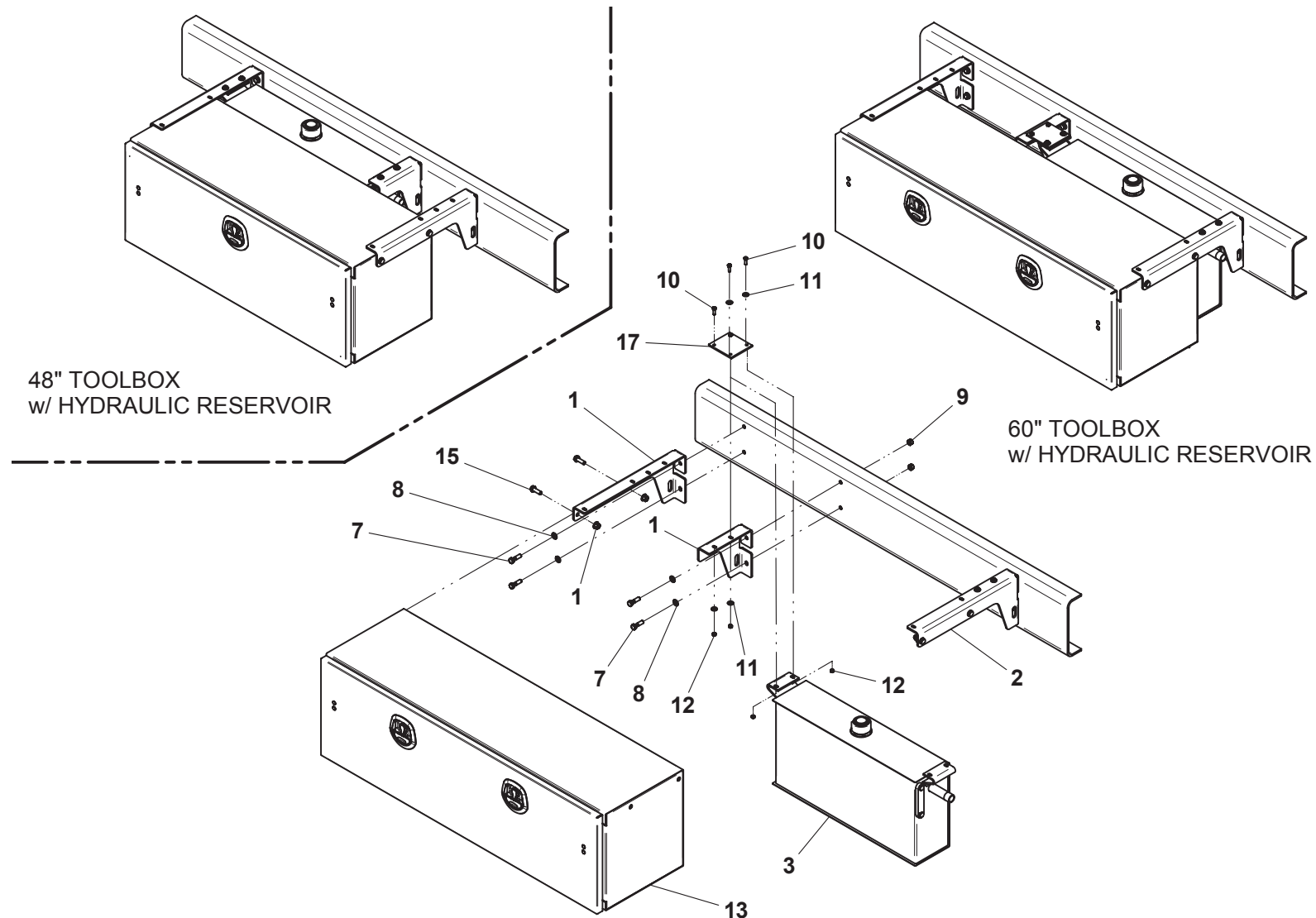

48" TOOLBOX  
w/ HYDRAULIC RESERVOIR

60" TOOLBOX  
w/ HYDRAULIC RESERVOIR

Item #14, Toolbox Rubber Pad, not shown

# HYDRAULIC RESERVOIR AND TOOLBOX / BASKET

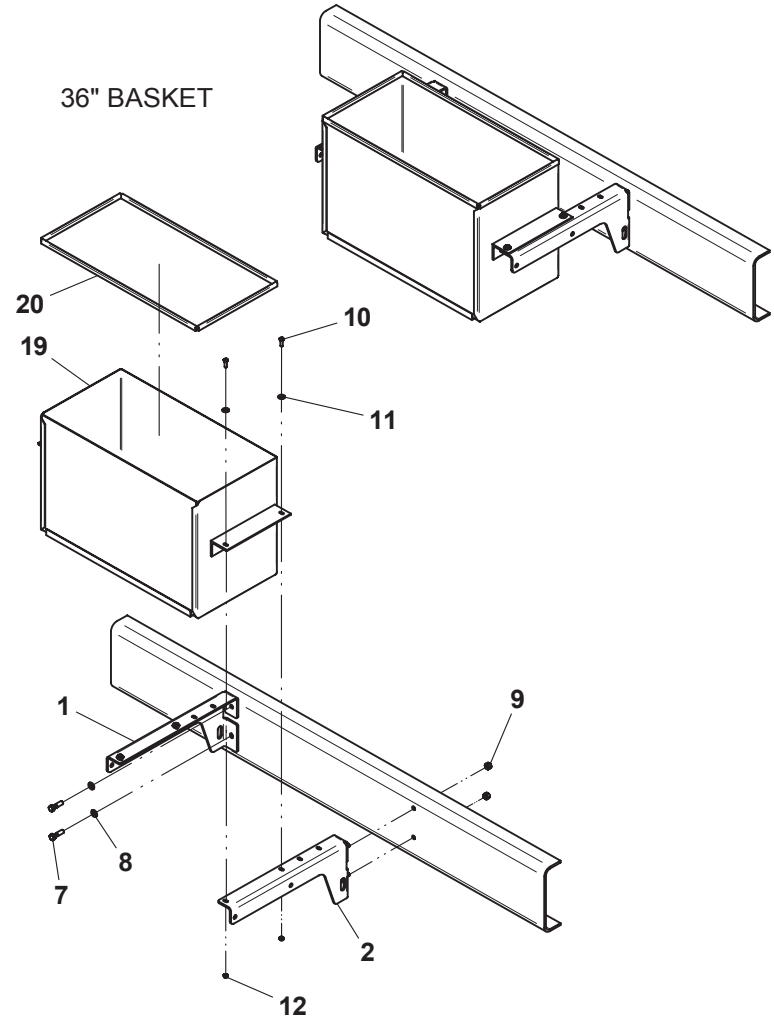
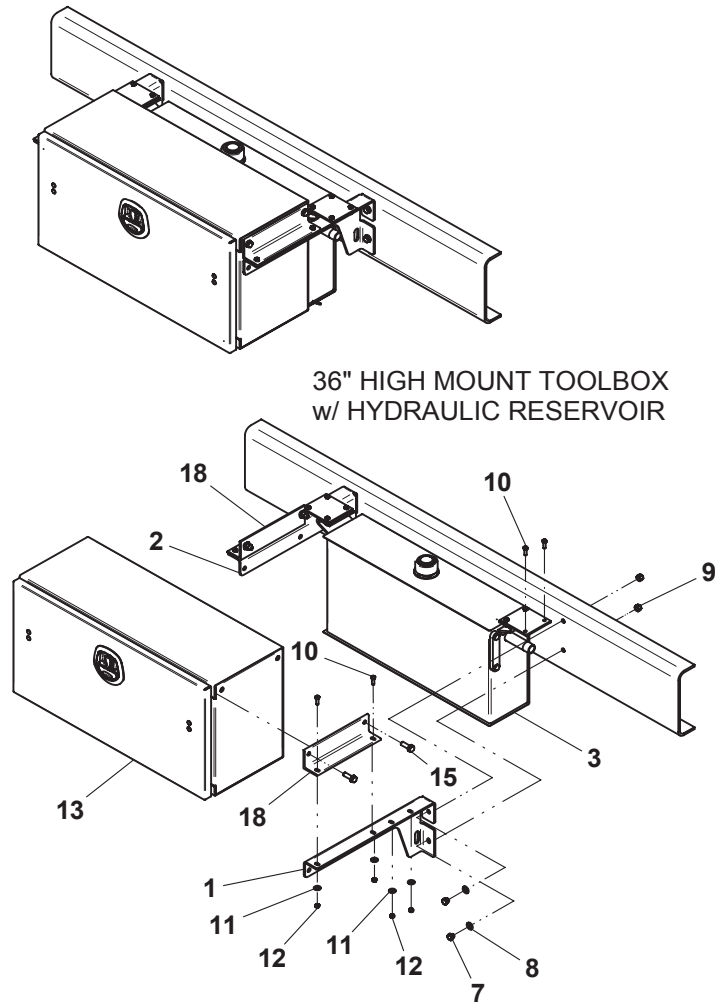

Items #14, Toolbox Rubber Pad and #21, Stainless Cover for Basket, not shown

**TOOLBOX**

ITEM	PART NO.	DESCRIPTION	QTY*
1	4679000256	Rubber Pad (36" toolbox)	1
	4679000257	Rubber Pad (36" narrow toolbox)	1
	4679000258	Rubber Pad (48" toolbox)	1
	4679000259	Rubber Pad (60" toolbox)	1
2	4796000009	Gasket (36" toolbox)	1
	4796000010	Gasket (48" toolbox)	1
	4796000011	Gasket (60" toolbox)	1
3	9899000014	Toolbox Door Assembly (36" toolbox)	1
	9899000015	Toolbox Door Assembly (48" toolbox)	1
	9899000016	Toolbox Door Assembly (60" toolbox)	1
4	7585000019^	Latch	1
5	7555000016^	Hinge (36" toolbox)	1
	7555000015^	Hinge (48" toolbox)	2
	7555000016^	Hinge (60" toolbox)	2
6	7759000020^	Rivet (36" toolbox)	9
	7759000020^	Rivet (48" toolbox)	14
	7759000020^	Rivet (60" toolbox)	18
7	4178000599^	Bracket	2
8	7114140465^	Carriage Bolt, 0.25"-20NC x 0.50"	4
9	7660142604^	Locknut, 0.25" -20NC	4
10	7592000005^	S Link	4
11	7248000114^	Cable	2

\* Quantities listed are for one toolbox

^ also included in Toolbox Door Assembly

# TOOLBOX

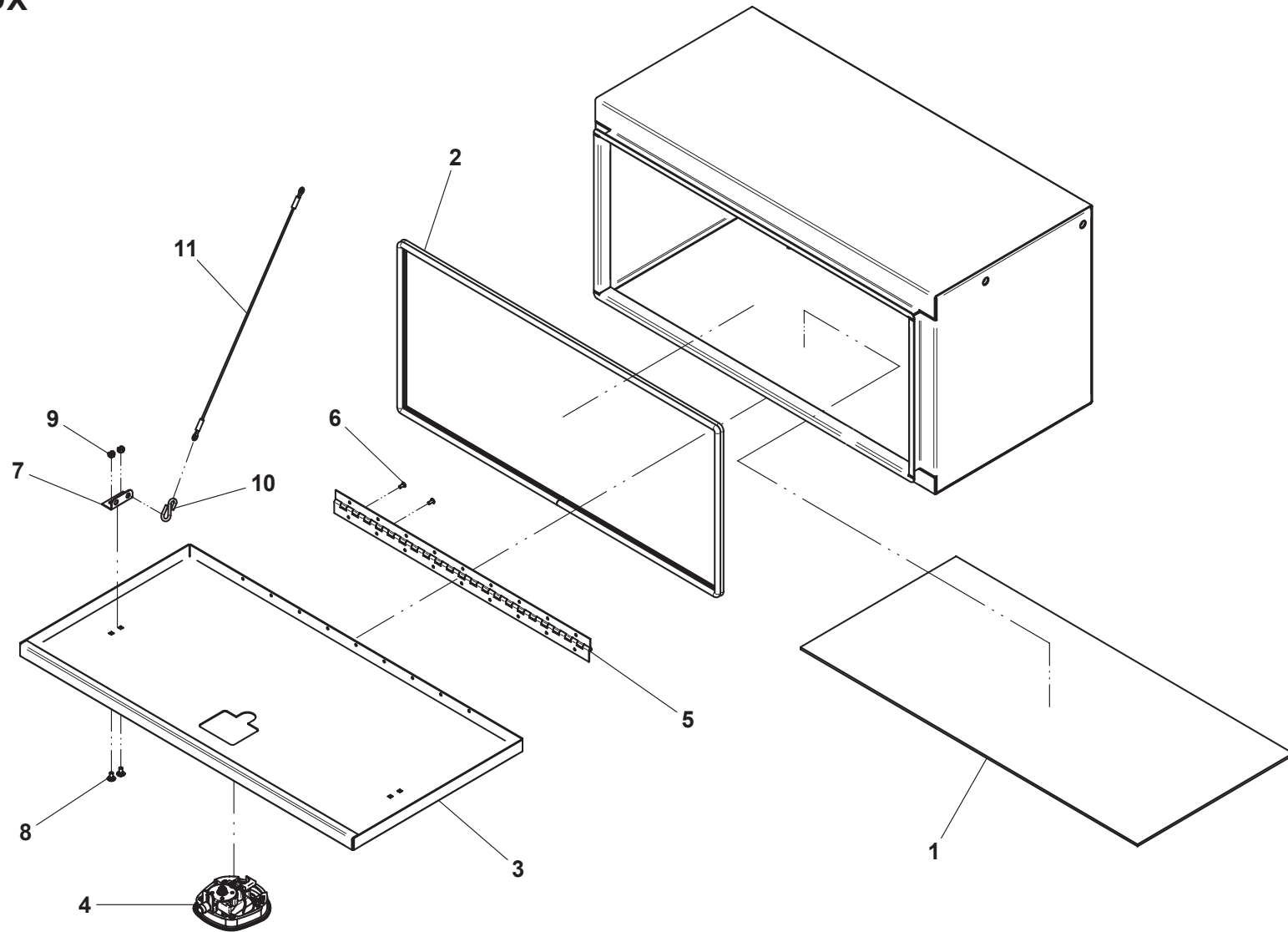

36" Toolbox shown

**TOOLBOX SHELF**

ITEM	PART NO.	DESCRIPTION	QTY
1	4017001403	Angle	2
2	4811000841	Shelf (36" toolbox)	1
	4811000843	Shelf (48" toolbox)	
	4811000868	Shelf (60" toolbox)	
3	7115150850	Capscrew, 0.31"-18NC x 1.00"	4
4	7950150161	Flatwasher, 0.31" ID	8
5	7660152601	Locknut, 0.31"-18NC	4



## TOOLBOX SHELF

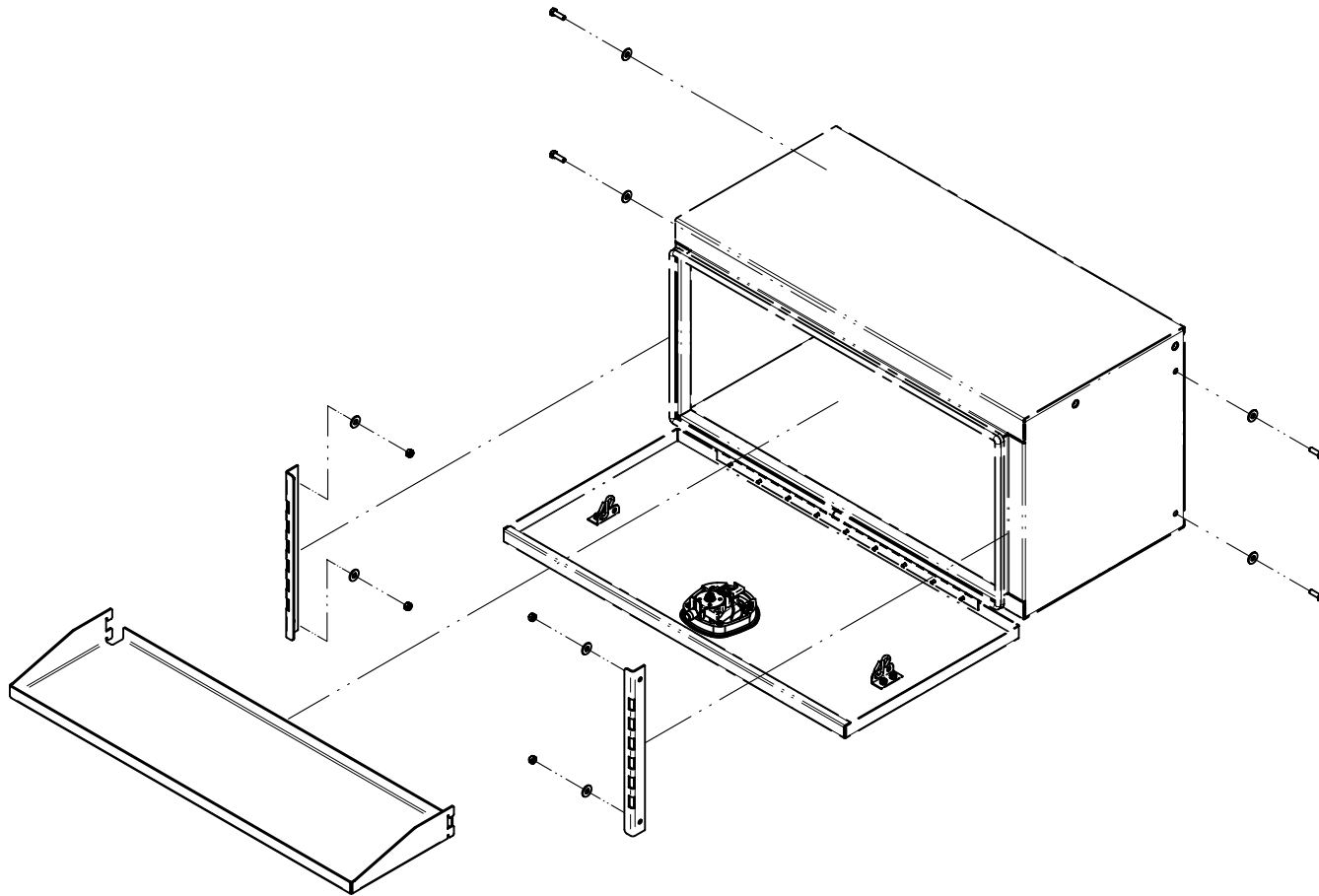

36" Toolbox shown

**TOOLBOX LIGHT**

ITEM	PART NO.	DESCRIPTION	QTY
1	4178000578*	Bracket	1
2	7590000273*	Dome Lamp	1
3	7870000115*	Switch	1
4	7280000007*	Wire Mount Clip	3
5	7661000047*	Panel Nut	4
6	7790100856*	Screw, #10 x 0.50"	4
7	7443000377	Fitting	1
8	7552000297	Toolbox Light Harness	1

\* included in Toolbox Light Bracket Assembly

# TOOLBOX LIGHT

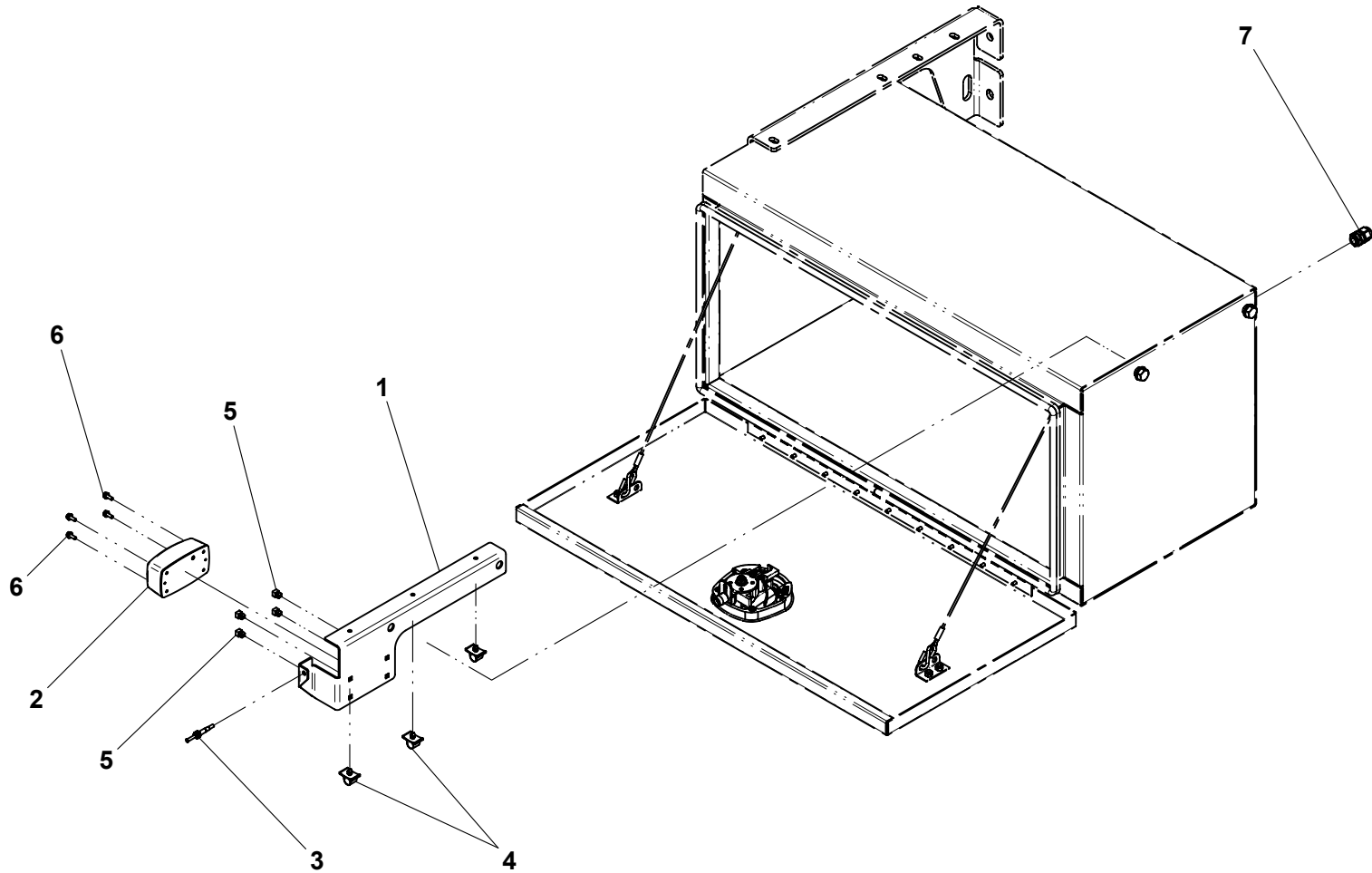

Item #8, Toolbox Light Harness, not shown  
48" Toolbox Shown

**DUAL CONTROLS - 3 BANK**

ITEM	PART NO.	DESCRIPTION	QTY	ITEM	PART NO.	DESCRIPTION	QTY
1	4263000431	Channel	1	29	7949000054	Washer, 0.34" ID	8
2	7950180161	Flatwasher, 0.50" ID	4	30	7330000456	Control Panel, LH	1
3	7660182601	Locknut, 0.50"-13NC	4	31	7330000457	Control Panel, RH	1
4	4263000430	Channel	1	32	7759000006	Pop Rivet	8
5	7790151253	Screw, 0.31"-18NC x 0.75"	12	33	7590000087	Lamp	2
6	3935000115	Control Valve	1	34	7791060872	Screw, #6 x 0.50"	4
7	7111161050	Capscrew, 0.38"-16NC x 1.25"	4	35	7280000007	Wire Clip	11
8	7950160161	Flatwasher, 0.38" ID	4				
9	7660162601	Locknut, 0.38"-16NC	4				
10	4763000280	Control Rod	3				
11	4763000279	Control Rod	3				
12	7690101200	Clevis Pin	3				
13	7691000056	Cotter Pin	3				
14	7115150850	Capscrew, 0.31"-18NC x 1.00"	9				
15	7949000011	Flatwasher, 0.31" ID	9				
16	4831000069	Spacer	9				
17	7660152601	Locknut, 0.31"-18NC	17				
18	4606000065	Lug	4				
19	7115150664	Carriage Bolt, 0.31"-18NC x 0.75"	8				
20	7950150000	Washer, 0.31" ID	8				
21	4691000141	Pin	2				
22	7754000009	Retaining Ring	4				
23	7551000018	Control Handle	2				
24	7551000020	Control Handle	2				
25	7551000021	Control Handle	2				
26	4211000001	Bushing	4				
27	7950220141	Flatwasher, 0.75" ID	2				
28	7560000003	Control Hood	2				

# DUAL CONTROLS - 3 BANK

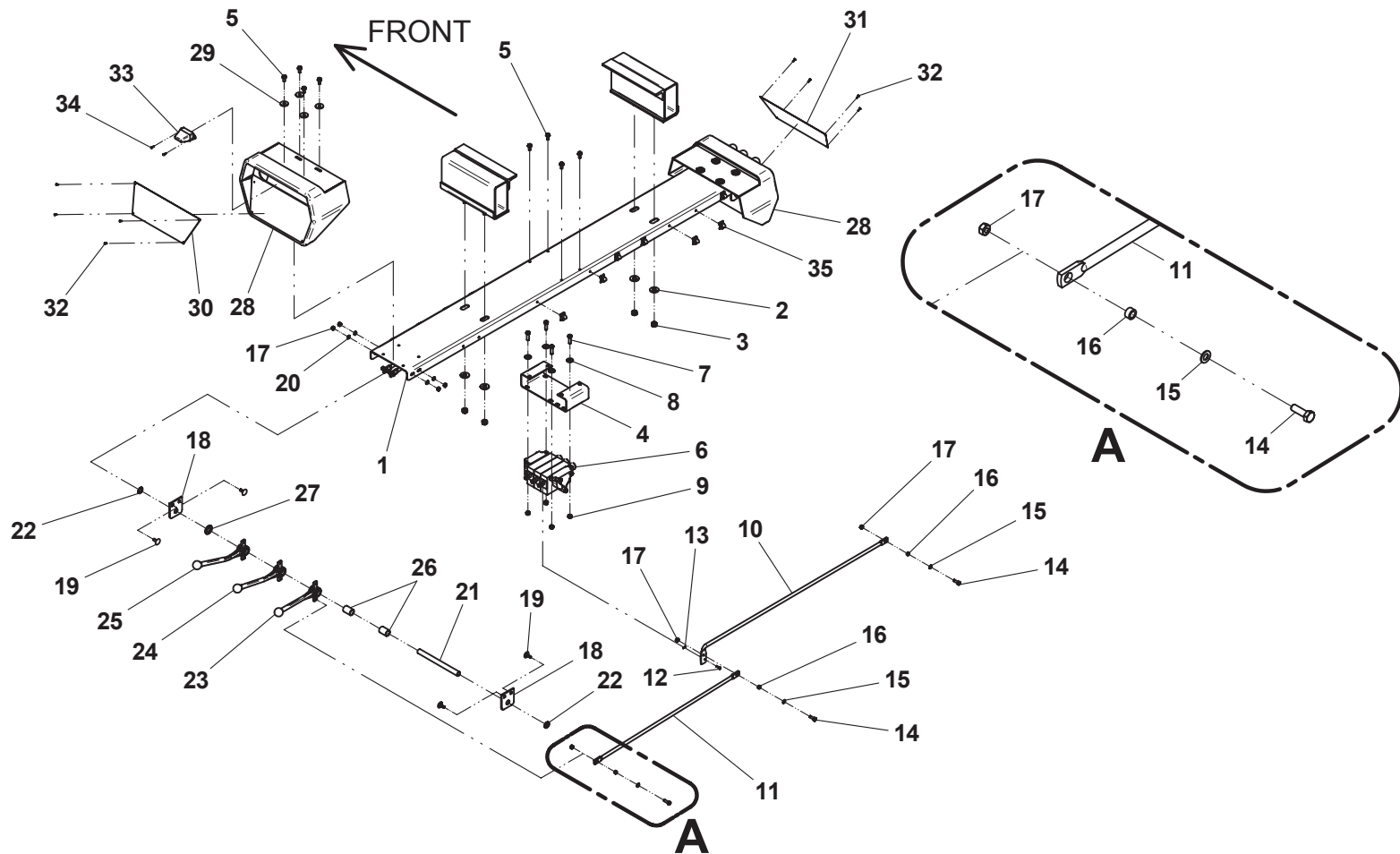

**DUAL CONTROLS - 4 BANK**

ITEM	PART NO.	DESCRIPTION	QTY	ITEM	PART NO.	DESCRIPTION	QTY
1	4263000431	Channel	1	29	7949000054	Washer, 0.34" ID	8
2	7950180161	Flatwasher, 0.50" ID	4	30	7330000458	Control Panel, LH (stabilizer)	1
3	7660182601	Locknut, 0.50"-13NC	4		7330000456	Control Panel, LH (hydraulic tow option)	
4	4263000430	Channel	1	31	7330000459	Control Panel, RH (stabilizer)	1
5	7790151253	Screw, 0.31"-18NC x 0.75"	12		7330000457	Control Panel, RH (hydraulic tow option)	
6	3935000116	Control Valve	1	32	7759000006	Pop Rivet	8
7	7111161050	Capscrew, 0.38"-16NC x 1.25"	4	33	7590000087	Lamp	2
8	7950160161	Flatwasher, 0.38" ID	4	34	7791060872	Screw, #6 x 0.50"	4
9	7660162601	Locknut, 0.38"-16NC	4	35	7280000007	Wire Clip	11
10	4763000280	Control Rod	4				
11	4763000279	Control Rod	4				
12	7690101200	Clevis Pin	4				
13	7691000056	Cotter Pin	4				
14	7115150850	Capscrew, 0.31"-18NC x 1.00"	12				
15	7949000011	Flatwasher, 0.31" ID	12				
16	4831000069	Spacer	12				
17	7660152601	Locknut, 0.31"-18NC	20				
18	4606000065	Lug	4				
19	7115150664	Carriage Bolt, 0.31"-18NC x 0.75"	8				
20	7950150000	Washer, 0.31" ID	8				
21	4691000141	Pin	2				
22	7754000009	Retaining Ring	4				
23	7551000018	Control Handle	2				
24	7551000020	Control Handle	4				
25	7551000021	Control Handle	2				
26	4211000001	Bushing	2				
27	7950220141	Flatwasher, 0.75" ID	2				
28	7560000003	Control Hood	2				

# DUAL CONTROLS - 4 BANK

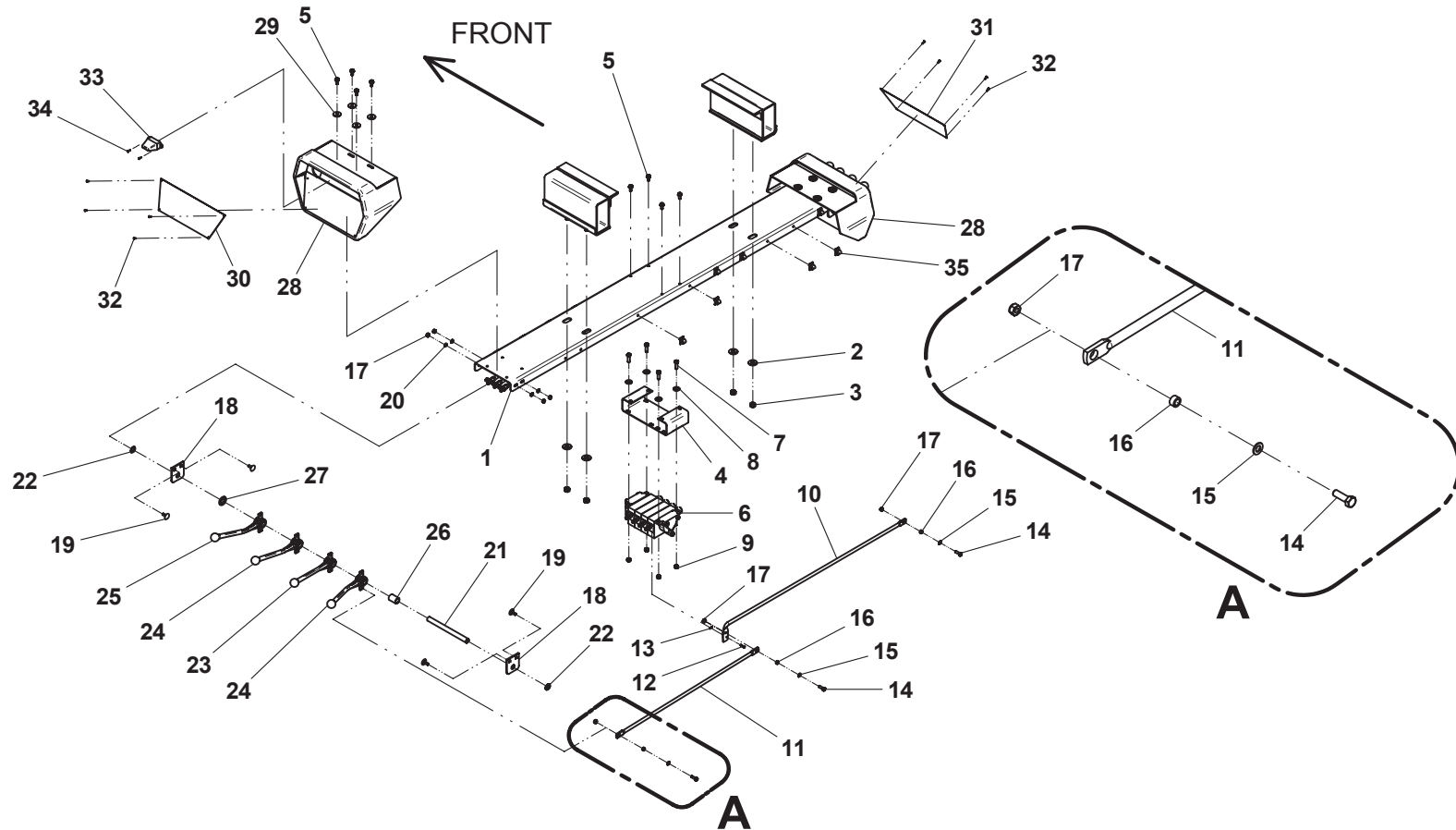

**DUAL CONTROLS - 5 BANK**

ITEM	PART NO.	DESCRIPTION	QTY	ITEM	PART NO.	DESCRIPTION	QTY
1	4263000431	Channel	1	31	7759000006	Pop Rivet	8
2	7950180161	Flatwasher, 0.50" ID	4	32	7590000087	Lamp	2
3	7660182601	Locknut, 0.50"-13NC	4	33	7791060872	Screw, #6 x 0.50"	4
4	4263000430	Channel	1	34	7280000007	Wire Clip	11
5	7790151253	Screw, 0.31"-18NC x 0.75"	12				
6	3935000117	Control Valve	1				
7	7111161050	Capscrew, 0.38"-16NC x 1.25"	4				
8	7950160161	Flatwasher, 0.38" ID	4				
9	7660162601	Locknut, 0.38"-16NC	4				
10	4763000280	Control Rod	5				
11	4763000279	Control Rod	5				
12	7690101200	Clevis Pin	5				
13	7691000056	Cotter Pin	5				
14	7115150850	Capscrew, 0.31"-18NC x 1.00"	15				
15	7949000011	Flatwasher, 0.31" ID	15				
16	4831000069	Spacer	15				
17	7660152601	Locknut, 0.31"-18NC	23				
18	4606000065	Lug	4				
19	7115150664	Carriage Bolt, 0.31"-18NC x 0.75"	8				
20	7950150000	Washer, 0.31" ID	8				
21	4691000141	Pin	2				
22	7754000009	Retaining Ring	4				
23	7551000018	Control Handle	2				
24	7551000020	Control Handle	4				
25	7551000021	Control Handle	4				
26	7950220141	Flatwasher, 0.75" ID	2				
27	7560000003	Control Hood	2				
28	7949000054	Washer, 0.34" ID	8				
29	7330000458	Control Panel, LH (stabilizer)	1				
	7330000456	Control Panel, LH (IRL)					
30	7330000459	Control Panel, RH (stabilizer)	1				
	7330000457	Control Panel, RH (IRL)					



# DUAL CONTROLS - 5 BANK

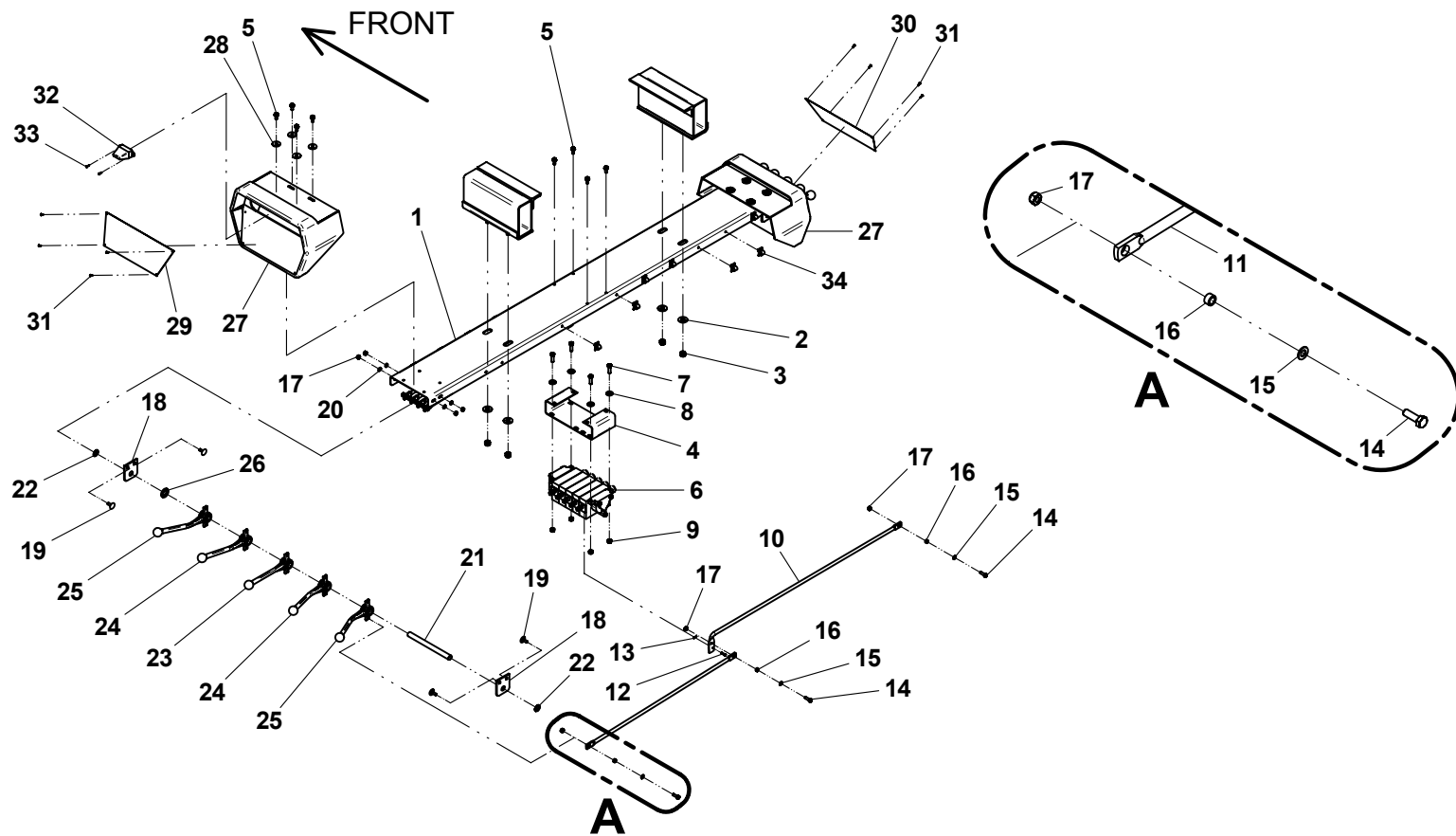

**HYDRAULIC COMPONENTS - STANDARD**

ITEM	PART NO.	DESCRIPTION	QTY	ITEM	PART NO.	DESCRIPTION	QTY
1	See Note 1	PTO	1	31	4569432130	Hose Assembly	1
2	7724000021	Pump	1	32	4567430153	Hose Assembly (24' deck)	2
3	7115181050	Capscrew, 0.50"-13NC x 1.25"	2		4567430177	Hose Assembly (26' deck)	
4	7950180000	Lockwasher, 0.50" ID	2		4567430193	Hose Assembly (28' deck)	
5	7443000101	Adapter	1	33	4570000199	Hose Assembly	1
6	7445081643	Adapter	1	34	4570000201	Hose Assembly (24' & 26' deck)	1
7	7443000023	Elbow	1		4570000202	Hose Assembly (28' deck)	
8	See Note 1	Supply Hose	1	35	4570000200	Hose Assembly	1
9	7443000013	Nipple	1	36	4570000202	Hose Assembly (24' & 26' deck)	1
10	7274000002	Clamp	2		4570000203	Hose Assembly (28' deck)	
11	7430000003	Filter Assembly	1				
12	7470000002	Gauge	1				
13	7443000319	Fitting	1				
14	7274000047	Clamp	2				
15	See Note 1	Return Hose	1				
16	See Note 1	Pressure Hose Assembly	1				
17	7443000168	Adapter	1				
18	7445081045	Elbow	3				
19	Not Required						
20	7445080843	Adapter	2				
21	7445060843	Adapter	4				
22	4567123044	Hose Assembly	1				
23	4567122040	Hose Assembly	1				
24	7445060645	Elbow	5				
25	7445060643	Adapter	3				
26	4567122144	Hose Assembly (24' & 26' deck)	1				
	4567122186	Hose Assembly (28' deck)					
27	4567123144	Hose Assembly (24' & 26' deck)	1				
	4567123186	Hose Assembly (28' deck)					
28	7935000306	Dual Countebalance Valve	1				
29	7431000001*	Filter Element	1				
30	4569433130	Hose Assembly	1				

\* also available in Filter Assembly, P/N 7430000003

Note 1: Varies depending on chassis, transmission , PTO type & deck length.  
Consult factory for part numbers.

# HYDRAULIC COMPONENTS - STANDARD

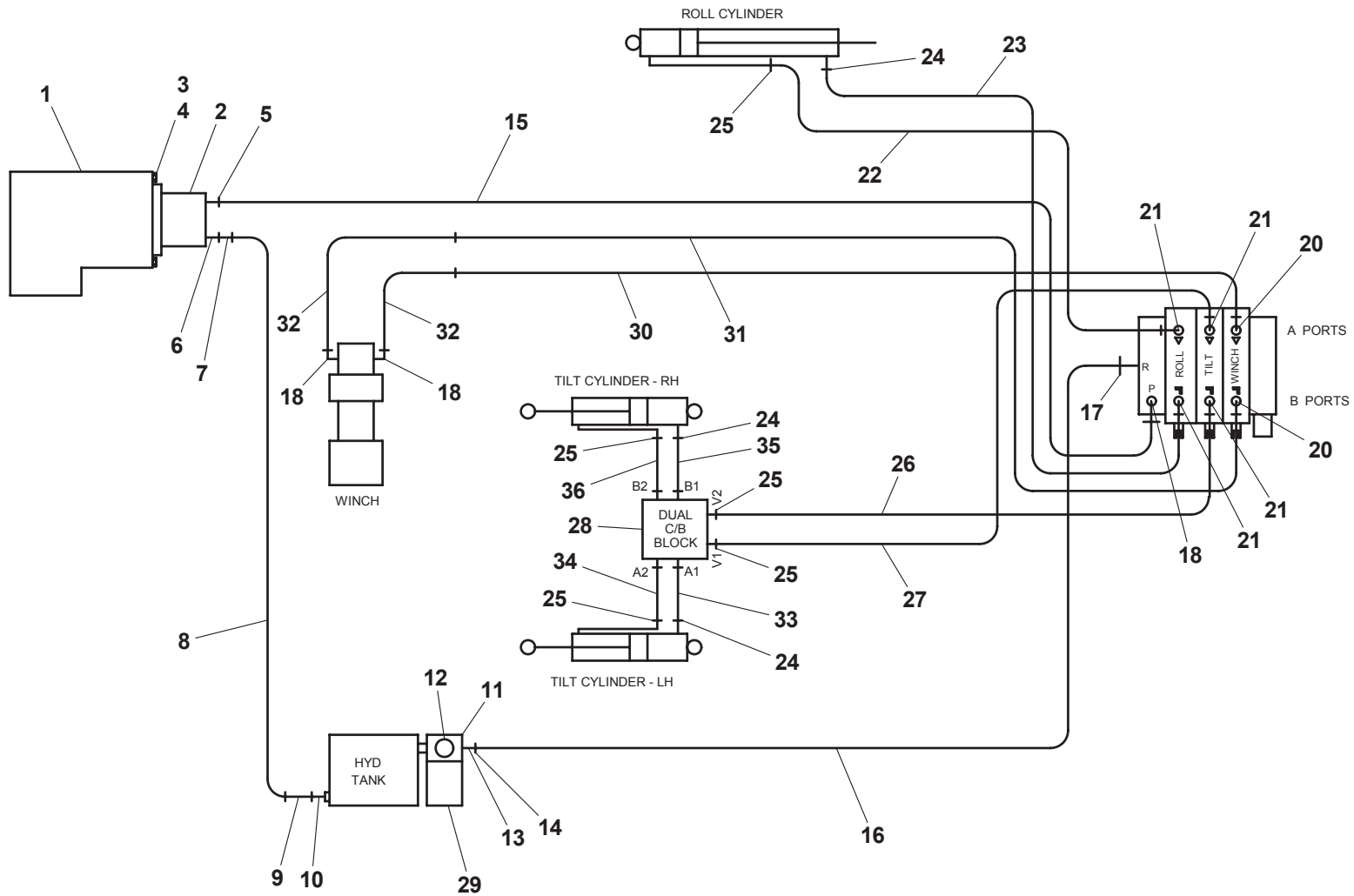

**HYDRAULIC COMPONENTS - STANDARD (HOSE TRACK)**

ITEM	PART NO.	DESCRIPTION	QTY
1	7904000001	Hose Track (24' & 26' deck)	1
	7904000003	Hose Track (28' deck)	
2	4706003038	Plate	1
3	7114101618	Capscrew #10-24NC x 2.00"	4
4	7660102604	Locknut, #10-24NC	4
5	7274000038	Clamp	4
6	7274000039	Clamp Cover	2
7	7115151650	Capscrew, 0.31"-18NC x 2.00"	2
8	7950150161	Flatwasher, 0.31" ID	2
9	7660152601	Locknut, 0.31"-13NC (24' deck)	10
	7660152601	Locknut, 0.31"-13NC (26' deck)	11
	7660152601	Locknut, 0.31"-13NC (28' deck)	12
10	7894000004	Tie Strap	5
11	7935000197	Counterbalance Valve	1
12	7115151850	Capscrew, 0.31"-18NC x 2.25"	2
13	7274000066	Double Clamp (24' deck)	5
	7274000066	Double Clamp (26' deck)	6
	7274000066	Double Clamp (28' deck)	7
14	7280000013	Clip	*

\* Quantity varies depending on deck length and deck type.

# HYDRAULIC COMPONENTS - STANDARD (HOSE TRACK)

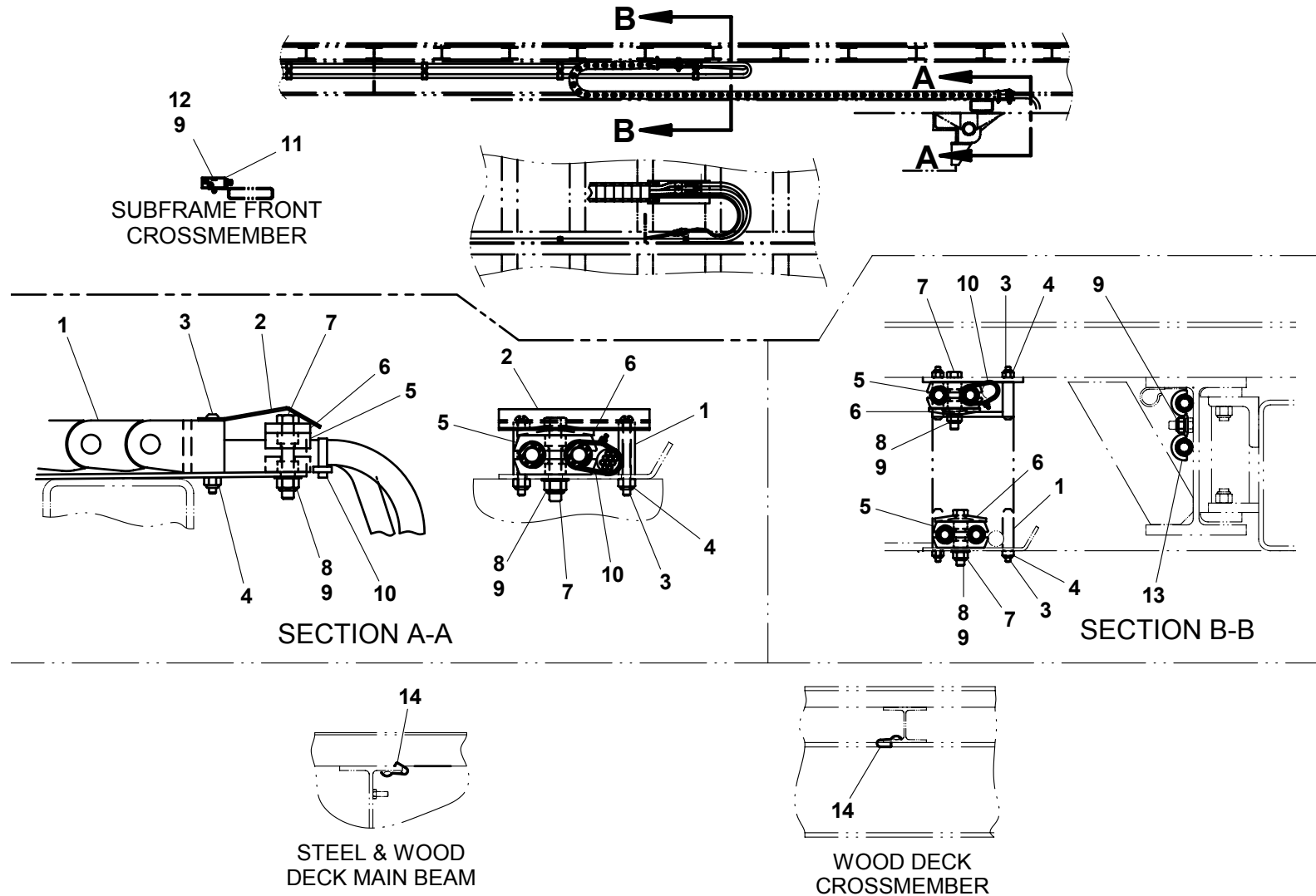

**HYDRAULIC COMPONENTS - HOSE ROUTING / MOUNTING**

ITEM	PART NO.	DESCRIPTION	QTY
1	7274000076	Cast Frame Clamp	*
2	7785152420	Set Screw, 0.31"-18NC x 1.50"	*
3	7660152601	Locknut, 0.31"-18NC	*
4	7115151050	Capscrew, 0.31"-18NC x 1.25"	*
5	7950150161	Flatwasher, 0.31" ID	*
6	7274000040	Clamp	*
7	7274000041	Clamp	*
8	7274000042	Clamp	*

\* Quantity varies depending on deck length and deck type

# HYDRAULIC COMPONENTS - HOSE ROUTING / MOUNTING

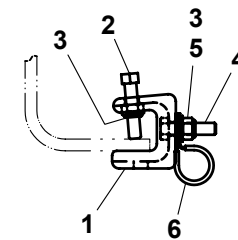
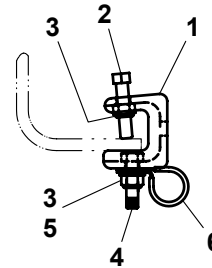
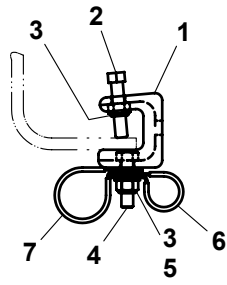
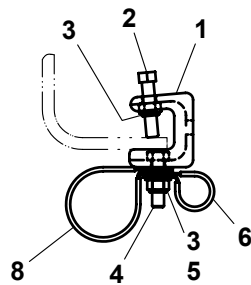
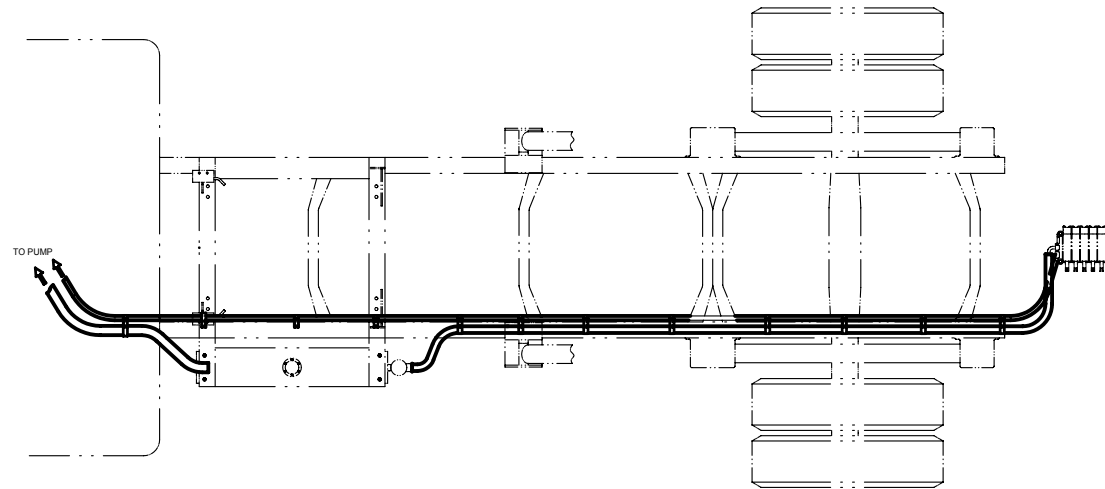

TYPICAL HOSE ROUTING / MOUNTING

**HYDRAULIC COMPONENTS - IRL WHEEL LIFT W/ MAN GRIDS OR IRL BALL / PINTLE HITCH MTG PLT**

ITEM	PART NO.	DESCRIPTION	QTY
1	7443000129	Reducer	2
2	7445060648	Tee	4
3	4567123045	Hose Assembly	2
4	4567122043	Hose Assembly	2
5	7935000305	Counterbalance Valve	2
6	7445060645	Elbow	4
7	4567122014	Hose Assembly	2
8	7443040643	Adapter	2
9	4567110034	Hose Assembly	2
10	7445040446	Elbow	2



# HYDRAULIC COMPONENTS - IRL WHEEL LIFT W/ MAN GRIDS OR IRL BALL / PINTLE HITCH MTG PLT

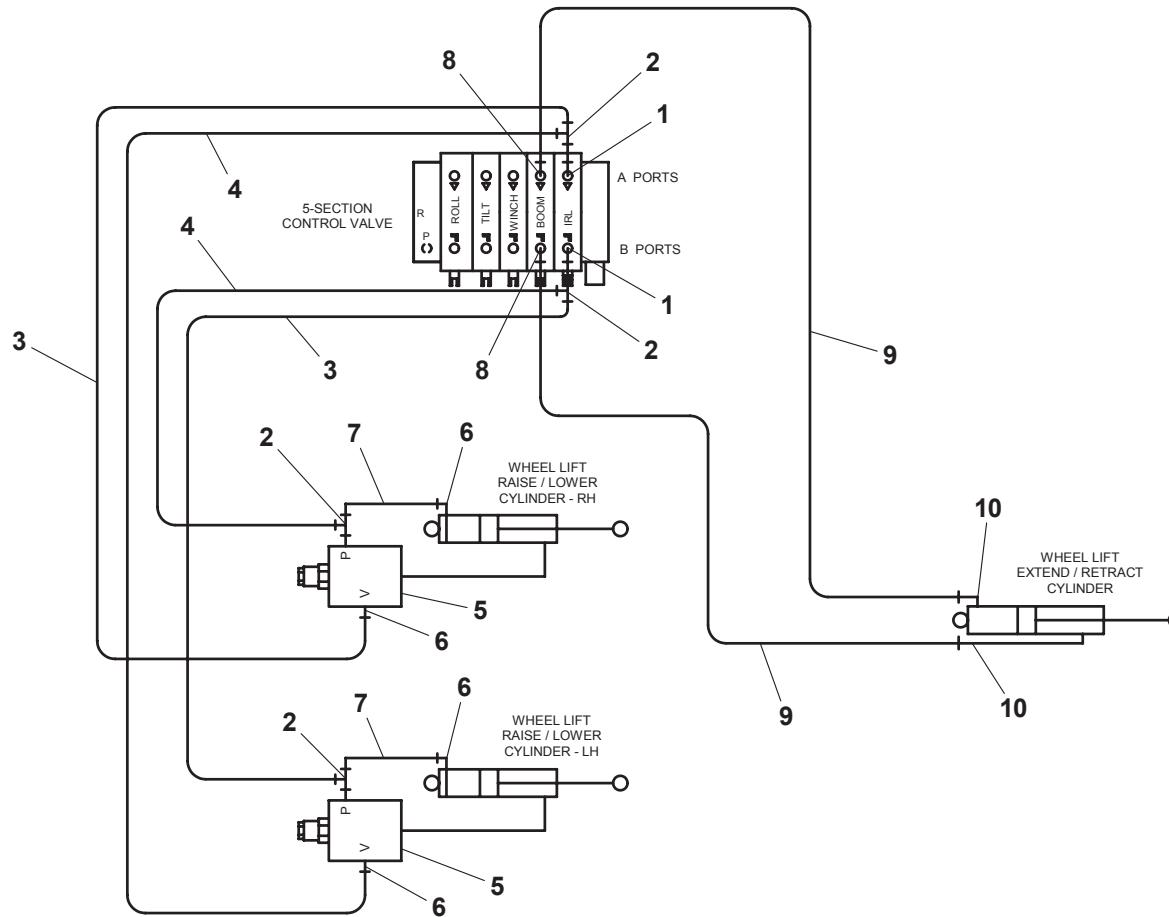

**HYDRAULIC COMPONENTS - HYDRAULIC REAR DOCK STABILIZER**

ITEM	PART NO.	DESCRIPTION	QTY
1	7445060843	Adapter	2
2	4567122035	Hose Assembly	2
3	7445060637	Tee	2
4	4567120019	Hose Assembly	4
5	7445060645	Elbow	4

# HYDRAULIC COMPONENTS - HYDRAULIC REAR DOCK STABILIZER

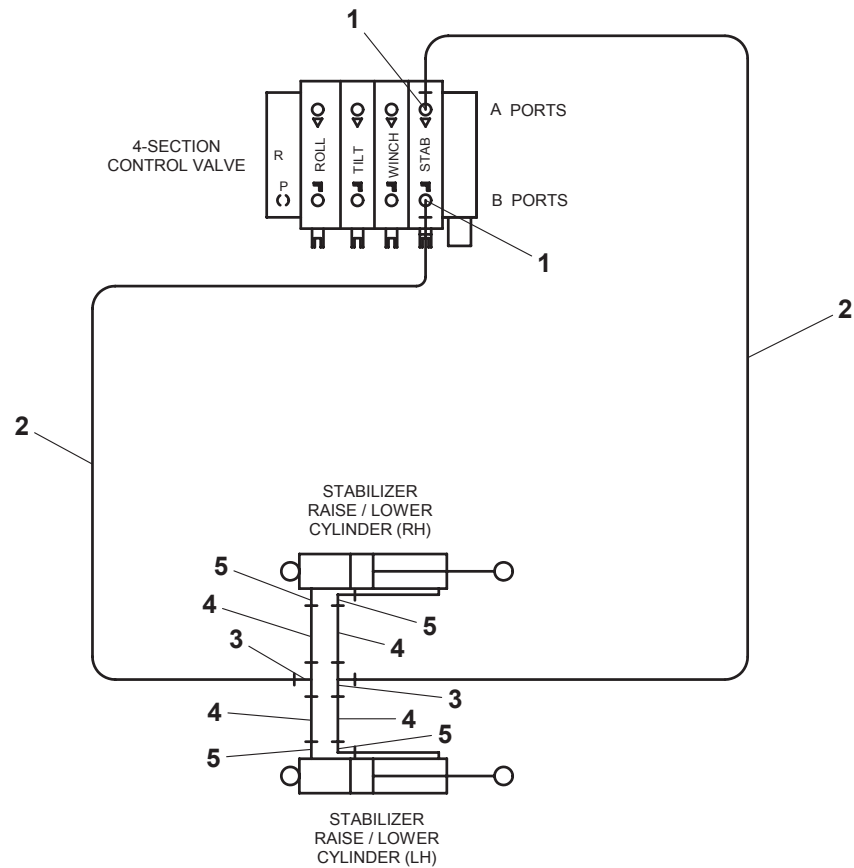

**HYDRAULIC COMPONENTS - STABILIZER W/ REESE HITCH RECEIVER OR PINTLE HITCH MTG PLT**

ITEM	PART NO.	DESCRIPTION	QTY
1	7445060845	Elbow	2
2	7443000030	Tee	2
3	4567123050	Hose Assembly	2
4	4567122046	Hose Assembly	2
5	7935000305	Counterbalance Valve	2
6	7445060648	Tee	2
7	7445060645	Elbow	4
8	4567122014	Hose Assembly	2

# HYDRAULIC COMPONENTS - STABILIZER W/ REESE HITCH RECEIVER OR PINTLE HITCH MTG PLT

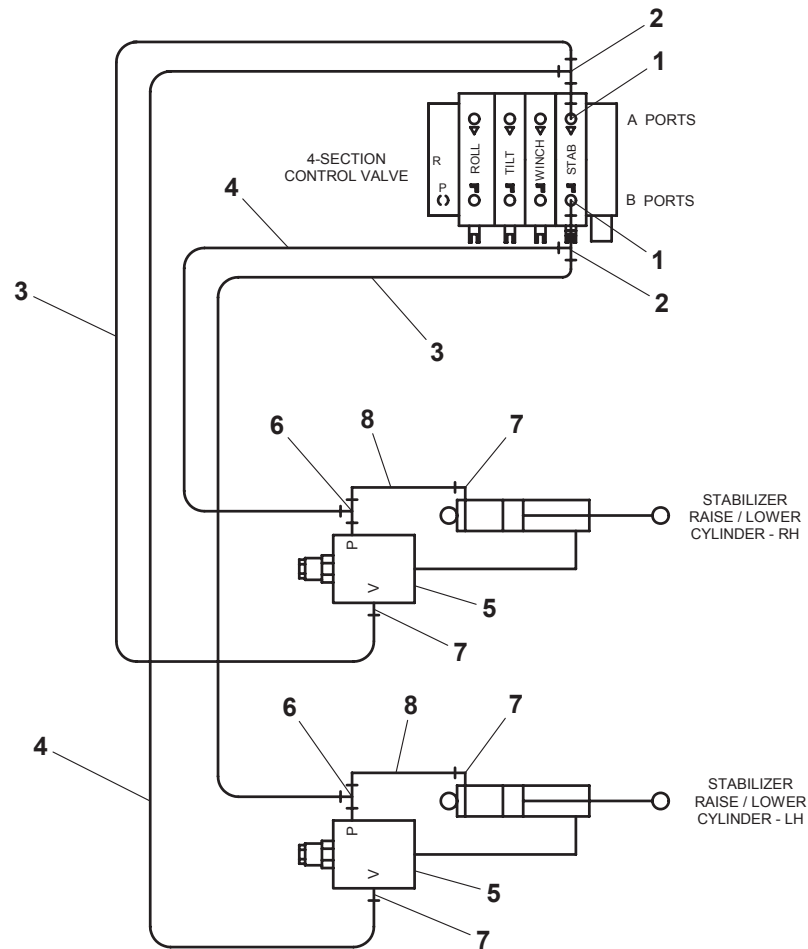

**HYDRAULIC COMPONENTS - STABILIZER W/ HYDRAULIC PINTLE HITCH MOUNTING PLATE**

ITEM	PART NO.	DESCRIPTION	QTY
1	7445060843	Adapter	2
2	7445060845	Elbow	2
3	7443000030	Tee	2
4	4567123050	Hose Assembly	2
5	4567122046	Hose Assembly	2
6	7935000305	Counterbalance Valve	2
7	7445060645	Elbow	4
8	7445060648	Tee	2
9	4567122014	Hose Assembly	2
10	4567120034	Hose Assembly	2
11	7445060646	Elbow	2

# HYDRAULIC COMPONENTS - STABILIZER W/ HYDRAULIC PINTLE HITCH MOUNTING PLATE

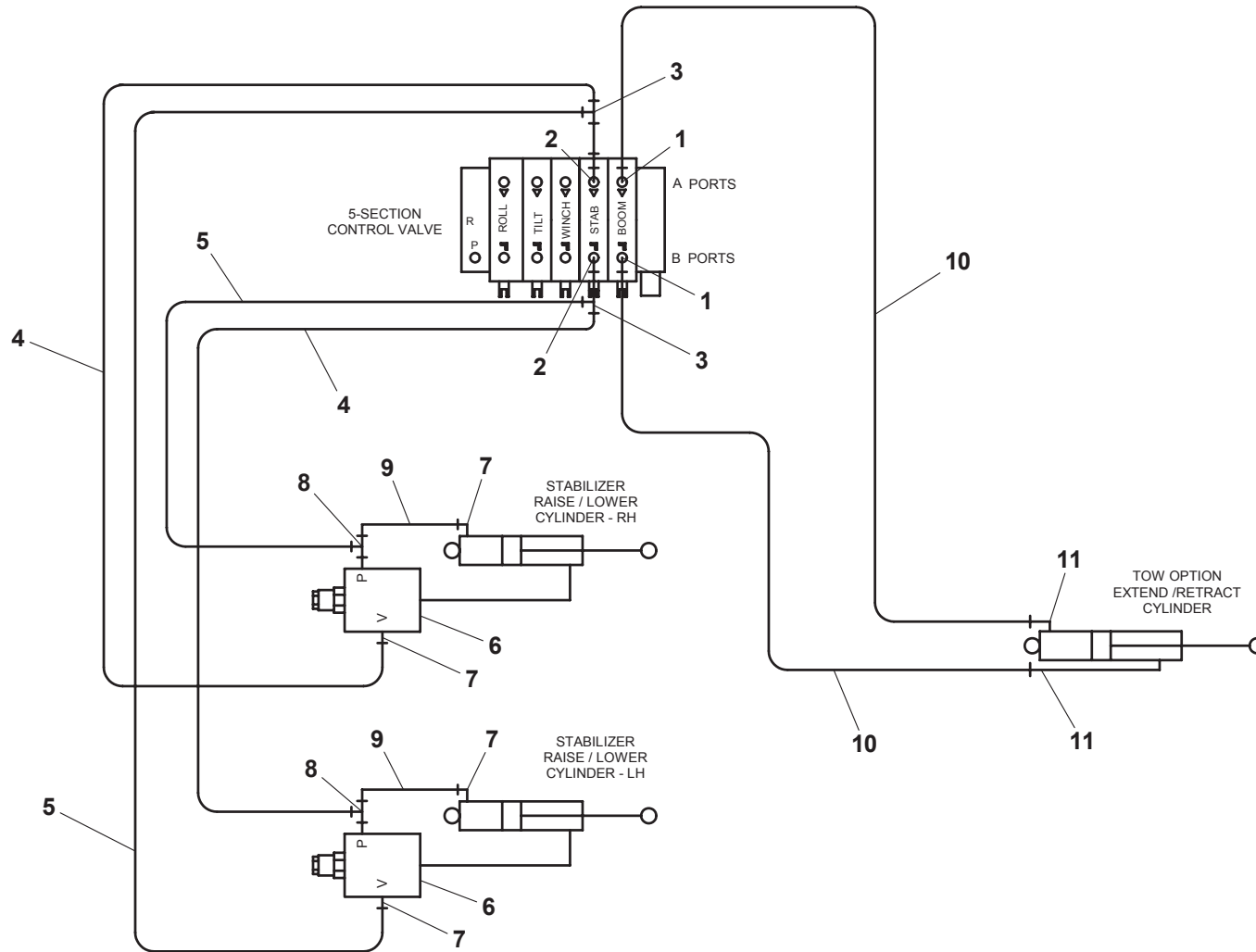

**HYDRAULIC COMPONENTS - STABILIZER W/ IRL WHEEL LIFT**

ITEM	PART NO.	DESCRIPTION	QTY
1	7443000129	Reducer	2
2	7445060648	Tee	4
3	4567123050	Hose Assembly	2
4	4567122046	Hose Assembly	2
5	7935000305	Counterbalance Valve	2
6	7445060645	Elbow	4
7	4567122014	Hose Assembly	2
8	7445040843	Adapter	2
9	4567110034	Hose Assembly	2
10	7445040445	Elbow	2



# HYDRAULIC COMPONENTS - STABILIZER W/ IRL WHEEL LIFT

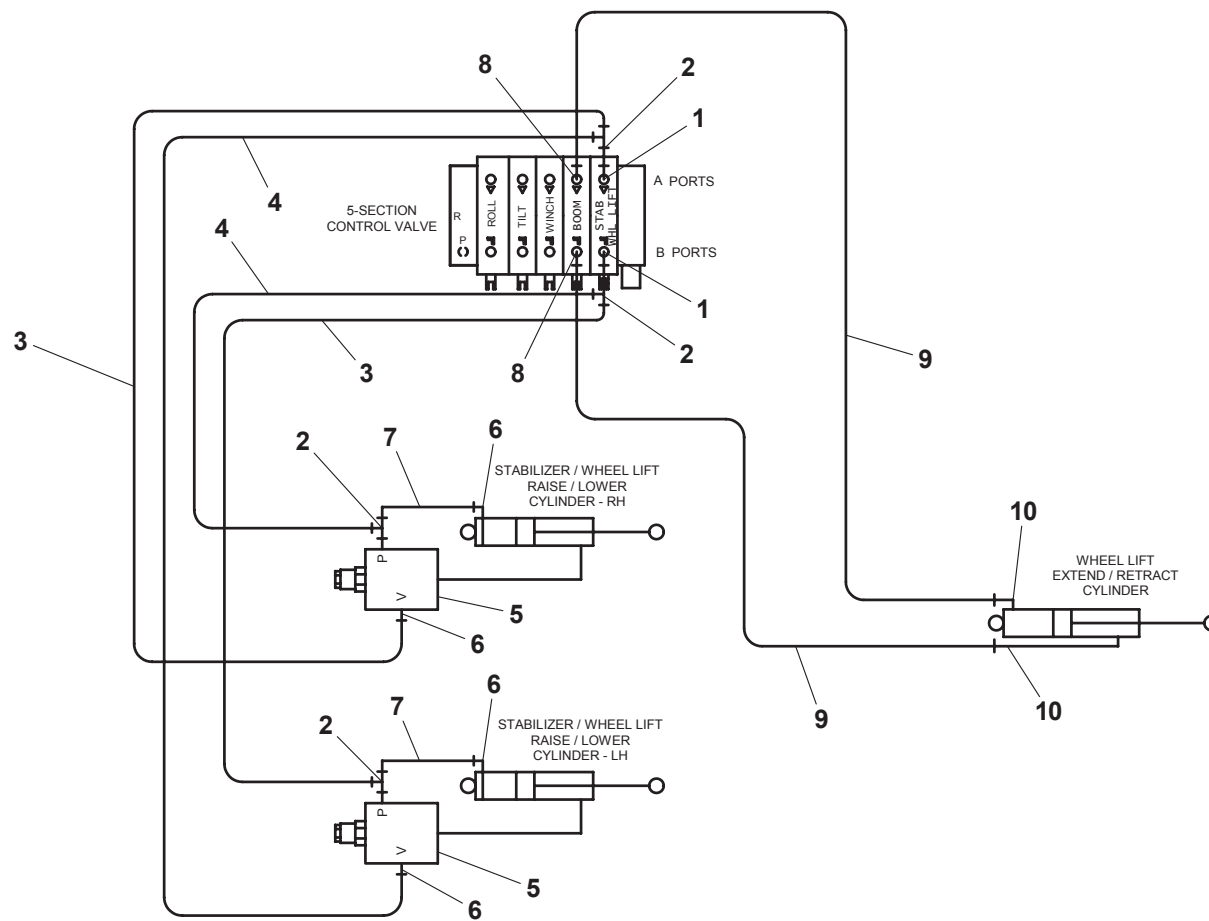

**HYDRAULIC COMPONENTS - IRL TOWBAR**

ITEM	PART NO.	DESCRIPTION	QTY
1	7445060845	Elbow	2
2	7443000030	Tee	2
3	4567123050	Hose Assembly	2
4	4567122046	Hose Assembly	2
5	7935000305	Counterbalance Valve	2
6	7445060645	Elbow	4
7	4567122014	Hose Assembly	2
8	7445060843	Adapter	2
9	4567122042	Hose Assembly	2
10	7445060643	Adapter	2
11	7445060648	Tee	2

# HYDRAULIC COMPONENTS - IRL TOWBAR

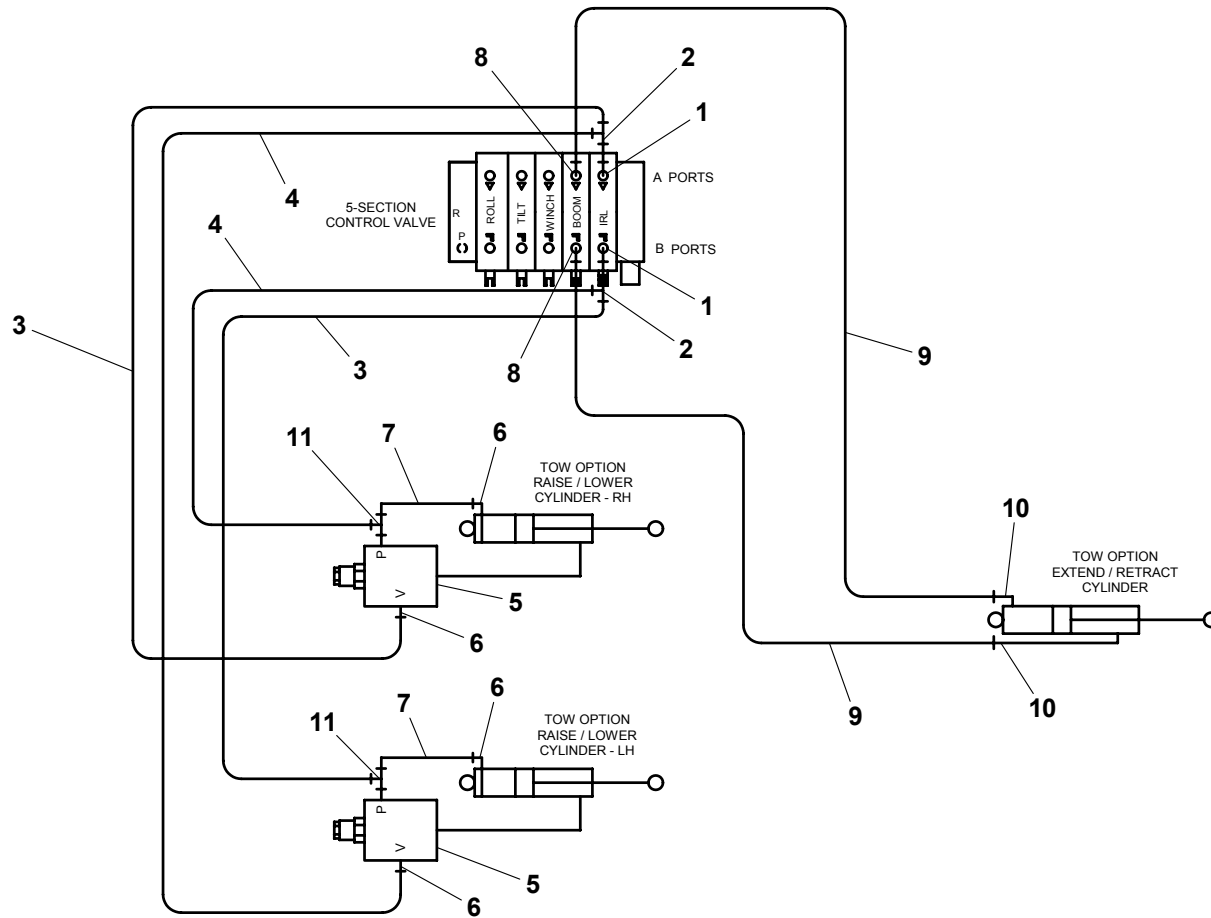

**HYDRAULIC COMPONENTS - HYDRAULIC EXTEND TOW OPTION**

ITEM	PART NO.	DESCRIPTION	QTY
1	7445060843	Adapter	2
2	4567122042	Hose Assembly	2
3	7445060643	Adapter	2

# HYDRAULIC COMPONENTS - HYDRAULIC EXTEND TOW OPTION

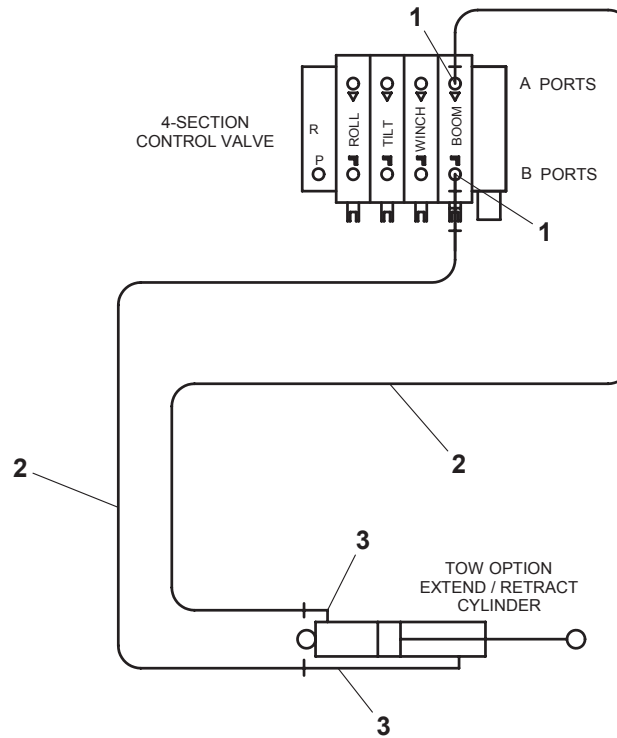

**ELECTRICAL COMPONENTS - STANDARD W/ BOLT-ON HEADBOARD**

ITEM	PART NO.	DESCRIPTION	QTY
1	7552000186	Subframe to Deck Harness (units with pre-wiring)	1
	7552000190	Subframe to Deck Harness (units without pre-wiring)	
2	7552000074	Subframe to Cab Harness (24' deck) (units with pre-wiring)	1
	7552000178	Subframe to Cab Harness (26' & 28' deck) (units with pre-wiring)	
	Not Required	(Units Without Prewiring)	
3	7552000135	Subframe Harness	1
4	7552000187	Subframe to Deck Aux Harness (24' & 26' deck)(units with pre-wiring)	1
	7552000188	Subframe to Deck Aux Harness (28' deck)(units with pre-wiring)	
	7552000191	Subframe to Deck Aux Harness (24' & 26' deck)(units without pre-wiring)	
	7552000192	Subframe to Deck Aux Harness (28' deck)(units without pre-wiring)	
5	7552000179	Deck Harness (24' deck)	1
	7552000181	Deck Harness (26' & 28' deck)	
6	7552000166	Winch Lights Harness	1
7	7552000222	Worklights on Headboard Harness	1
8	7345241902	Terminal	1
9	7457000004	Circuit Breaker	1
10	7790100856	Screw, #10 x 0.50"	2
11	7345221902	Terminal	2
12	7950100151	Flatwasher, 0.19" ID	2
13	7280000013	Clip	*
14	3590000015	Wiring Connector Kit (Ford & GMC chassis)	1
	3590000017	Wiring Connector Kit (UD chassis)	

\* Quantity varies depending on deck construction.

# ELECTRICAL COMPONENTS - STANDARD W/ BOLT-ON HEADBOARD

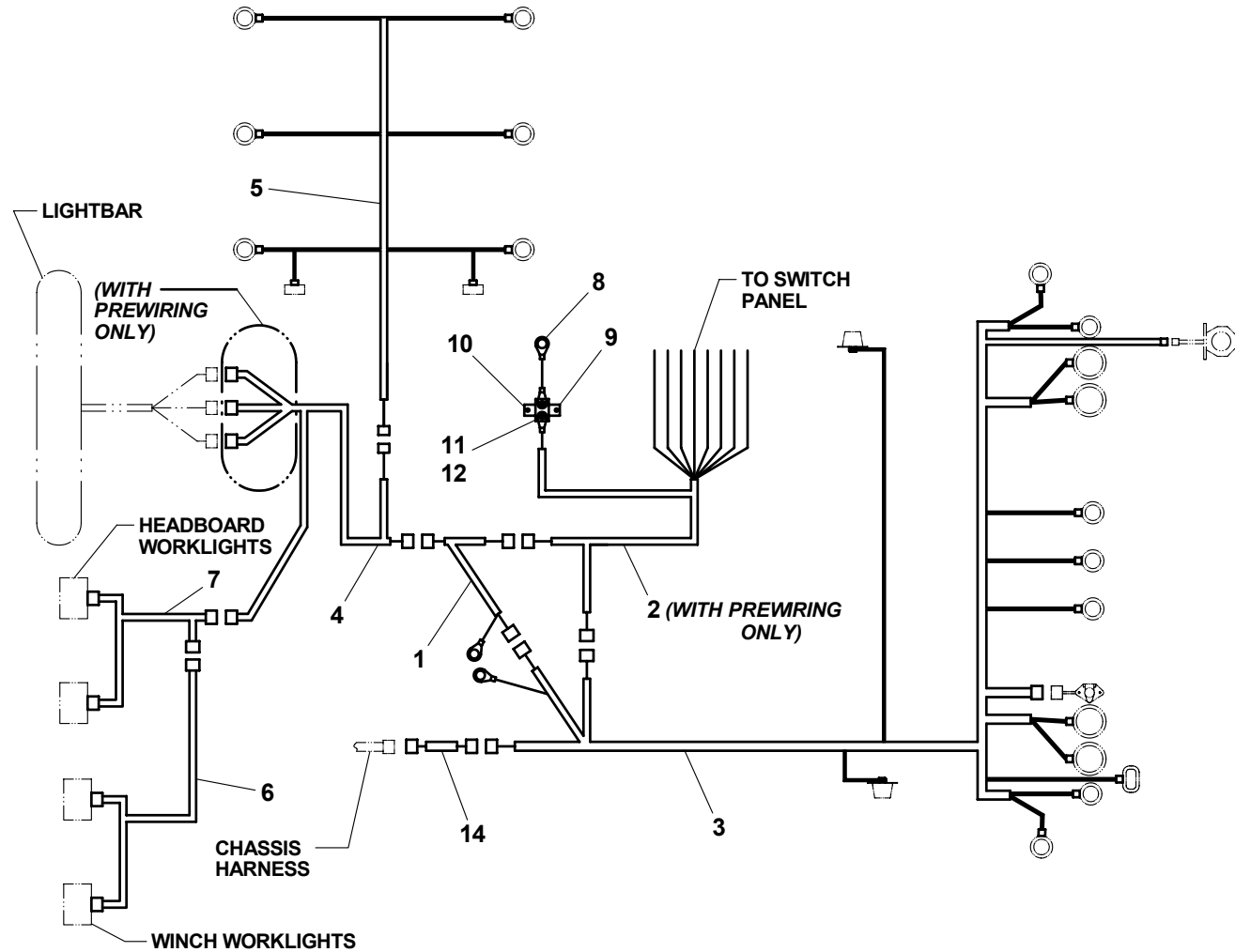

Item #13, Clip, not shown.

**ELECTRICAL COMPONENTS - STANDARD W/ STATIONARY HEADBOARD**

ITEM	PART NO.	DESCRIPTION	QTY
1	7552000302	Subframe to Cab Harness	1
2	7552000190	Subframe to Deck Harness	1
3	7552000135	Subframe Harness	1
4	7552000179	Deck Harness (24' deck)	1
	7552000181	Deck Harness (26' & 28' decks)	
5	7552000191	Subframe to Deck Aux Harness (24' deck)	1
	7552000192	Subframe to Deck aux Harness (26' & 28' decks)	
6	7552000166	Worklights on Winch Harness	1
7	7345241902	Terminal	1
8	7457000004	Circuit Breaker	1
9	7790100856	Screw, #10 x 0.50"	2
10	7345221902	Terminal	2
11	7950100151	Flatwasher, 0.19" ID	2
12	7280000013	Clip	*
13	3590000015	Wiring Connector Kit	1

\* Quantity varies depending on deck construction.



# ELECTRICAL COMPONENTS - STANDARD W/ STATIONARY HEADBOARD

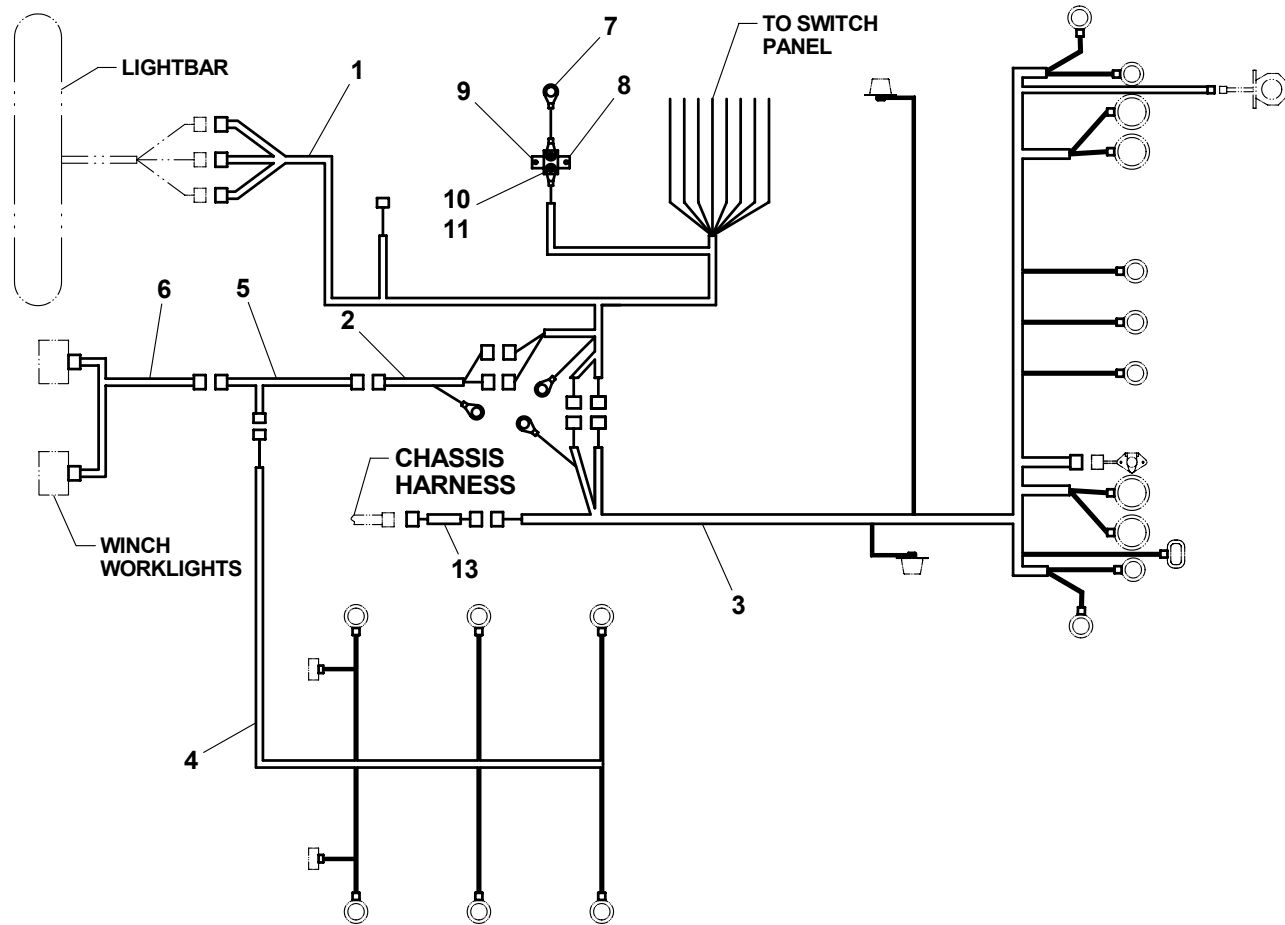

Item #12, Clip, not shown.

**ELECTRICAL COMPONENTS - OPTIONAL (TAIL LIGHT CONVERTER)**

ITEM	PART NO.	DESCRIPTION	QTY
1	7297000008	Taillight Converter	1
2	4706002990	Plate	1
3	7661000007	Wellnut	4
4	7104100613	Screw, #10-32NF x 0.75"	4
5	7790151253	Screw, 0.31"-18NC x 1.50"	2
6	7345001714	Terminal	5
7	4346000005	Heak Shrink Tubing - 1.50"	5
8	7345221902	Terminal	1
9	7345241902	Terminal	1
10	7346000126	Fuse Holder	1
11	7457000017	Fuse - 30 amp	1
12	7345001914	Terminal	1

# ELECTRICAL COMPONENTS - OPTIONAL (TAIL LIGHT CONVERTER)

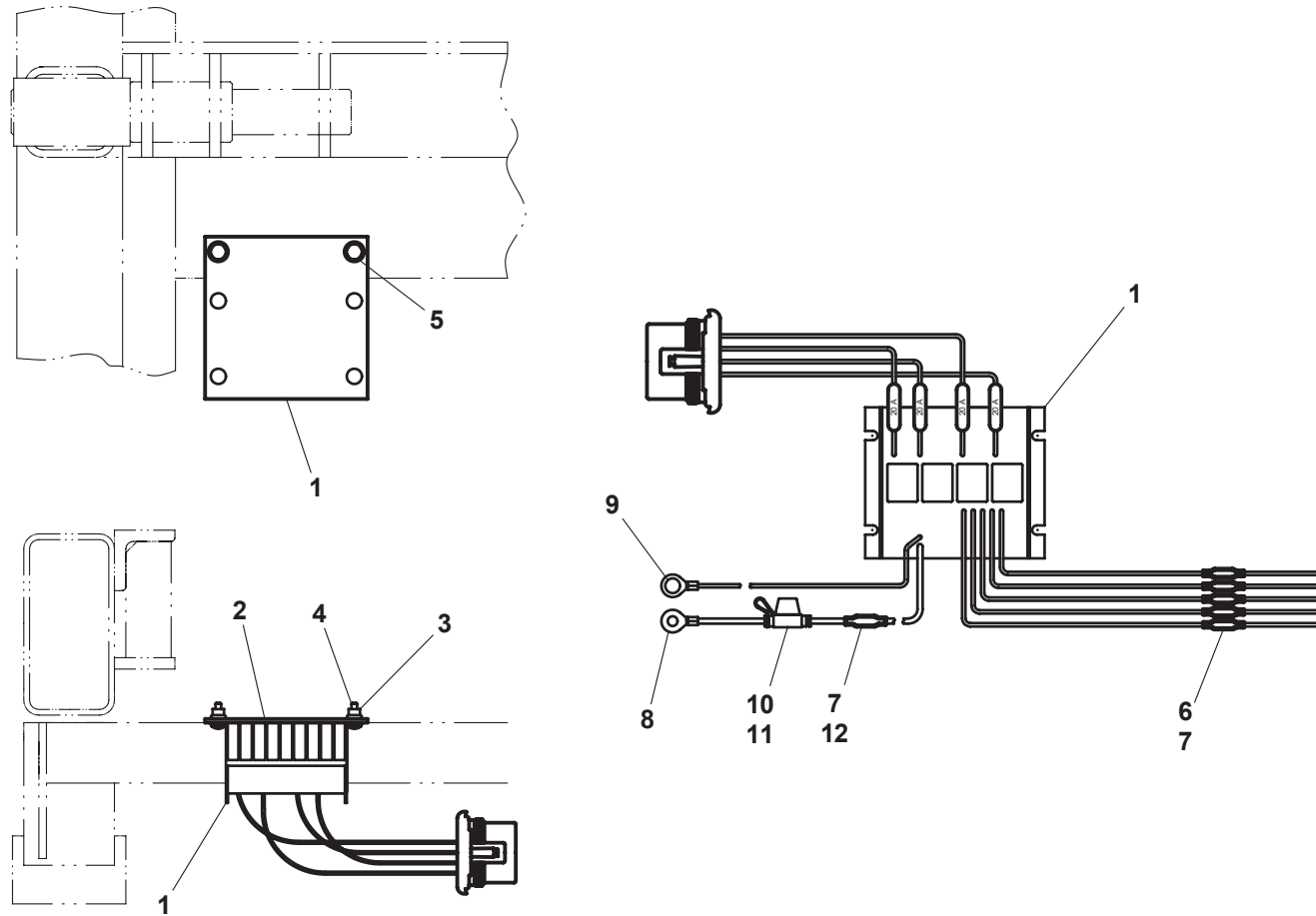

**IRL WHEEL LIFT**

ITEM	PART NO.	DESCRIPTION	QTY	ITEM	PART NO.	DESCRIPTION	QTY
1	3170000162	Outer Boom Weld (3,000 lb wheel lift)	1	23	7082000016^	Bearing	4
	3170000163	Outer Boom Weld (4,000 lb wheel lift)		24	7291000003	4-Way Receptacle	1
2	3911000056	Inner Boom Weld (3,000 lb wheel lift)	1	25	7796000048	Gasket	1
	3170000304	Inner Boom Weld (4,000 lb wheel lift)		26	7114140528	Screw, 0.25"-20NC x 0.63"	2
3	3320000115	Cylinder Assembly	1	27	7660142601	Locknut, 0.25"-20NC	2
4	4691000296	Pin	1				
5	4691000268	Pin	1				
6	7754000006	Retaining Ring	4				
7	7082000020*	Bushing (3,000 lb wheel lift)	1				
	7082000021<	Bushing (4,000 lb wheel lift)					
8	4679000046	Wear Pad	1				
9	4017000739	Angle	2				
10	7118140418	Capscrew, 0.25"-20NC x 0.50"	4				
11	7950100151	Washer, 0.19" ID	4				
12	4679000211	Wear Pad	1				
13	3320000123	Cylinder Assembly (3,000 lb wheel lift)	2				
	3320000124	Cylinder Assembly (4,000 lb wheel lift)					
14	3691000164	Pin Weld	2				
15	7115160950	Capscrew, 0.38"-16NC x 1.12"	6				
16	7660162601	Locknut, 0.38"-16NC	6				
17	3691000073	Pin Weld	3				
18	3020000105	Arm Weld (3,000 lb wheel lift)	2				
	3020000106	Arm Weld (4,000 lb wheel lift)					
19	7082000019+	Bearing	2				
20	7082000018+	Bearing	2				
21	3592000039	Link Assembly (3,000 lb wheel lift)	1				
	3592000040	Link Assembly (4,000 lb wheel lift)					
22	3691000069	Pin Weld	1				

+ included in Arm Weld, P/Ns 3020000105 & 3020000106

^ included in Link Weld, P/Ns 359 2000034, 3592000041 & 3592000042

< included in Inner Boom Weld, P/N 3911000304

\* included in Inner Boom Weld, P/N 3911000056

# IRL WHEEL LIFT

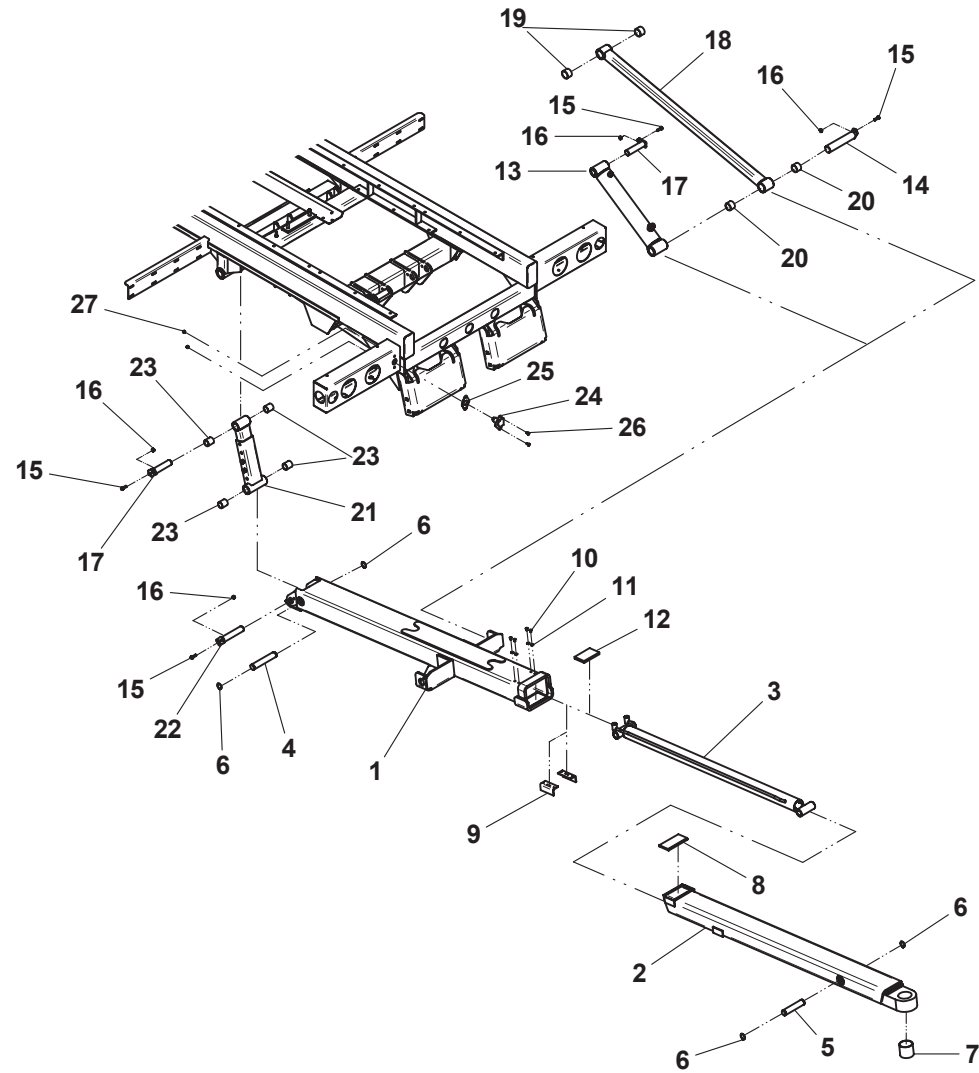

3,000 lb wheel lift shown

**MANUAL L-ARM WHEEL LIFT GRID**

ITEM	PART NO.	DESCRIPTION	QTY
1	3913000093	Pivot Tube Weld (3,000 lb IRL wheel lift w/ ball plate)	1
	3913000097	Pivot Tube Weld (4,000 lb IRL wheel lift w/ ball plate)	
	3913000098	Pivot Tube Weld (3,000 lb IRL wheel lift w/ 2" pintle)	
	3913000100	Pivot Tube Weld (4,000 lb IRL wheel lift w/ 2" pintle)	
	3913000101	Pivot Tube Weld (4,000 lb IRL wheel lift w/ 2.5" pintle)	
2	3484000035	Grid Weld - LH (3,000 lb wheel lift)	1
	3484000031	Grid Weld - LH (4,000 lb wheel lift)	
3	3484000034	Grid Weld - RH (3,000 lb wheel lift)	1
	3484000030	Grid Weld - RH (4,000 lb wheel lift)	
4	4691000447	Pivot Pin (3,000 lb wheel lift)	1
	4691000427	Pivot Pin (4,000 lb wheel lift)	
5	4949000047	Washer	2
6	7754000024	Retaining Ring	1
7	3551000036	T-Handle	2
8	3020000072	L-Arm Weld (3,000 lb wheel lift)	1
	3020000037	L-Arm Weld LH (4,000 lb wheel lift)	
9	7701000062	Plug (3,000 lb wheel lift)	2
10	3551000011	Cam Lock Assembly	2
11	7440030000	Grease Fitting	2
12	7330000419	Reflective Tape	2
13	7330000417	Reflective Tape - LH	1
14	7330000418	Reflective Tape - RH	1
15	3020000072	L-Arm Weld (3,000 lb wheel lift)	1
	3020000038	L-Arm Weld RH (4,000 lb wheel lift)	

# MANUAL L-ARM WHEEL LIFT GRID

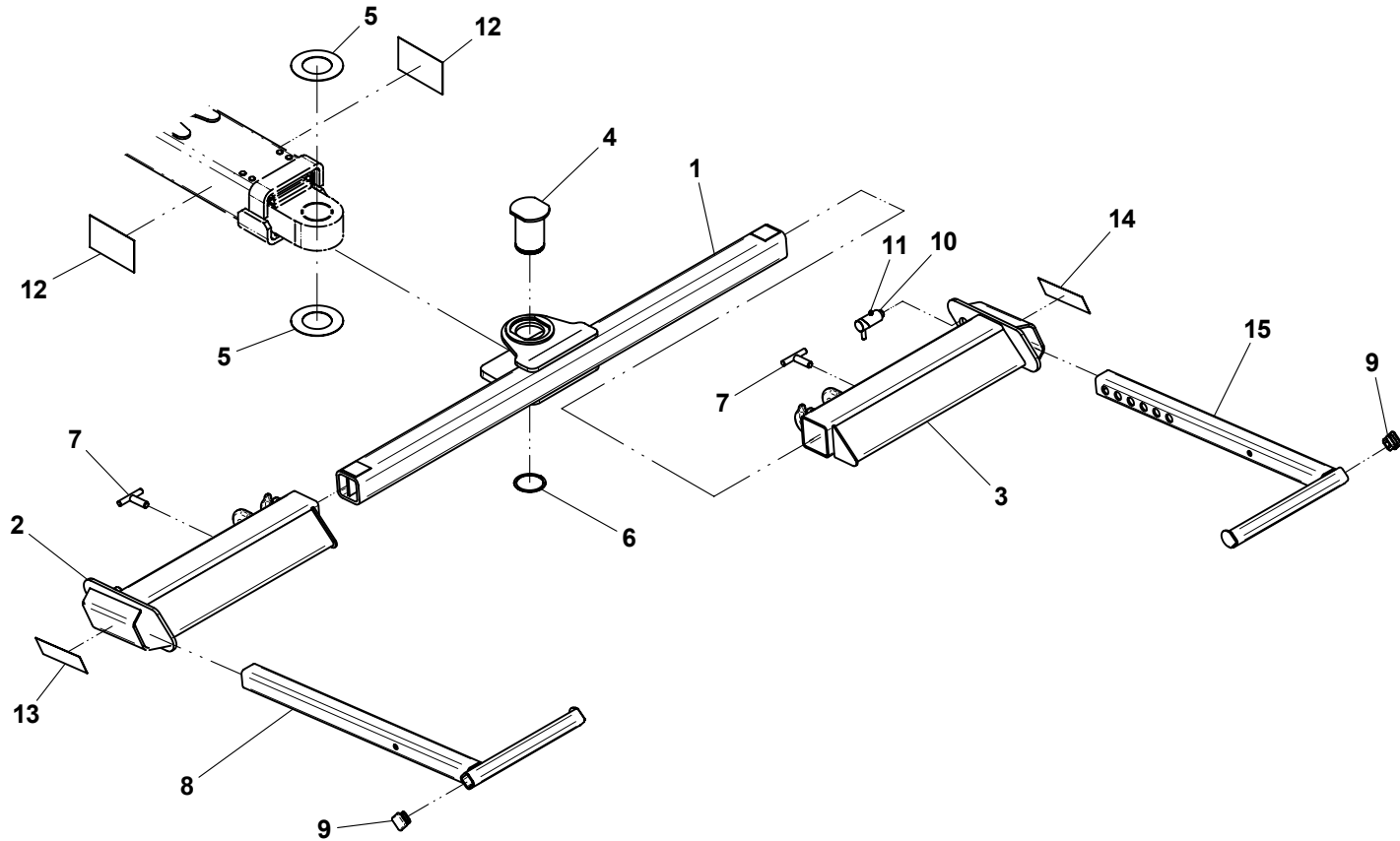

3,000 lb wheel lift grid shown

**MANUAL T37 PIVOTING WHEEL LIFT GRID**

ITEM	PART NO.	DESCRIPTION	QTY	ITEM	PART NO.	DESCRIPTION	QTY
1	3913000093	Pivot Tube Weld (3,000 lb IRL wheel lift w/ ball plate)	1	21	3020000029	L-Arm Weld - LH	1
	3913000097	Pivot Tube Weld (4,000 lb IRL wheel lift w/ ball plate)		22	3020000030	L-Arm Weld - RH	1
	3913000098	Pivot Tube Weld (3,000 lb IRL wheel lift w/ 2" pintle)		23	7330000419	Reflective Tape	2
	3913000100	Pivot Tube Weld (4,000 lb IRL wheel lift w/ 2" pintle)		24	7330000420	Reflective Tape	1
	3913000101	Pivot Tube Weld (4,000 lb IRL wheel lift w/ 2.5" pintle)		25	7330000432	Reflective Tape	1
				26	7950200000~	Lockwasher, 0.63" ID	2
2	3484000051*	Grid Weld - LH (3,000 lb wheel lift)	1				
	3484000017^	Grid Weld - LH (4,000 lb wheel lift)					
3	3484000050+	Grid Weld - RH (3,000 lb wheel lift)	1				
	3484000016>	Grid Weld - RH (4,000 lb wheel lift)					
4	4259000002*^	Pivot Casting, LH	1				
5	4259000001+>	Pivot Casting, RH	1				
6	4691000354~	Pin	2				
7	4691000357~	Pin	2				
8	7754000037~	Retaining Ring	2				
9	3551000036^>	T-Handle	2				
10	4691000186~	Pin	2				
11	7843000006~	Spring	2				
12	4763000184~	Rod	2				
13	4254000005~	Cap	2				
14	7786000006~	Screw	2				
15	7843000016~	Spring	2				
16	4691000183~	Pin	2				
17	4691000447	Pivot Pin (3,000 lb wheel lift)	1				
	4691000427	Pivot Pin (4,000 lb wheel lift)					
18	4949000047	Washer	2				
19	7754000024	Retaining Ring	1				
20	7440030000~	Grease Fitting	6				

\* also available in Grid Assembly, LH, P/N 3484000053

+ also available in Grid Assembly, RH, P/N 3484000052

~ also available in Grid Assembly, P/N's 3484000046, 3484000047, 3484000052 & 3484000053

^ also available in Grid Assembly, LH, P/N 3484000047

> also available in Grid Assembly, RH, P/N 3484000046



# MANUAL T37 PIVOTING WHEEL LIFT GRID

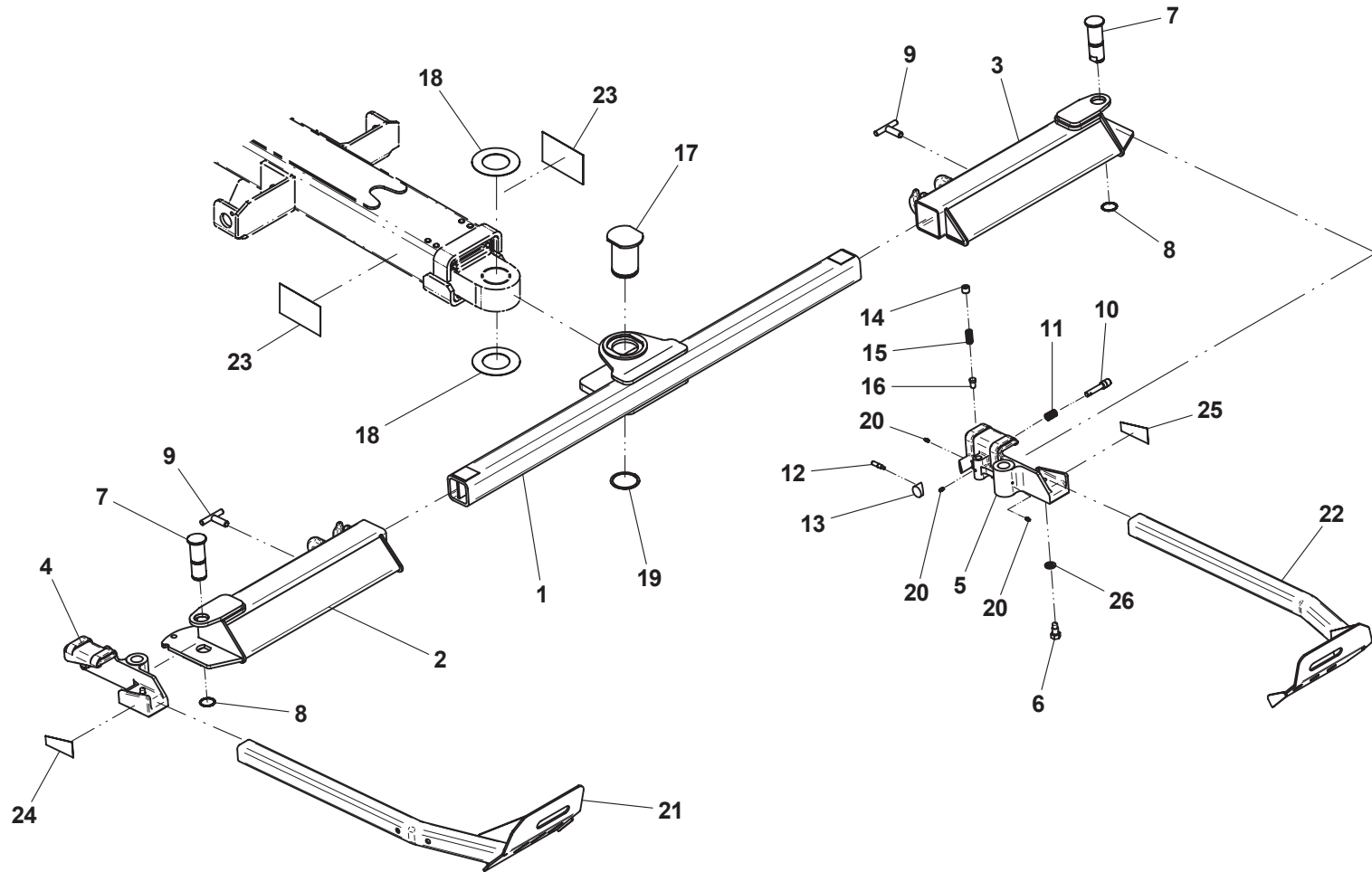

3,000 lb wheel lift grid shown

**HYDRAULIC REAR DOCK STABILIZER**

ITEM	PART NO.	DESCRIPTION	QTY
1	3849000032	Stabilizer Weld	1
2	3320000131	Cylinder Assembly	2
3	3691000184	Pin Weld	4
4	7115160950	Capscrew, 0.38"-16NC x 1.12"	4
5	7660162601	Locknut, 0.38"-16NC	4
6	7082000019*	Bearing	4

\* included in Stabilizer Weld, P/N 3849000032

# HYDRAULIC REAR DOCK STABILIZER

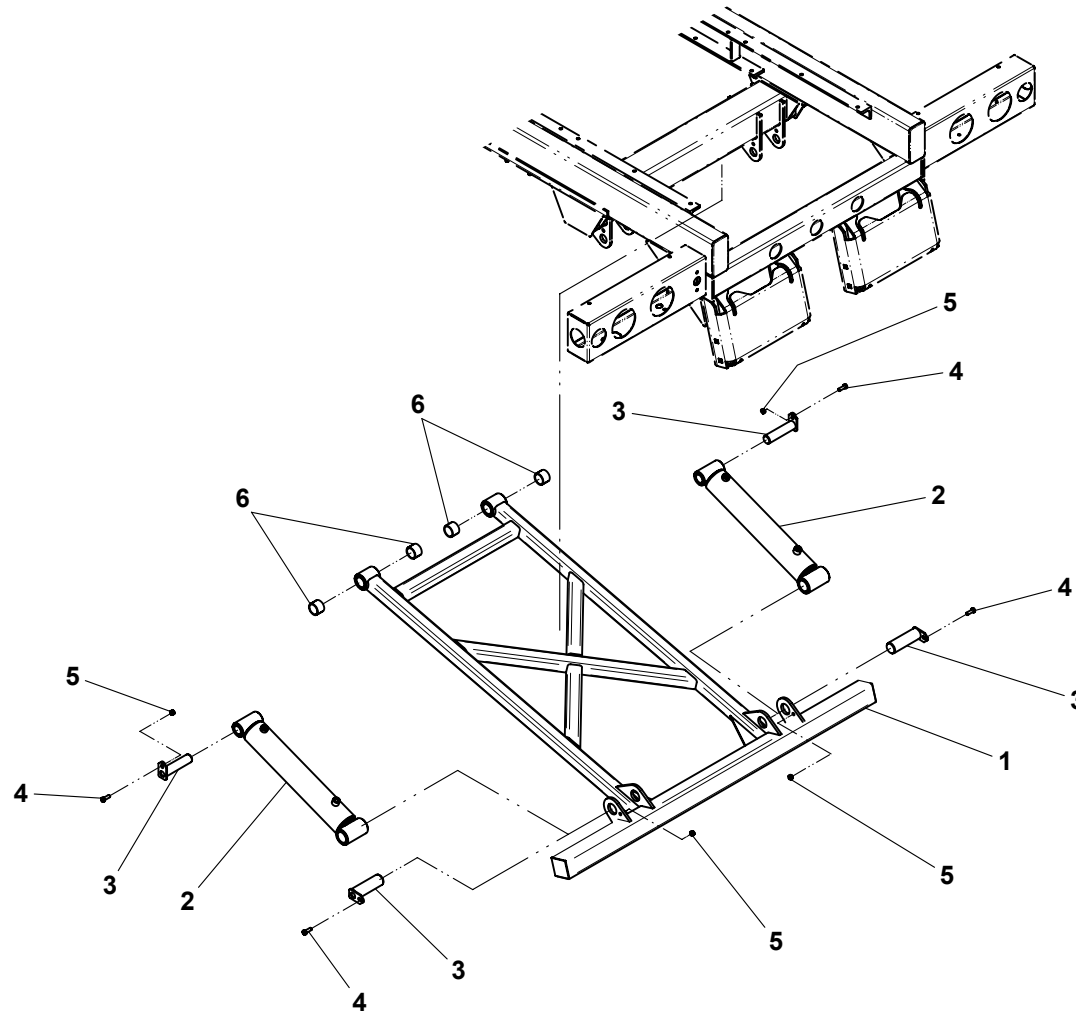

**HYDRAULIC REAR DOCK STABILIZER WITH REESE HITCH RECEIVER**

ITEM	PART NO.	DESCRIPTION	QTY
1	3849000034	Stabilizer Weld w/ Reese Hitch Receiver	1
2	3320000132	Cylinder Assembly	2
3	3691000184	Pin Weld	4
4	7115160950	Capscrew, 0.38"-16NC x 1.12"	4
5	7660162601	Locknut, 0.38"-16NC	4
6	7082000019*	Bearing	4
7	7291000003	4-Way Receptacle	1
8	7796000048	Gasket	1
9	7114140528	Screw, 0.25"-20NC x .63"	2
10	7660142601	Locknut, 0.25"-20NC	2
11	7913000006	Tube Reducer	1
12	7691000033	Hitch Pin	1

\* included in Stabilizer Weld, P/N 3849000034

# HYDRAULIC REAR DOCK STABILIZER WITH REESE HITCH RECEIVER

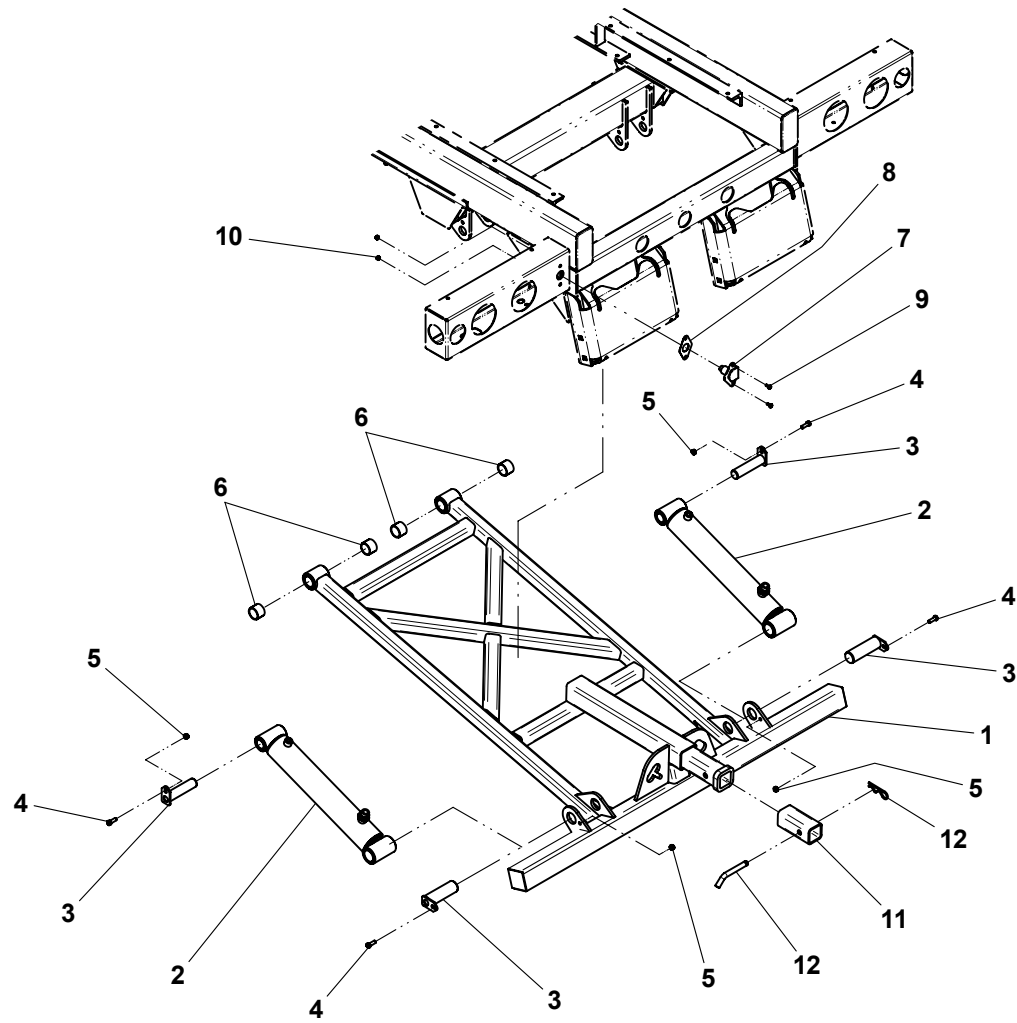

**HYDRAULIC REAR DOCK STABILIZER WITH MANUAL EXTEND PINTLE HITCH MOUNTING PLATE**

ITEM	PART NO.	DESCRIPTION	QTY
1	3849000033	Stabilizer Weld w/ Manual Pintle Plate	1
2	3320000132	Cylinder Assembly	2
3	3691000184	Pin Weld	4
4	7115160950	Capscrew, 0.38"-16NC x 1.12"	4
5	7660162601	Locknut, 0.38"-16NC	4
6	3170000203	Inner Boom Weld	1
7	3691000064	Pin Weld	1
8	7691000001	Hair Pin	1
9	7082000019*	Bearing	4
10	7291000003	4-Way Receptacle	1
11	7796000048	Gasket	1
12	7114140528	Screw, 0.25"-20NC x 0.63"	2
13	7660142601	Locknut, 0.25"-20NC	2

\* included in Stabilizer Weld, P/N 3849000033

# HYDRAULIC REAR DOCK STABILIZER WITH MANUAL EXTEND PINTLE HITCH MOUNTING PLATE

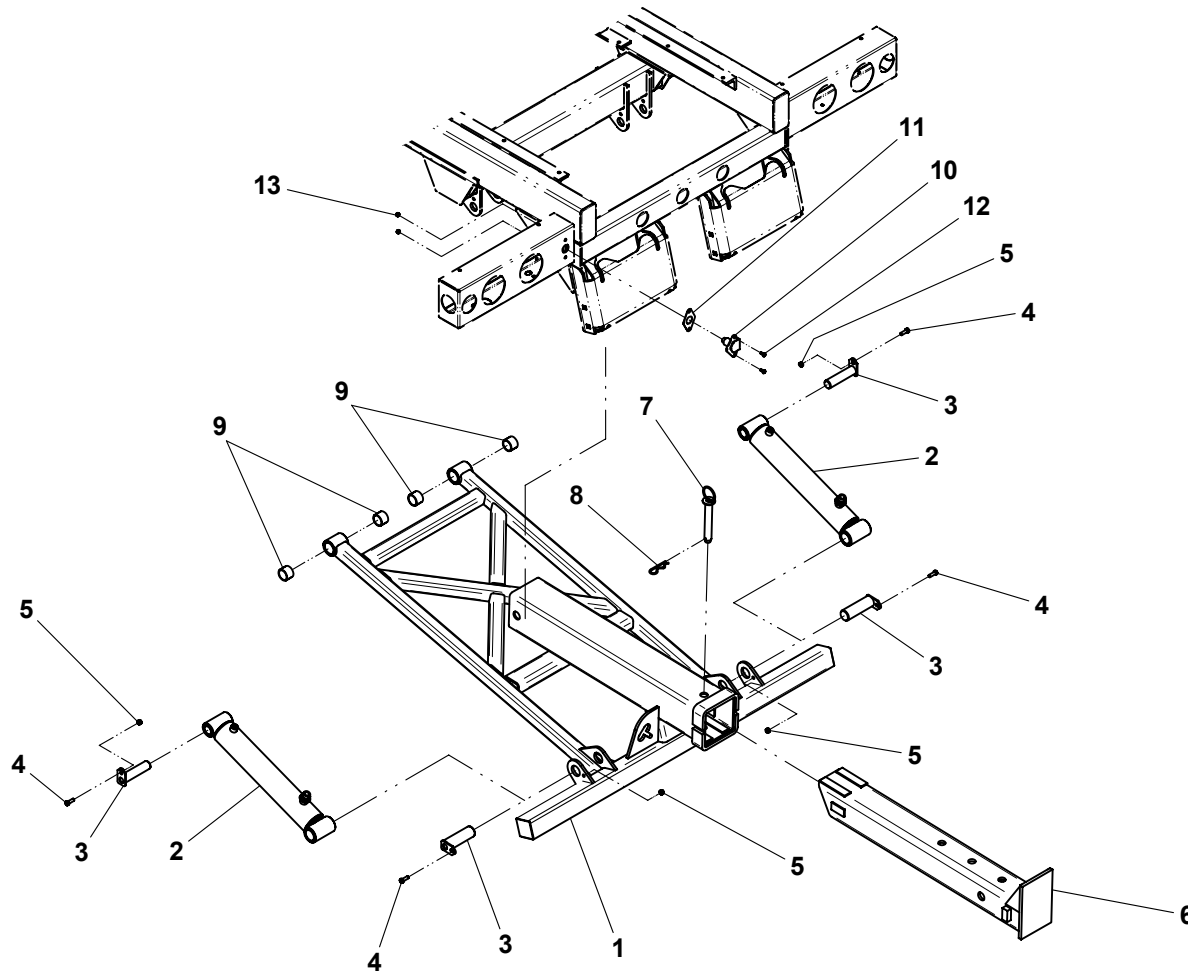

**HYDRAULIC REAR DOCK STABILIZER WITH HYDRAULIC EXTEND PINTLE HITCH MTG PLATE**

ITEM	PART NO.	DESCRIPTION	QTY
1	3849000033	Stabilizer Weld w/ Hyd Pintle Plate	1
2	3320000132	Cylinder Assembly	2
3	3691000184	Pin Weld	4
4	7115160950	Capscrew, 0.38"-16NC x 1.12"	4
5	7660162601	Locknut, 0.38"-16NC	4
6	3170000203	Inner Boom Weld	1
7	3691000064	Pin Weld	1
8	7691000001	Hair Pin	1
9	3320000117	Cylinder Assembly	1
10	4691000430	Pin	1
11	4691000429	Pin	1
12	7754000006	Retaining Ring	4
13	7082000019*	Bearing	4
14	7291000003	4-Way Receptacle	1
15	7796000048	Gasket	1
16	7114140528	Screw, 0.25"-20NC x 0.63"	2
17	7660142601	Locknut, 0.25"-20NC	2

\* included in Stabilizer Weld, P/N 3849000033



# HYDRAULIC REAR DOCK STABILIZER WITH HYDRAULIC EXTEND PINTLE HITCH MTG PLATE

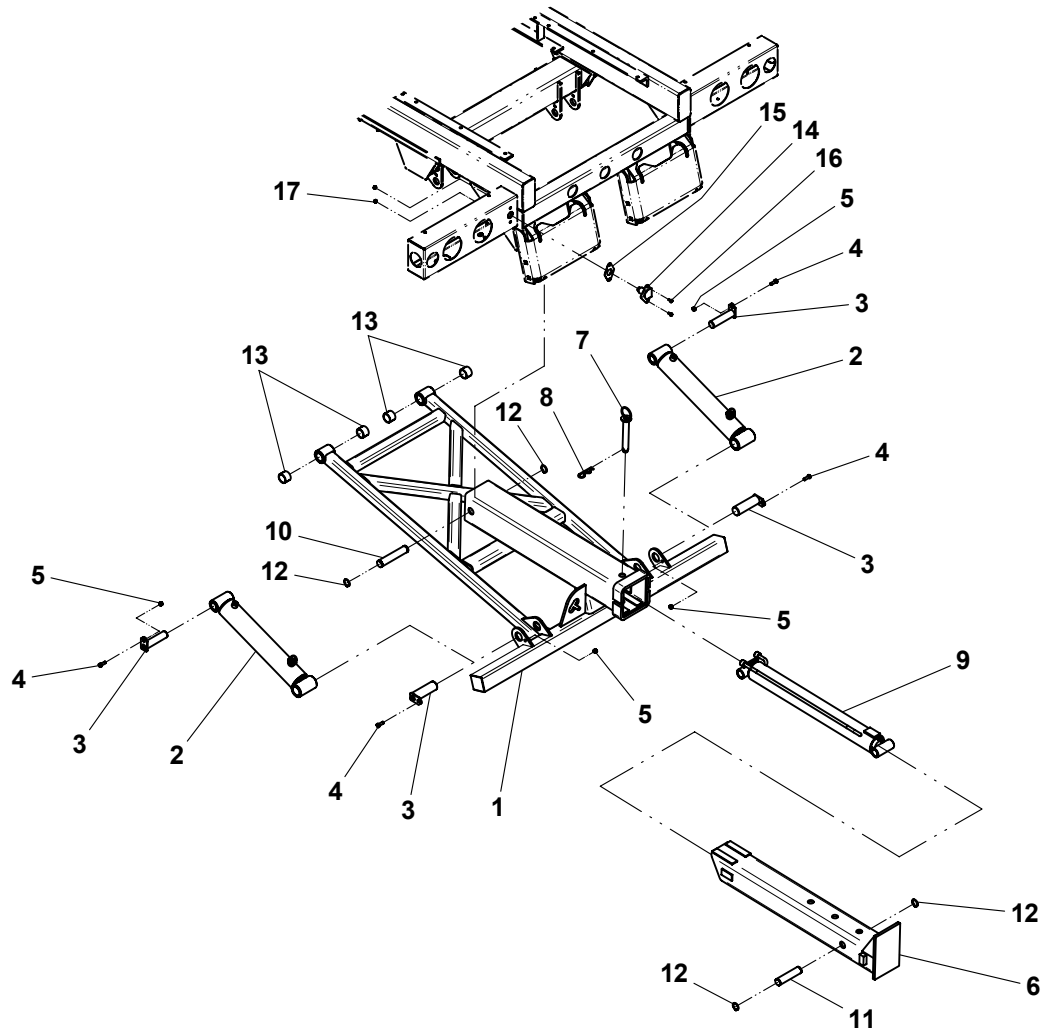

**HYDRAULIC REAR DOCK STABILIZER WITH HYDRAULIC EXTEND WHEEL LIFT**

ITEM	PART NO.	DESCRIPTION	QTY
1	3849000035	Stabilizer Weld	1
2	3170000304	Inner Boom Weld	1
3	3320000115	Cylinder Assembly	1
4	4691000296	Pin	1
5	4691000268	Pin	1
6	7754000006	Retaining Ring	4
7	7082000021*	Bushing	1
8	4679000046	Wear Pad	1
9	4017000739	Angle	2
10	7118140418	Capscrew, 0.25"-20NC x 0.50"	4
11	7950100151	Washer, 0.19" ID	4
12	4679000211	Wear Pad	1
13	3073000010	Stabilizer Base Weld	2
14	7691000071	Hitch Pin	2
15	7082000019+	Bearing	4
16	3320000132	Cylinder assembly	2
17	3691000184	Pin Weld	4
18	7115160950	Capscrew, 0.38"-16NC x 1.12"	4
19	7660162601	Locknut, 0.38"-16NC	4
20	7291000003	4-Way Receptacle	1
21	7796000048	Gasket	1
22	7114140528	Screw, 0.25"-20NC x 0.63"	2
23	7660142601	Locknut, 0.25"-20NC	2

\* included in Inner Boom Weld, P/N 3170000304

+ included in Stabilizer Weld, P/N 3849000035

# HYDRAULIC REAR DOCK STABILIZER WITH HYDRAULIC EXTEND WHEEL LIFT

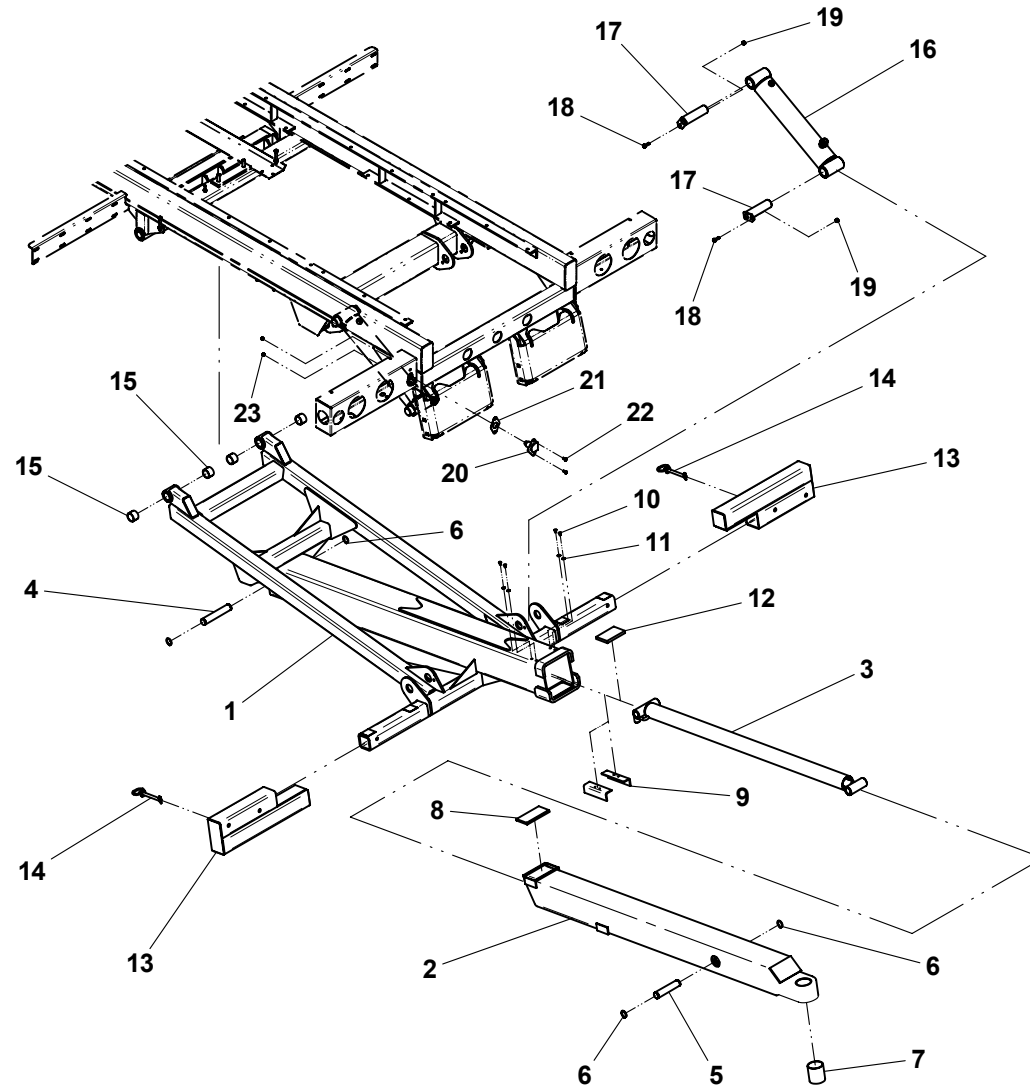

**BALL HITCH MOUNTING PLATE - HYDRAULIC EXTEND**

ITEM	PART NO.	DESCRIPTION	QTY
1	3170000314	Outer Boom Weld	1
2	3911000062	Inner Boom Weld	1
3	3320000116	Cylinder Assembly	1
4	4691000430	Pin	1
5	4691000429	Pin	1
6	7754000006	Retaining Ring	4
7	3691000073	Pin Weld	1
8	3691000064	Pin Weld	1
9	7115160950	Capscrew, 0.38"-16NC x 1.12"	1
10	7660162601	Locknut, 0.38"-16NC	1
11	3691000097	Pin Weld	1
12	7691000001	Hair Pin	2
13	7082000016*	Bushing	2
14	7291000003	4-Way Receptacle	1
15	7796000048	Gasket	1
16	7114140528	Screw, 0.25"-20NC x 0.63"	2
17	7660142601	Locknut, 0.25"-20NC	2
18	4330000002	Reflective Tape	2

\* included in Outer Boom Weld, P/N 3170000314

# BALL HITCH MOUNTING PLATE - HYDRAULIC EXTEND

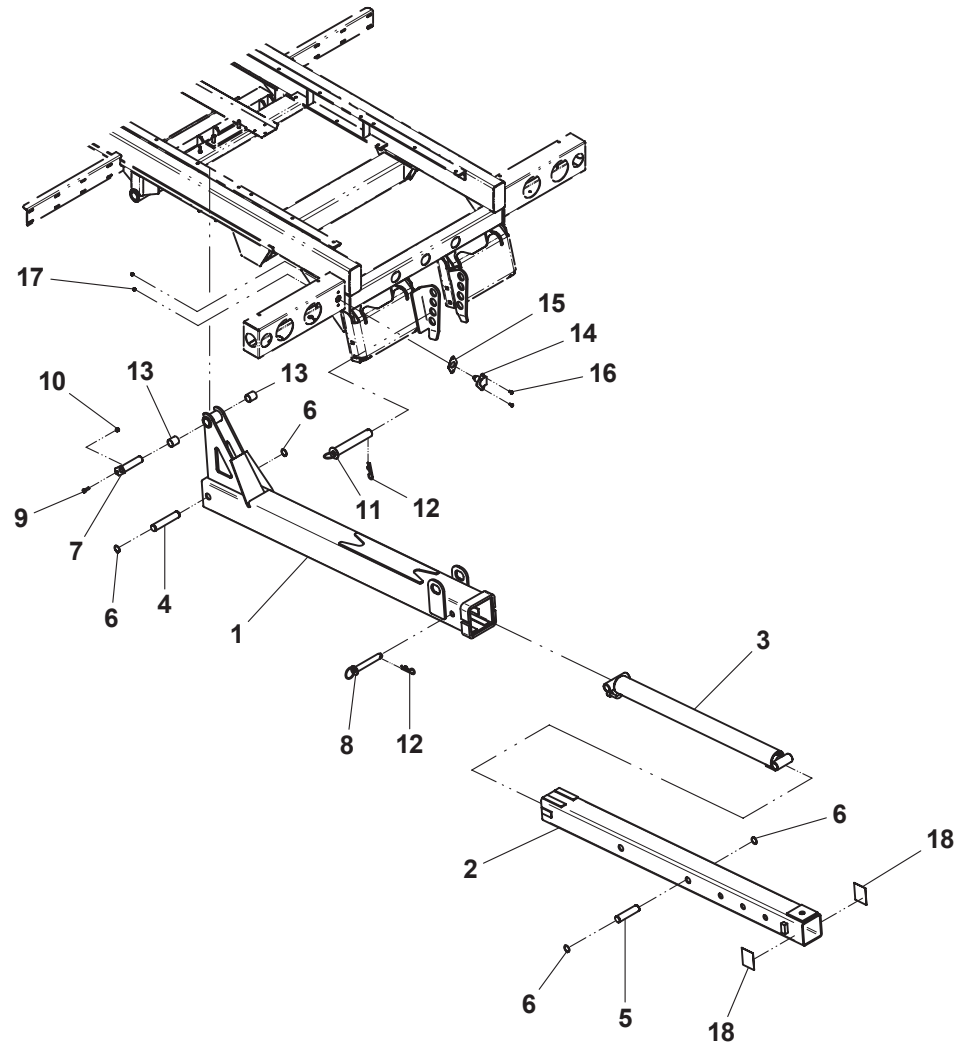

**BALL HITCH MOUNTING PLATE - MANUAL EXTEND**

ITEM	PART NO.	DESCRIPTION	QTY
1	3170000314	Outer Boom Weld	1
2	3911000062	Inner Boom Weld	1
3	3691000064	Pin Weld	1
4	7691000001	Hair Pin	2
5	3691000073	Pin Weld	1
6	7115160950	Capscrew, 0.38"-16NC x 1.12"	1
7	7660162601	Locknut, 0.38"-16NC	1
8	3691000097	Pin Weld	1
9	7082000016*	Bushing	2
10	7291000003	4-Way Receptacle	1
11	7796000048	Gasket	1
12	7114140528	Screw, 0.25"-20NC x 0.63"	2
13	7660142601	Locknut, 0.25"-20NC	2
14	4330000002	Reflective Tape	2

\* included in Outer Boom Weld, P/N 3170000314

# BALL HITCH MOUNTING PLATE - MANUAL EXTEND

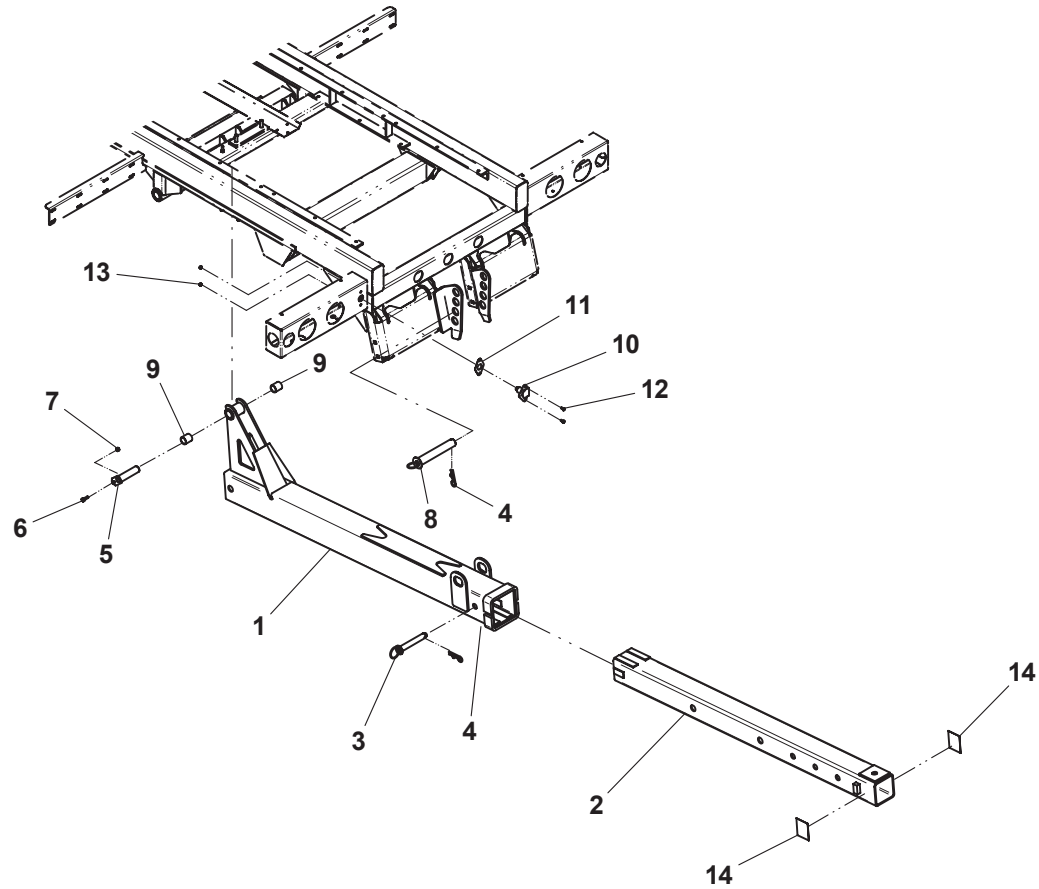

**PINTLE HITCH MOUNTING PLATE - HYDRAULIC EXTEND**

ITEM	PART NO.	DESCRIPTION	QTY
1	3170000314	Outer Boom Weld	1
2	3170000208	Inner Boom Weld	1
3	3320000116	Cylinder Assembly	1
4	4691000430	Pin	1
5	4691000429	Pin	1
6	7754000006	Retaining Ring	4
7	3691000073	Pin Weld	1
8	3691000064	Pin Weld	1
9	7115160950	Capscrew, 0.38"-16NC x 1.12"	1
10	7660162601	Locknut, 0.38"-16NC	1
11	3691000097	Pin Weld	1
12	7691000001	Hair Pin	2
13	7082000016*	Bushing	2
14	7291000003	4-Way Receptacle	1
15	7796000048	Gasket	1
16	7114140528	Screw, 0.25"-20NC x 0.63"	2
17	7660142601	Locknut, 0.25"-20NC	2
18	4330000002	Reflective Tape	1
19	4330000645	Reflective Tape LH	1
20	4330000646	Reflective Tape RH	1

\* included in Outer Boom Weld, P/N 3170000314



# PINTLE HITCH MOUNTING PLATE - HYDRAULIC EXTEND

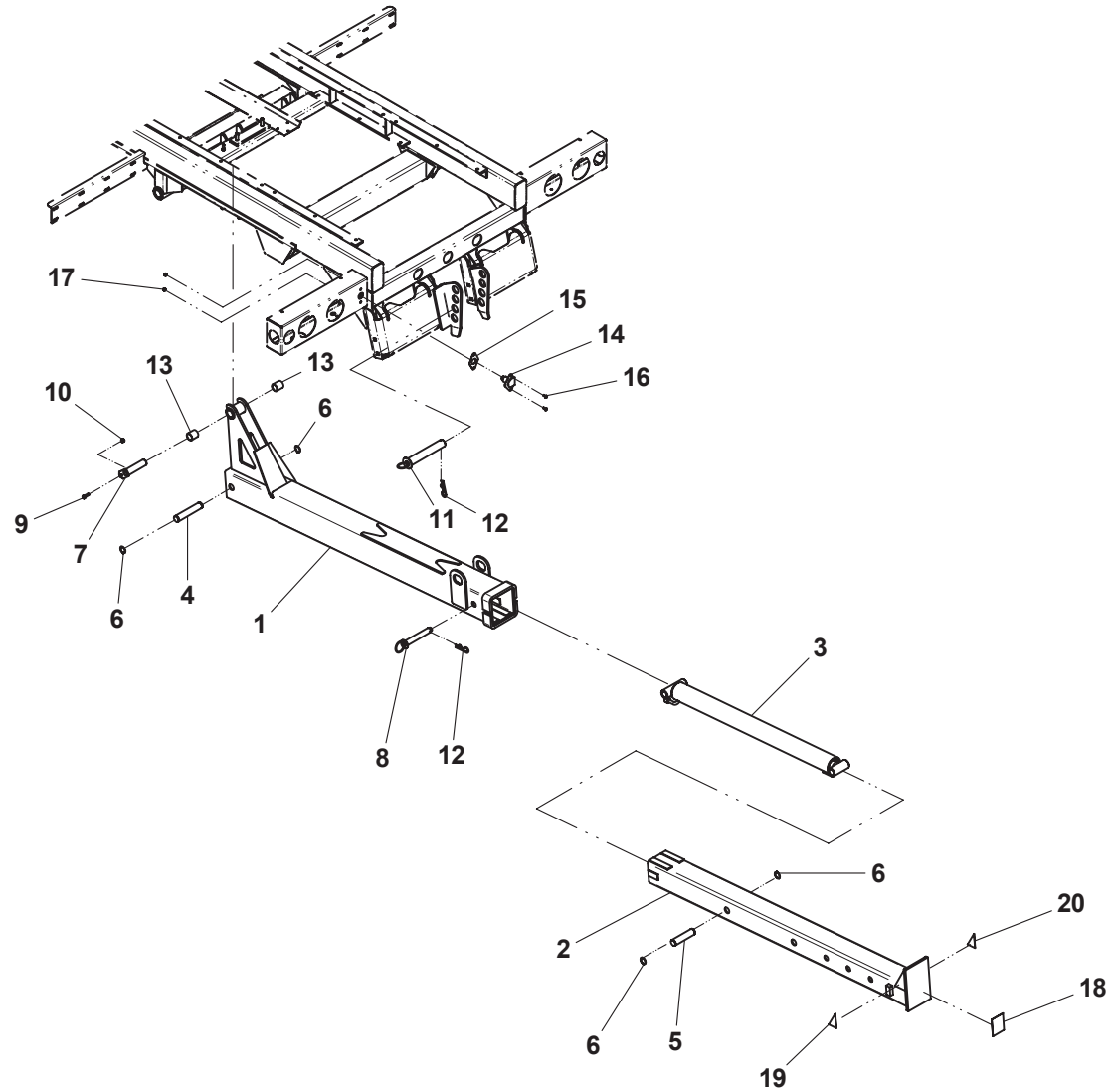

**PINTLE HITCH MOUNTING PLATE - MANUAL EXTEND**

ITEM	PART NO.	DESCRIPTION	QTY
1	3170000314	Outer Boom Weld	1
2	3170000208	Inner Boom Weld	1
3	3691000064	Pin Weld	1
4	7691000001	Hair Pin	2
5	3691000073	Pin Weld	1
6	7115160950	Capscrew, 0.38"-16NC x 1.12"	1
7	7660162601	Locknut, 0.38"-16NC	1
8	3691000097	Pin Weld	1
9	7082000016*	Bushing	2
10	7291000003	4-Way Receptacle	1
11	7796000048	Gasket	1
12	7114140528	Screw, 0.25"-20NC x 0.63"	2
13	7660142601	Locknut, 0.25"-20NC	2
14	4330000002	Reflective Tape	1
15	4330000645	Reflective Tape LH	1
16	4330000646	Reflective Tape RH	1

\* included in Outer Boom Weld, P/N 3170000314

# PINTLE HITCH MOUNTING PLATE - MANUAL EXTEND

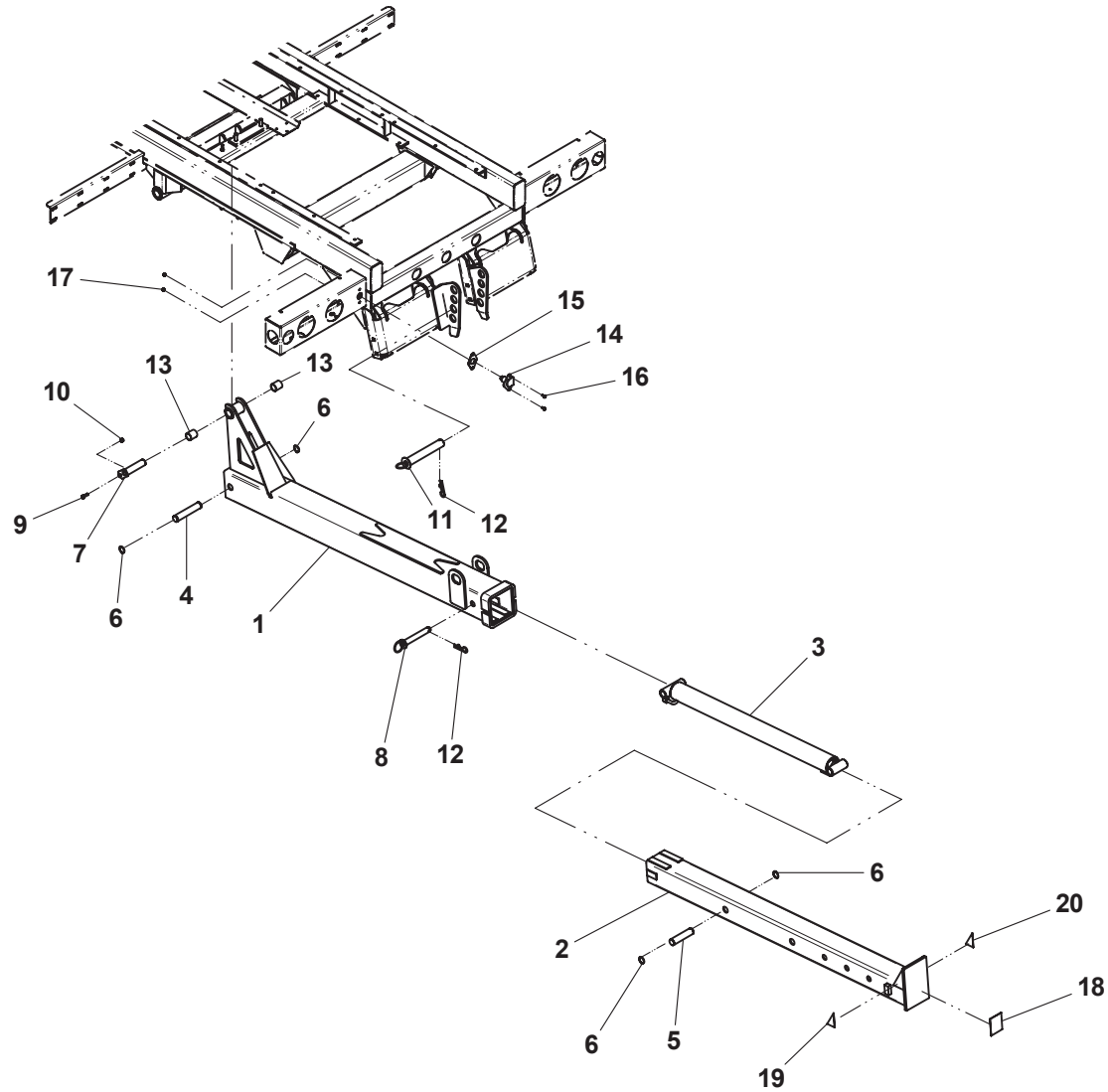

**TOWBAR - IRL**

ITEM	PART NO.	DESCRIPTION	QTY
1	3170000313	Outer Boom Weld	1
2	3170000078	Inner Boom Weld	1
3	3320000116	Cylinder Assembly	1
4	4691000430	Pin	1
5	4691000429	Pin	1
6	7754000006	Retaining Ring	4
7	7440030000	Grease Fitting	1
8	3320000114	Cylinder Assembly	2
9	3691000164	Pin Weld	2
10	7115160950	Capscrew, 0.38"-16NC x 1.12"	5
11	7660162601	Locknut, 0.38"-16NC	5
12	3691000073	Pin Weld	3
13	3020000106	Arm Weld	2
14	7082000019*	Bushing	4
15	7082000018*	Bushing	4
16	7082000016+	Bushing	2
17	3556000026	Tow Hitch Weld (rubber tubes)	1
	3556000028	Tow Hitch Weld (keyslots)	
18	4120000008	Capscrew, 1.50"-12NF x 6.38"	1
19	7912000011	Tube Rubber	2
20	7291000003	4-Way Receptacle	1
21	7796000048	Gasket	1
22	7114140528	Screw, 0.25"-20NC x 0.63"	2
23	7660142601	Locknut, .025"-20NC	2
24	7330000419	Reflective Tape	2
25	4330000001	Reflective Tape	1

\* included in Arm Weld, P/N 3020000106

+ included in Outer Boom Weld, P/N 3170000313

# TOWBAR - IRL

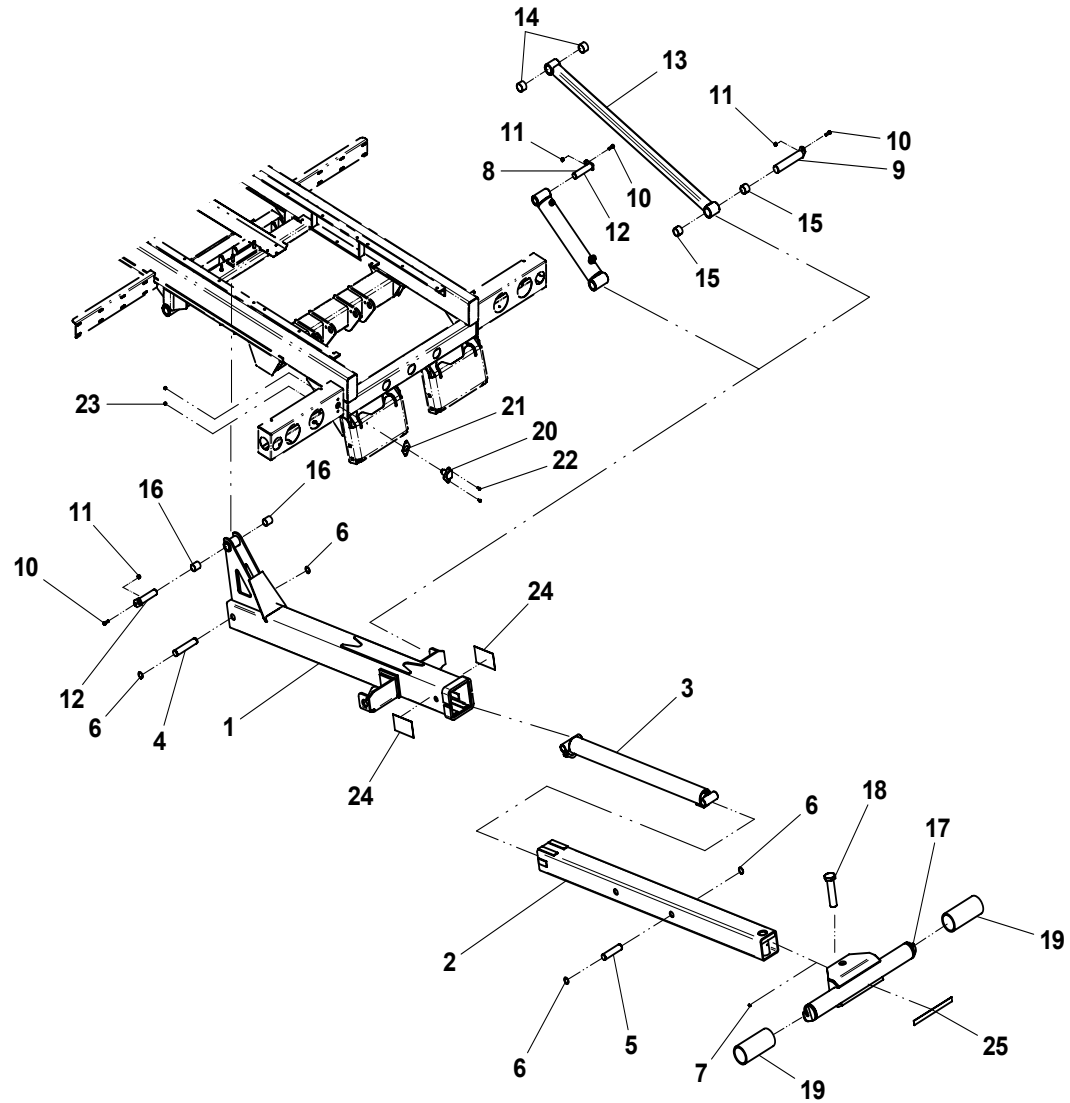

IRL towbar with rubber tubes shown

**TOWBAR - HYDRAULIC EXTEND**

ITEM	PART NO.	DESCRIPTION	QTY
1	3170000314	Outer Boom Weld	1
2	3170000048	Inner Boom Weld	1
3	3320000116	Cylinder Assembly	1
4	4691000430	Pin	1
5	4691000429	Pin	1
6	7754000006	Retaining Ring	4
7	7440030000	Grease Fitting	1
8	3691000073	Pin Weld	1
9	7115160950	Capscrew, 0.38"-16NC x 1.12"	1
10	7660162601	Locknut, 0.38"-16NC	1
11	3691000097	Pin Weld	1
12	7691000001	Hair Pin	1
13	7082000016*	Bushing	2
14	3556000023	Tow Hitch Weld	1
15	4120000008	Capscrew, 1.50"-12NF x 6.38"	1
16	7912000011	Tube Rubber	2
17	7291000003	4-Way Receptacle	1
18	7796000048	Gasket	1
19	7114140528	Screw, 0.25"-20NC x 0.63"	2
20	7660142601	Locknut, 0.25"-20NC	2
21	7330000419	Reflective Tape	2
22	4330000001	Reflective Tape	1

\* included in Outer Boom Weld, P/N 3170000314

# TOWBAR - HYDRAULIC EXTEND

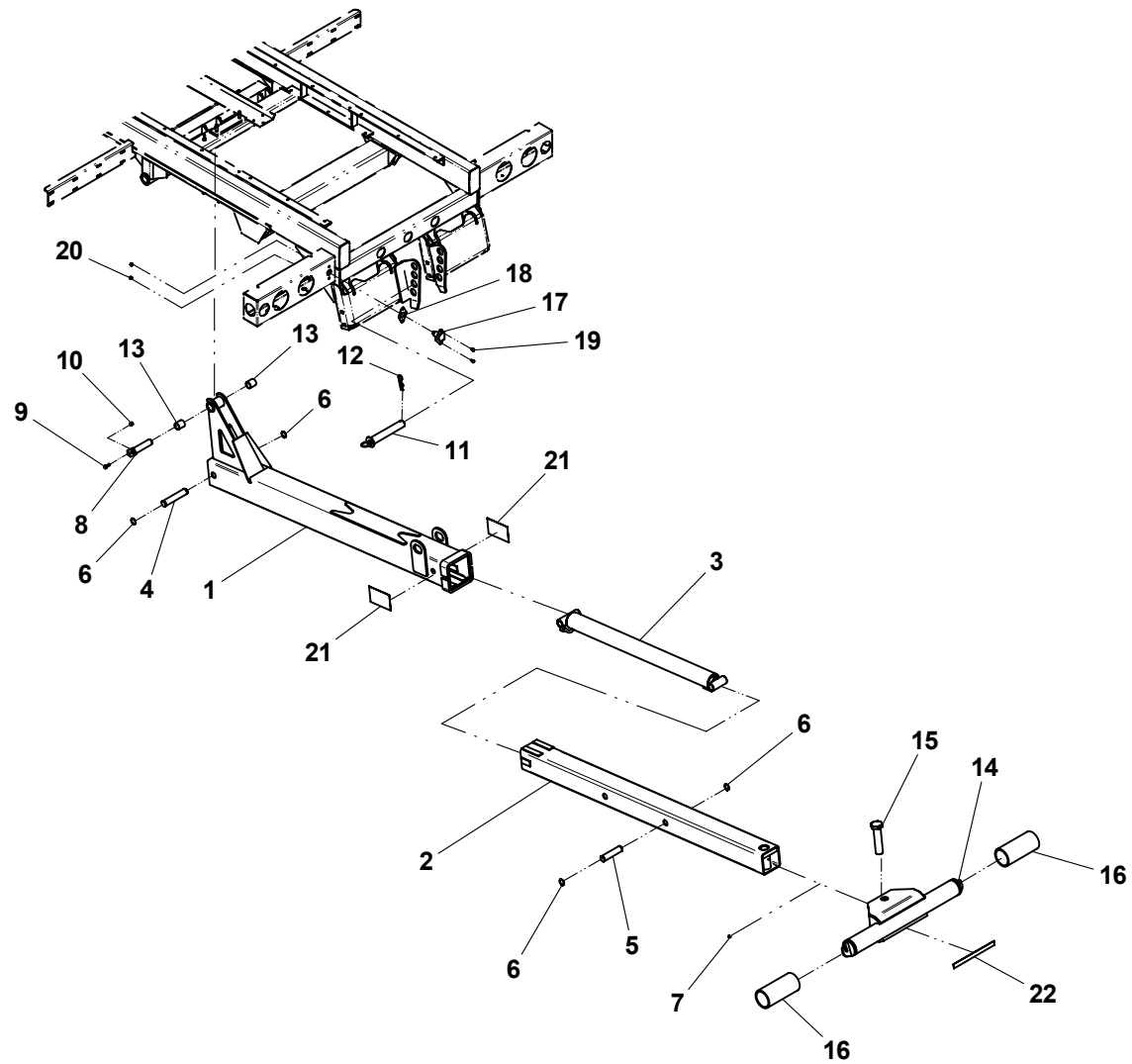

**ROLL CYLINDER ASSEMBLY - P/N 3320000121 & P/N 3320000128**

ITEM	PART NO.	DESCRIPTION	QTY
1	3071000116	Barrel Weld (24' & 26' deck)	1
	3071000126	Barrel Weld (28' deck)	
2	4763000093	Rod (24' & 26' deck)	1
	4763000242	Rod (28' deck)	
3	4698000009*	Piston	1
4	7796000013* #	Wear Ring	2
5	7796000064* #	Piston Locking "T" Seal	1
6	7755226609* #	Back-Up Ring	2
7	7755226000* #	"O" Ring	1
8	4553000010^	Head	1
9	7755338000^ #	"O" Ring	1
10	7755338609^ #	Back-Up Ring	1
11	7754000012^ #	Wear Ring	1
12	7796000025^ #	Rod Seal	1
13	7796000011^ #	Rod Wiper Seal	1
14	7754000016 #	Retaining Ring	1
15	7754000027 #	Retaining Ring	1
16	7661000035	Locknut	2

\* included in Piston Assembly, P/N 3698000004

^ included in Head Assembly, P/N 3553000014

# available only in Service Kit #7577250025



# ROLL CYLINDER ASSEMBLY - P/N 3320000121 & P/N 3320000128

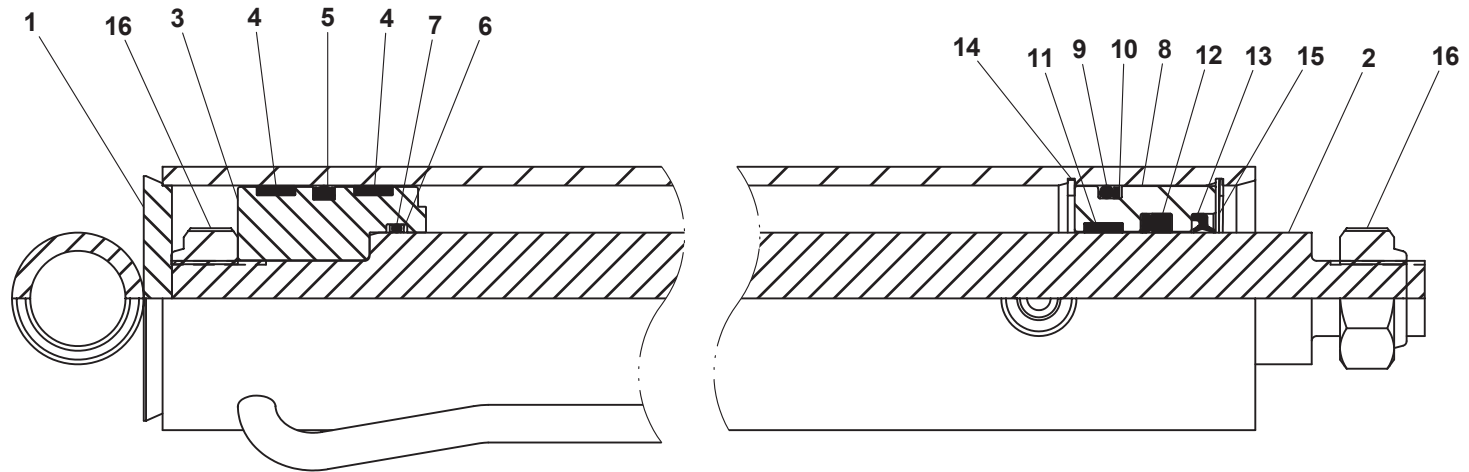

**TILT CYLINDER ASSEMBLY - P/N 3320000129**

ITEM	PART NO.	DESCRIPTION	QTY
1	3071000122	Barrel Weld	1
2	3763000132	Rod Weld	1
3	4698000009*	Piston	1
4	7754000013* #	Wear Ring	2
5	7796000064* #	Piston Locking "T" Seal	1
6	7755226609* #	Back-Up Ring	2
7	7755226000* #	"O" Ring	1
8	4553000010^	Head	1
9	7755338000^ #	"O" Ring	1
10	7755338609^ #	Back-Up Ring	1
11	7754000012^ #	Wear Ring	1
12	7796000025^ #	Rod Seal	1
13	7796000011^ #	Rod Wiper Seal	1
14	7754000016#	Retaining Ring	1
15	7754000027#	Retaining Ring	1
16	7661000035	Locknut	1
17	7082000018	Bearing	4

\* included in Piston Assembly, P/N 3698000004

^ included Head Assembly, P/N 3553000014

# available only in Service Kit #7577250025

# TILT CYLINDER ASSEMBLY - P/N 3320000129

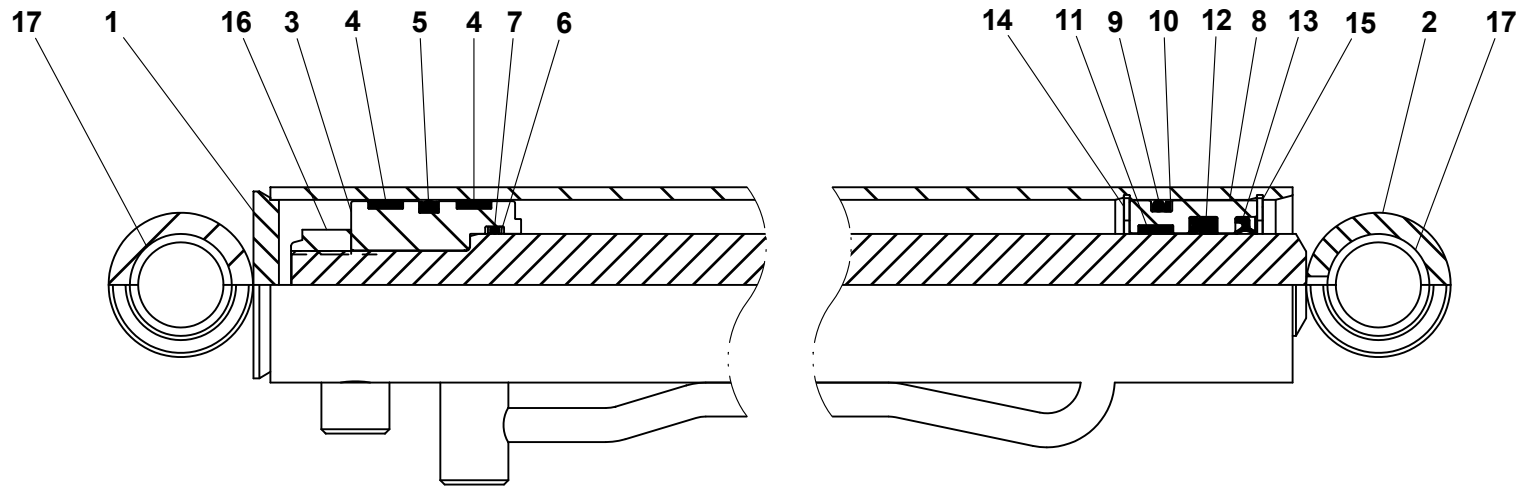

**WHEEL LIFT EXTEND CYLINDER ASSEMBLY - P/N 3320000115**

ITEM	PART NO.	DESCRIPTION	QTY
1	3071000106	Barrel Weld	1
2	3763000119	Rod Weld	1
3	4698000015*	Piston	1
4	7754000053* #	Wear Ring	2
5	7796000067* #	Piston Locking "T" Seal	1
6	7755222609* #	Back-Up Ring	2
7	7755222000* #	"O" Ring	1
8	4553000016^	Head	1
9	7755330000^ #	"O" Ring	1
10	7755330609^ #	Back-Up Ring	1
11	7754000054^ #	Wear Ring	1
12	7796000045^ #	Rod Seal	1
13	7796000046^ #	Rod Wiper Seal	1
14	7754000051#	Retaining Ring	2
15	7661000034	Locknut	1

\* included in Piston Assembly, P/N 3698000006

^ included in Head Assembly, P/N 3553000016

# available only in Service Kit #7577250206

**WHEEL LIFT EXTEND CYLINDER ASSEMBLY - P/N 3320000115**

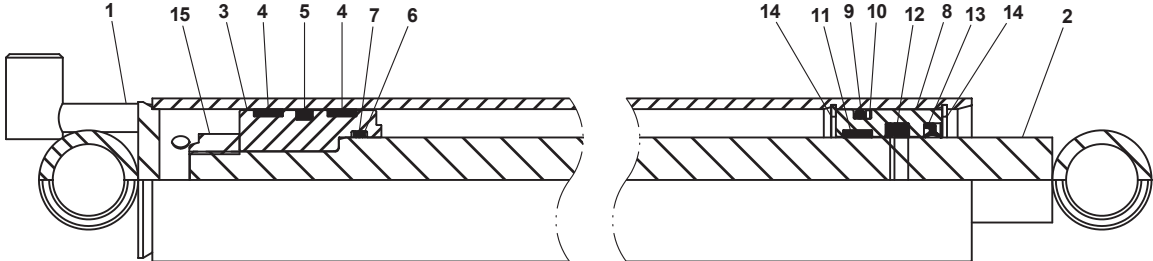

**IRL CYLINDER ASSEMBLY - P/N 3320000114, P/N 3320000123 & P/N 3320000124**

ITEM	PART NO.	DESCRIPTION	QTY
1	3071000105	Barrel Weld (P/N 3320000114)	1
	3071000118	Barrel Weld (P/N 3320000123)	
	3071000119	Barrel Weld (P/N 3320000124)	
2	3763000118	Rod Weld (P/N 3320000114)	1
	3763000128	Rod Weld (P/N 3320000123)	
	3763000129	Rod Weld (P/N 3320000124)	
3	4698000007*	Piston	1
4	7754000003* #	Wear Ring	2
5	7796000063* #	Piston Locking "T" Seal	1
6	7755224609* #	Back-Up Ring	2
7	7755224000* #	"O" Ring	1
8	4553000008^	Head	1
9	7755334000^ #	"O" Ring	1
10	7755334609^ #	Back-Up Ring	1
11	7754000004^ #	Wear Ring	1
12	7796000024^ #	Rod Seal	1
13	7796000008^ #	Rod Wiper Seal	1
14	7754000002 #	Retaining Ring	1
15	7754000026 #	Retaining Ring	1
16	7661000034	Locknut	1
17	7082000016	Bearing	2
18	7082000018	Bearing	2

\* included in Piston Assembly, P/N 3698000001

^ included in Head Assembly, P/N 3553000011

# available only in Service Kit #7577250024

**IRL CYLINDER ASSEMBLY - P/N 3320000114, P/N 3320000123 & P/N 3320000124**

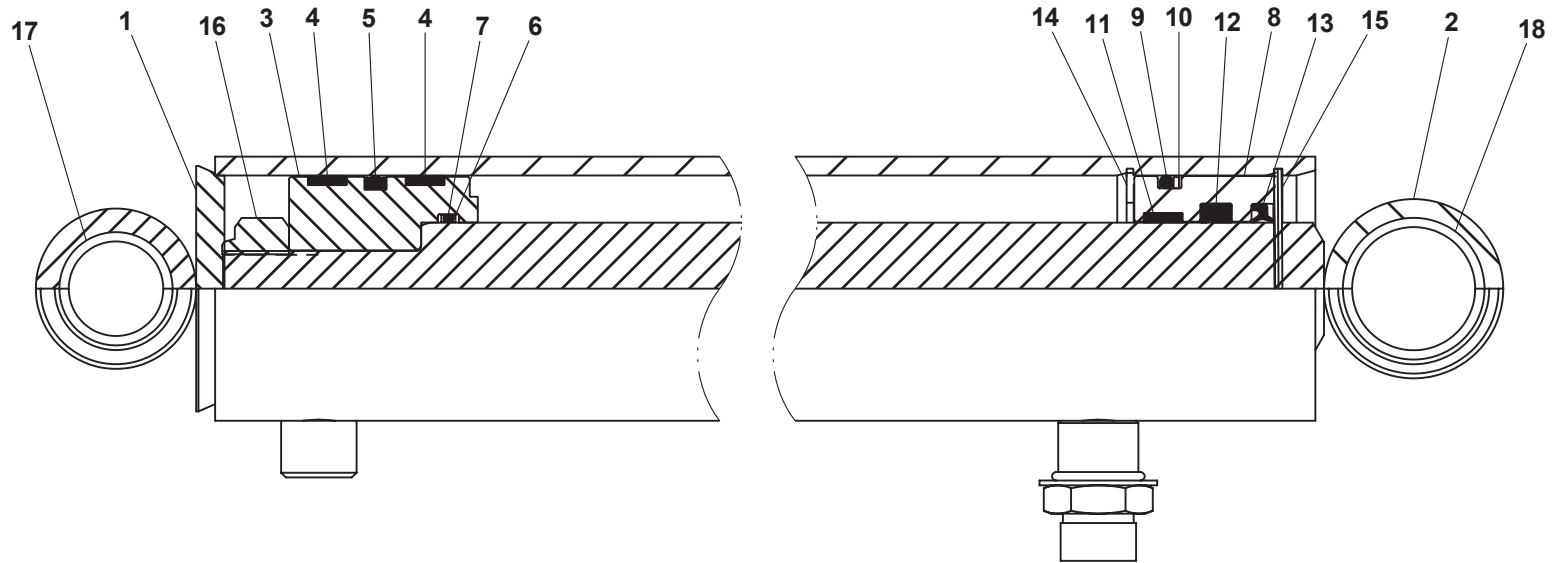

**STABILIZER CYLINDER ASSEMBLY - P/N 3320000131**

ITEM	PART NO.	DESCRIPTION	QTY
1	3071000128	Barrel Weld	1
2	3763000133	Rod Weld	1
3	4698000009*	Piston	1
4	7754000013* #	Wear Ring	2
5	7796000064* #	Piston Locking "T" Seal	1
6	7755226609* #	Back-Up Ring	2
7	7755226000* #	"O" Ring	1
8	4553000010^	Head	1
9	7755338000^ #	"O" Ring	1
10	7755338609^ #	Back-Up Ring	1
11	7754000012^ #	Wear Ring	1
12	7796000025^ #	Rod Seal	1
13	7796000011^ #	Rod Wiper Seal	1
14	7754000016 #	Retaining Ring	1
15	7754000027 #	Retaining Ring	1
16	7661000035	Locknut	1
17	7082000018	Bearing	4

\* included in Piston Assembly, P/N 3698000001

^ included in Head Assembly, P/N 3553000011

# available only in Service Kit #7577250024



# STABILIZER CYLINDER ASSEMBLY - P/N 3320000131

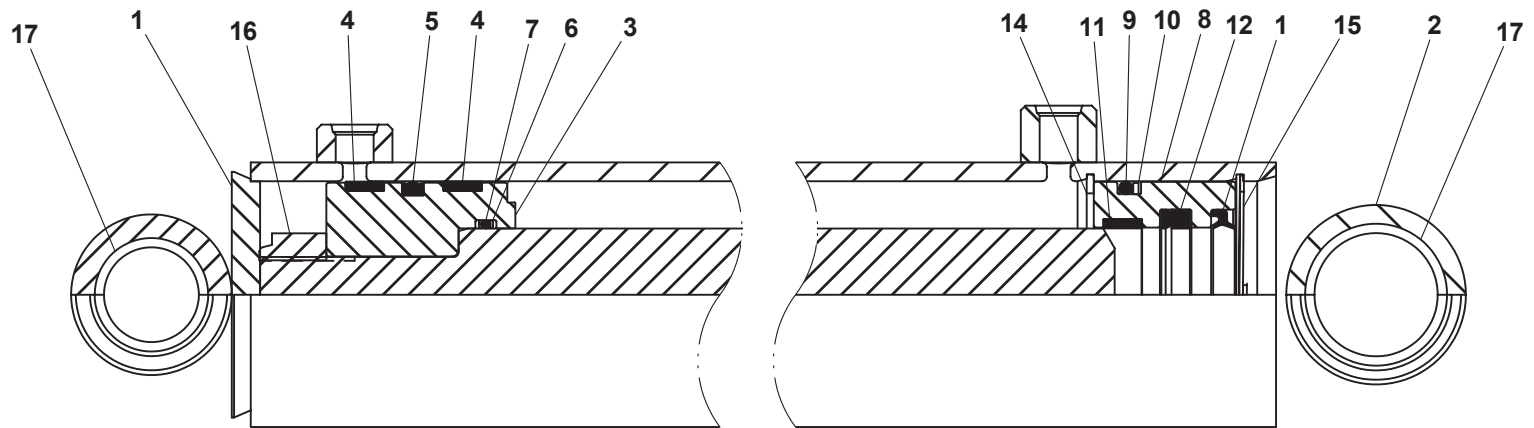

**TOW OPTION HYDRAULIC EXTEND CYLINDER ASSEMBLY - P/N 3320000116 & P/N 3320000117**

ITEM	PART NO.	DESCRIPTION	QTY
1	3071000107	Barrel Weld (P/N 3320000116)	1
	3071000108	Barrel Weld (P/N 3320000117)	
2	3763000120	Rod Weld (P/N 3320000116)	1
	3763000121	Rod Weld (P/N 3320000117)	
3	4698000007*	Piston	1
4	7754000003* #	Wear Ring	2
5	7796000063* #	Piston Locking "T" Seal	1
6	7755224609* #	Back-Up Ring	2
7	7755224000* #	"O" Ring	1
8	4553000008^	Head	1
9	7755334000^ #	"O" Ring	1
10	7755334609^ #	Back-Up Ring	1
11	7754000004^ #	Wear Ring	1
12	7796000024^ #	Rod Seal	1
13	7796000008^ #	Rod Wiper Seal	1
14	7754000002 #	Retaining Ring	1
15	7754000026 #	Retaining Ring	1
16	7661000034	Locknut	1

\* included in Piston Assembly, P/N 3698000001

^ included in Head Assembly, P/N 3553000011

# available only in Service Kit #7577250024

# TOW OPTION HYDRAULIC EXTEND CYLINDER ASSEMBLY - P/N 3320000116 & P/N 3320000117

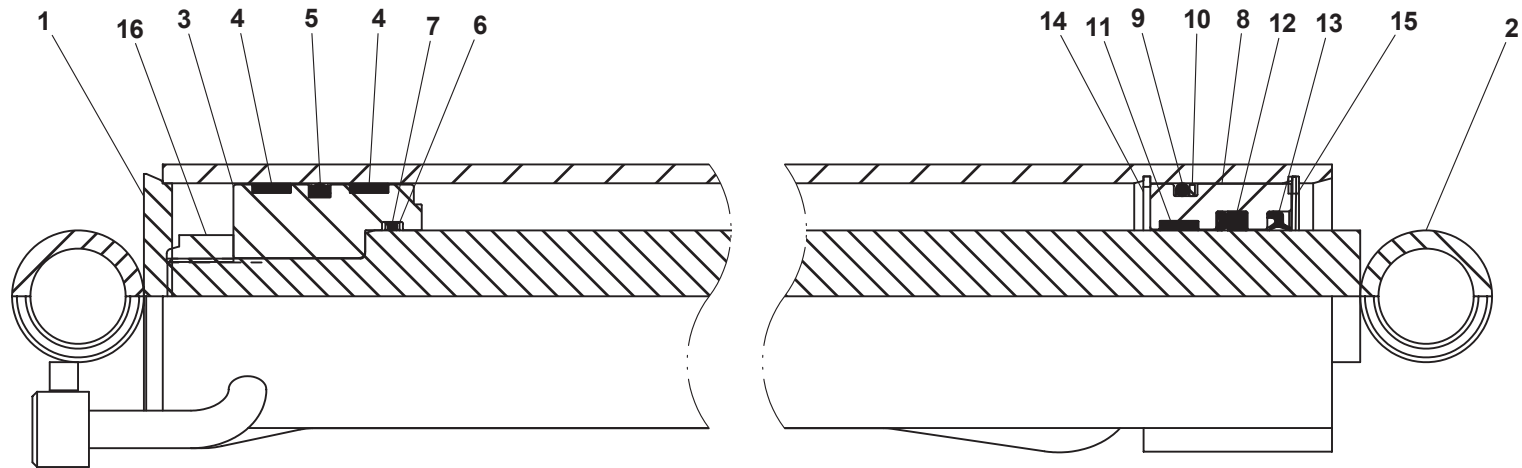

**STABILIZER CYLINDER ASSEMBLY - P/N 3320000132**

ITEM	PART NO.	DESCRIPTION	QTY
1	3071000124	Barrel Weld	1
2	3763000133	Rod Weld	1
3	4698000009*	Piston	1
4	7796000013* #	Wear Ring	2
5	7796000064* #	Piston Locking "T" Seal	1
6	7755226609* #	Back-Up Ring	2
7	7755226000* #	"O" Ring	1
8	4553000010^	Head	1
9	7755338000^ #	"O" Ring	1
10	7755338609^ #	Back-Up Ring	1
11	7754000012^ #	Wear Ring	1
12	7796000025^ #	Rod Seal	1
13	7796000011^ #	Rod Wiper Seal	1
14	7754000016 #	Retaining Ring	1
15	7754000027 #	Retaining Ring	1
16	7661000035	Locknut	1
17	7082222218	Bearing	4

\* included in Piston Assembly, P/N 3698000004

^ included in Head Assembly, P/N 3553000014

# available only in Service Kit #7577250024

# STABILIZER CYLINDER ASSEMBLY - P/N 3320000132

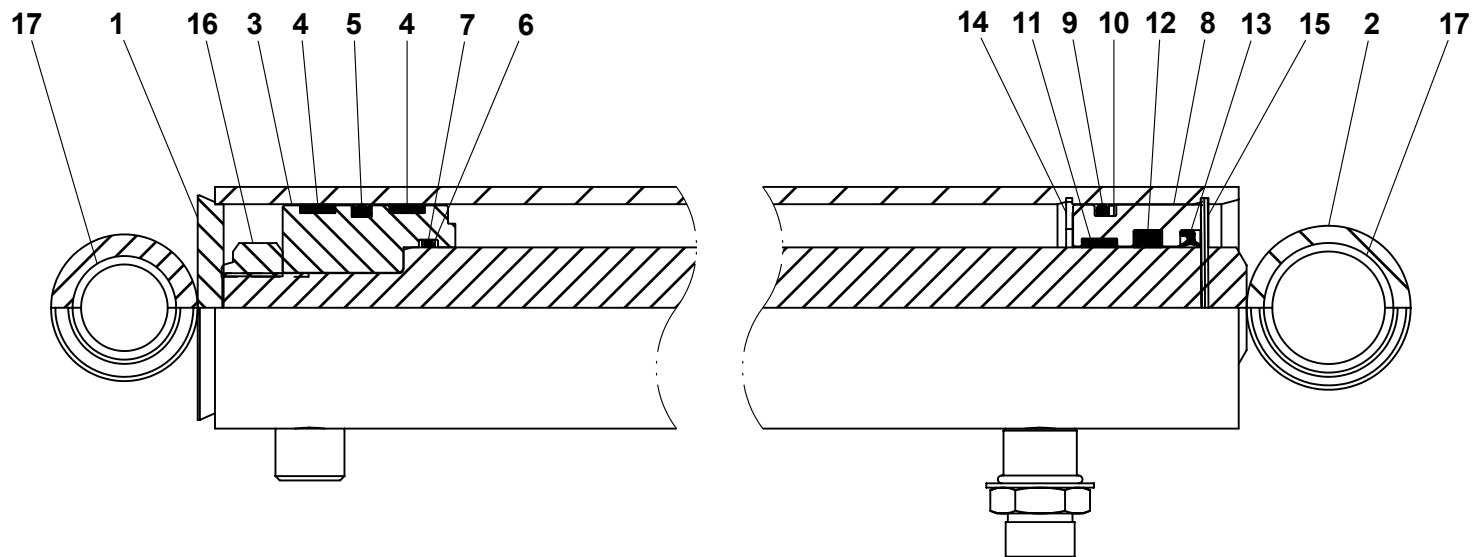

**LIGHTBARS**

ITEM	PART NO.	DESCRIPTION	QTY
1	7590000306	Lightbar, Amber Halogen	1
	7590000311	Lightbar, Amber LED	
2	4178000402	Bracket (standard mount)	2
	4178000437	Bracket (high mount)	
3	7115180850	Capscrew, 0.50"-13NC x 1.00"	2
4	7950180252	Flatwasher, 0.50" ID	2
5	7950180000	Lockwasher, 0.50" ID	2

# LIGHTBARS

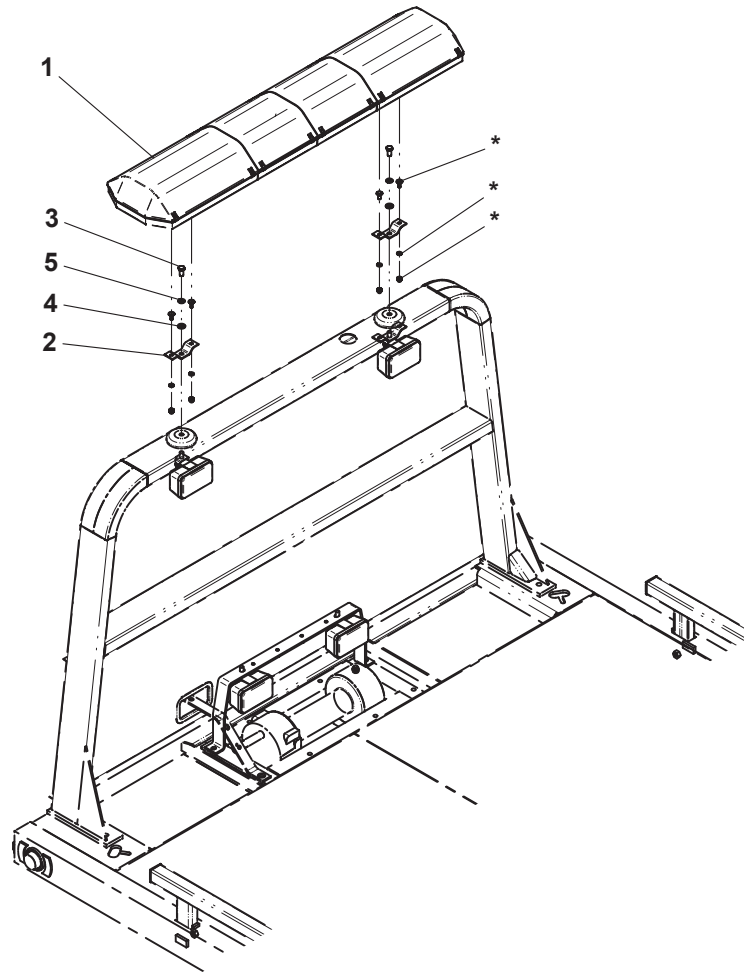

\* included in Lightbar

**SWITCH PANELS**

ITEM	PART NO.	DESCRIPTION	QTY
1	4178000403	Bracket - 1 Function Switch Panel	1
2	4178000427	Bracket - 2 Function Switch Panel	1
3	7870000083	Switch	1
4	7870000113	Switch Panel - 3 Function, Mini In-Dash	1
5	7870000100	Switch Panel - 3 Function, In-Dash	1
6	7870000106	Switch Panel - 5 Function, In-Dash	1
7	7870000076	Switch Panel - 3 Function, In-Dash for IHC4300/4400	1
8	7870000053	Switch Panel - 3 Function, Under Dash	1
9	7870000063	Switch Panel - 5 Function, Under Dash	1
10	7870000089	Switch Panel - 5 Function	1



# SWITCH PANELS

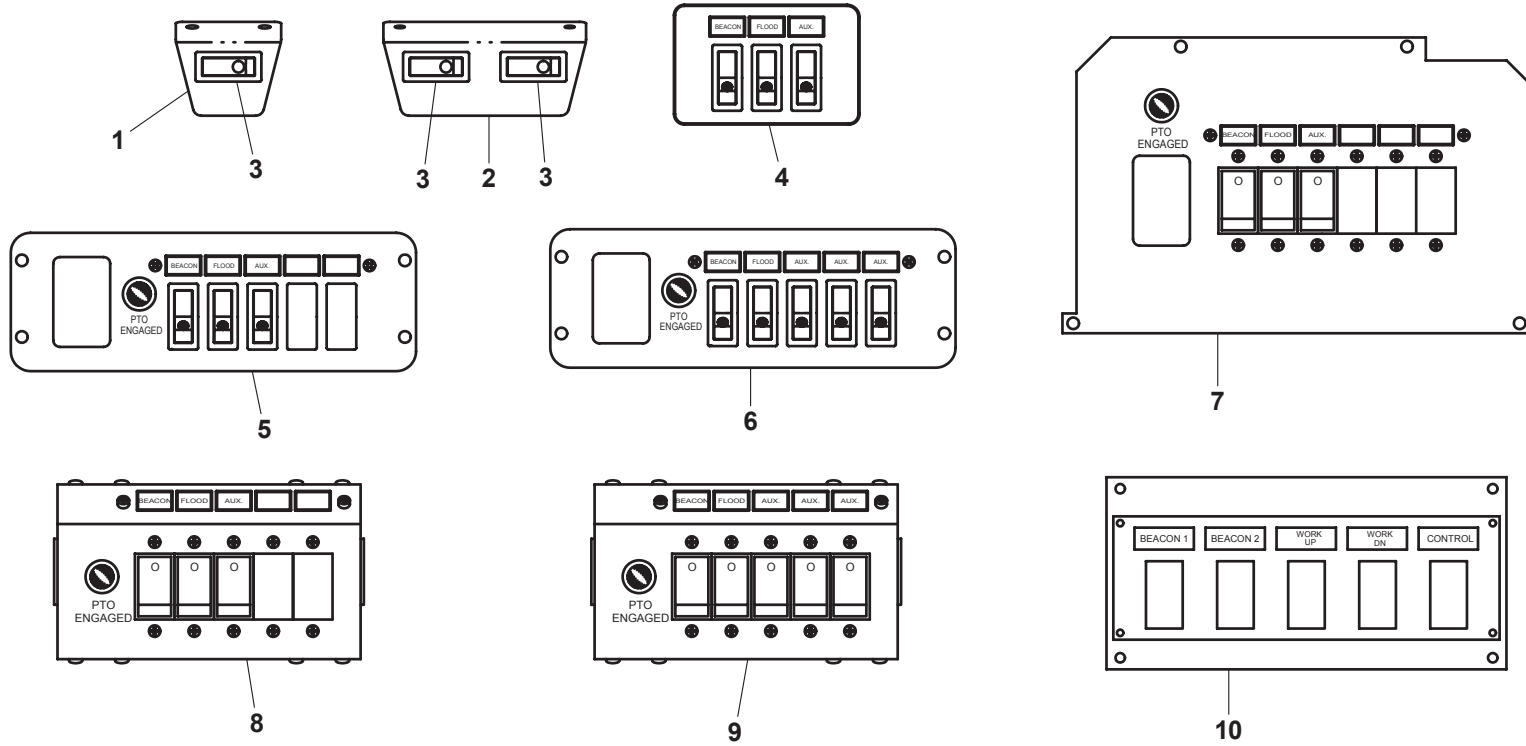

**WORK LIGHTS**

ITEM	PART NO.	DESCRIPTION	QTY
1	7590000223	Worklight	4
2	4178000402	Bracket	2
3	7790151253	Screw, 0.31"-18NC x 0.75	4
4	7493000003	Grommet	2
5	7552000222	Harness - Headboard Worklights	1
6	4178000423	Bracket (12,000 lb winch)	1
7	7280000011	Clip (12,000 lb winch)	6
	7280000013	Clip (20,000 lb winch)	4
8	7552000166	Harness - Winch Worklights	1
9	4178000425	Bracket LH (20,000 lb winch)	1
10	4178000424	Bracket RH (20,000 lb winch)	1
11	7590000185	Worklight	2

# WORK LIGHTS

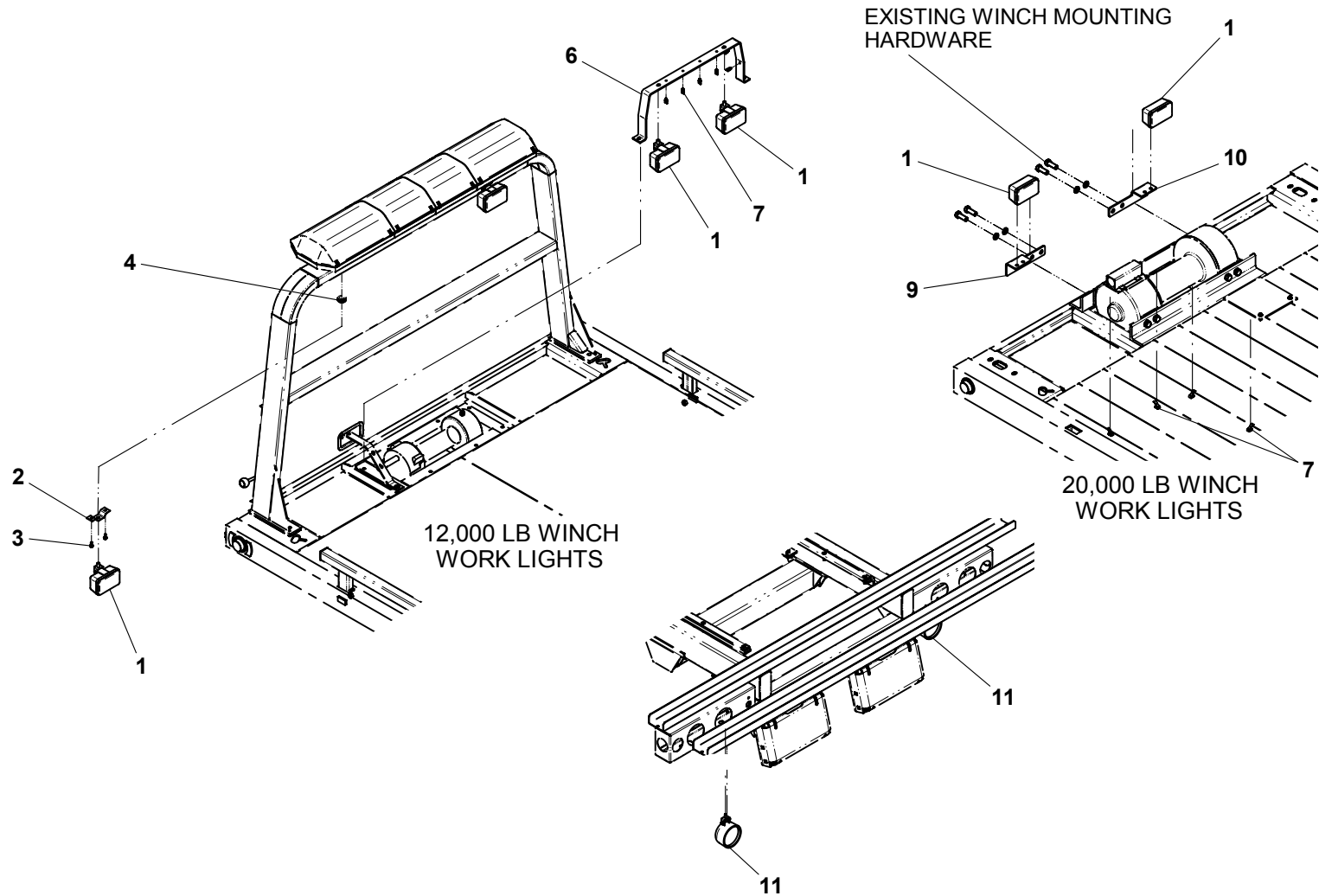

Items #5 & #8, Harness, not shown

**BOLT-ON D-RINGS**

ITEM	PART NO.	DESCRIPTION	QTY
1	3556000019	D-Ring	1
2	7115182050	Capscrew, 0.50"-13NC x 2.50"	2
3	7660182601	Locknut, 0.50"-13NC	2

## BOLT-ON D-RINGS

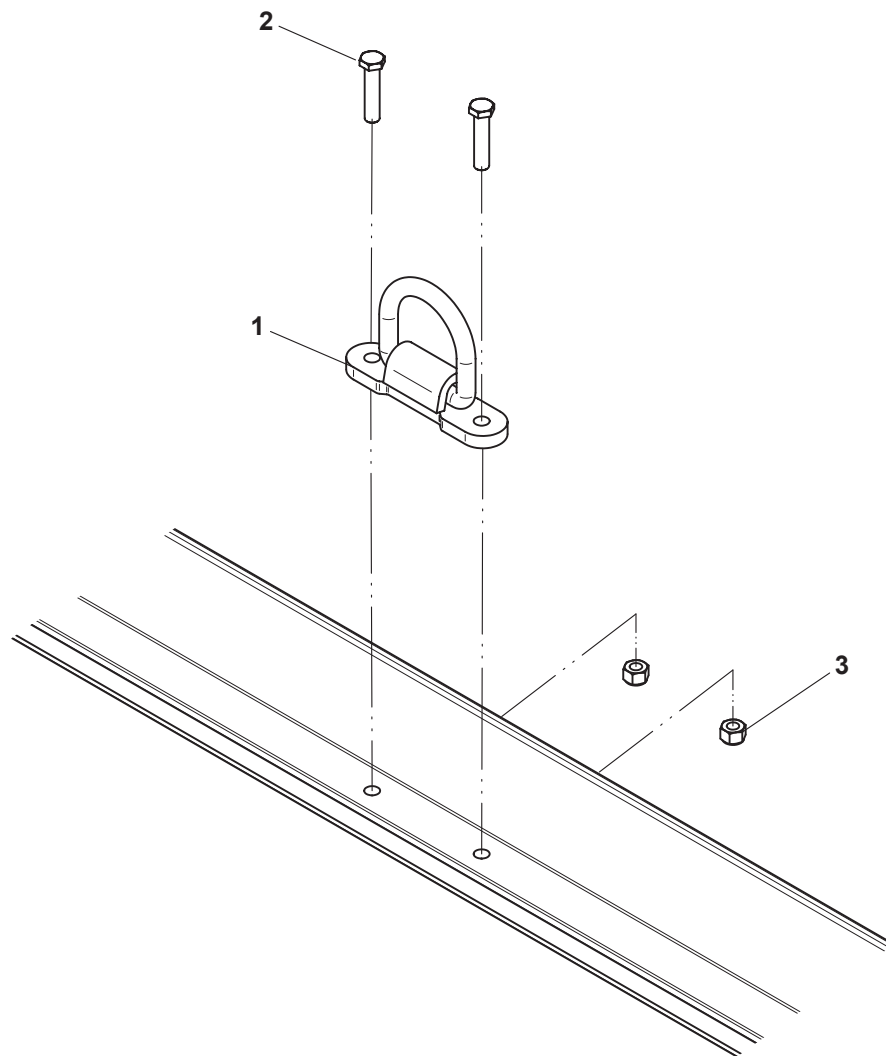

**REMOTE CONTROL OPERATION(S)**

ITEM	PART NO.	DESCRIPTION	QTY	ITEM	PART NO.	DESCRIPTION	QTY
1	7005000003	Linear Actuator 12V	1*	20	7114100818	Capscrew, #10-24NC x 1.00" (4 & 5 remote operation)	4
2	4706005361	Plate	2	21	7660102604	Locknut, #10-24NC (4 & 5 remote operations)	4
3	7115150864	Carriage Bolt, 0.31"-18NC x 1.00"	4	22	9295310018#	Transmitter (1 remote operation)	1
4	7950150161	Flatwasher, 0.31" ID	4		9295310020#	Transmitter (2 remote operations)	
5	7660152601	Locknut, 0.31"-18NC	4		9295310019#	Transmitter (3 remote operations)	
6	4178000664	Bracket	1*		7295000099#	Transmitter (4 remote operations)	
7	4178000665	Bracket	1*	23	7330000612	Decal - Controller Functions (4 & 5 remote operations)	1
8	4691000141	Pin	1	24	7115150864	Carriage Bolt, 0.31"-18NC x 1.00"	2*
9	4211000001	Bushing	4*	25	7660152601	Locknut, 0.31"-18NC	2*
10	7950220141	Flatwasher, 0.75" ID	4				
11	7754000009	Retaining Ring	2				
12	7295000097	Controller (1 remote operation)	1				
	7295000078	Controller (2 remote operations)					
	7295000075	Controller (3 remote operations)					
	7295000099	Controller (4 remote operations)					
	7295000095	Controller (5 remote operations)					
13	4706003650	Plate	1				
14	7104100613	Screw, #10-32NF x 0.34"	4				
15	7661000007	Wellnut, #10-32NF	4				
16	7115140650	Capscrew, 0.25"-20NC x 0.75" (1, 2 & 3 remote operations)	2				
	7115140650	Capscrew, 0.25"-20NC x 0.75" (4 & 5 remote operations)	5				
17	7950140141	Flatwasher, 0.25" ID (1, 2 & 3 remote operations)	2				
	7950140141	Flatwasher, 0.25" ID (4 & 5 remote operations)	5				
18	7660142601	Locknut, 0.25"-20NC (1, 2 & 3 remote operations)	2				
	7660142601	Locknut, 0.25"-20NC (4 & 5 remote operation)	5				
19	4706005396	Plate (4 & 5 remote operation)	1				

\* quantities are for 1 remote operation, adjust quantities for 2, 3, 4 & 5 remote operations

# included with Controller, item #12

# REMOTE CONTROL OPERATION(S)

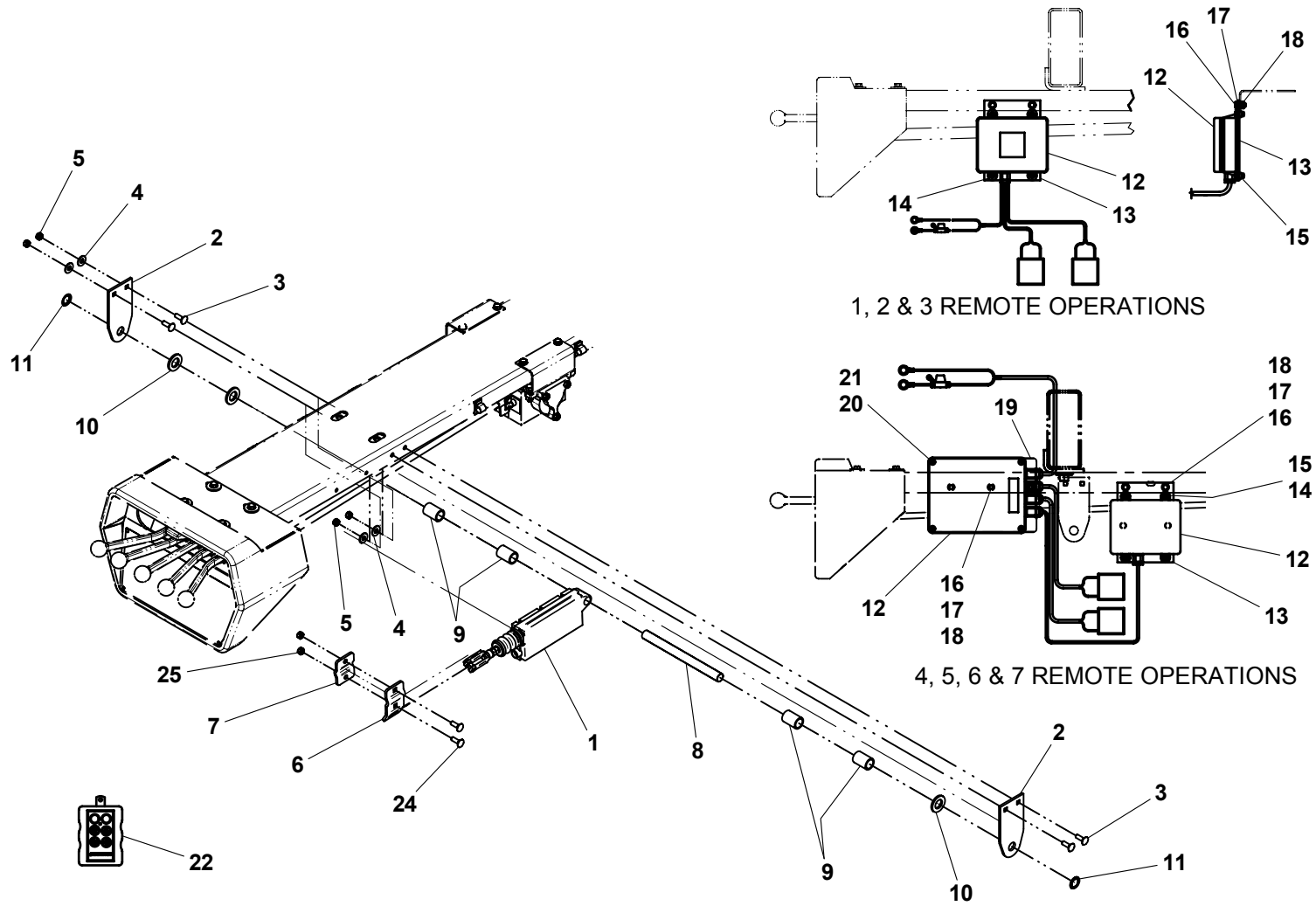

1, 2 & 3 REMOTE OPERATIONS

4, 5, 6 & 7 REMOTE OPERATIONS

Item #23, Decal- Controller Functions, not shown

One Remote Operaton shown

**REMOTE THROTTLE CONTROL**

ITEM	PART NO.	DESCRIPTION	QTY
1	7346000208	Pressure Switch	1
2	7552000241	Harness	1
3	7443000427*	Check Valve	1
4	7445060643*	Adapter	1

\* also available in Check Valve w/ Adapter, P/N 7443000428.



# REMOTE THROTTLE CONTROL

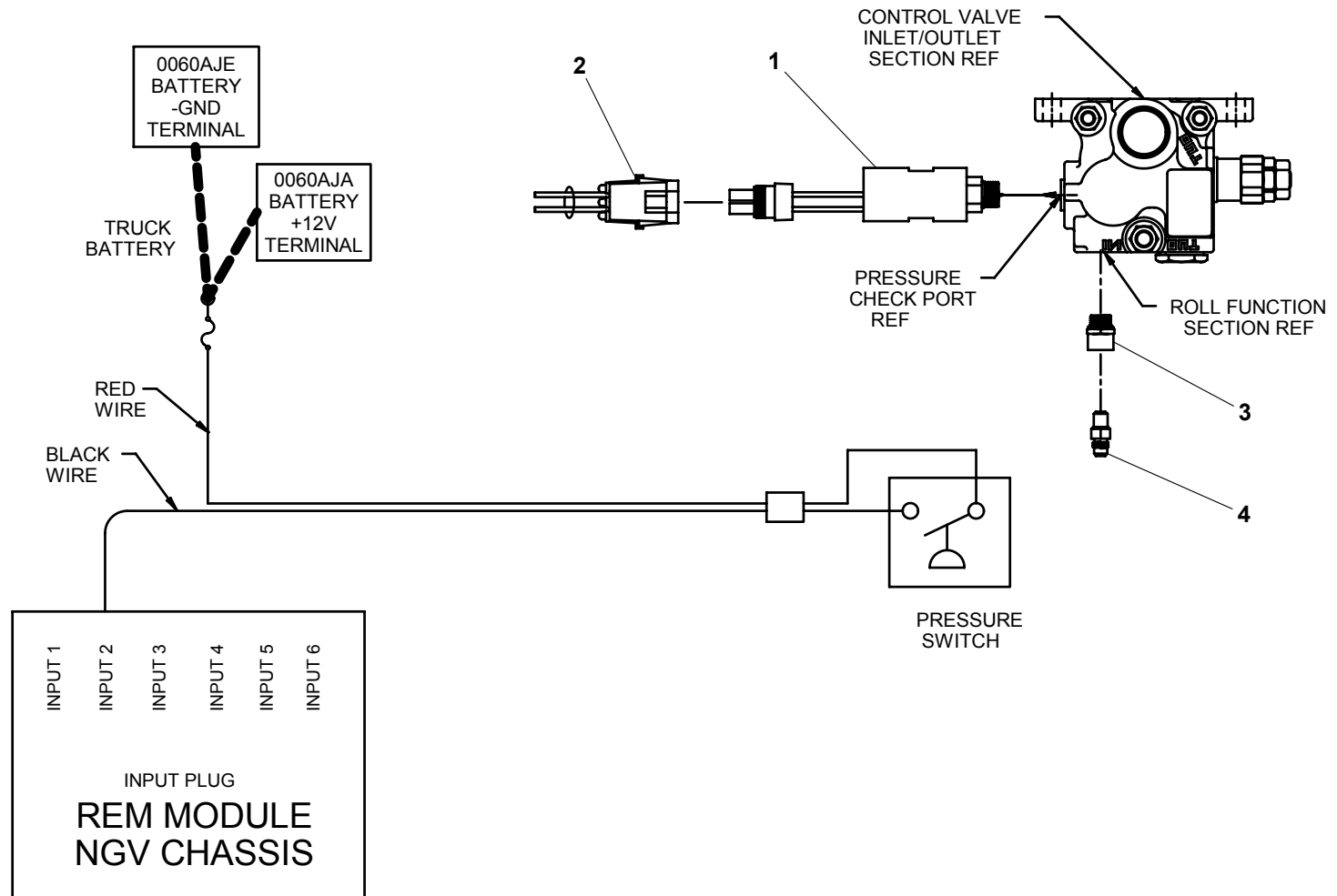

**GLAD HANDS AND 7- WAY CONNECTOR**

ITEM	PART NO.	DESCRIPTION	QTY
1	4178000666*	Bracket	1
2	7115181464*	Carriage Bolt, 0.50"-13NC x 1.75"	2
3	7660182601*	Locknut, 0.50"-13NC	2
4	7346000055+	Electrical Receptacle 7-way Connect	1
5	7346000078+	Electrical Boot	1
6	7111150813+	Capscrew, 0.31"-18NC x 1.00"	2
7	7660152601+	Locknut, 0.31"-18NC	2
8	7346000132	Electrical Adapter 7 to 4 way	1
9	7346000157	Electrical Adapter 7 to 6 way	1
10	7312000015^	Gladhand	1
11	7312000016^	Gladhand	1
12	7446502518^	Bulkhead Fitting	2
13	7446382506^	Connector	2
14	7577000145^	Seal Kit Gladhand	1
15	7565000014^	Airline Tubing	50 ft
16	7312000013^	Union	2

\* also available in Bracket Install Glad Hands and 7 Way, P/N 2178000037

+ also available in Electrical Install 7 Way Connector, P/N 2346000008

^ also available in Glad Hand Install, P/N 2002000016

## GLAD HANDS AND 7- WAY CONNECTOR

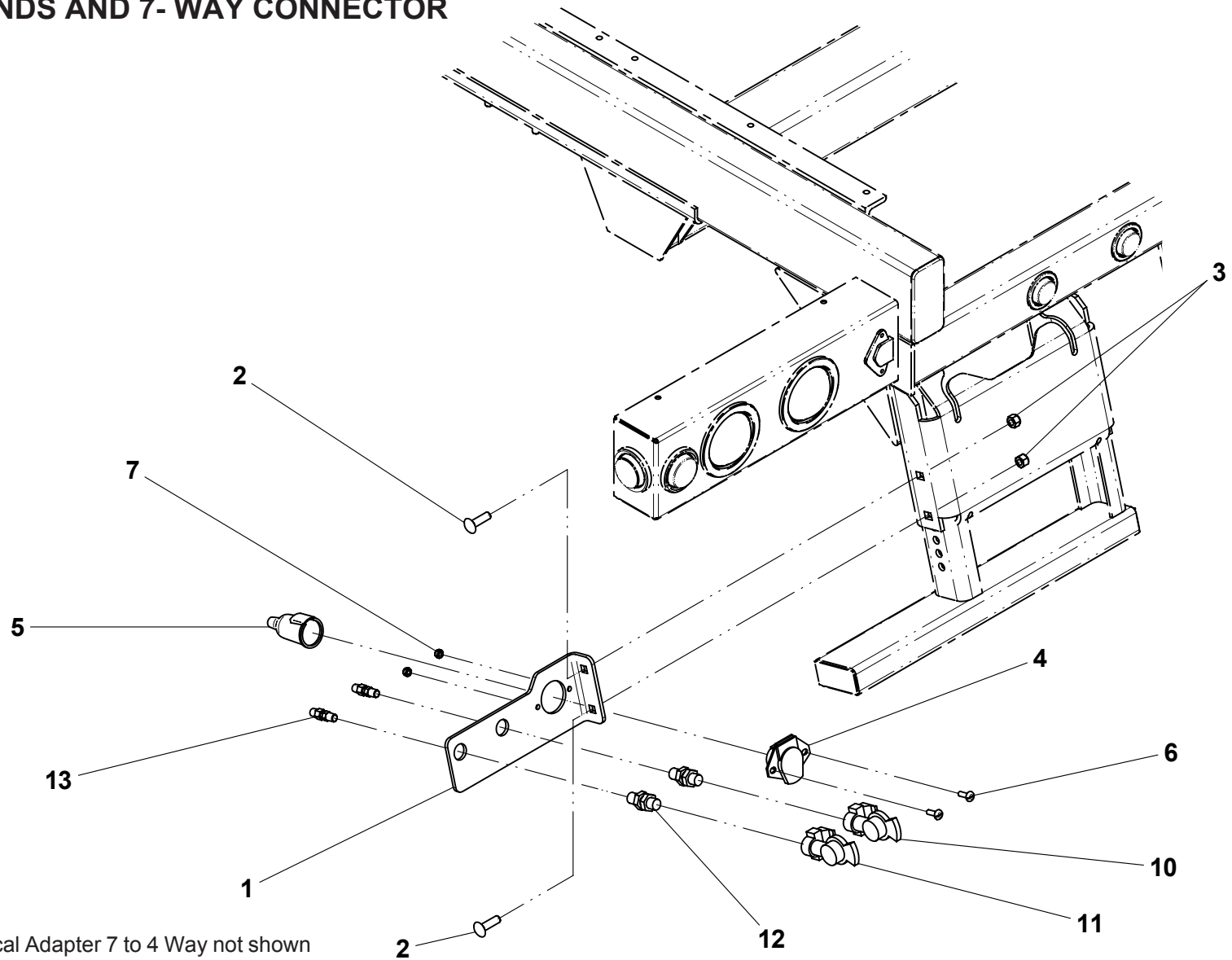

Item #8 Electrical Adapter 7 to 4 Way not shown  
Item #9 Electrical Adapter 7 to 6 Way not shown  
Item #14, Seal Kit Gladhand; #15, Airline Tubing; & #16, Union not shown

**AIR SUPPLY DISCONNECT**

ITEM	PART NO.	DESCRIPTION	QTY
1	7312000017	Coupling	1
2	7445080853	Elbow	1
3	7446502518	Bulkhead Fitting	1
4	7443000111	Elbow	1
5	7446382506	Connector	1
6	7565000014	Airline Tubing	32 ft
7	7935000120	Air Valve	1
8	7443000154	Bushing	1
9	7443000156	Nipple	1
10	7894000031	Cable Tie	6
11	7443000366	Fitting	1

# AIR SUPPLY DISCONNECT

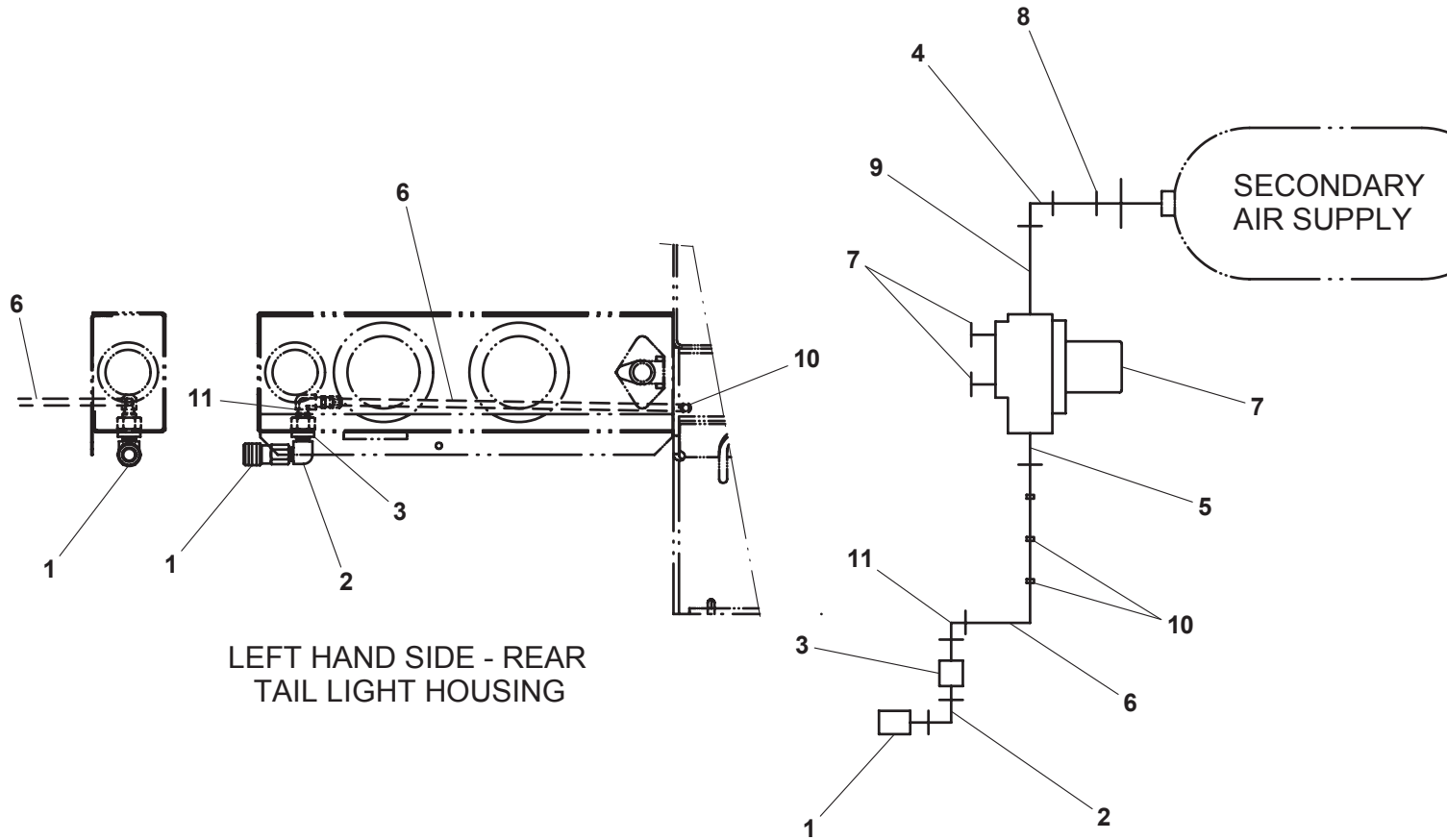

**JUMP START KIT**

ITEM	PART NO.	DESCRIPTION	QTY
1	7002000386	Jump Start Plug (IHC & Other)	1
	7002000385	Jump Start Plug (Ford & Chevy)	
2	4178000372	Bracket (Ford & Other)	1
	4178000202	Bracket (Chevy)	
3	4178000203	Bracket (Chevy)	1
	4706003210	Plate (Other)	
4	7110140605	Capscrew, 0.25"-20NC x 0.75" (Ford, Chevy & Other)	1
5	7950140161	Flatwasher, 0.25" ID (Ford & Other)	1
	7950140161	Flatwasher, 0.25" ID (IHC)	2
	7950140161	Flatwasher, 0.25" ID (Chevy)	3
6	7660142600	Locknut, 0.25"-20NC (Ford, Chevy & Other)	1
	7660142600	Locknut, 0.25"-20NC (IHC)	2
7	7115151064	Carriage Bolt, 0.31"-18NC x 1.25" (Other)	2
8	7950150161	Flatwasher, 0.31" ID (Other)	2
9	7660152601	Locknut, 0.31"-18NC (Other)	2
10	7115141450	Capscrew, 0.25"-20NC x 1.75" (IHC)	1
11	7115141650	CapScrew, 0.25"-20NC x 2.00" (IHC)	1
12	7660140000	Hex Nut, 0.25"-20NC (IHC)	1
	7660140000	Hex Nut, 0.25"-20NC (Chevy)	2
13	7111140850	Capscrew, 0.25"-20NC x 1.00" (Chevy)	2
14	7115181050	Capscrew, 0.50"-13NC x 1.25" (Chevy)	1
15	7950180153	Flatwasher, 0.50" ID (Chevy)	1
16	7660180000	Hex Nut, 0.50"-13NC (Chevy)	1

# JUMP START KIT

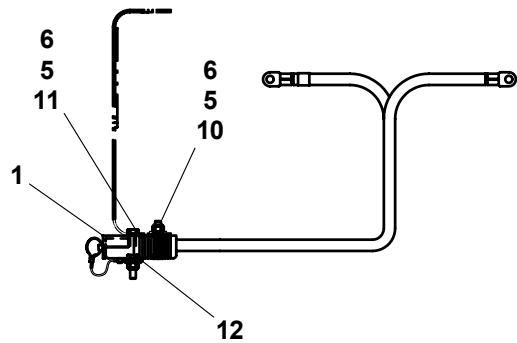

IHC FRONT BUMPER

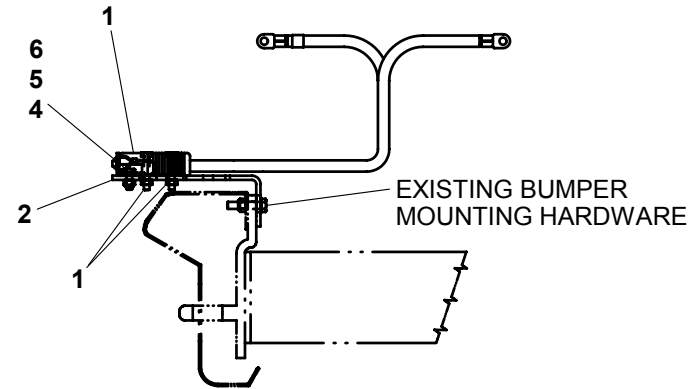

FORD FRONT BUMPER

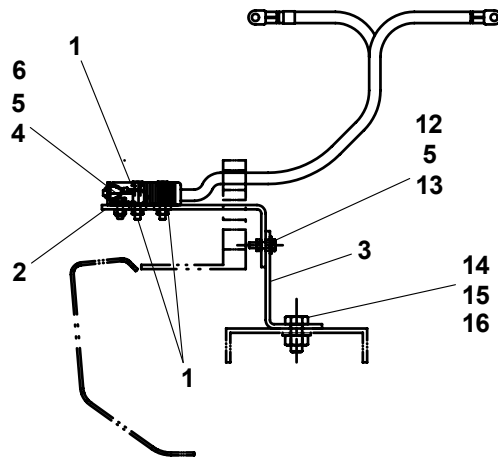

CHEVY FRONT BUMPER

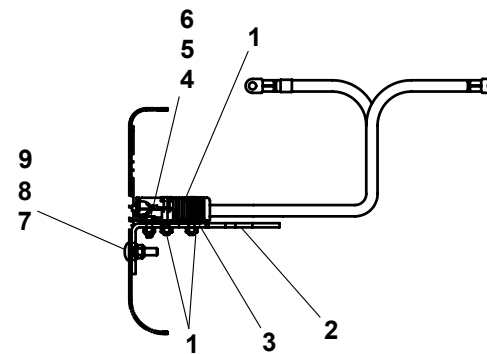

ALL OTHER FRONT BUMPERS

**FOLDING DECK LADDER**

ITEM	PART NO.	DESCRIPTION	QTY
1	3178000321	Bracket Weld	1
2	3002000009	Ladder Top Weld	1
3	3002000008	Ladder Bottom Weld	1
4	7114181418	Capscrew, 0.50"-13NC x 1.75"	4
5	7950180141	Flatwasher, 0.50" ID	12
6	7660182601	Locknut, 0.50"-13NC	4
7	7115180606	Shoulder Bolt, 0.50"-13NC x 0.75"	2
8	7950160141	Flatwasher, 0.38" ID	2
9	7660162601	Locknut, 0.38"-16NC	2



# FOLDING DECK LADDER

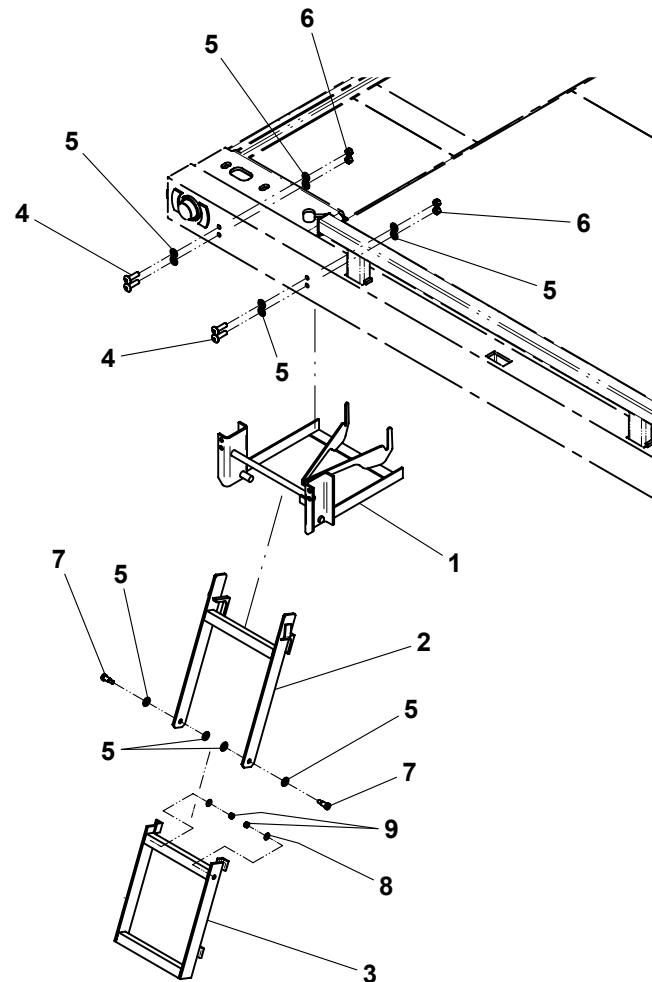

**CHAIN AND STRAPS**

ITEM	PART NO.	DESCRIPTION	QTY
1	7262000040	Wheel Lift Chain	2
2	7894000034*	Wheel Lift Tire Strap	2
3	7262000010	Towbar Chain (3,500 lb towbar)	2
4	7262000011	Towbar Chain (5,000 lb towbar)	2
5	7262000014	Towbar Chain (5,000 lb towbar)	2
6	7115181664	Carriage Bolt, 0.50"-13NC x 2.00"	2
7	7660180001	Nut, 0.50"-13NC	2
8	7660182601	Locknut, 0.50"-13NC	2

\* also available in Wheel Lift Tie-Down Strap & Ratchet Kit, P/N 7577000242

# CHAIN AND STRAPS

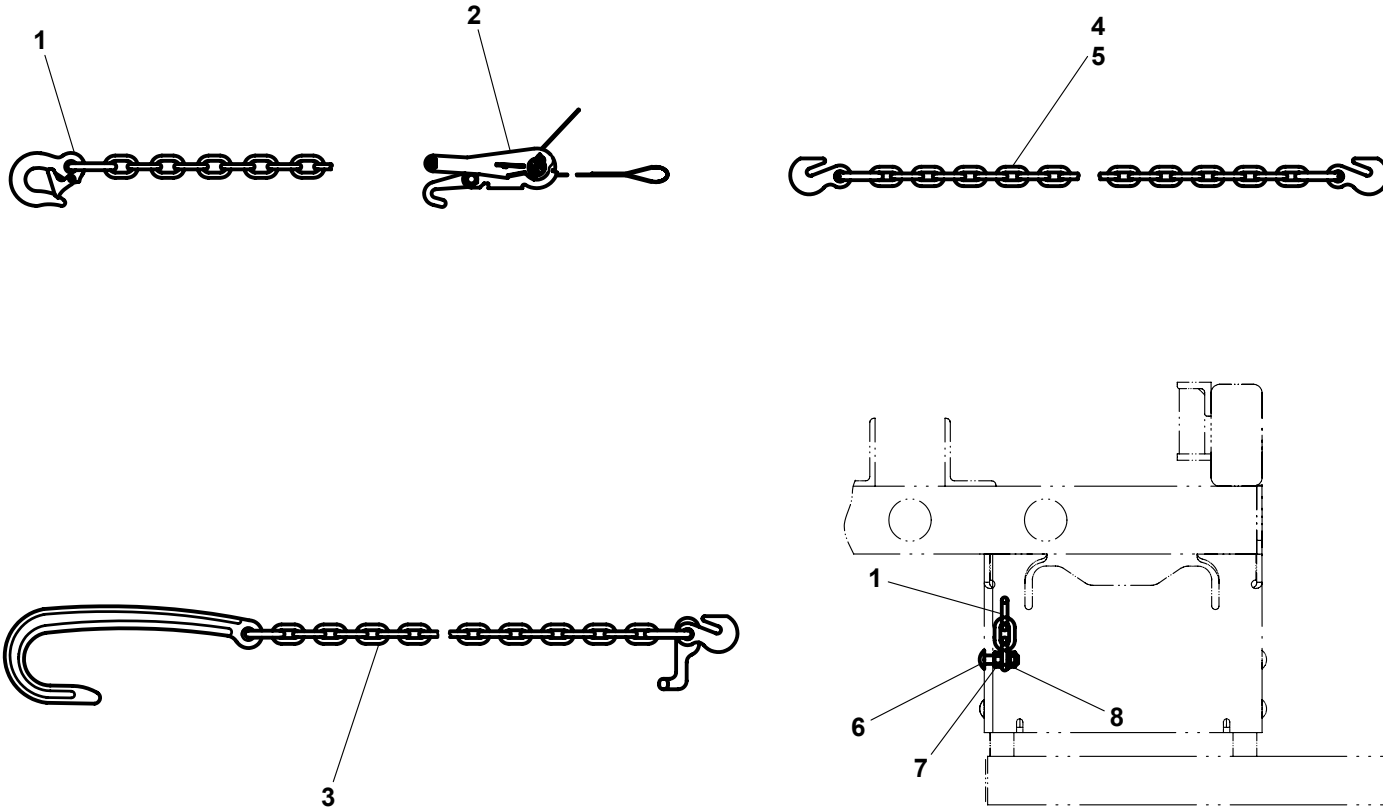

CHAIN BOX AT REAR OF SUBFRAME

**DECALS**

ITEM	PART NO.	DESCRIPTION	QTY
1	7330000167	Serial Number Tag	1
2	7330000338	Subframe / Patent Tag	1
3	7330000502	Decal - Slide Pad / Pivot Joint	1
4	7330000376	Structural Rating Placard	1
5	7330000275	Decal - Operator's Pre-Checklist	1
6	7330000242	Decal - Free Spool (bolt-on headboard & 12,000 lb winch)	1
	7330000495	Decal - Free Spool (stationary headboard & 12,000 lb winch)	1
	7330000511	Decal - Air- Free Spool (20,000 lb winch)	1
7	7330000478	Decal - Lubrication Chart	1
8	7330000012	Decal - Winch	1
9	7330000408	Jerr-Dan Nameplate	3
10	7330000143	Decal - Made In The USA	1
11	7330000045	Decal - Align Arrow, White	2
12	7330000272	Decal - Oil Level	1
13	7759000004	Pop Rivet	12
14	7330000139	Decal - Checklist Reminder	1
15	7330000684	Decal - Safety	1
16	7330000683	Decal - Safety	2
17	7330000060	Decal - Wheel Lift Hitch	1
18	7330000391	Decal - Tow Boom Configuration	1
19	7330000274	Decal - Overloading Tow Option	1
20	7330000599	Decal - Pinch Point	3
21	7330000390	Decal - Stabilizer W/ 4,000 lb W/L	2
22	9330740009	Decal Kit - Muncie PTO	1

# DECALS

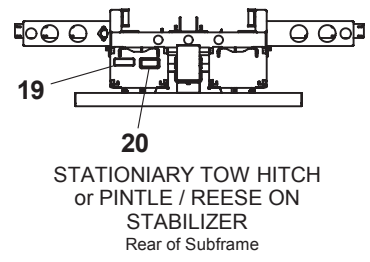
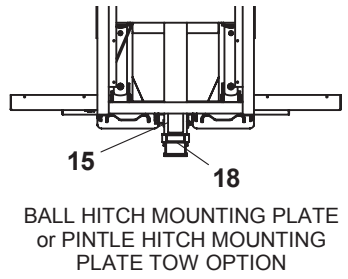
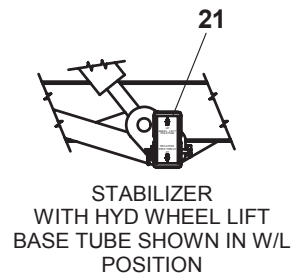
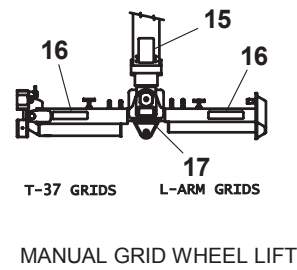
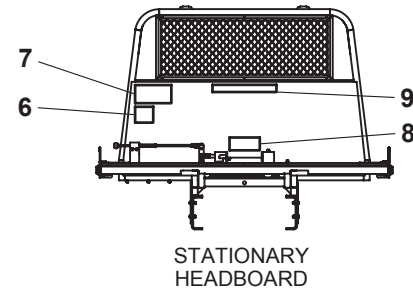
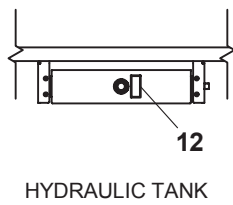
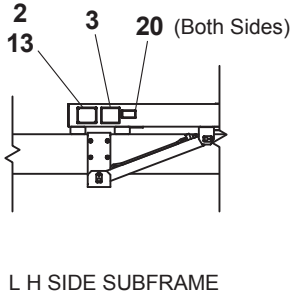
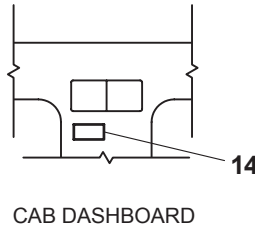
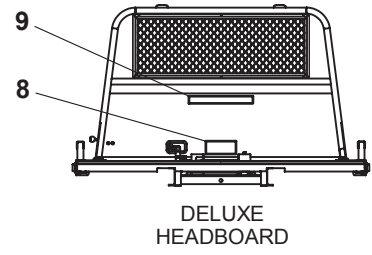
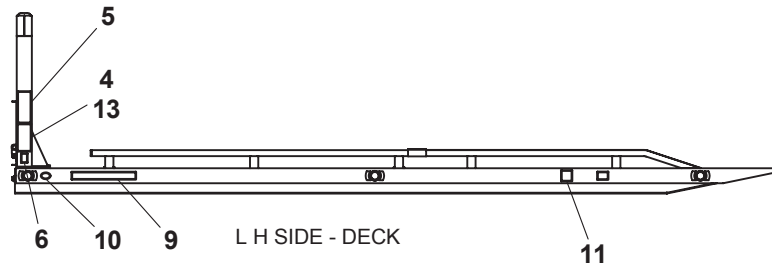
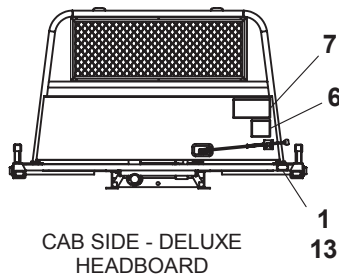

Item #22, Decal Kit, not shown



# HYDRAULIC SCHEMATIC

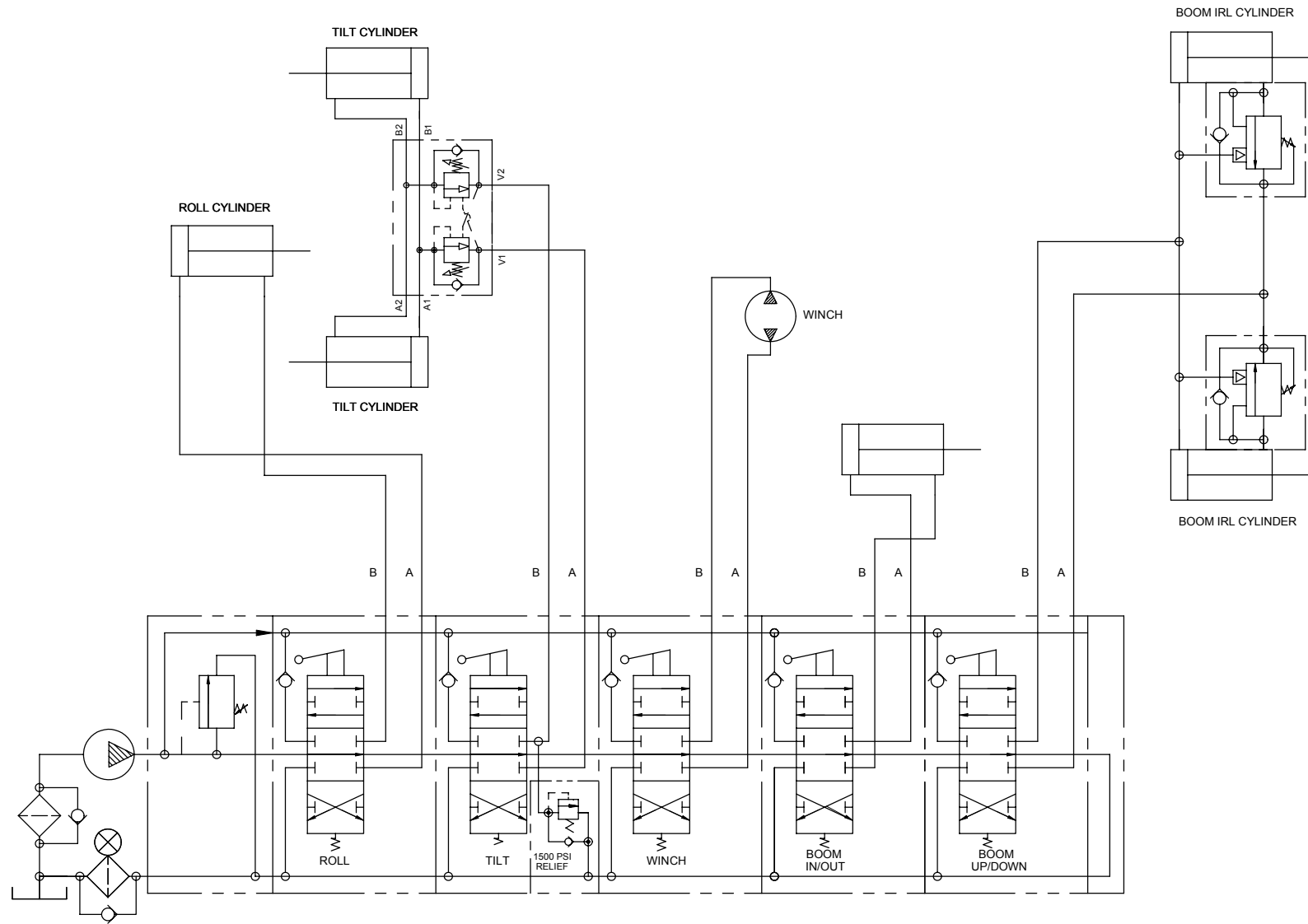

5 Bank Control Valve - IRL Tow Options

# HYDRAULIC SCHEMATIC

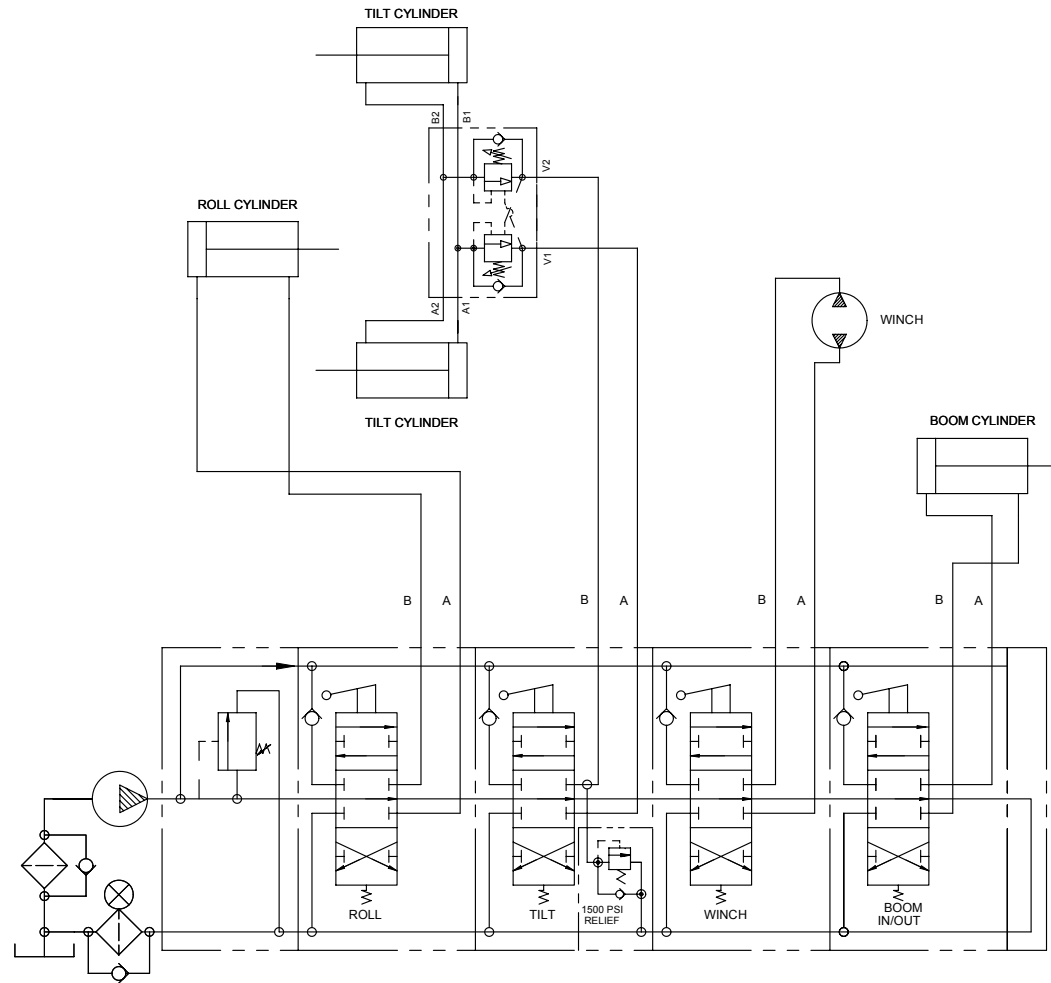

6 Bank Control Valve - ZOD Tow Option



# HYDRAULIC SCHEMATIC

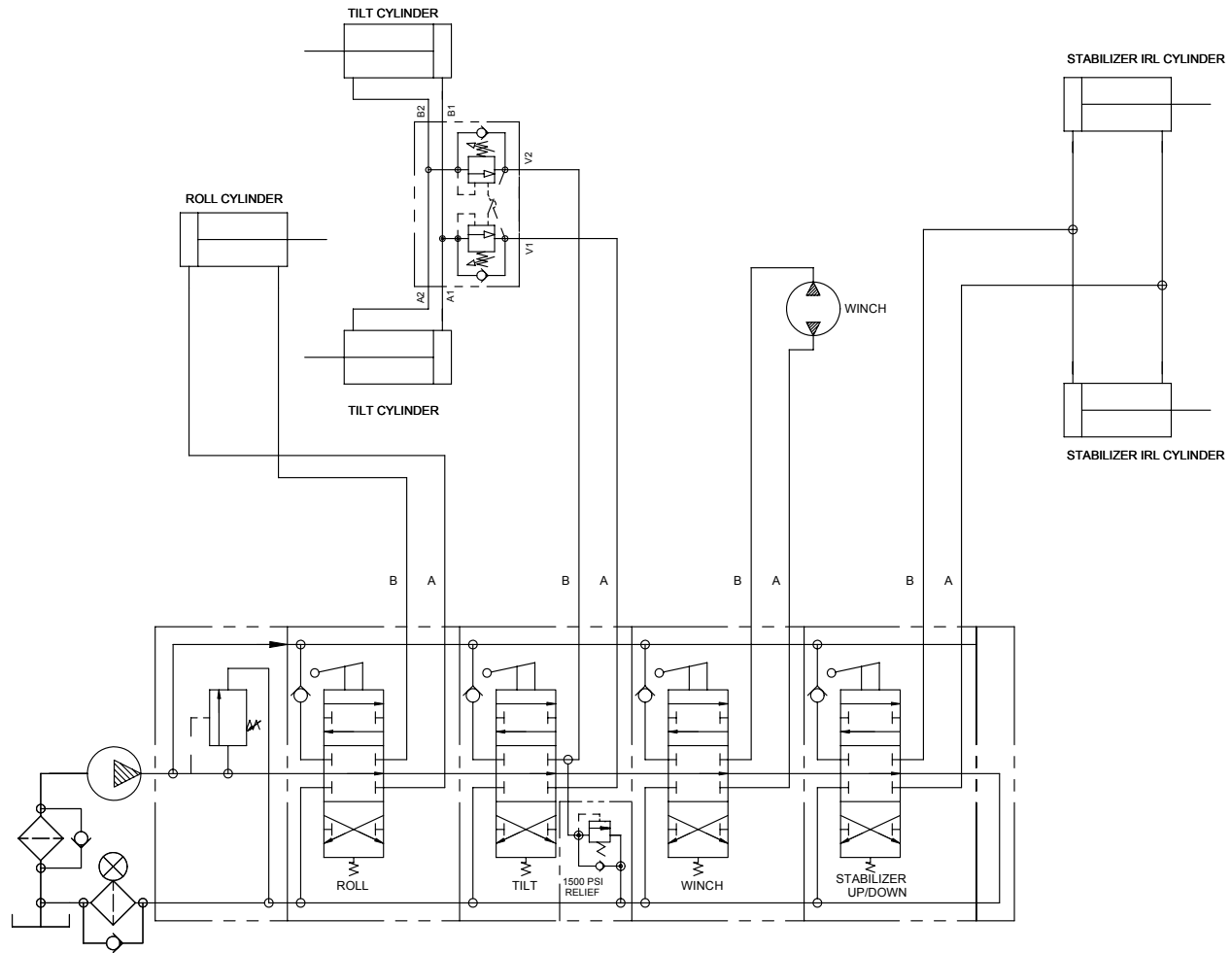

4 Bank Control Valve - Hydraulic Extended Boom Tow Options

# HYDRAULIC SCHEMATIC

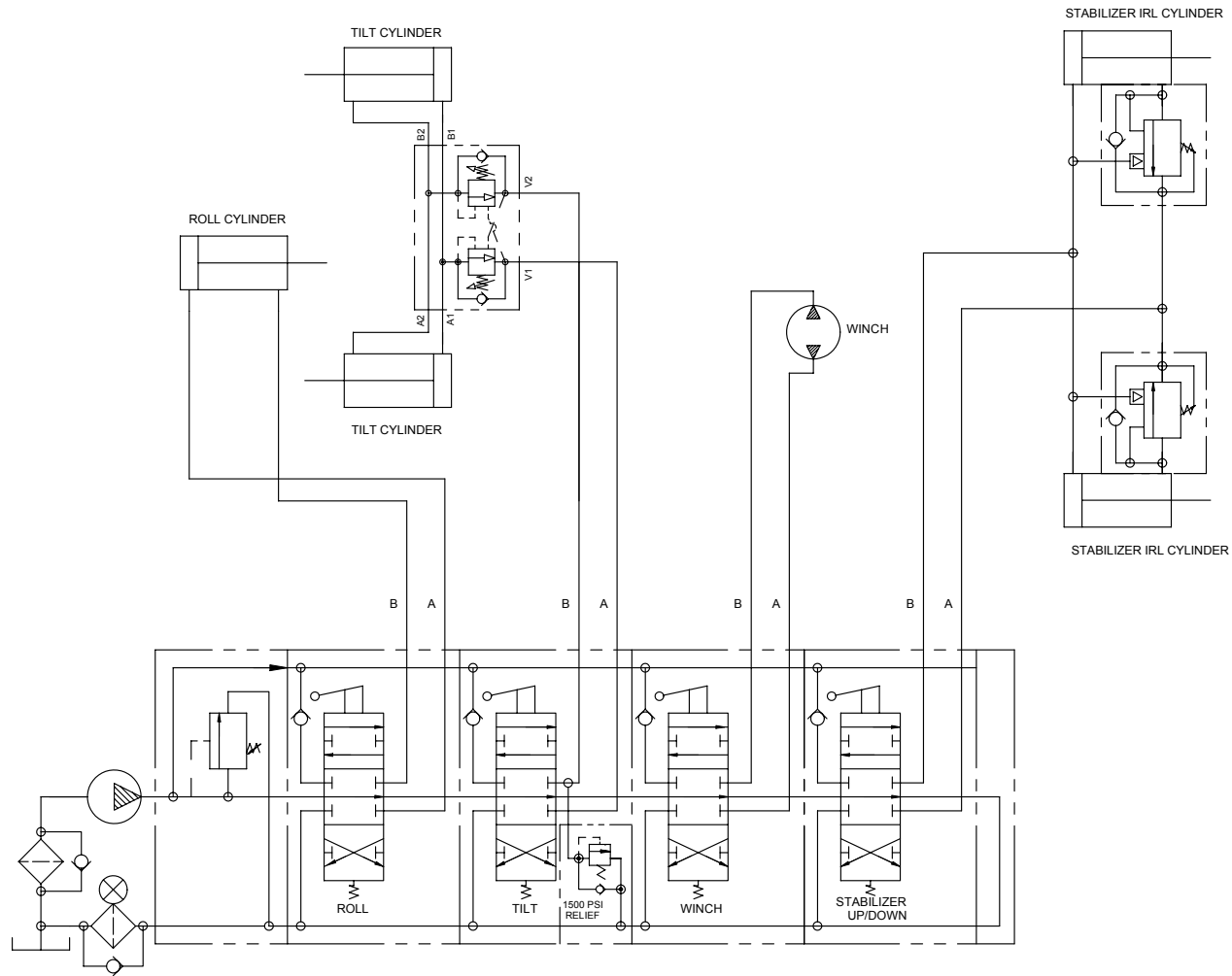

4 Bank Control Valve - Stabilizer Option

# HYDRAULIC SCHEMATIC

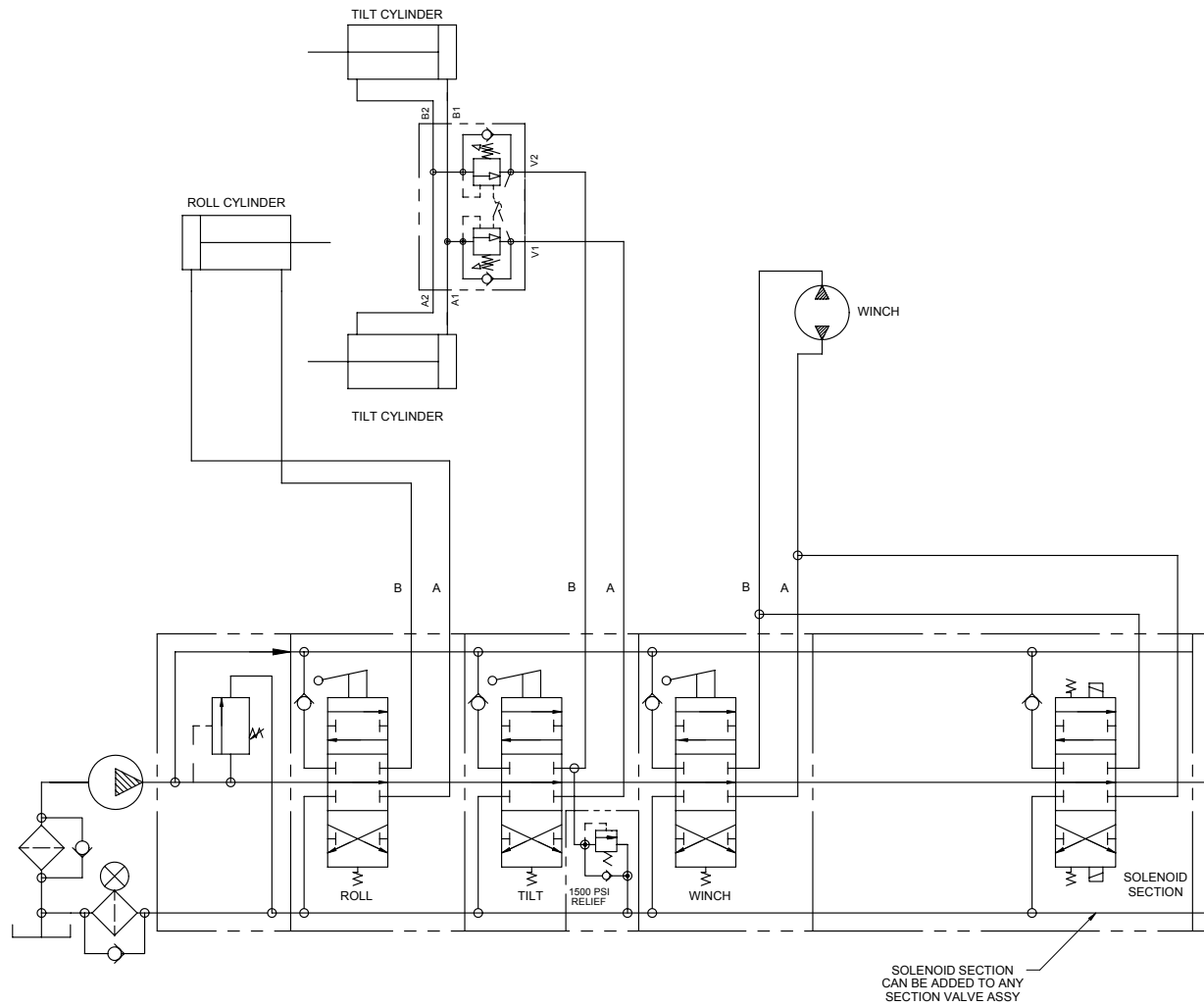

4 Bank Control Valve - Stabilizer with Tow

