

# JD50INT HEAVY DUTY WRECKER PARTS MANUAL

# ***JERR-DAN***<sup>®</sup>

An Oshkosh Corporation Company

13224 Fountainhead Plaza  
Hagerstown, MD 21742  
Phone (717) 597-7111  
[www.jerr-dan.com](http://www.jerr-dan.com)

5-376-000143  
Rev 0 - September 01, 2010

© 2010 Jerr-Dan Corporation. All Rights Reserved.



This manual covers the following Jerr-Dan Models:

### JD50INT - 50 Ton Integrated

Jerr-Dan Corporation strives to provide information that is accurate, complete and useful. Descriptions and illustrative material contained within this manual are as accurate as known at the time of publication and are subject to change, without notice, as a result of continuous product improvements. Jerr-Dan reserves the right to amend the information in this document at any time without prior notice.

Information contained in this manual reflects how this vehicle was built at the factory. Modifications or additions by the distributor or owner are not reflected in this manual.

This parts manual does not include service parts information for the commercial chassis (IHC, Ford, GM, etc.). That information is provided by the chassis manufacturer.

When ordering parts, please refer to your unit's Serial Number and Model Number. This information is be found on the aluminum tag riveted to the inside of the driver's side rear compartment of the main body.

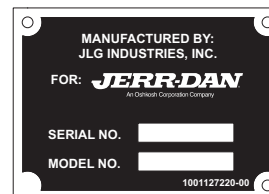

Additional or replacement manuals can be ordered by calling Jerr-Dan Parts at 717-597-7111. Price and availability will be quoted at time of the request.

Please report comments and/or errors by contacting Jerr-Dan Corporation's Technical Publications Department by e-mail at [technicalpublications@jerr-dan.com](mailto:technicalpublications@jerr-dan.com) or by FAX on 717-485-7162.

Manufactured under one or more of the following patents: 5,575,606; 5,672,042; 5,697,741; 5,713,714; 5,722,810; 5,782,596; 5,839,775 and 6,315,515 B1 with other Patents Pending.

Jerr-Dan and the Jerr-Dan logo are registered trademarks and Run Hard is a service mark of Jerr-Dan Corporation, Greencastle, PA USA.

The material in this document is confidential and the property of Jerr-Dan Corporation. No part of this document may be photocopied, reproduced or translated to another language without the express written consent of Jerr-Dan Corporation.

**THIS PAGE INTENTIONALLY LEFT BLANK**



# INDEX

DESCRIPTION	PAGE
Subframe Installation .....	6 - 7
Subframe Hydraulic Tubing .....	8 - 11
Hydraulic Tank Installation .....	12 - 13
Hydraulic Tank Assembly .....	14 - 15
Rear Spade Installation .....	16 - 17
Rear Spade Tubing .....	18 - 19
Boom Installation - 2 Piece Boom .....	20 - 21
Wrecker Boom Assembly - 2 Piece Boom .....	22 - 23
Boom Installation - 3 Piece Boom .....	24 - 25
Wrecker Boom Assembly - 3 Piece Boom .....	26 - 27
Winch Installation - 50K DP Planetary 2 Speed Motor Shift (Standard) .....	28 - 29
Winch Installation - 50K DP Planetary 2 Speed Gear Shift (Optional) .....	30 - 31
Winch Installation - 50K Ramsey Planetary 2 Speed (Optional) .....	32 - 33
Boom Tube Assembly .....	34 - 35
Underlift Installation - 53,000 LB (Standard) .....	36 - 37
Underlift Installation - 56,500 LB (Optional) .....	38 - 39
Underlift Assembly - 3507100001 - 53,000 LB (Standard) .....	40 - 41
Underlift Assembly - 3170000407 - 56,500 LB (Optional) .....	42 - 43
Crosstube Installation .....	44 - 45
Underlift Tools - Frame Forks .....	46 - 47
Underlift Tools - 14,000 LB Tire Lift .....	48 - 49
Underlift Tools - 25,000 LB Tire Lift .....	50 - 51
Underlift Tools - Fifth Wheel Attachment .....	52 - 53
Underlift Tools - Pintle Hook .....	54 - 55
Rear Tail Plate Installation .....	56 - 57
Tailboard D-Ring Installation .....	58 - 59
Controls - Control Valve Installation .....	60 - 61
Controls - Push-Pull Cables Installation .....	62 - 63
Controls - Control Valve Assembly .....	64 - 65
Controls - 6 Function Non-Proportional Miratron .....	66 - 67
Controls - 12 Function Non-Proportional Miratron .....	68 - 69
Controls - 12 Function Proportional Miratron .....	70 - 71
Controls - Electrical Emergency Stop .....	72 - 73
Hydraulics - Supply-Pressure-Return .....	74 - 75
Hydraulics - Lines and Fittings .....	76 - 81
Driver Side Hydraulic Pressure Gauges .....	82 - 83
Passenger Side Winch Air Controls - 2 Spd Gear Shift .....	84 - 85
Driver & Passenger Side Winch Air Controls - DP 50K, 2 Spd Gear Shift .....	86 - 89
Driver & Passenger Side Winch Air Controls - DP50K, Ramsey 50K, 2 Spd Motor Shift .....	90 - 93
Winch Electric Speed Controls - DP50K, Ramsey 50K, 2 Spd Motor Shift .....	94 - 95
Winch Electric Speed/Free Spools Controls - DP50K, Ramsey 50K, 2 Spd .....	96 - 99
Decals .....	100 - 102

**SUBFRAME INSTALLATION**

ITEM	PART NO.	DESCRIPTION	QTY
1	4706002262	Plate	2
2	4706006018	Plate	2
3	4706002490	Plate	2
4	4706006016	Plate	2
5	7118221816	Capscrew, 0.75"-10NC x 2.25"	15
6	7660222308	Locknut, 0.75"-10NC	15
7	7118242450	Capscrew, 0.88"-9NC x 3.00"	6
8	7949000061	Flatwasher, 0.88" ID	6
9	7660252308	Locknut, 0.88"-9NC	6
10	4062000269	Bar	2
11	4062000268	Bar	2
12	4706002555	Plate	2
13	4706002556	Plate	2
14	3868000305	Subframe	1

# SUBFRAME INSTALLATION

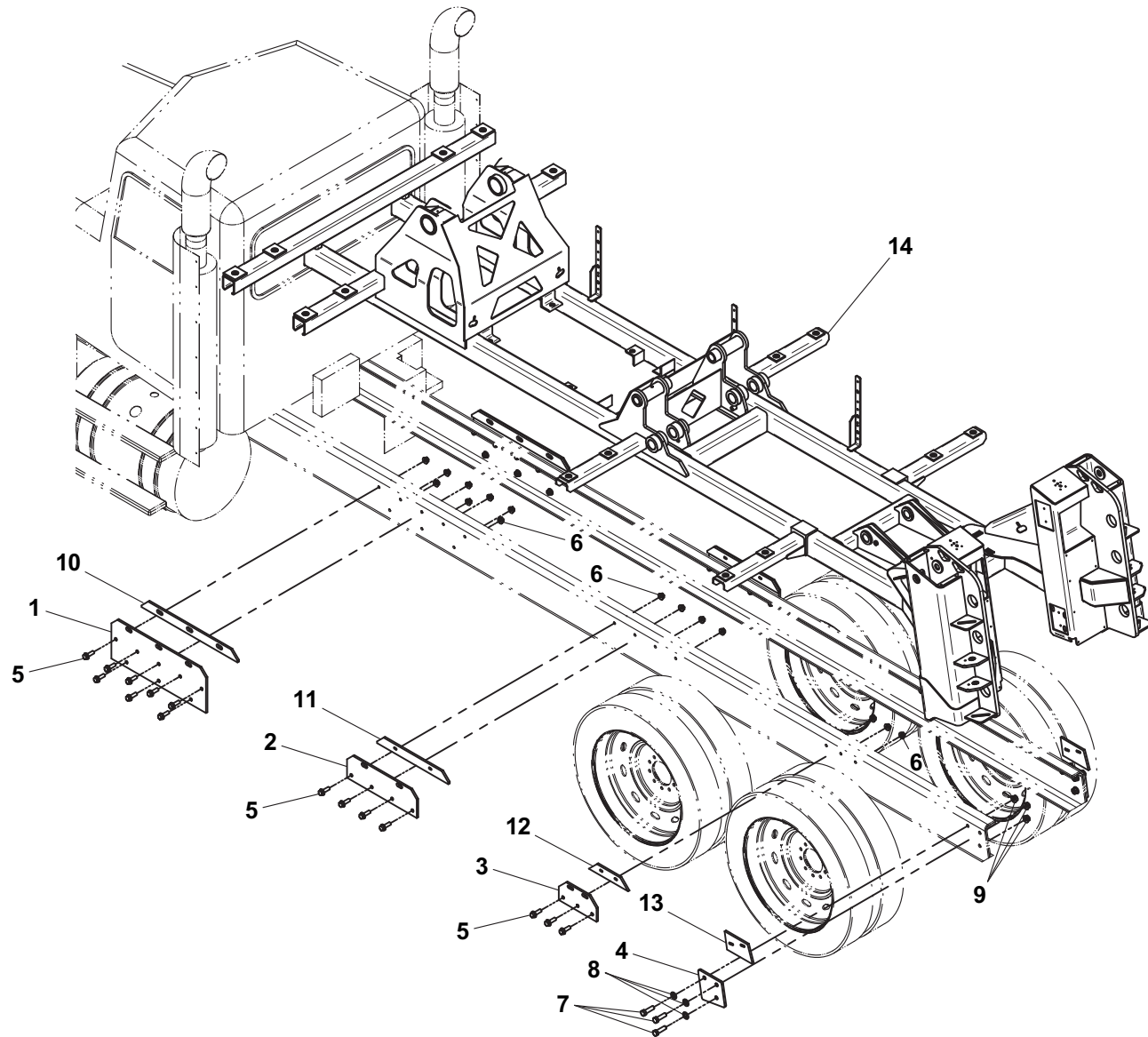

**SUBFRAME HYDRAULIC TUBING**

ITEM	PART NO.	DESCRIPTION	QTY
1	7274000030	Clamp	12
2	7274000049	Clamp	16
3	7209000023	Bushing, 0.50" ID	16
4	7209000024	Bushing, 0.63" ID	12
5	7209000032	Bushing, #12 Tube	6
6	7209000031	Bushing, #8 Tube	6
7	7209000033	Bushing, #16 Tube	4
8	7661000022	Nut, 0.31"-18NC Stacking Head	18
9	7661000027	Nut, Stacking	24
10	7007000036	Adapter, 0.31"-18NC x 1.38"	18
11	7590150000	Lockwasher, 0.31" ID	48
12	7115150650	Capscrew, 0.31"-18NC x 0.75"	32
13	7115150850	Capscrew, 0.31"-18NC x 1.00"	16
14	7445080825	Fitting, Union Bulkhead	6
15	7445101025	Fitting, Union Bulkhead	4
16	7445121225	Fitting, Union Bulkhead	2
17	7912000068	Tube Assembly	2
18	7912000069	Tube Assembly	2
19	7912000070	Tube Assembly	2
20	7912000340	Tube Assembly	6
21	7912000341	Tube Assembly	4

## SUBFRAME HYDRAULIC TUBING

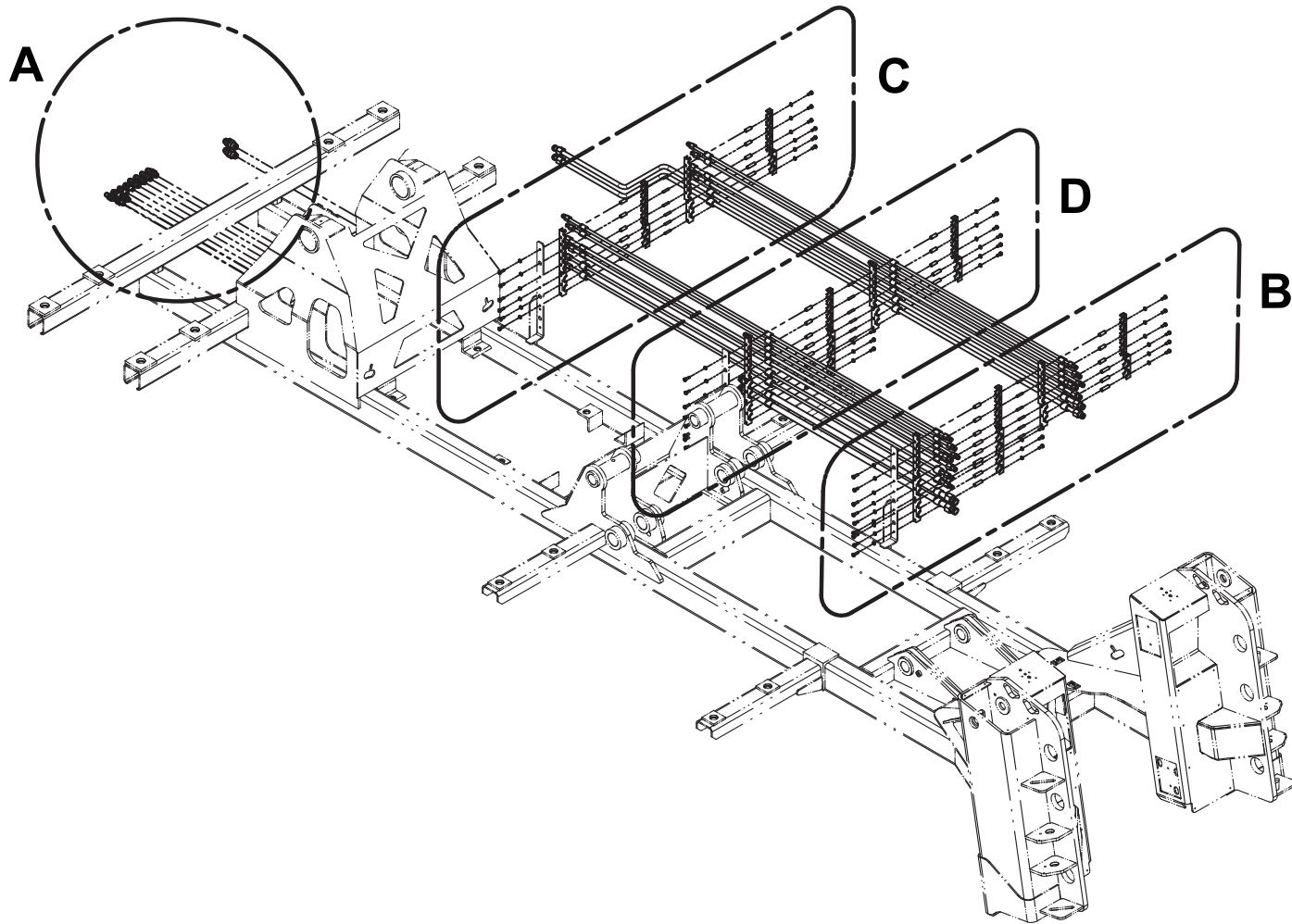

### SUBFRAME HYDRAULIC TUBING

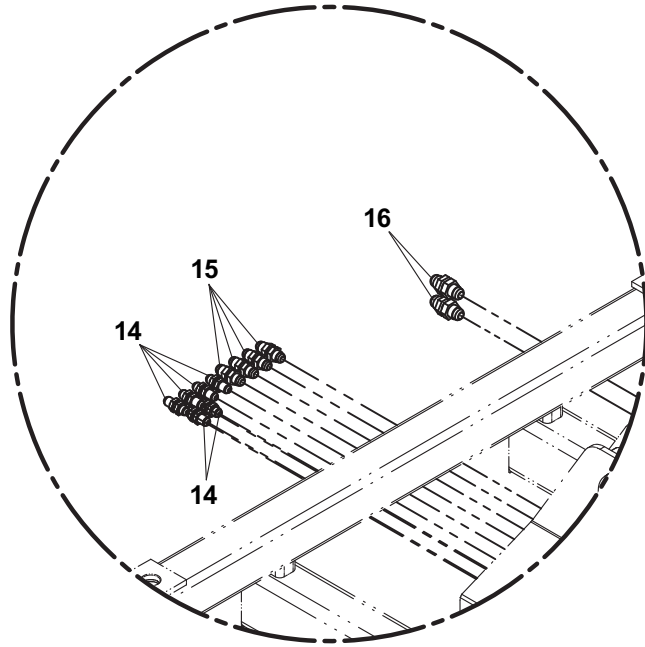

**DETAIL A**  
BULKHEAD FITTINGS

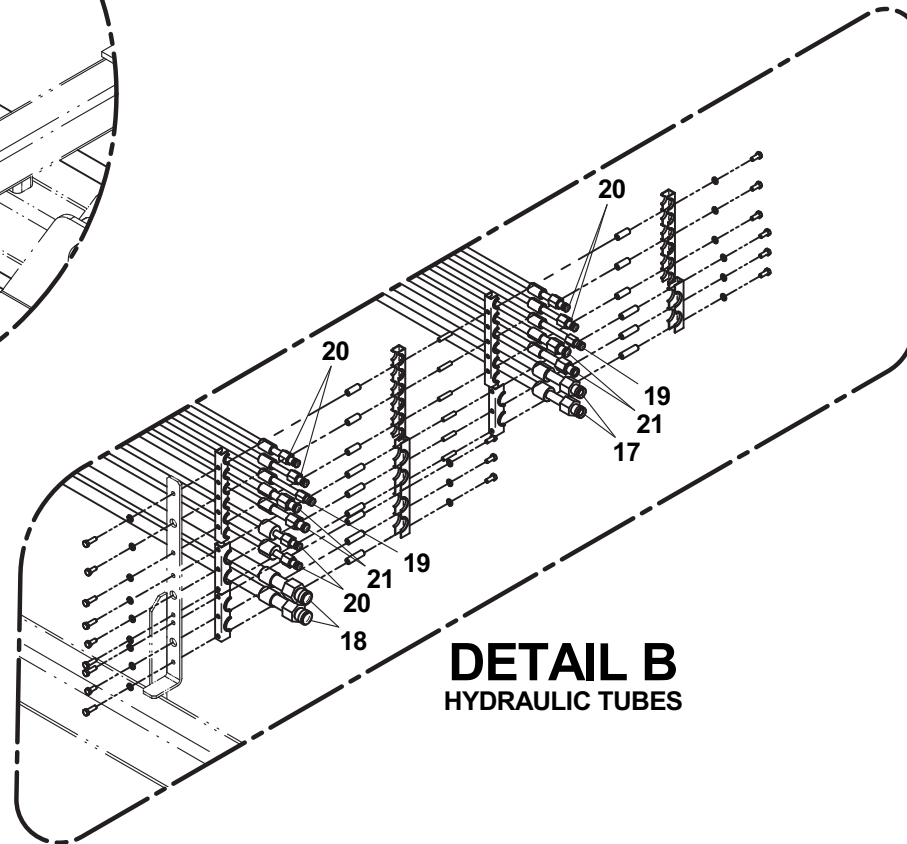

**DETAIL B**  
HYDRAULIC TUBES

# SUBFRAME HYDRAULIC TUBING

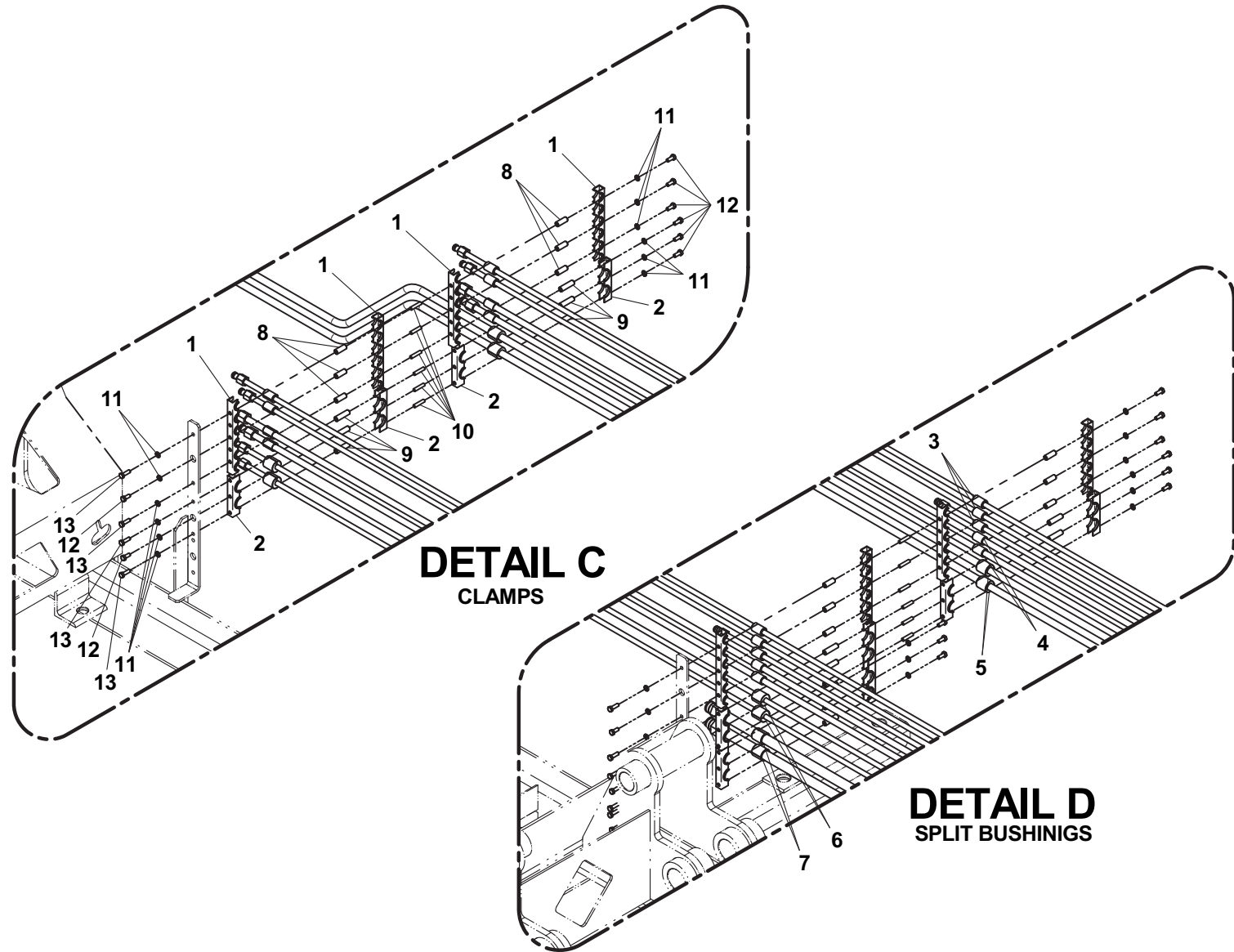

**HYDRAULIC TANK INSTALLATION**

ITEM	PART NO.	DESCRIPTION	QTY
1	3750000022	Hydraulic Tank Assembly	1
2	7115181850	Capscrew, 0.50"-13NC x 2.25"	4
3	7950180141	Flatwasher, 0.50" ID	4
4	7660182601	Locknut, 0.50"-13NC	4
5	7949000015	Washer, Head	4
6	7949000016	Washer, Tail	4
7	7636000006	Rubber Mount	4



# HYDRAULIC TANK INSTALLATION

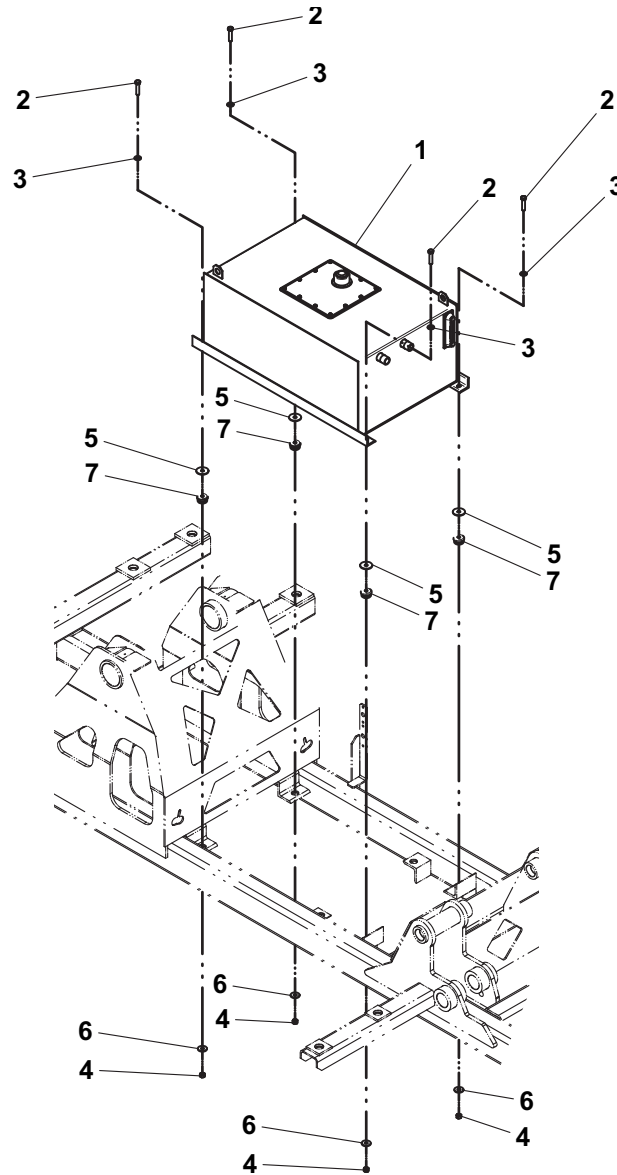

**HYDRAULIC TANK ASSEMBLY**

ITEM	PART NO.	DESCRIPTION	QTY
1	3750000021	Hydraulic Tank	1
2	7183000002	Breather, Filler Cap	1
3	7470000003	Gauge, Sight	1
4	7701000025	Plug, Magnetic	1
5	7796000051	Gasket	1
6	4706002235	Plate	1
7	7115140650	Capscrew, 0.25"-25NC x 0.75"	12
8	7950140000	Lockwasher, 0.25" ID	12
9	7444120014	Plug	1
10	7444160011	Plug	2

# HYDRAULIC TANK ASSEMBLY

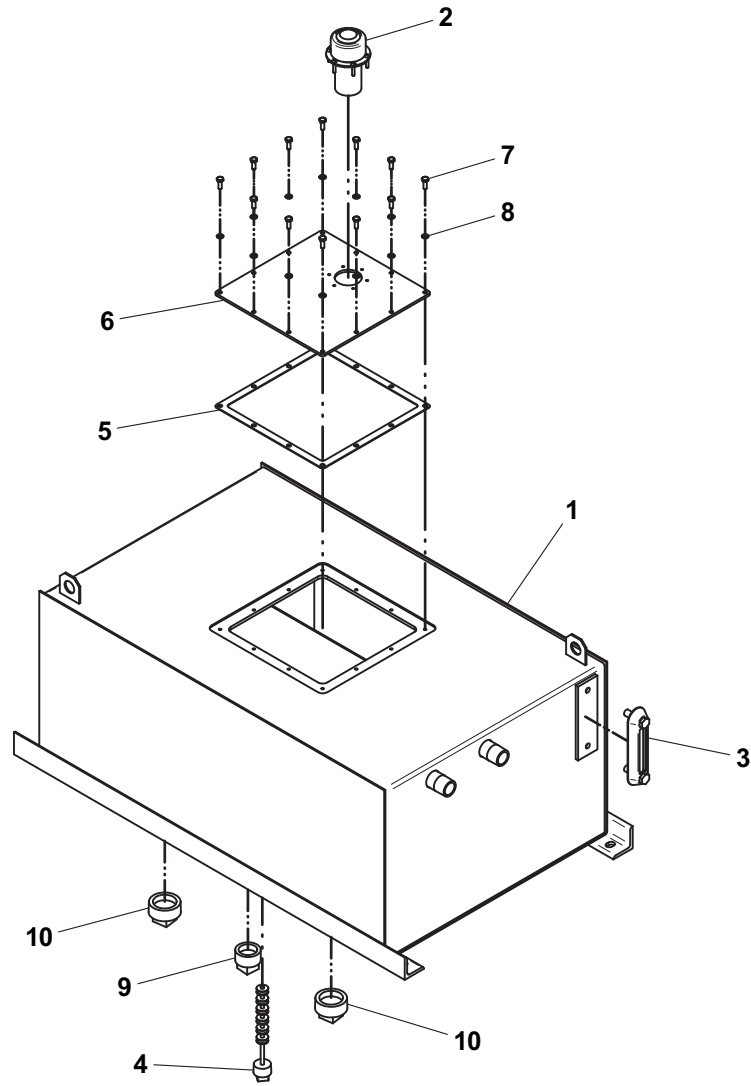

**REAR SPADE INSTALLATION**

ITEM	PART NO.	DESCRIPTION	QTY
1	7115161250	Capscrew, 0.38"-16NC x 1.50"	2
2	7950160161	Flatwasher, 0.38" ID	2
3	7660162601	Locknut, 0.38"-16NC	2
4	3691000267	Pin	2
5	4706003716	Plate	2
6	7114140518	Capscrew, 0.25"-20NC x 0.63"	8
7	7949000025	Lockwasher, 11MM ID	8
8	7950140153	Flatwasher, 0.25" ID	8
9	7320000006	Spade Cylinder Assembly	2
10	3263000061	Channel, Spade - RH	1
11	3263000062	Channel, Spade - LH	1
12	4691000207	Pin	2
13	7754000033	Retaining Ring	4
14	4691000200	Pin	2
15	7754000008	Retaining Ring	4
16	3691000126	Pin	2
17	7691000019	Lynch Pin	2
18	3706000335	Spade Claw Plate	2
19	7440030000	Grease Fitting	2

# REAR SPADE INSTALLATION

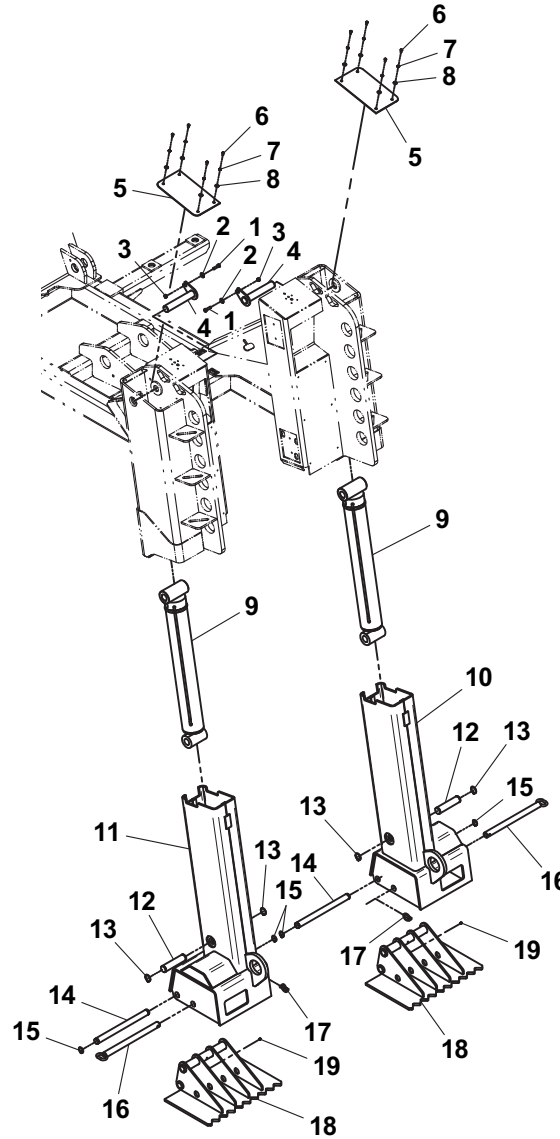

**REAR SPADE TUBING**

ITEM	PART NO.	DESCRIPTION	QTY
1	7912000245	Tube Assembly	1
2	7912000246	Tube Assembly	1
3	7912000247	Tube Assembly	1
4	7912000248	Tube Assembly	1
5	7274000050	Clamp	5
6	7274000064	Clamp	1

# REAR SPADE TUBING

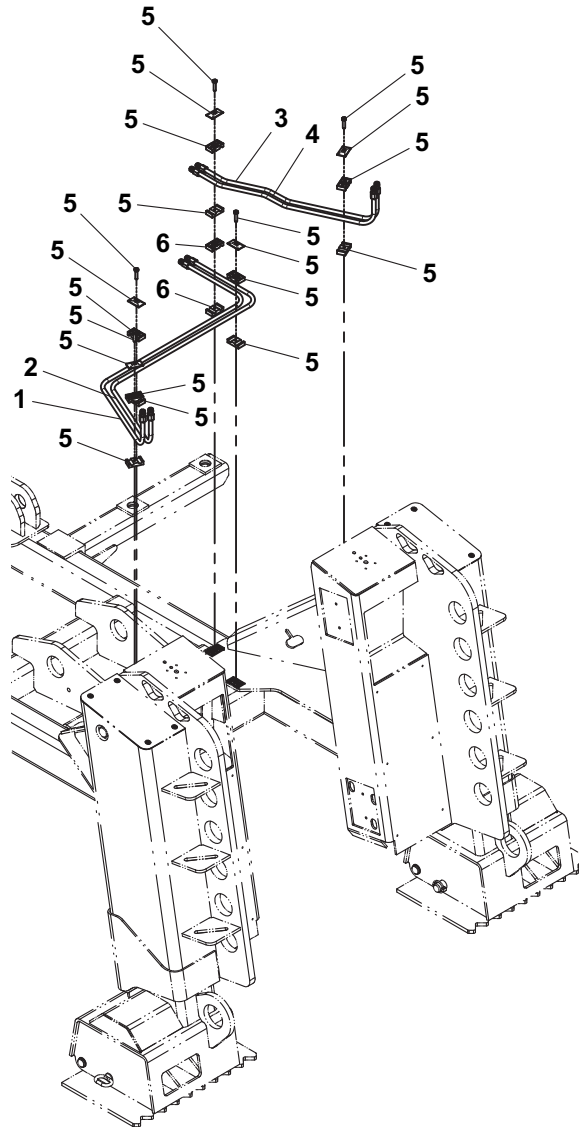

**BOOM INSTALLATION - 2 PIECE BOOM**

ITEM	PART NO.	DESCRIPTION	QTY
1	3170000471	Boom Assembly	1
2	3691000274	Pin	1
3	7754000059	Retaining Ring	1
4	7950180000	Lockwasher, 0.59" ID	4
5	3691000149	Pin	2
6	7115181850	Capscrew, 0.50"-13NC x 2.25"	2
7	7320000084	Lift Cylinder Assembly	2
8	3691000148	Pin	2
9	7115181450	Capscrew, 0.50"-13NC x 1.75"	2
10	7440030000	Grease Fitting	5
11	4949000059	Shim, 0.062" Thick	2
	4949000060	Shim, 0.125" Thick	
12	7253000002	Cap, Grease Fitting	5
13	4679000127	Pad	4
14	7115160623	Capscrew, 0.38"-16NC x 0.75"	8



## BOOM INSTALLATION - 2 PIECE BOOM

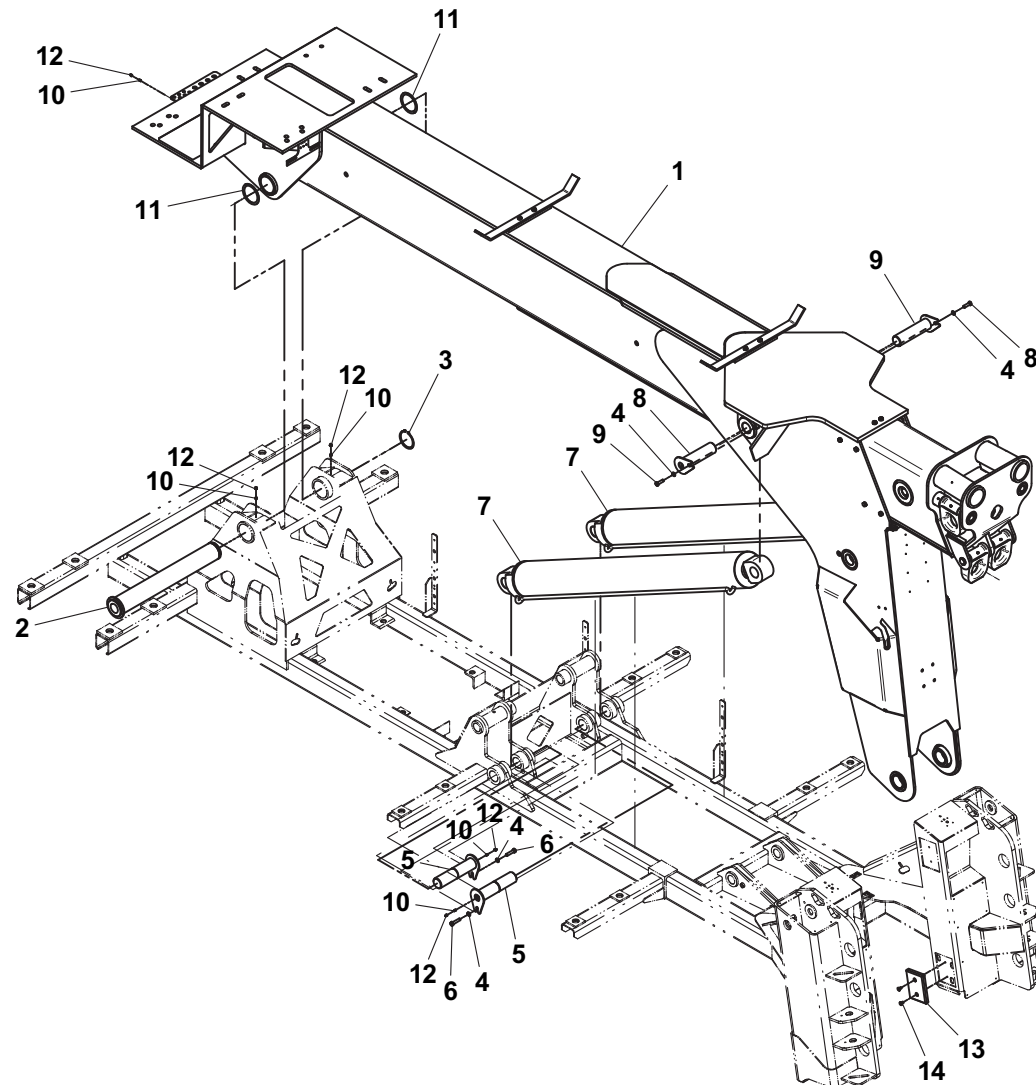

**WRECKER BOOM ASSEMBLY - 2 PIECE BOOM**

ITEM	PART NO.	DESCRIPTION	QTY
1	3170000494	Base Section Boom Weldment	1
2	3170000468	Fly Section Boom Weldment	1
3	7320000028	Extension Cylinder Assembly	1
4	4691000417	Pin	1
5	7754000055	Retaining Ring	4
6	7440030000	Grease Fitting	6
7	7253000002	Cap, Grease Fitting	6
8	4679000140	Pad	4
9	7950140000	Lockwasher, 0.25" ID	4
10	7790141251	Capscrew, 0.25"-20NC x 0.75"	4
11	4691000280	Pin	1
12	4178000811	Bracket	4
13	7115181250	Capscrew, 0.50"-13NC x 1.50"	2
14	4679000314	Pad	4
15	7950180000	Lockwasher, 0.59" ID	18
16	7108180850	Capscrew, 0.50"-13NC x 1.00"	8
17	4706006132	Plate	1
18	7115181650	Capscrew, 0.50"-13NC x 2.00"	4
19	4754000004	D-Ring	4
20	4691000285	Pin	2
21	7690144840	Pin, Spring	2
22	4691000510	Pin	1
23	7754000014	Retaining Ring	2
24	4062000714	Bar	2
25	4679000315	Pad	1
26	7115141250	Capscrew, 0.25"-20NC x 1.50"	3
27	7660142600	Locknut, 0.25"-20NC	5
28	7114141218	Capscrew, 0.25"-20NC x 1.50"	2
29	4062000158	Bar	2
30	7115180850	Capscrew, 0.50"-13NC x 1.00"	4
31	4062000715	Bar	1
32	3561000017	Hook	2
33	7115161050	Capscrew, 0.38"-16NC x 1.25"	4
34	7950160141	Flatwasher, 0.38" ID	4

# WRECKER BOOM ASSEMBLY - 2 PIECE BOOM

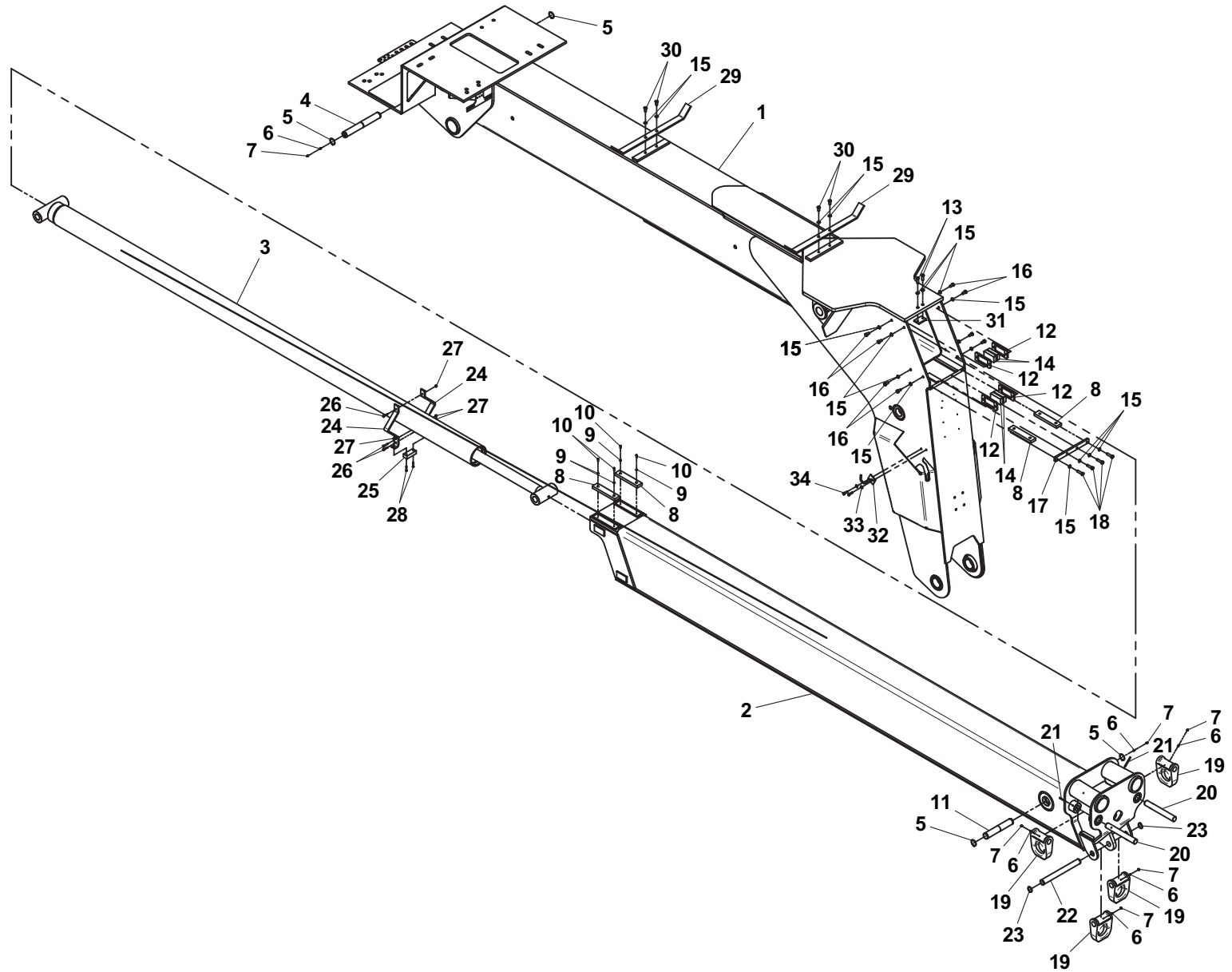

**BOOM INSTALLATION - 3 PIECE BOOM**

ITEM	PART NO.	DESCRIPTION	QTY
1	3170000486	Boom Assembly	1
2	7320000084	Lift Cylinder Assembly	2
3	3691000274	Pin	1
4	3691000149	Pin	2
5	3691000148	Pin	2
6	7754000059	Retaining Ring	1
7	7440030000	Grease Fitting	5
8	7253000002	Cap, Grease Fitting	5
9	7950180000	Lockwasher, 0.59" ID	4
10	7115181850	Capscrew, 0.50"-13NC x 2.25"	2
11	7115181450	Capscrew, 0.50"-13NC x 1.75"	2
12	4949000059	Shim, 0.062" Thick	2
	4949000060	Shim, 0.125" Thick	

## BOOM INSTALLATION - 3 PIECE BOOM

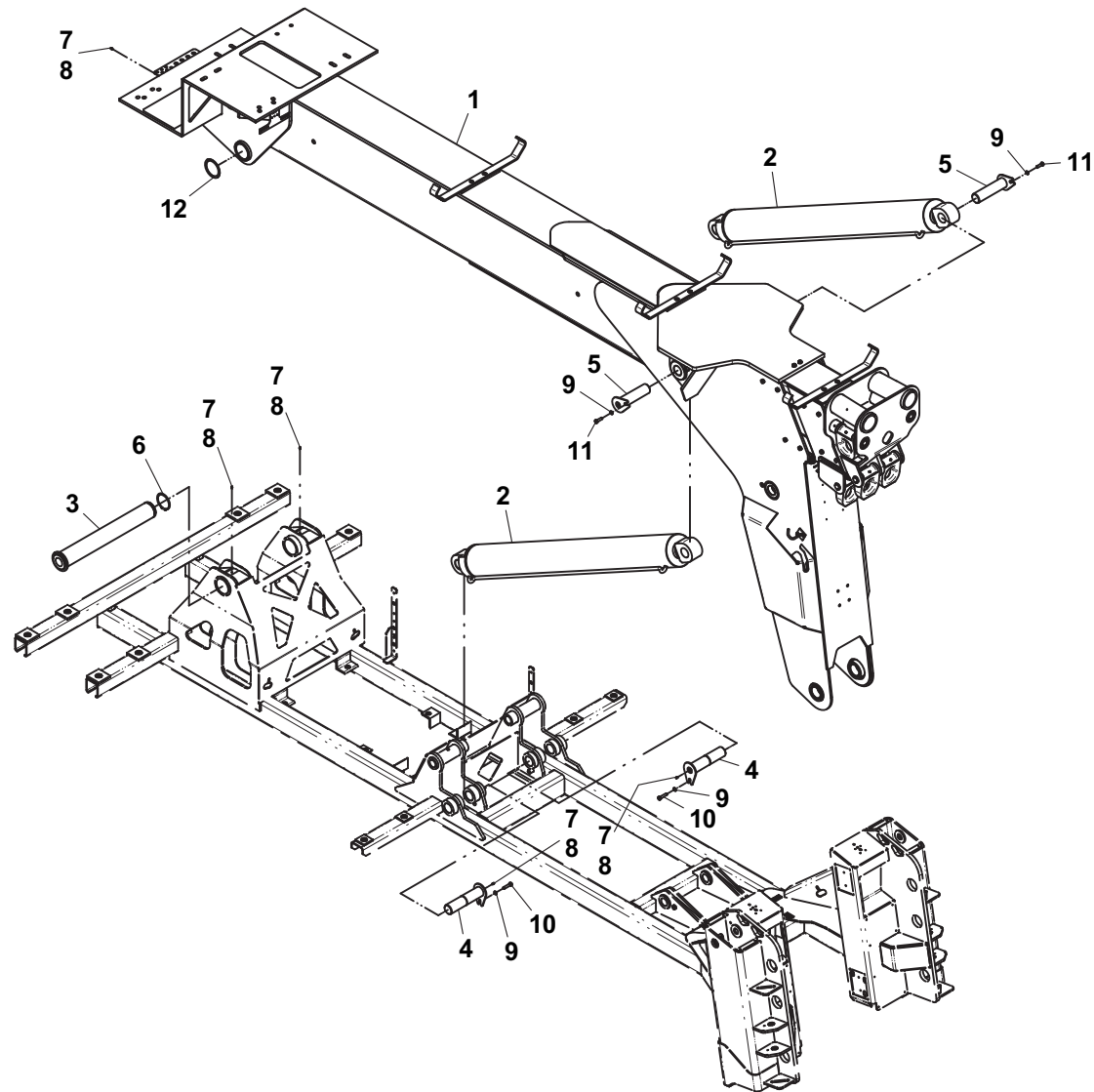

**WRECKER BOOM ASSEMBLY - 3 PIECE BOOM**

ITEM	PART NO.	DESCRIPTION	QTY	ITEM	PART NO.	DESCRIPTION	QTY
1	3170000494	Base Section Boom Weldment	1	36	4178000857	Bracket	2
2	4178000811	Bracket	8	37	4178000872	Bracket	2
3	4679000314	Pad	6	38	7115160650	Capscrew, 0.38"-16NC x 0.75"	4
4	4679000313	Pad	2	39	7950160000	Lockwasher, 0.38" ID	4
5	4679000140	Pad	8	40	7115143250	Capscrew, 0.25"-20NC x 4.00"	2
6	4706006132	Plate	1	41	7950140141	Flatwasher, 0.25" ID	4
7	3170000484	Mid Section Boom Weldment	1	42	7843000048	Spring, Extension	2
8	3706000241	Plate Weldment	2	43	7253000002	Cap, Grease Fitting	8
9	4062000715	Bar	1	44	3561000017	Hook	2
10	4754000004	D-Ring	6	45	7115161050	Capscrew, 0.38"-16NC x 1.25"	4
11	4062000746	Bar	3	46	7950160141	Flatwasher, 0.38" ID	4
12	3170000483	Fly Section Boom Weldment	1				
13	4706006182	Plate	1				
14	7320000085	Extension Cylinder Assembly	1				
15	4691000417	Pin	1				
16	4691000510	Pin	2				
17	7754000014	Retaining Ring	4				
18	4691000285	Pin	2				
19	7690144840	Pin, Spring	2				
20	7440030000	Grease Fitting	8				
21	7950180000	Lockwasher, 0.59" ID	26				
22	7115180723	Capscrew, 0.50"-13NC x 0.88"	6				
23	7754000055	Retaining Ring	4				
24	7115181250	Capscrew, 0.50"-13NC x 1.50"	2				
25	7108180850	Capscrew, 0.50"-13NC x 1.00"	16				
26	7120000040	Bolt, 0.75"-10NC x 2.00"	8				
27	7950140000	Lockwasher, 0.25" ID	16				
28	7118140427	Capscrew, 0.25"-20NC x 0.50"	8				
29	4691000416	Pin	1				
30	7115181650	Capscrew, 0.50"-13NC x 2.00"	8				
31	4679000326	Pad	2				
32	4679000319	Pad	2				
33	7114141218	Capscrew, 0.25"-20NC x 1.50"	4				
34	7660142601	Locknut, 0.25"-20NC	6				
35	7114141618	Capscrew, 0.25-20NC x 2.00"	4				

# WRECKER BOOM ASSEMBLY - 3 PIECE BOOM

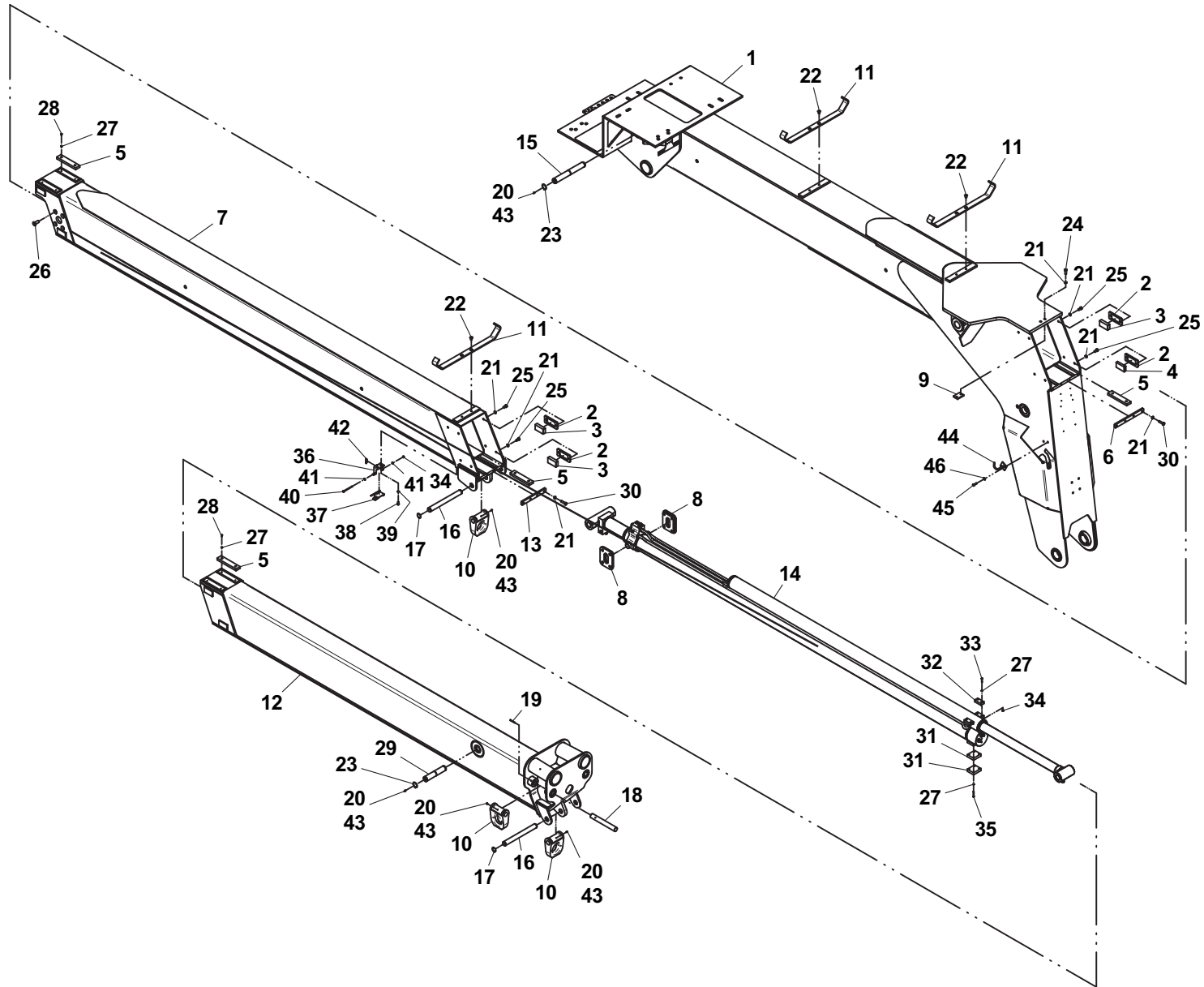

**WINCH INSTALLATION - 50K DP PLANETARY 2 SPEED MOTOR SHIFT (STANDARD)**

ITEM	PART NO.	DESCRIPTION	QTY
1	7970000168	Winch	1
2	7970000169	Winch	1
3	3178000575	Bracket, Winch Mount	4
4	3178000576	Bracket, Winch Mount	4
5	7253000002	Cap, Grease Fitting	2
6	7118222816	Capscrew, 0.75"-10NC x 3.50"	16
7	7660222308	Locknut, 0.75"-10NC	32
8	7118221616	Capscrew, 0.75"-10NC x 2.00"	16
9	7754000059	Retaining Ring	2
10	7440030000*	Grease Fitting	4
11	3249000008*	Sheave Support Weldment	2
12	3249000035*	Cable Guide Weldment	2
13	7809000004*	Sheave	2
14	7754000033*	Retaining Ring	2
15	3691000151*	Pin	2
16	7115182650*	Capscrew, 0.50"-13NC x 3.25"	6
17	7950180141*	Flatwasher, 0.50" ID	12
18	7660182601*	Locknut, 0.50"-13NC	6
19	4831000104*	Spacer	6
20	7115181450	Capscrew, 0.50"-13NC x 1.75"	4
21	7950180150	Flatwasher, 0.50" ID	4
22	7660182601	Locknut, 0.50"-13NC	4
23	3178000546+	Bracket, Cable Tie- Back	1
24	7189000014+	Spring	4
25	4831000115+	Spacer	4
26	7120000053+	Ring Bolt, 0.50"-13NC	2
27	7660182601+	Locknut, 0.50"-13NC	2
28	7577000573	Kit, Hydraulic Hose	1

\* Available in Sheave Head Assembly - 3249000009

+ Available in Cable Tie-Back Assembly - 3249000047



# WINCH INSTALLATION - 50K DP PLANETARY 2 SPEED MOTOR SHIFT (STANDARD)

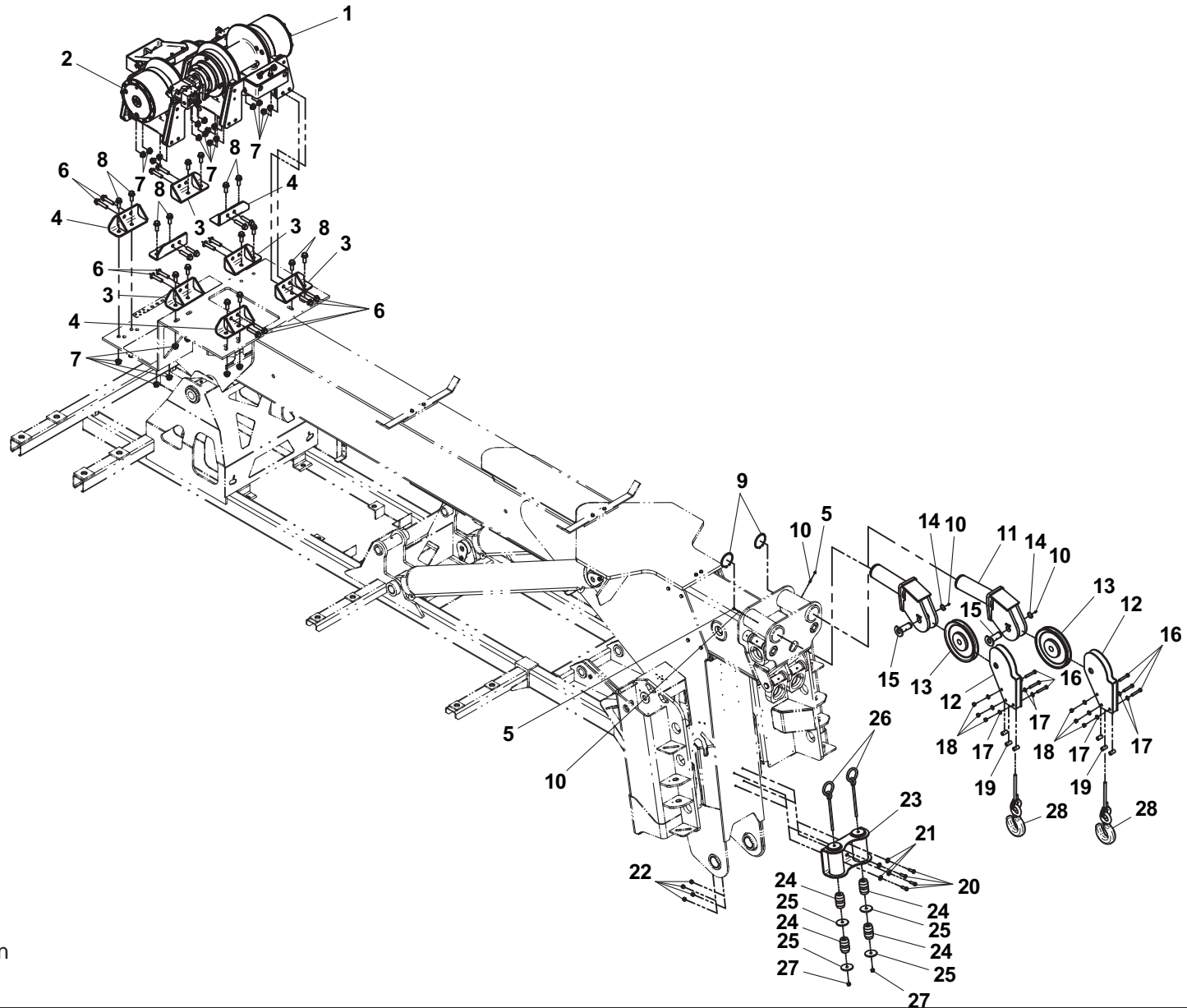

**WINCH INSTALLATION - 50K DP PLANETARY 2 SPEED GEAR SHIFT (OPTIONAL)**

ITEM	PART NO.	DESCRIPTION	QTY
1	7970000059	Winch	1
2	7970000060	Winch	1
3	3178000575	Bracket, Winch Mount	4
4	3178000576	Bracket, Winch Mount	4
5	7253000002	Cap, Grease Fitting	2
6	7118222816	Capscrew, 0.75"-10NC x 3.50"	16
7	7660222308	Locknut, 0.75"-10NC	32
8	7118221616	Capscrew, 0.75"-10NC x 2.00"	16
9	7754000059	Retaining Ring	2
10	7440030000*	Grease Fitting	4
11	3249000008*	Sheave Support Weldment	2
12	3249000035*	Cable Guide Weldment	2
13	7809000004*	Sheave	2
14	7754000033*	Retaining Ring	2
15	3691000151*	Pin	2
16	7115182650*	Capscrew, 0.50"-13NC x 3.25"	6
17	7950180141*	Flatwasher, 0.50" ID	12
18	7660182601*	Locknut, 0.50"-13NC	6
19	4831000104*	Spacer	6
20	7115181450	Capscrew, 0.50"-13NC x 1.75"	4
21	7950180150	Flatwasher, 0.50" ID	4
22	7660182601	Locknut, 0.50"-13NC	4
23	3178000546+	Bracket, Cable Tie- Back	1
24	7189000014+	Spring	4
25	4831000115+	Spacer	4
26	7120000053+	Ring Bolt, 0.50"-13NC	2
27	7660182601+	Locknut, 0.50"-13NC	2
28	7577000574	Kit, Hydraulic Hose	1

\* Available in Sheave Head Assembly - 3249000009

+ Available in Cable Tie-Back Assembly - 3249000047

# WINCH INSTALLATION - 50K DP PLANETARY 2 SPEED GEAR SHIFT (OPTIONAL)

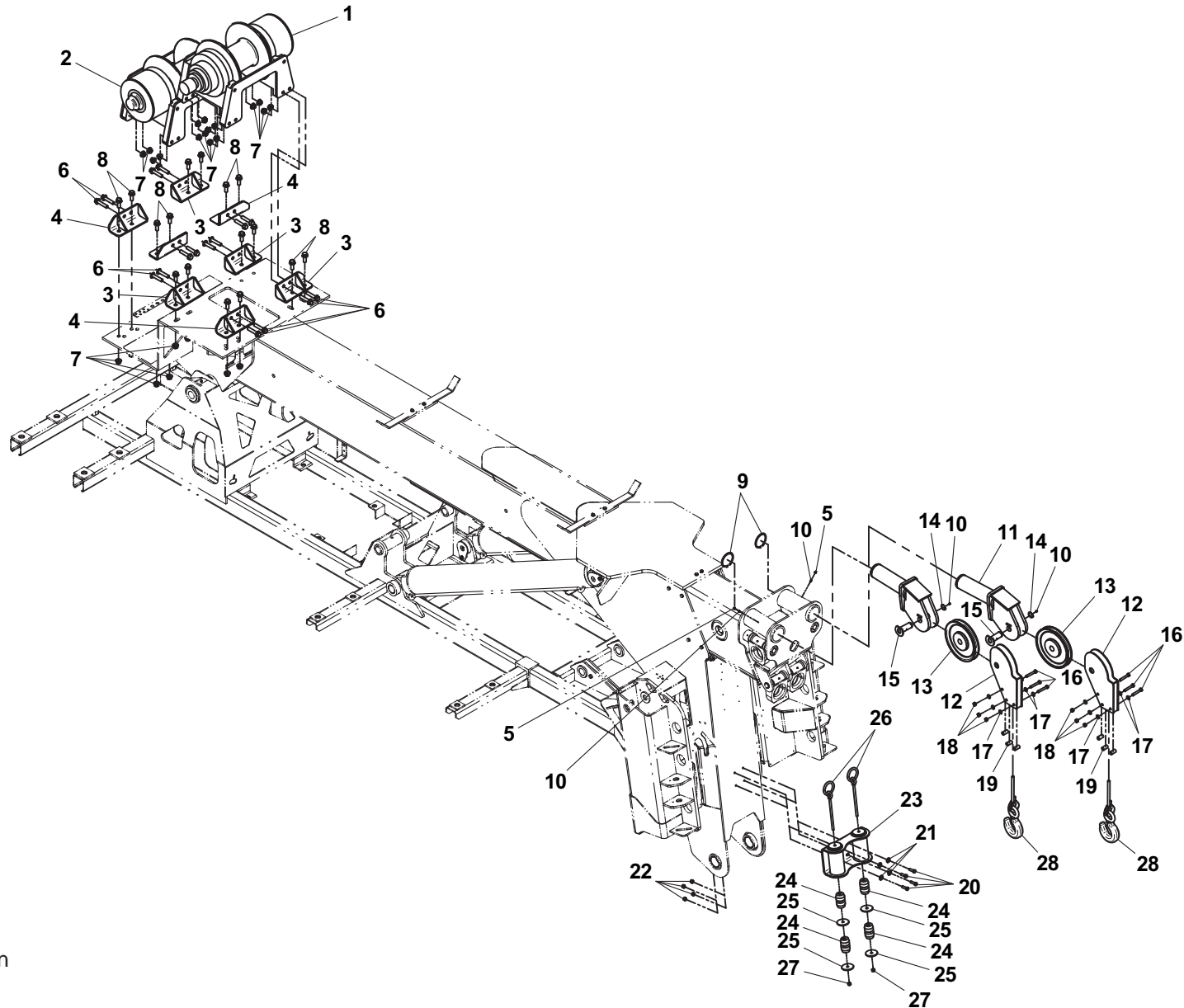

Item #28, not shown

**WINCH INSTALLATION - 50K RAMSEY PLANETARY 2 SPEED (OPTIONAL)**

ITEM	PART NO.	DESCRIPTION	QTY
1	7970000173	Winch	1
2	7970000174	Winch	1
3	3178000575	Bracket, Winch Mount	4
4	3178000576	Bracket, Winch Mount	4
5	7253000002	Cap, Grease Fitting	2
6	7118222816	Capscrew, 0.75"-10NC x 3.50"	16
7	7660222308	Locknut, 0.75"-10NC	32
8	7118221616	Capscrew, 0.75"-10NC x 2.00"	16
9	7754000059	Retaining Ring	2
10	7440030000*	Grease Fitting	4
11	3249000008*	Sheave Support Weldment	2
12	3249000035*	Cable Guide Weldment	2
13	7809000004*	Sheave	2
14	7754000033*	Retaining Ring	2
15	3691000151*	Pin	2
16	7115182650*	Capscrew, 0.50"-13NC x 3.25"	6
17	7950180141*	Flatwasher, 0.50" ID	12
18	7660182601*	Locknut, 0.50"-13NC	6
19	4831000104*	Spacer	6
20	7115181450	Capscrew, 0.50"-13NC x 1.75"	4
21	7950180150	Flatwasher, 0.50" ID	4
22	7660182601	Locknut, 0.50"-13NC	4
23	3178000546+	Bracket, Cable Tie- Back	1
24	7189000014+	Spring	4
25	4831000115+	Spacer	4
26	7120000053+	Ring Bolt, 0.50"-13NC	2
27	7660182601+	Locknut, 0.50"-13NC	2
28	7577000574	Kit, Hydraulic Hose	1

\* Available in Sheave Head Assembly - 3249000009

+ Available in Cable Tie-Back Assembly - 3249000047

# WINCH INSTALLATION - 50K RAMSEY PLANETARY 2 SPEED (OPTIONAL)

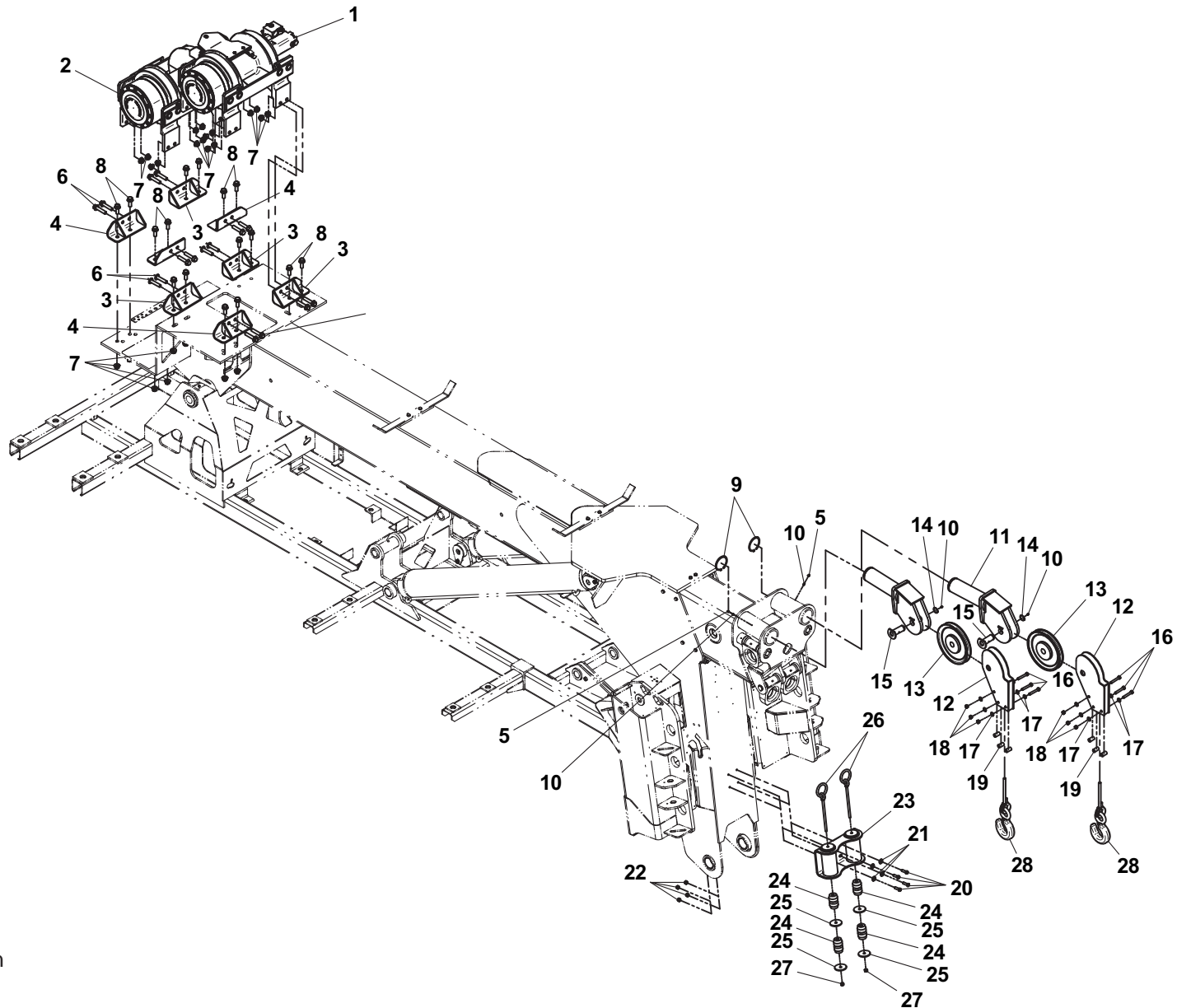

Item #28, not shown

**BOOM TUBE ASSEMBLY**

ITEM	PART NO.	DESCRIPTION	QTY
1	7912000345*	Tube Assembly	4
2	7912000344*	Tube Assembly	1
3	7912000343*	Tube Assembly	1
4	7274000030	Clamp Unit	10
5	7661000022	Nut, 0.31"-18NC Stacking Head	10
6	7950150000	Lockwasher, 0.31" ID	10
7	7115150650	Capscrew, 0.31"-18NC x 0.75"	10
8	7115151650	Capscrew, 0.31"-18NC x 2.00"	5
9	7660152601	Locknut, 0.31"-18NC	5
10	7209000023	Bushing, 0.50" ID	20
11	7274000060	Clamp	6

\* Available in Hydraulic Tubing Kit - 7577000564

# BOOM TUBE ASSEMBLY

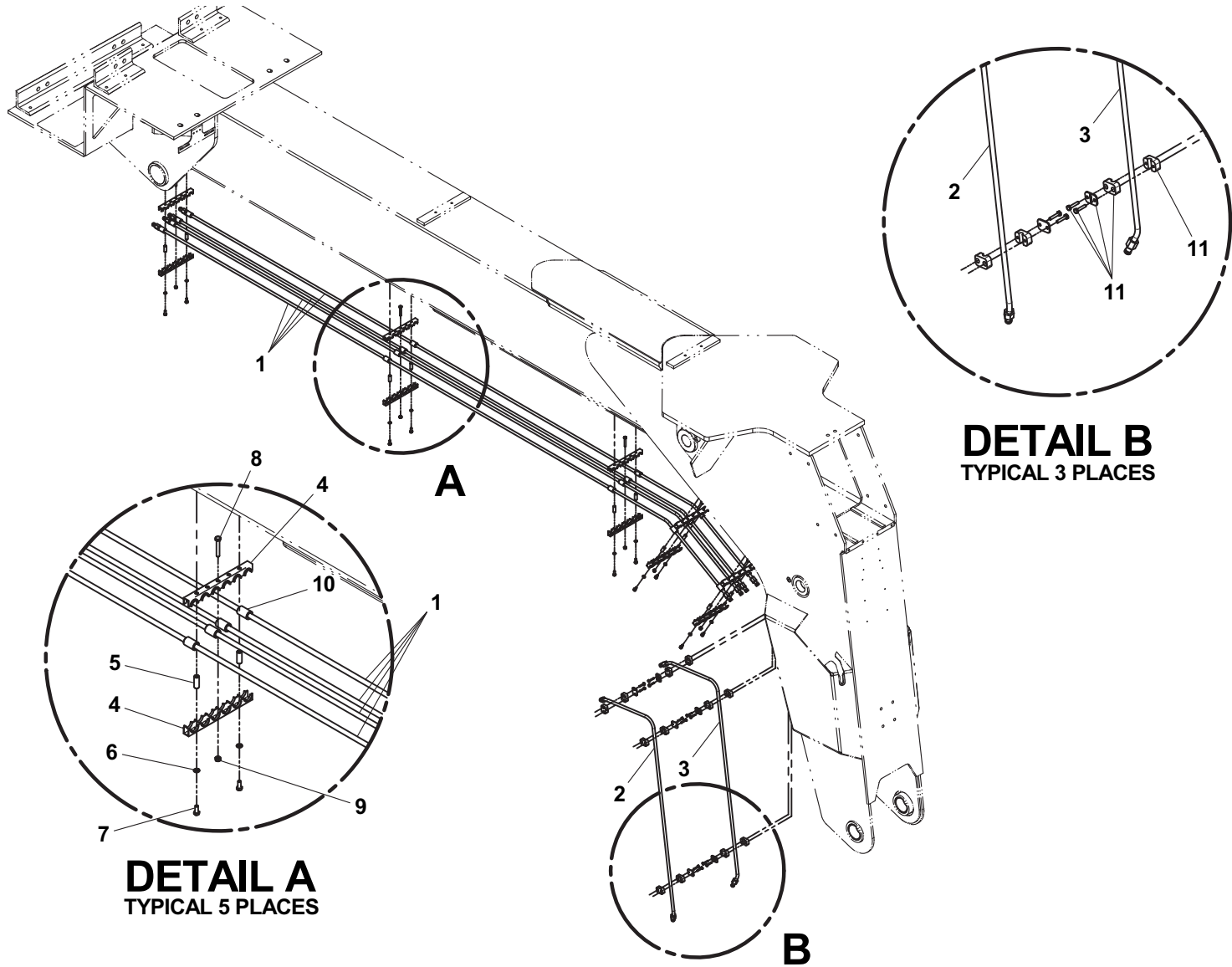

**DETAIL A**  
TYPICAL 5 PLACES

**DETAIL B**  
TYPICAL 3 PLACES

**UNDERLIFT INSTALLATION - 53,000 LB (STANDARD)**

ITEM	PART NO.	DESCRIPTION	QTY
1	732000047	Underlift Tilt Cylinder Assembly	1
2	4691000291	Pin	1
3	7754000018	Retaining Ring	2
4	3691000154	Pin	1
5	4691000290	Pin	1
6	7754000051	Retaining Ring	2
7	7115180750	Capscrew, 0.50"-13NC x 0.88"	1
8	7590180161	Flatwasher, 0.50" ID	1
9	7950180000	Lockwasher, 0.50" ID	1
10	7440030000	Grease Fitting	3
11	7262000025	Chain	2
12	7118201250	Capscrew, 0.63"-11NC x 1.50"	2
13	7660202601	Locknut, 0.63-11NC	2
14	7209000029	Bushing	2
15	3507100001	Underlift Assembly	1



## UNDERLIFT INSTALLATION - 53,000 LB (STANDARD)

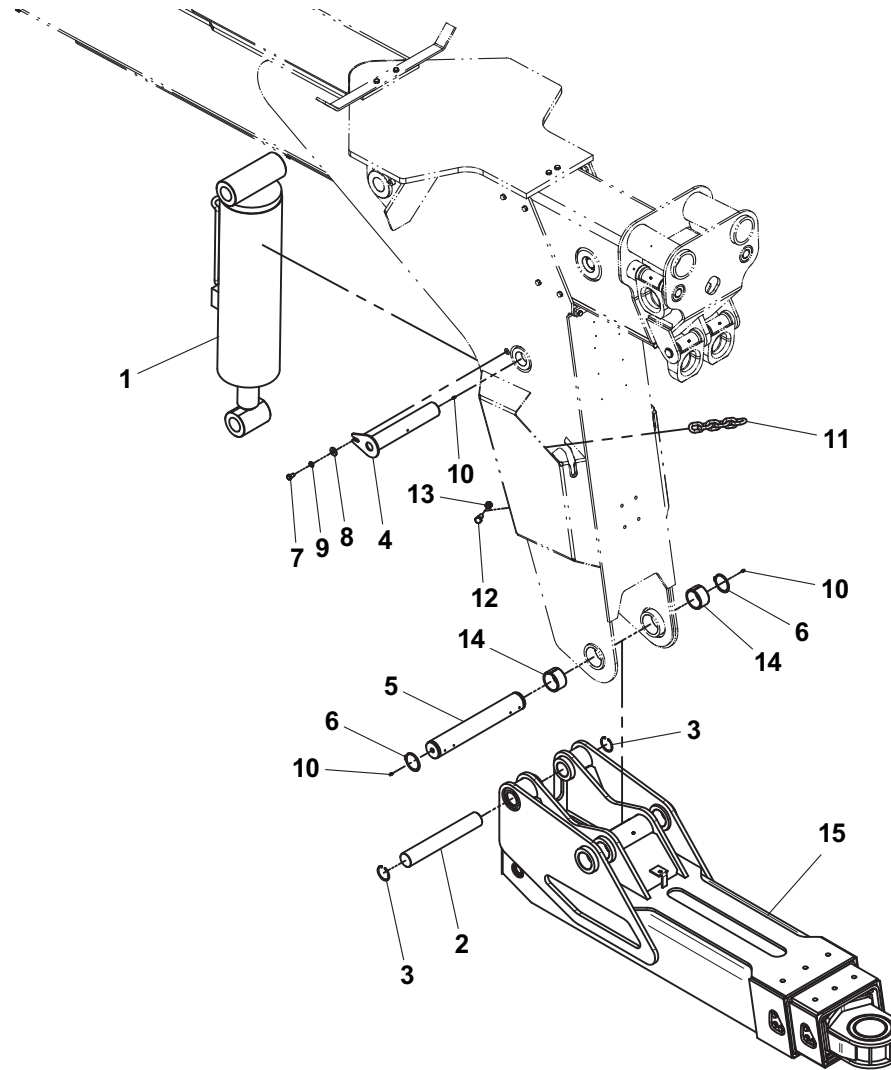

**UNDERLIFT INSTALLATION - 56,500 LB (OPTIONAL)**

ITEM	PART NO.	DESCRIPTION	QTY
1	732000079	Underlift Tilt Cylinder Assembly	1
2	4691000291	Pin	1
3	7754000018	Retaining Ring	2
4	3691000154	Pin	1
5	4691000290	Pin	1
6	7754000051	Retaining Ring	2
7	7115180750	Capscrew, 0.50"-13NC x 0.88"	1
8	7590180161	Flatwasher, 0.50" ID	1
9	7950180000	Lockwasher, 0.50" ID	1
10	7440030000	Grease Fitting	3
11	7262000025	Chain	2
12	7118201250	Capscrew, 0.63"-11NC x 1.50"	2
13	7660202601	Locknut, 0.63-11NC	2
14	7209000029	Bushing	2
15	3317000407	Underlift Assembly	1

# UNDERLIFT INSTALLATION - 56,500 LB (OPTIONAL)

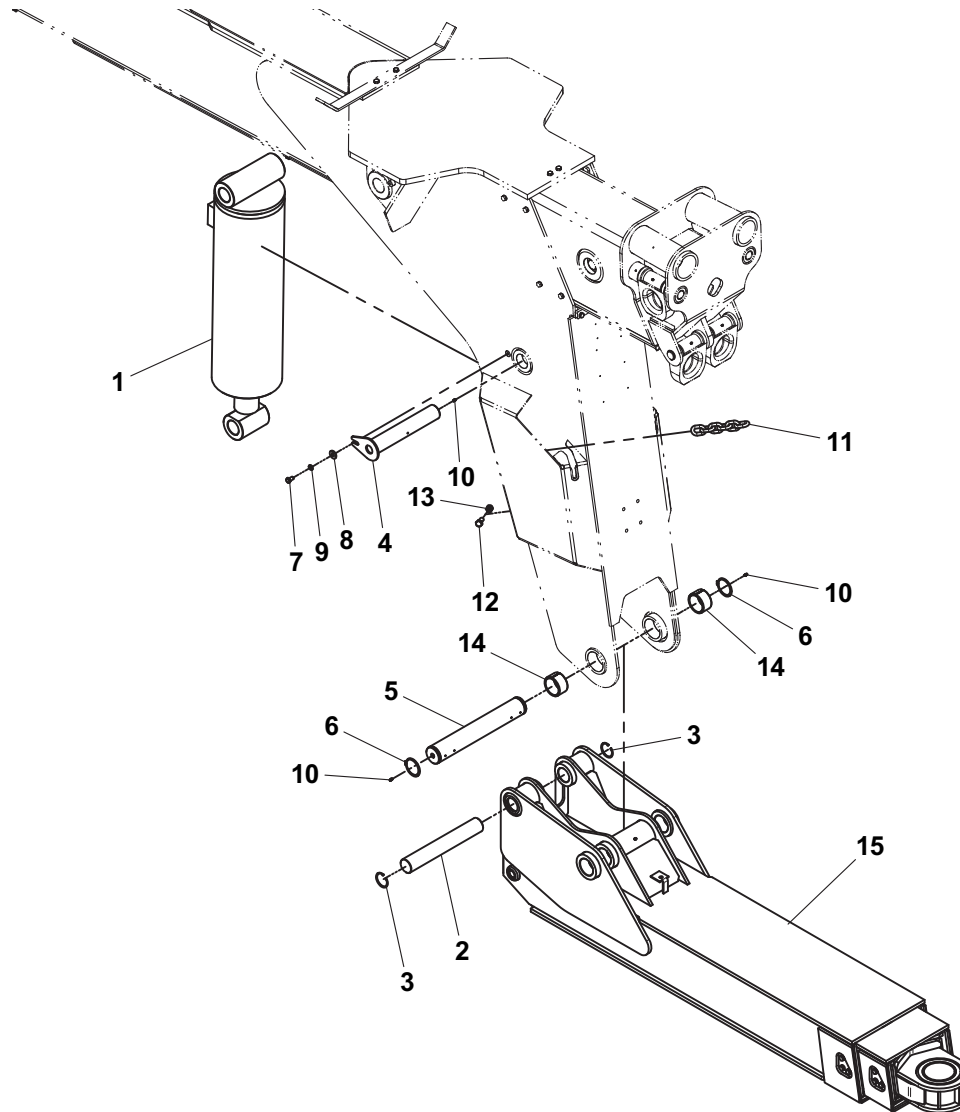

**UNDERLIFT ASSEMBLY - 3507100001 - 53,000 LB (STANDARD)**

ITEM	PART NO.	DESCRIPTION	QTY
1	3170000125	Base Section Boom Weldment	1
2	3170000124	Mid Section Boom Weldment	1
3	3170000123	Fly Section Boom Weldment	1
4	7320000026	Underlift Extension Cylinder Assembly	1
5	4691000292	Pin	1
6	4691000293	Pin	1
7	7754000043	Retaining Ring	4
8	4679000146	Pad	8
9	4679000147	Pad	2
10	7114140518	Capscrew, 0.25"-20NC x 0.63"	10
11	4706002209	Plate	1
12	7108181050	Capscrew, 0.50"-20NF x 1.25"	6
13	4706002208	Plate	1
14	7108180850	Capscrew, 0.50"-20NF x 1.00"	6
15	7950180153	Flatwasher, 0.50" ID	12
16	7440030000	Grease Fitting	1
17	4706002207	Plate	1
18	7115140650	Capscrew, 0.25"-20NC x 0.75"	4
19	7950140000	Lockwasher, 0.25" ID	4
20	4706002211	Plate	1
21	4706002210	Plate	1
22	4812000057	Shim, 14GA	2
23	4706003708	Plate	2
24	4706003709	Plate	2
25	4706003710	Plate	4
26	4706003717	Plate	8
27	4706003718	Plate	8

# UNDERLIFT ASSEMBLY - 3507100001 - 53,000 LB (STANDARD)

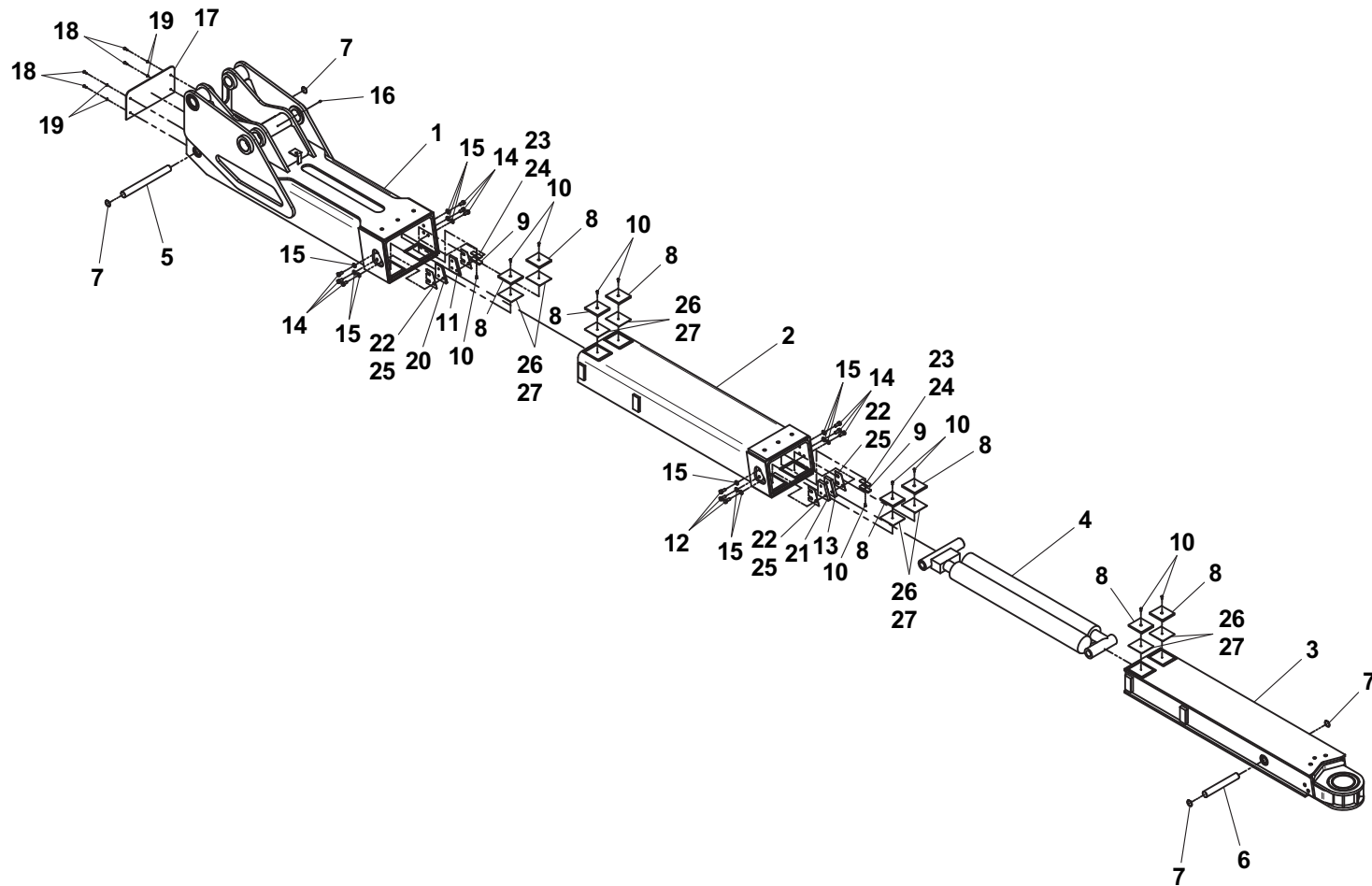

**UNDERLIFT ASSEMBLY - 3170000407 - 56,500 LB (OPTIONAL)**

ITEM	PART NO.	DESCRIPTION	QTY
1	3170000400	Base Section Boom Weldment	1
2	3170000401	Mid Section Boom Weldment	1
3	3170000406	Fly Section Boom Weldment	1
4	7320000068	Underlift Extension Cylinder Assembly	1
5	4691000293	Pin	1
6	4691000321	Pin	1
7	7754000043	Retaining Ring	4
8	4706005262	Plate	2
9	4706005263	Plate	2
10	7108180850	Capscrew, 0.50"-20NF x 1.00"	12
11	7950180000	Lockwasher, 0.50" ID	12
12	4679000277	Pad, 0.38 Thk	8
	4679000293	Pad, 0.25 Thk	
13	7114140518	Capscrew, 0.25"-20NC x 0.63"	8
14	4706005281	Plate	1
15	7661000019	U-Nut, 0.25"-20NC	4
16	7115140650	Capscrew, 0.25"-20NC x 0.75"	4
17	7950140000	Lockwasher, 0.25" ID	4
18	7440030000	Grease Fitting	1

# UNDERLIFT ASSEMBLY - 3170000407 - 56,500 LB (OPTIONAL)

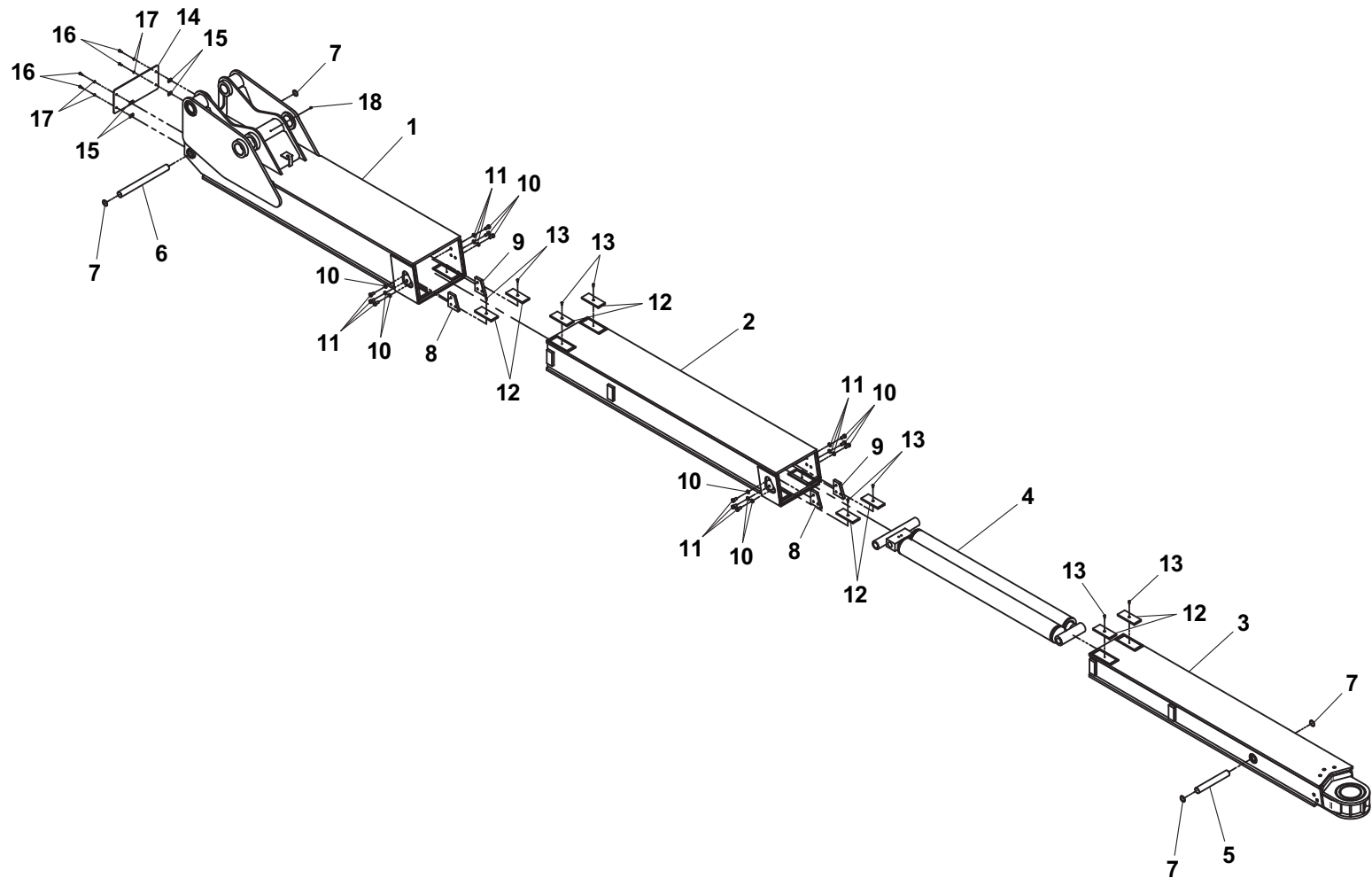

**CROSSTUBE INSTALLATION**

ITEM	PART NO.	DESCRIPTION	QTY
1	3913000094	Crosstube Weldment	1
2	4691000242	Pin	1
3	7754000042	Retaining Ring	1
4	7440300000	Grease Fitting	1
5	7209000022	Bushing	1
6	4949000041*	Washer, 0.125" Thk	1
7	4949000042*	Washer, 0.63" Thk	2

\* Available in Shim Kit - 3577000018



## CROSSTUBE INSTALLATION

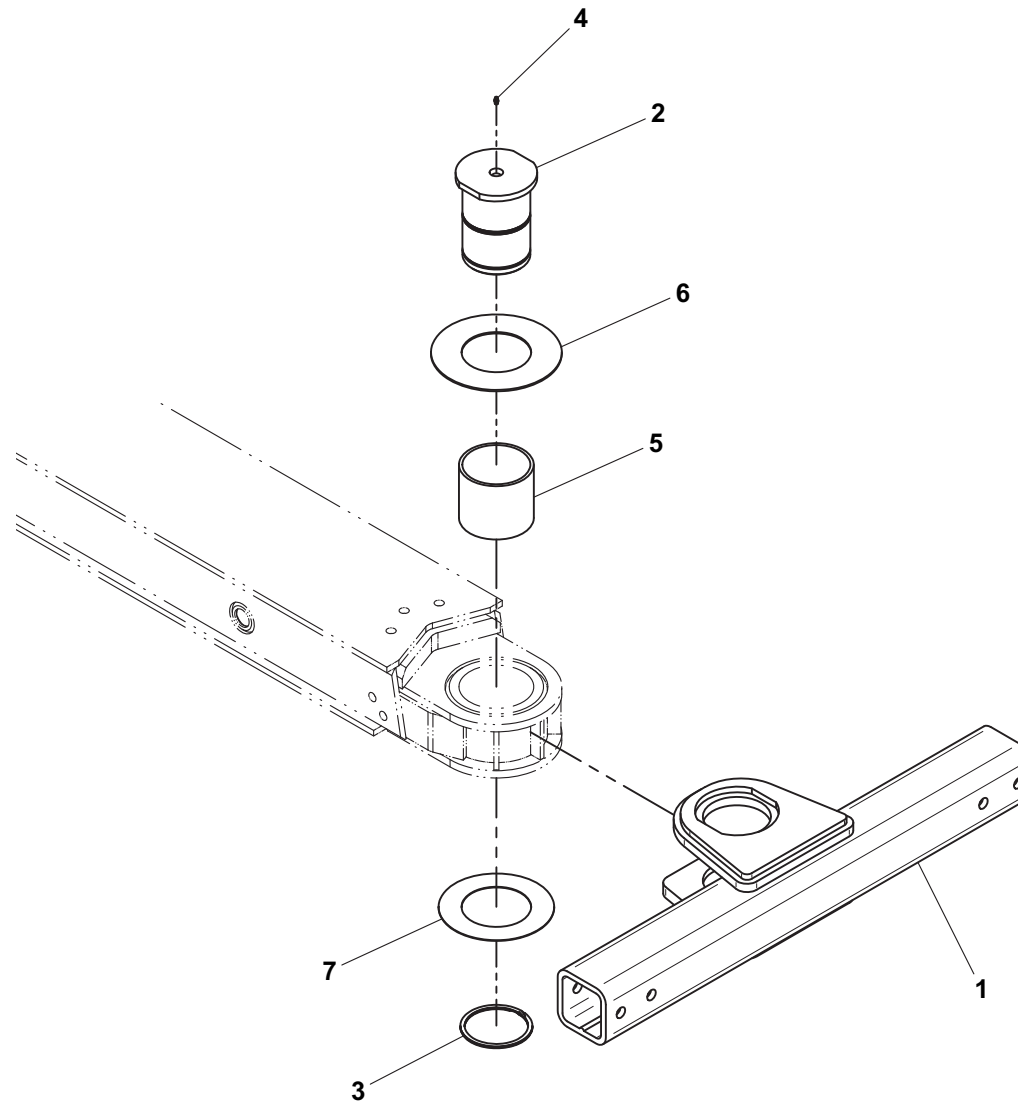

**UNDERLIFT TOOLS - FRAME FORKS**

ITEM	PART NO.	DESCRIPTION	QTY
1	3007000004	Adapter, Chain Hook	2
2	7007000056	Adapter, Frame Fork - RH	1
3	7007000055	Adapter, Frame Fork - LH	1
4	3178000226	Spring Lift Bracket	2
5	7454000006	Fork, 3.00" Short	2
6	7454000005	Fork, 3.00" Medium	2
7	7454000003	Fork, 4.50" Medium	2
8	7454000004	Fork, 4.50" Long	2
9	3551000036	T-Handle	2
10	7691000022	Pin	2
11	7691000020	Hairpin	2
12	7691000021	Hitch Pin	2
13	7262000026	Chain, Tie-Down	2

# UNDERLIFT TOOLS - FRAME FORKS

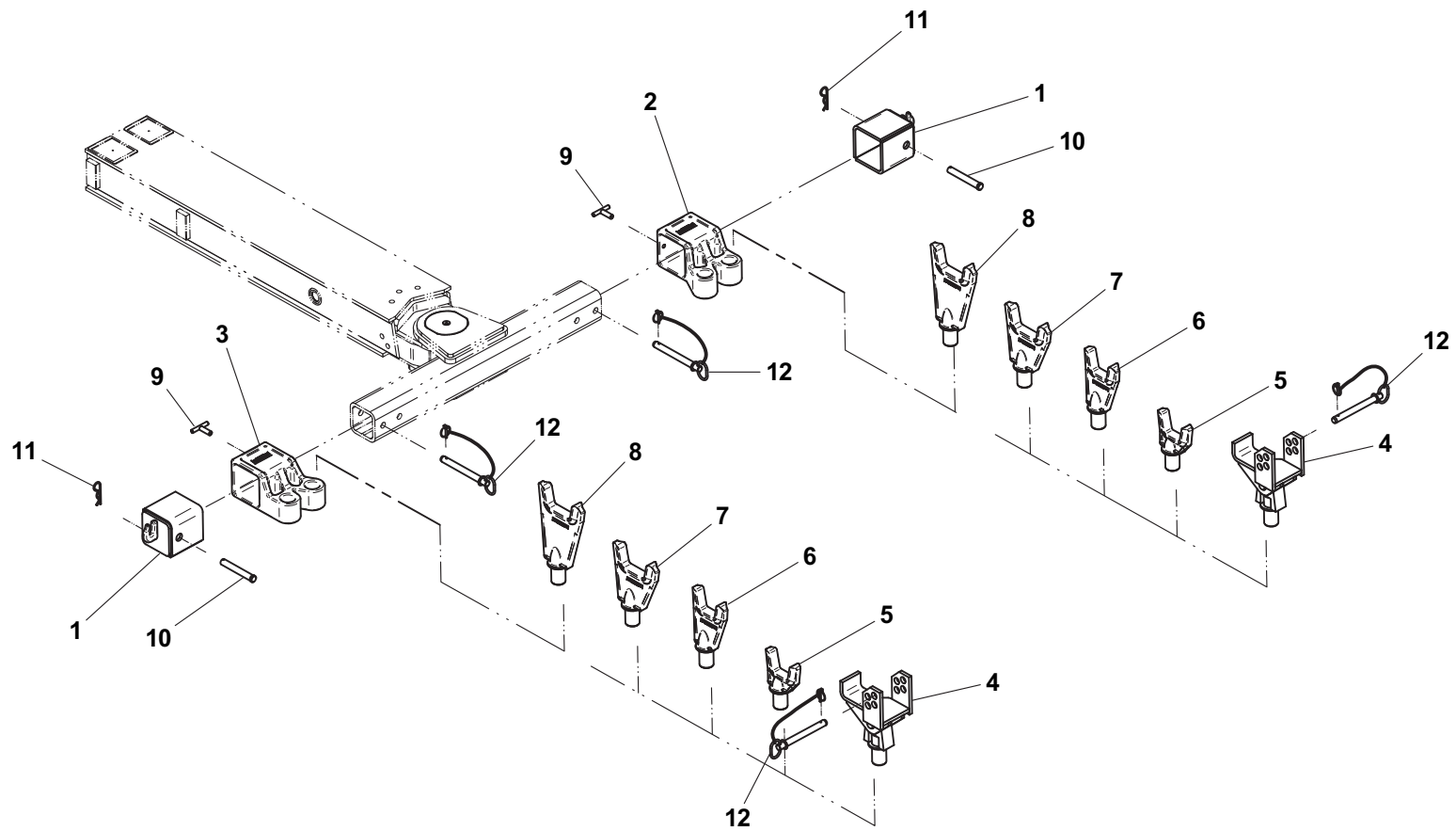

Item #13, not shown

**UNDERLIFT TOOLS - 14,000 LB TIRE LIFT**

ITEM	PART NO.	DESCRIPTION	QTY
1	3484000048*	Tire Lift Grid - RH	1
2	3484000049*	Tire Lift Grid - LH	1
3	3020000120*	Tire Lift Arm Weldment - RH	1
4	3020000119*	Tire Lift Arm Weldment - LH	1
5	3912000038*	Tire Lift Tube Weldment	2
6	7691000026*	Hitch Pin	2
7	4691000274*	Pin	2
8	7691000020*	Hairpin	2
9	7691000021	Hitch Pin	2
10	4561000012*	Hook, Pull	1
11	7894000037*	Strap, 2" Wide (Standard - Yellow)	2
	7894000041*	Strap, 2" Wide (Optional - Orange)	
12	7894000028*	Ratchet, 2" Wide Strap	4
13	3561000008*	Hook, 2" Wide Strap	4
14	7330000550*	Decal	2
15	7759000004*	Rivet	8
16	7330000278*	Decal	2

\* Also available as - 2503550088

# UNDERLIFT TOOLS - 14,000 LB TIRE LIFT

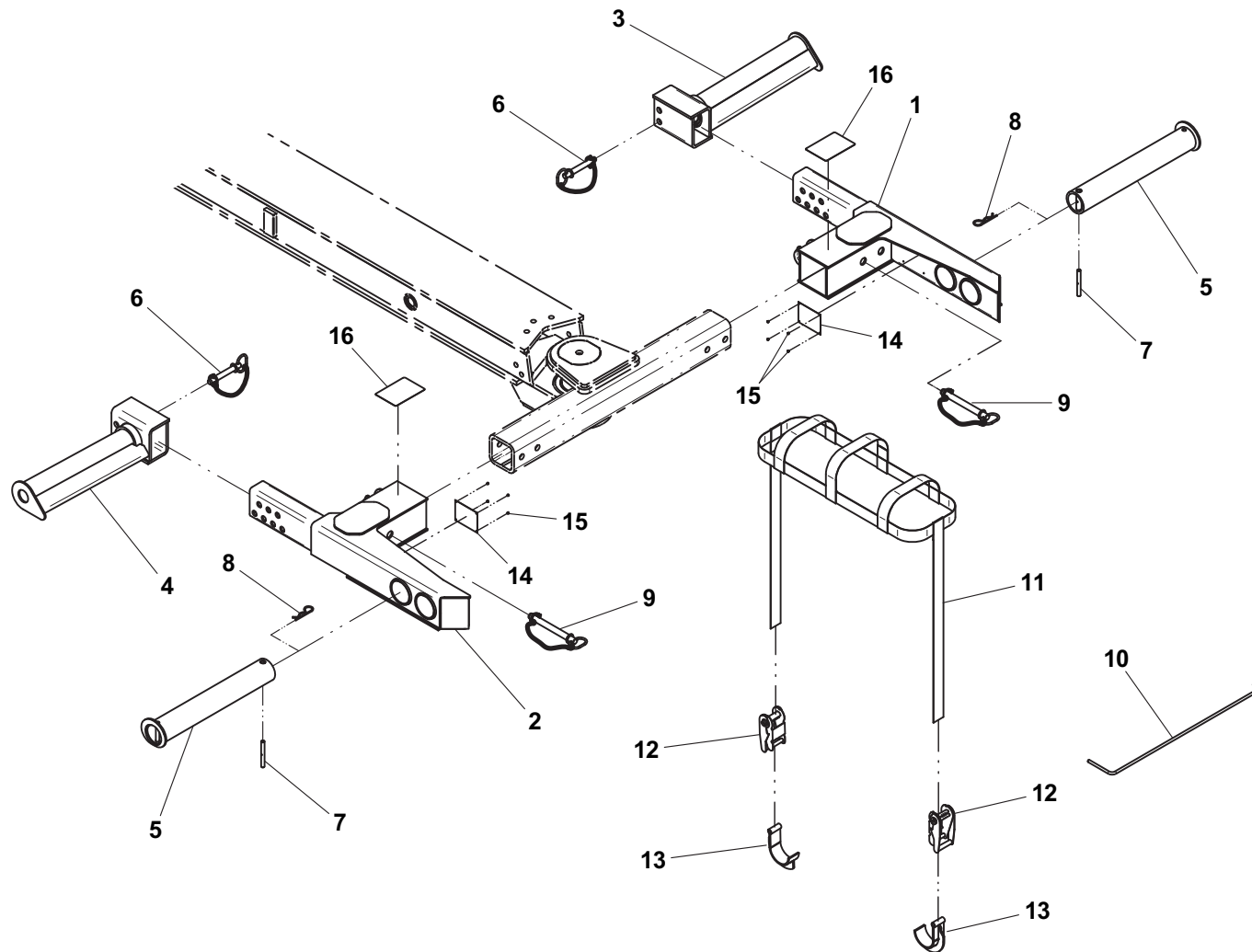

**UNDERLIFT TOOLS - 25,000 LB TIRE LIFT**

ITEM	PART NO.	DESCRIPTION	QTY
1	3484000072^	Tire Lift Grid - LH	1
2	3484000073^	Tire Lift Grid - RH	1
3	3020000119^	Tire Lift Arm Weldment - LH	1
4	3020000120^	Tire Lift Arm Weldment - RH	1
5	3912000038^	Tire Lift Tube Weldment - 23" Long	2
6	3912000033^	Tire Lift Tube Weldment - 27.5" Long	2
7	4691000274^	Pin	2
8	7691000020^	Hairpin	2
9	7330000278^	Decal	2
10	7330000550^	Decal	2
11	7759000004^	Rivet	8
12	4561000012^	Hook, Pull	1
13	3561000015*	Hook, 3" Wide Strap	4
14	7894000060*	Ratchet, 3" Wide Strap	4
15	7894000057*	Strap, 3" Wide	2
16	3561000008^	Hook, 2" Wide Strap	4
17	7894000028^	Ratchet, 2" Wide Strap	4
18	7894000037^	Strap, 2" Wide	2
19	7691000021	Hitch Pin	2
20	7691000026^	Hitch Pin	2

^ Also available as - 2502880300

\* Available in Strap Kit - 7577000368

# UNDERLIFT TOOLS - 25,000 LB TIRE LIFT

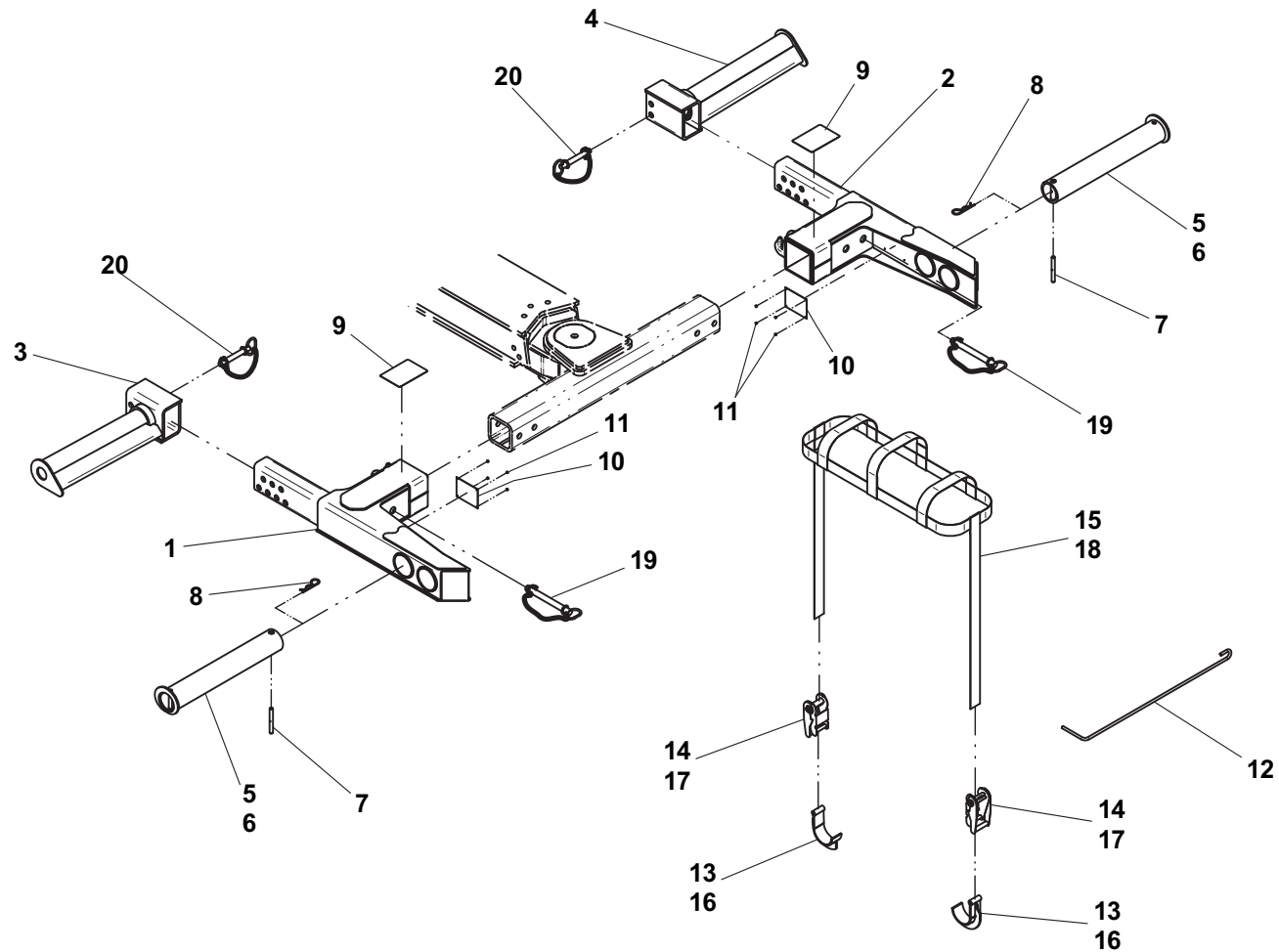

**UNDERLIFT TOOLS - FIFTH WHEEL ATTACHMENT**

ITEM	PART NO.	DESCRIPTION	QTY
1	3178000240*	Bracket Weldment	1
2	3178000499*	Bracket, Fifth Wheel Weldment	1
3	3706000080*	Plate Weldment	1
4	3691000144*	Pin	1
5	3691000145*	Pin	1
6	7118267250*	Capscrew, 1.00"-8NC x 9.00"	2
7	7120000036*	Capscrew, 0.75"-10NC x 3.25"	2
8	7691000025*	Pin	2

\* Also available as - 2503880033



## UNDERLIFT TOOLS - FIFTH WHEEL ATTACHMENT

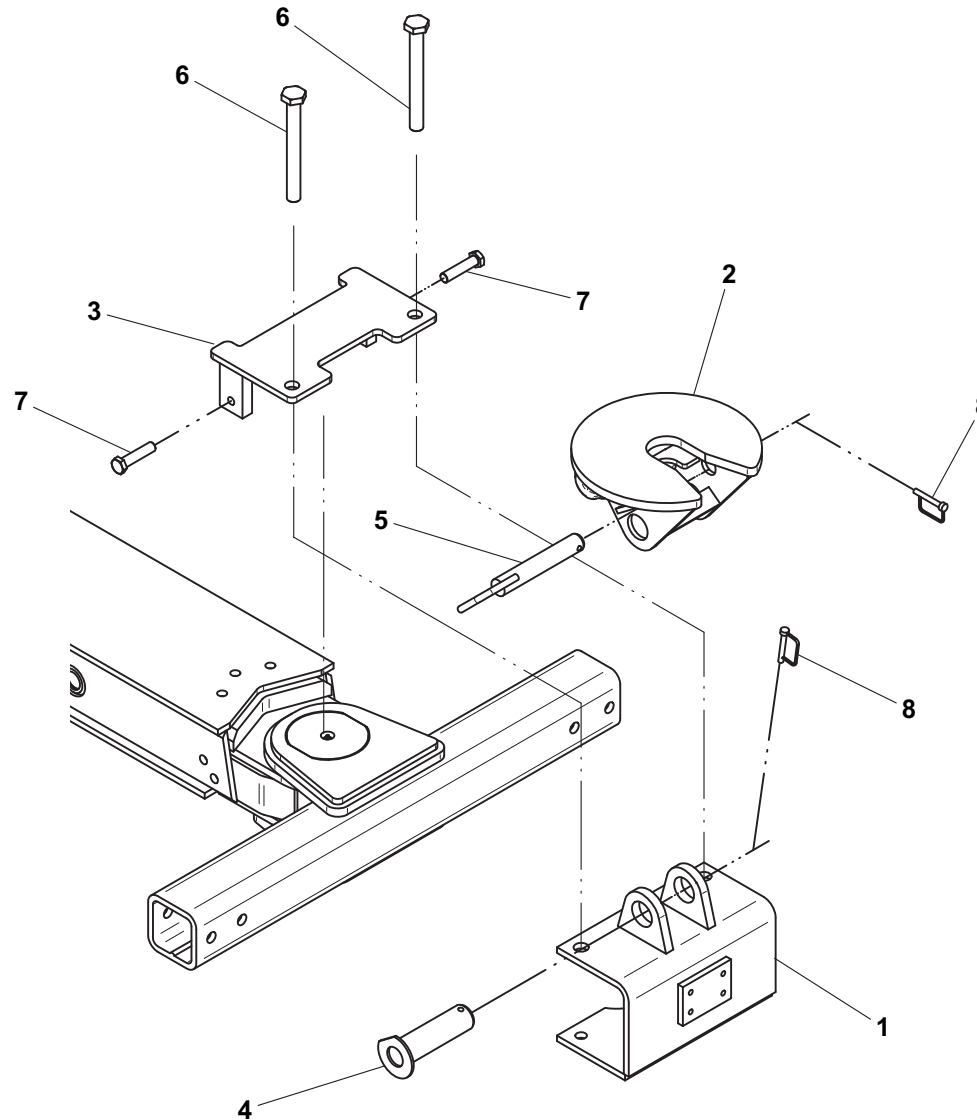

**UNDERLIFT TOOLS - PINTLE HOOK**

ITEM	PART NO.	DESCRIPTION	QTY
1	7561000020	Hitch, Pintle Hook with 2" Dia. Ball	1
2	7118181250	Capscrew, 0.50"-13NC x 1.50"	4
3	7950180000	Lockwasher, 0.50" ID	4
4	7056000003	Ball, 1.88" Dia	1
	7056000004	Ball, 2.00" Dia	
	7056000005	Ball, 2.31" Dia	
	7056000006	Ball, 50mm Dia	

## UNDERLIFT TOOLS - PINTLE HOOK

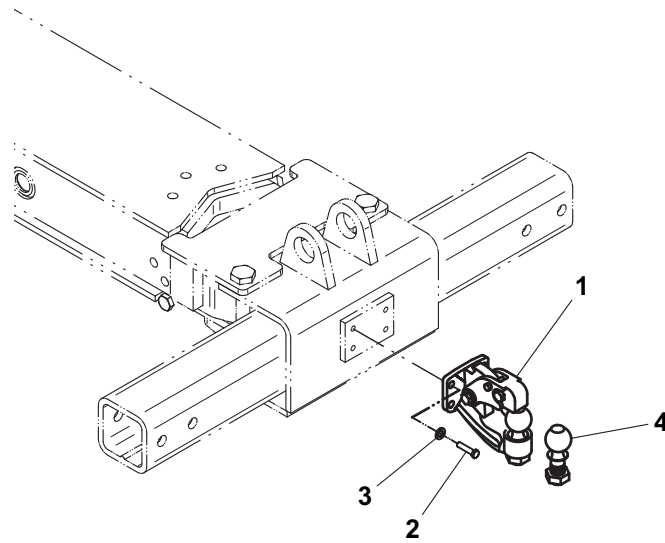

**REAR TAIL PLATE INSTALLATION**

ITEM	PART NO.	DESCRIPTION	QTY
1	4706006008	Plate - LH	1
2	4706006009	Plate - RH	1
3	7759000018	Rivet	8

## REAR TAIL PLATE INSTALLATION

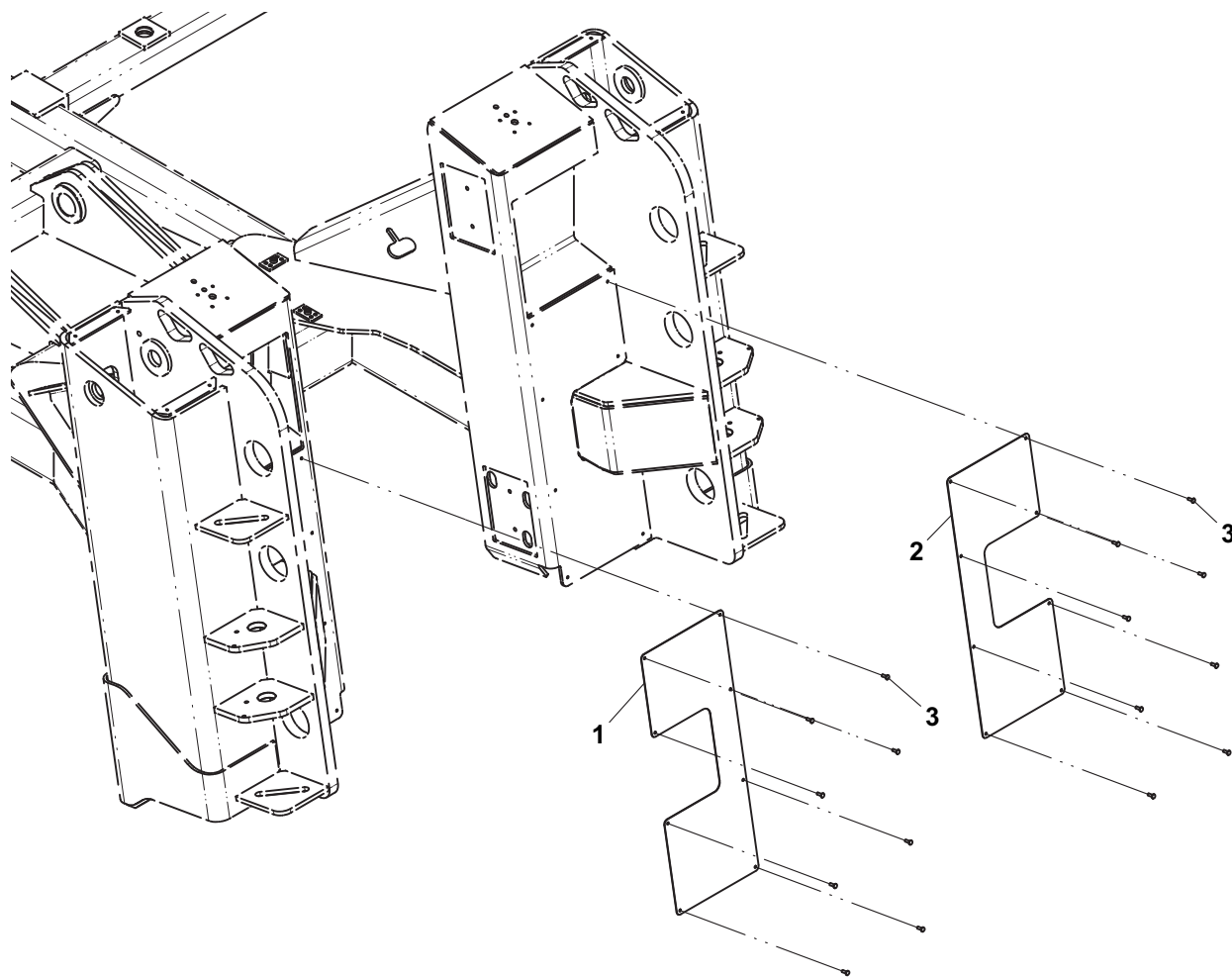

**TAILBOARD D-RING INSTALLATION**

ITEM	PART NO.	DESCRIPTION	QTY
1	4754000004	D-Ring	2
2	3691000176	Pin	2
3	7950160000	Lockwasher, 0.38" ID	2
4	7115160650	Capscrew, 0.38"-16NC x 0.75"	2
5	7440030000	Grease Fitting	2
6	4949000055	Washer	2
7	7691000047	Lynch Pin	2

# TAILBOARD D-RING INSTALLATION

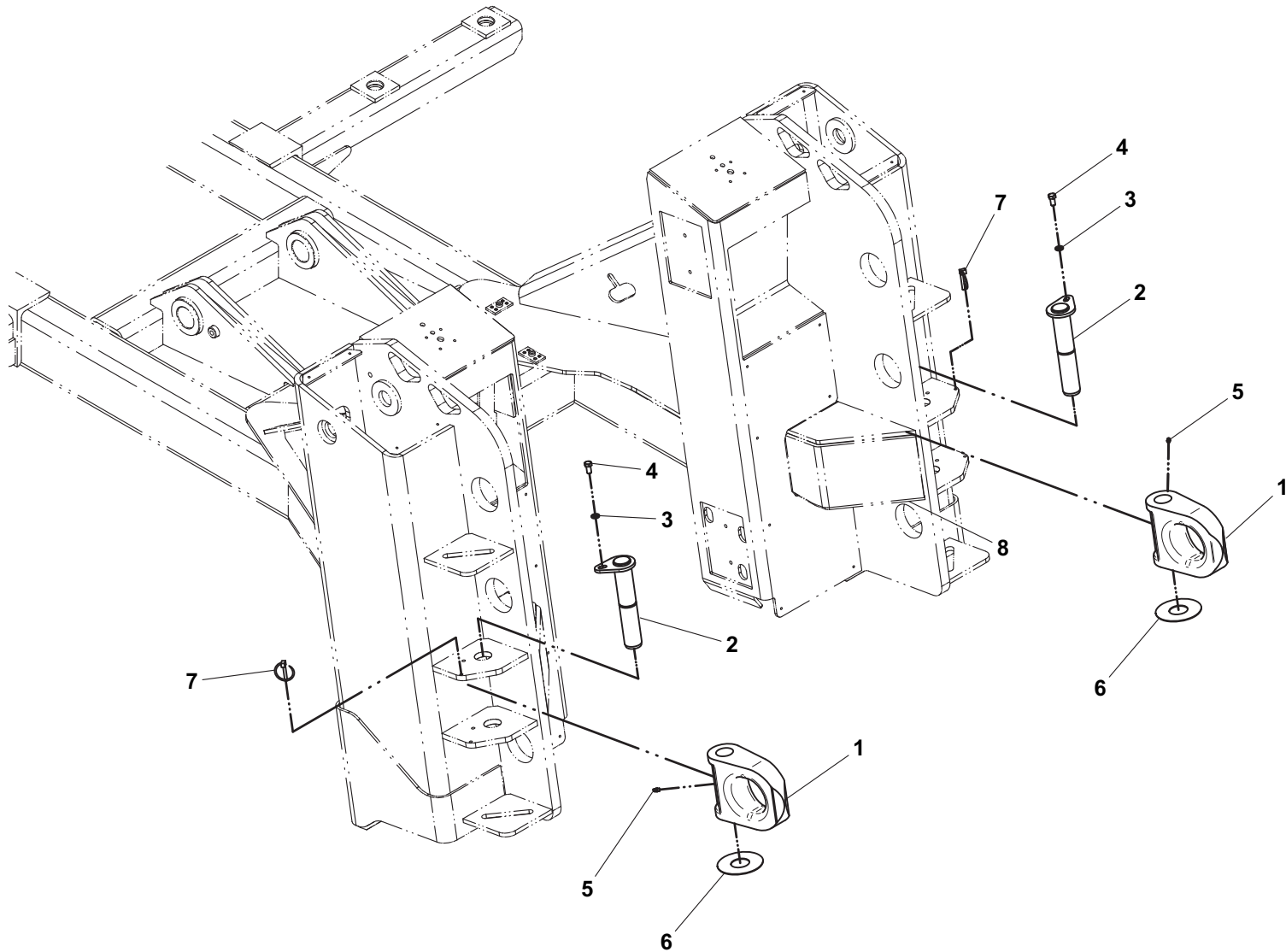

**CONTROLS - CONTROL VALVE INSTALLATION**

ITEM	PART NO.	DESCRIPTION	QTY	ITEM	PART NO.	DESCRIPTION	QTY
1	3935000182	Control Valve Assy - 6 Function Remote	1	34	7701000067	Plug	4
	3935000183	Control Valve Assy - 12 Function Remote		35	7701000058	Plug	4
2	7115162850	Capscrew, 0.38"-16NC x 3.50"	4				
3	7950160161	Flatwasher, 0.38" ID	32				
4	7660162601	Locknut, 0.38"-16NC	13				
5	4706005589	Plate	1				
6	7115161450	Capscrew, 0.38"-16NC x 1.75"	3				
7	7115161050	Capscrew, 0.38"-16NC x 1.25"	6				
8	7660160000	Nut, 0.38"-16NC	3				
9	7115140850	Capscrew, 0.25"-20NC x 1.00"	14				
10	7590140161	Flatwasher, 0.25" ID	25				
11	7661000006	Well Nut, 0.25"-20 NC	8				
12	7796000012	Seal	8ft				
13	7330000257	Decal	1				
14	7660142601	Locknut, 0.25"-20NF	6				
15	4706005591	Plate	1				
16	4706002643	Plate	1				
17	4679000143	Pad, Rubber	1				
18	4679000144	Pad, Rubber	1				
19	7330000199	Decal	1				
20	7330000262	Decal	1				
21	7330000200	Decal	1				
22	7330000256	Decal	1				
23	7330000301	Decal	1				
24	7330000303	Decal	1				
25	7330000253	Decal	1				
26	7330000299	Decal	1				
27	7330000300	Decal	1				
28	4706005658	Plate	1				
29	7413000002	Nutsert, 0.25"-20 NC	5				
30	7950140000	Lockwasher, 0.25" ID	5				
31	7114140618	Capscrew, 0.25"-20NC x 0.75"	5				
32	4314000208	Coverplate	1				
33	4314000209	Coverplate	1				



# CONTROLS - CONTROL VALVE INSTALLATION

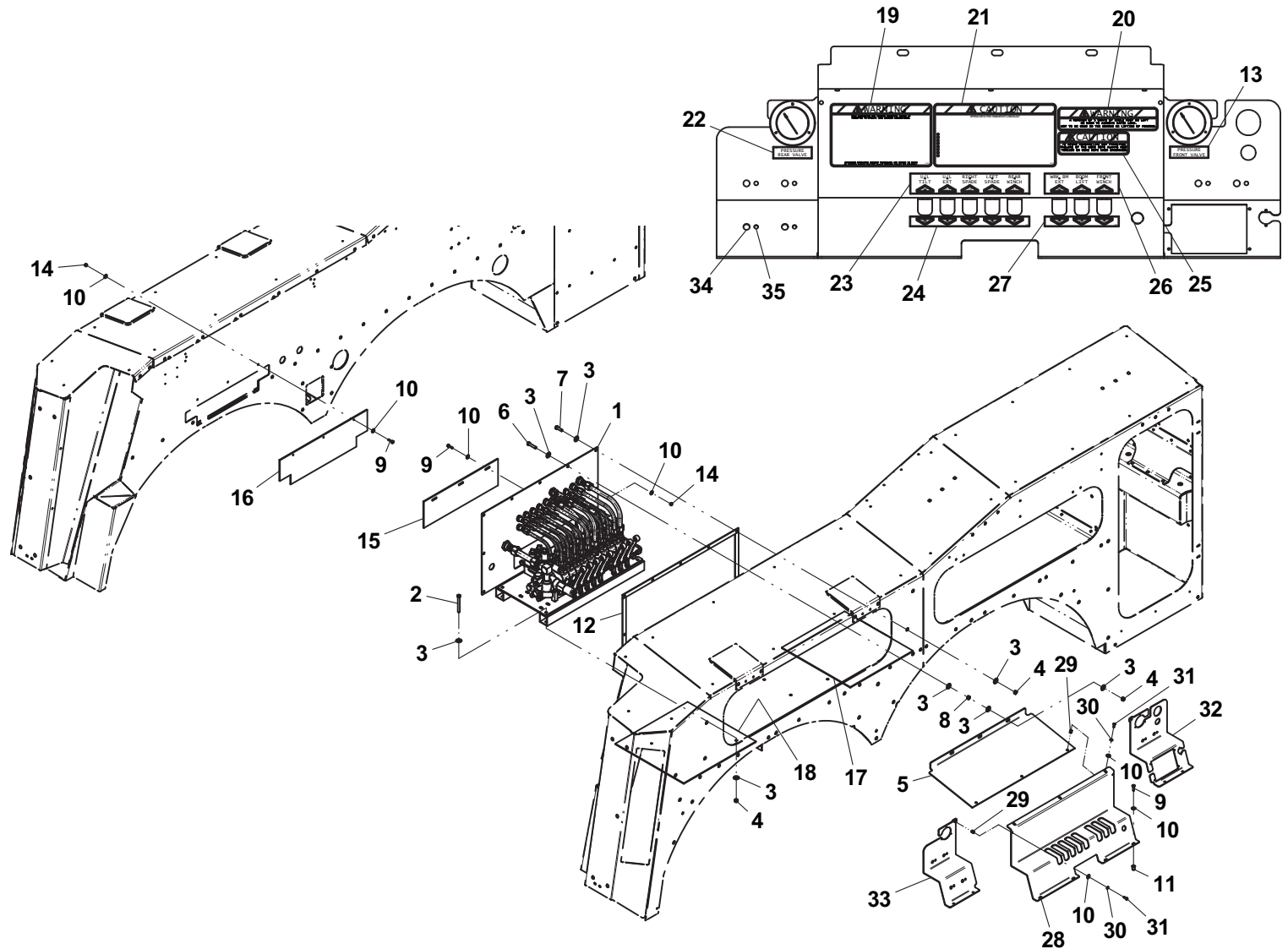

**CONTROLS - PUSH-PULL CABLES INSTALLATION**

ITEM	PART NO.	DESCRIPTION	QTY	ITEM	PART NO.	DESCRIPTION	QTY
1	4706005659	Plate, RH Cable Bracket	1	34	7330000253	Decal	1
2	4314000210	Coverplate	1	35	4309000007	Coupling, Cable - 6 Function Remote	5
3	7950160161	Flatwasher, 0.38" ID	8		4309000007	Coupling, Cable - 12 Function Remote	2
4	7660162601	Locknut, 0.38"-16NC	4	36	7330000704	Decal	1
5	4706002496	Plate	1	37	7701000067	Plug	4
6	7115140650	Capscrew, 0.25"-20NC x 0.75"	3				
7	7115161050	Capscrew, 0.38"-16NC x 1.25"	4				
8	4411000113	Extrusion, Brush Holder	1				
9	7115140850	Capscrew, 0.25"-20NC x 1.00"	3				
10	7590140161	Flatwasher, 0.25" ID	22				
11	7661000006	Well Nut, 0.25"-20 NC	10				
12	4638000003	Brush	1				
13	3686000016	Panel Weldment	1				
14	7660142601	Locknut, 0.25"-20NF	6				
15	3178000260	Bracket Weldment	1				
16	7790141056	Screw, Self Tapping - 0.25"-10NC x 0.63"	13				
17	7806000005	Shaft	1				
18	7754000009	Retaining Ring	2				
19	7082000005	Bearing	2				
20	7551000034	Handle	8				
21	7701000058	Plug	4				
22	7248000053	Push-Pull Cable	8				
23	7990000003	Yoke	8				
24	4309000001	Coupling - 6 Functions Remote	3				
	4309000001	Coupling - 12 Function Remote	6				
25	7690141200	Clevis Pin	16				
26	7690000810	Cotter Pin	16				
27	7660140230	Nut, 0.25"-28NF	16				
28	7111140813	Screw, 0.25-20N x 1.00"	10				
29	4831000123	Spacer	1				
30	7330000199	Decal	1				
31	7330000262	Decal	1				
32	7330000200	Decal	1				
33	7330000705	Decal	1				

# CONTROLS - PUSH-PULL CABLES INSTALLATION

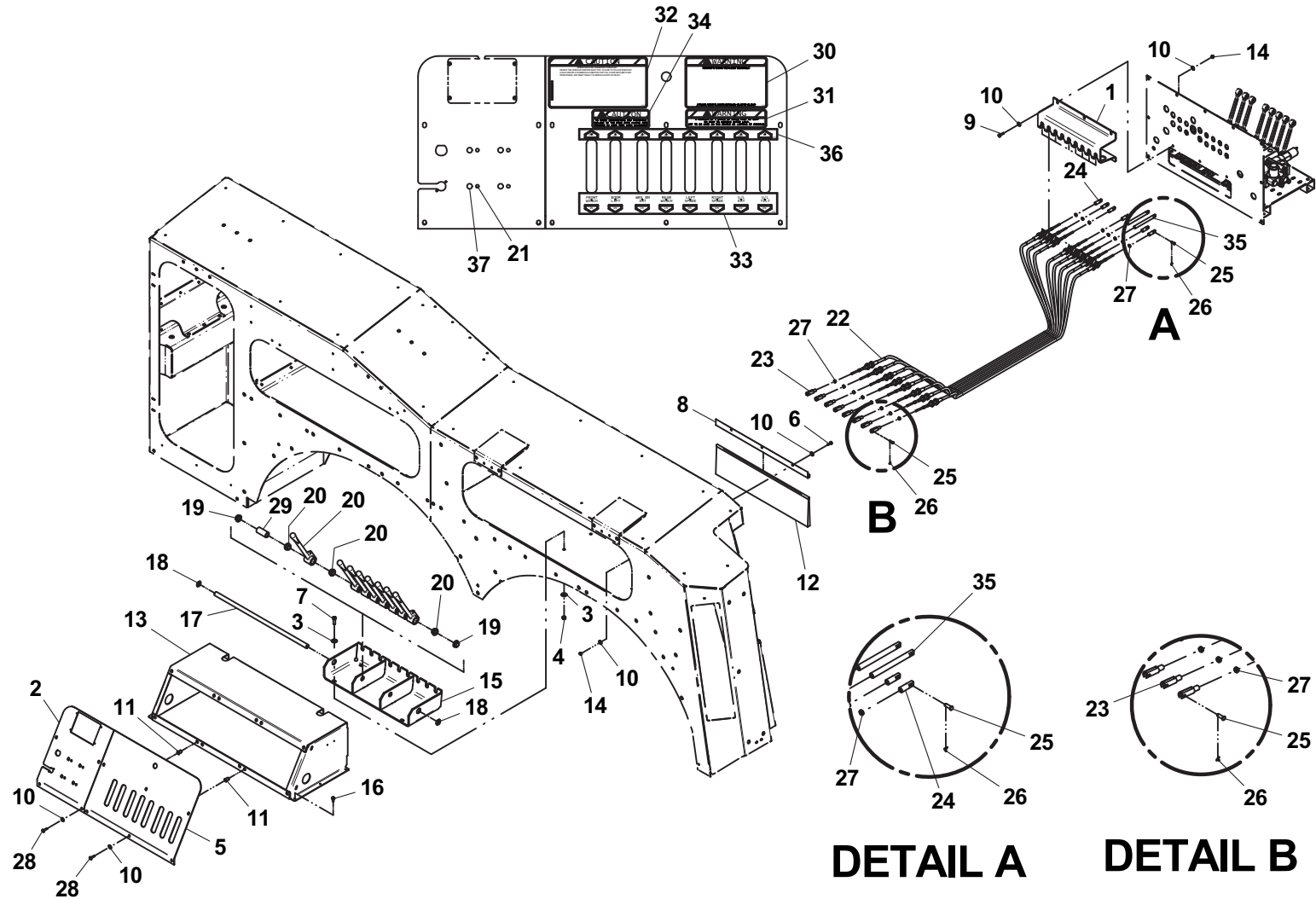

Push-Pull Cable Installation for 12 Function Remote Controller shown

**CONTROLS - CONTROL VALVE ASSEMBLY**

ITEM	PART NO.	DESCRIPTION	QTY
1	3177000060	Valve Mount Weldment	1
2	4706005657	Plate	1
3	3935000186	Valve Assembly - 6 Function Remote	1
	3935000187	Valve Assembly - 12 Function Remote	
4	7912000301*	Tube Assembly	1
5	7912000302*	Tube Assembly	1
6	7912000303*	Tube Assembly	1
7	7912000304*	Tube Assembly	1
8	7912000305*	Tube Assembly	1
9	7912000306*	Tube Assembly	2
10	7912000307*	Tube Assembly	2
11	7912000308*	Tube Assembly	6
12	7115152450	Capscrew, 0.31"-18NC x 3.00"	3
13	7660152601	Locknut, 0.31"-18NC	3
14	7950140161	Flatwasher, 0.31" ID	3
15	7445060625	Fitting, Union Bulkhead	1
16	7443000012	Tee	1
17	7445121225	Fitting, Union Bulkhead	2
18	7445161625	Fitting, Union Bulkhead	3
19	7445080825	Fitting, Union Bulkhead	12
20	7445101025	Fitting, Union Bulkhead	4
21	7445081043	Adapter	12
22	7445101043	Adapter	4
23	7445121243	Adapter	2
24	7443000211	Elbow	2
25	7445151243	Adapter	1
26	7912000309*	Tube Assembly	6
27	7912000310*	Tube Assembly	1
28	7445060645	Elbow	1

\* Available in Hydraulic Tubing Kit - 7577000668

# CONTROLS - CONTROL VALVE ASSEMBLY

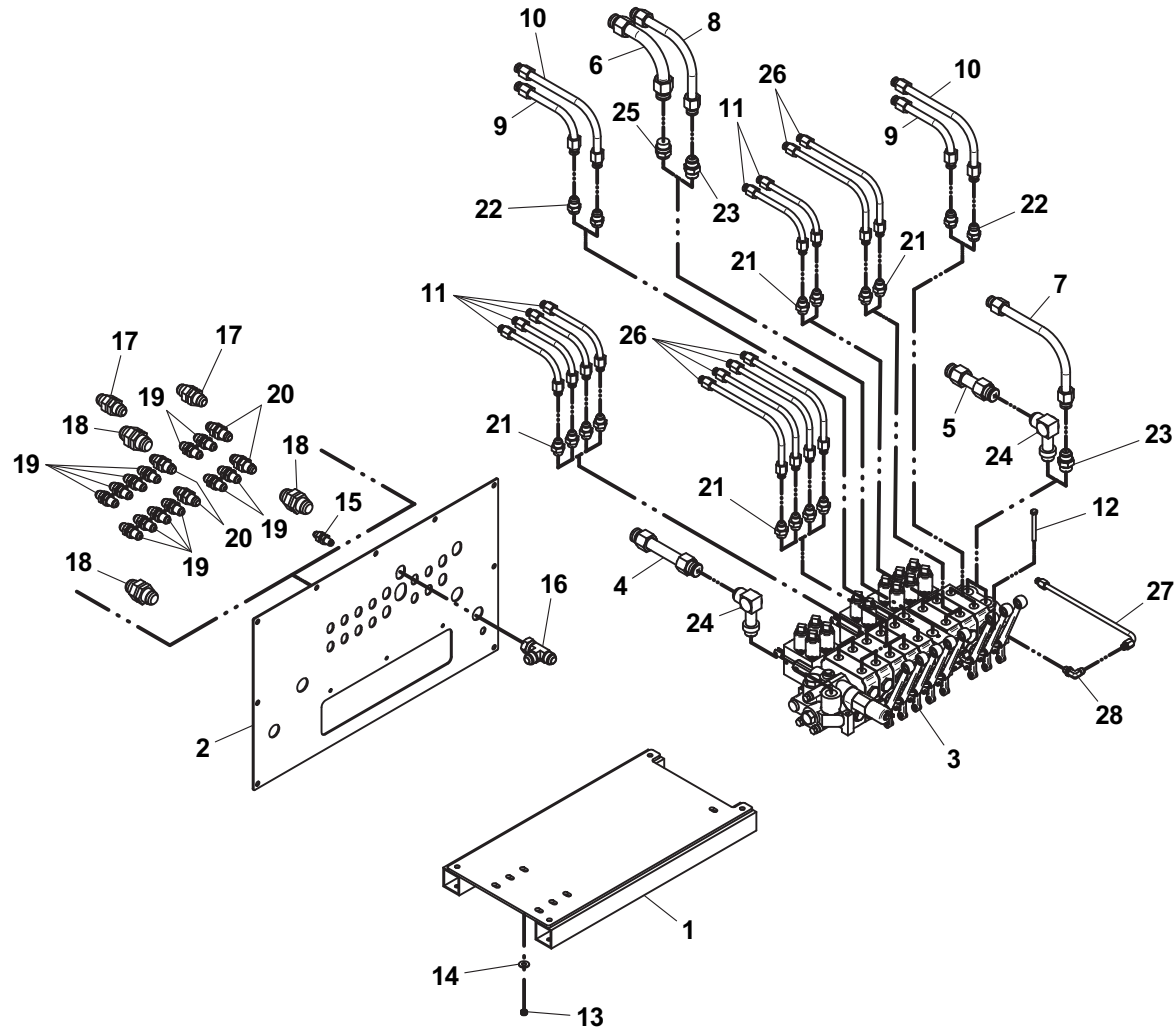

**CONTROLS - 6 FUNCTION NON-PROPORTIONAL MIRATRON**

ITEM	PART NO.	DESCRIPTION	QTY
1	7295000146	Antenna	1
2	7552000383	Harness	1
3	7552000148	Harness	1
4	7493000014	Grommet	2
5	7493000011	Grommet	1
6	7740000001	Relay, 40 Amp	1
7	7457000011	Relay, 40 Amp	1
8	7346000068	Dust Cap	1
9	7114100518	Capscrew, #10-24NC x 0.63"	4
10	7660102604	Locknut, #10-24NC	4
11	3314000010	Coverplate	2
12	7950140161	Flatwasher, 0.25" ID	8
13	7660142601	Locknut, 0.25"-20NC	4
14	7111140613	Screw, 0.25"-20NC x 0.75"	4
15	5526000553	Tie Strap	5
16	7701000007	Plug	1
17	7701000032	Plug	1
18	7346000039	Tubing, Heat Shrink	12in
19	7661000023	Locknut, #10-32NF	2
20	7790100856	Screw, Self Tapping - #10 Dia x 0.50"	3
21	7493000020	Grommet	1

# CONTROLS - 6 FUNCTION NON-PROPORTIONAL MIRATRON

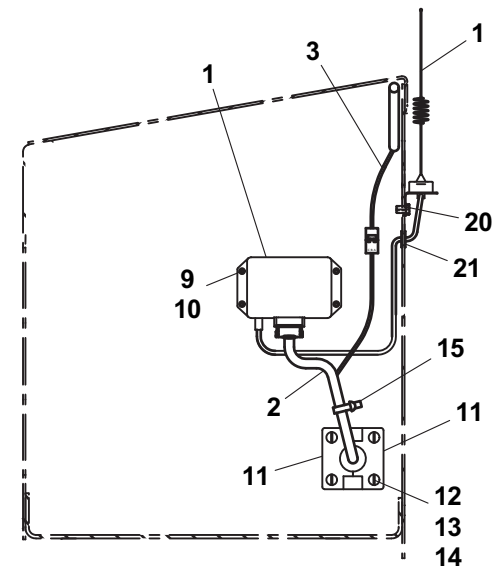
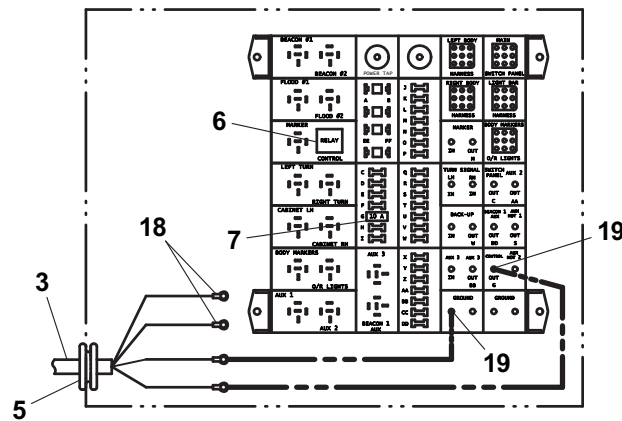
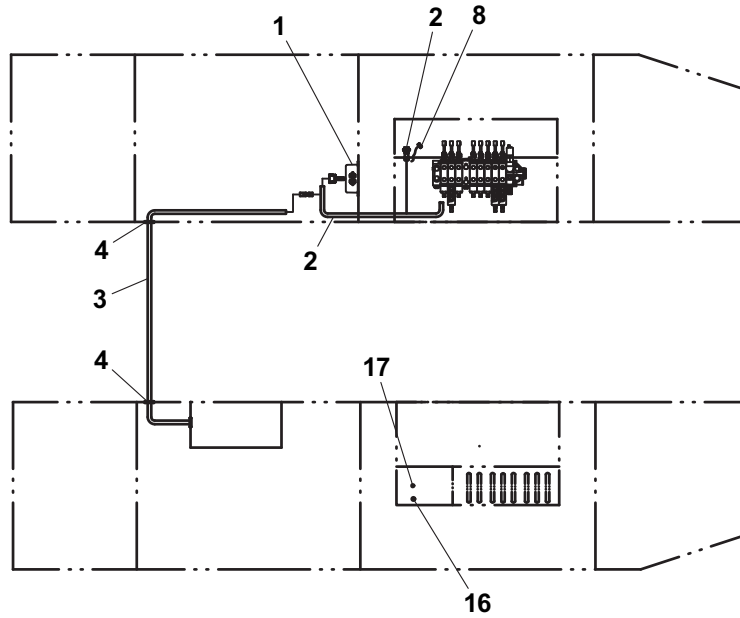

**CONTROLS - 12 FUNCTION NON-PROPORTIONAL MIRATRON**

ITEM	PART NO.	DESCRIPTION	QTY
1	7295000124	Remote Controller	1
2	7552000371	Harness	1
3	7552000148	Harness	1
4	7493000014	Grommet	2
5	7493000011	Grommet	1
6	7346000029	In-Line Fuse Holder	1
7	7457000008	Fuse - 10 Amp	1
8	7345001714	Electrical Terminal	2
9	7346000039	Tubing, Heat Shrink	12in
10	7661000023	Locknut, #10-32NF	2
11	7740000001	Relay, 40 Amp	1
12	7457000006	Fuse - 15 Amp	1
13	7894000042	Tie Strap	2
14	7115141250	Capscrew, 0.25"-20NC x 1.50"	2
15	7950140161	Flatwasher, 0.25" ID	12
16	7660142600	Locknut, 0.25"-20NC	6
17	3314000010	Coverplate	2
18	7115140650	Capscrew, 0.25"-20NC x 0.75"	4
19	7701000007	Plug	1
20	5526000553	Tie Strap	5



# CONTROLS - 12 FUNCTION NON-PROPORTIONAL MIRATRON

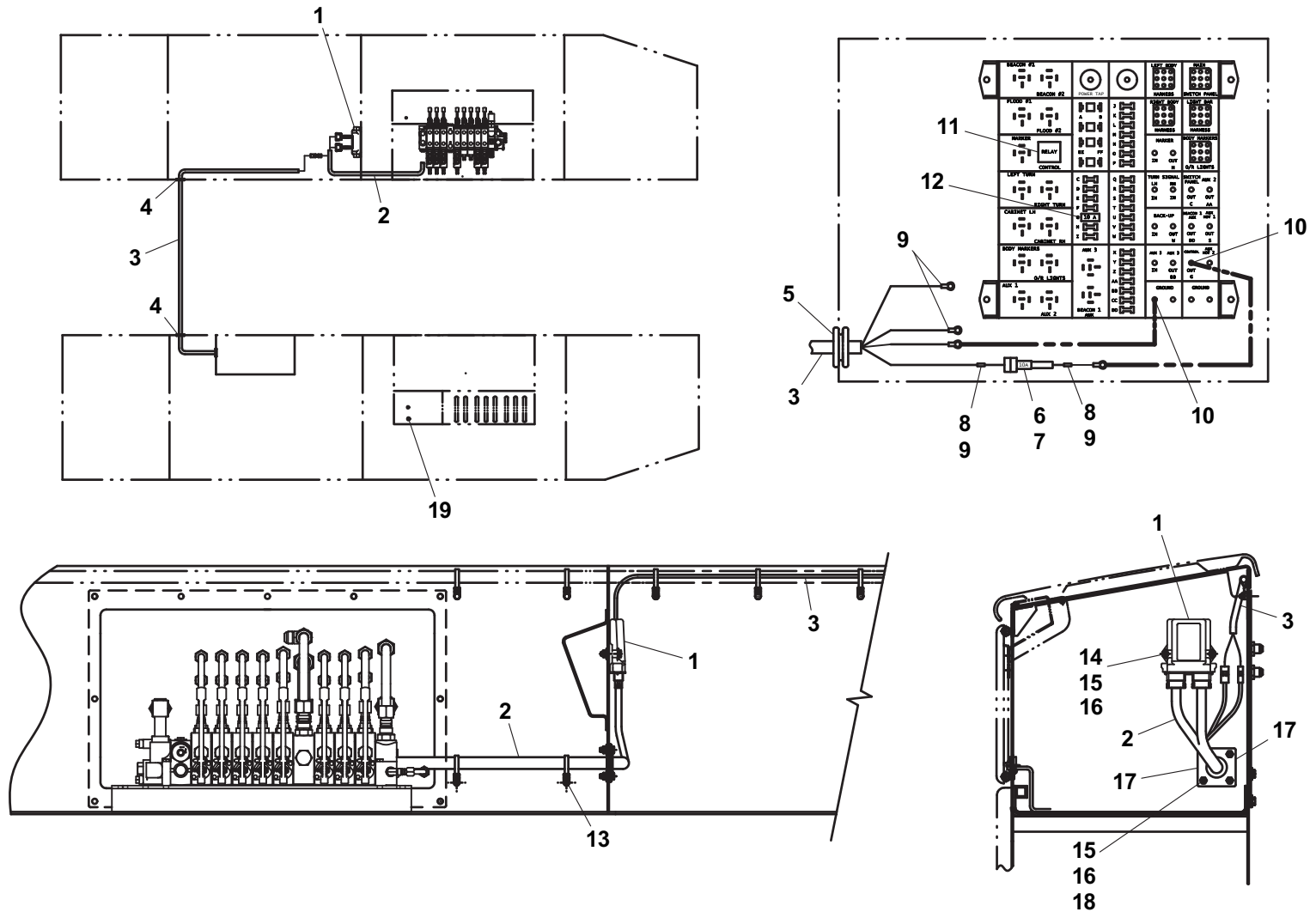

Item #20, not shown

**CONTROLS - 12 FUNCTION PROPORTIONAL MIRATRON**

ITEM	PART NO.	DESCRIPTION	QTY
1	7295000148	Remote Controller	1
2	7295000146	Antenna	1
3	7552000433	Harness	1
4	7552000148	Harness	1
5	7493000014	Grommet	2
6	7493000011	Grommet	1
7	7346000039	Tubing, Heat Shrink	12in
8	7740000001	Relay, 40 Amp	1
9	7457000006	Fuse - 15 Amp	1
10	7894000004	Tie Strap	1
11	8632000012	Trim	30in
12	4178000699	Bracket	1
13	7950140161	Flatwasher, 0.25" ID	12
14	7660142601	Locknut, 0.25"-20NC	10
15	7111140813	Screw, 0.25-20N x 1.00"	4
16	7120000047	Screw, #4-40NC x 0.63"	2
17	7660040000	Nut, #4-40NC	2
18	3314000010	Coverplate	2
19	7111140613	Screw, 0.25"-20NC x 0.75"	4
20	7115141250	Capscrew, 0.25"-20NC x 1.50"	2
21	7493000020	Grommet	2
22	5526000553	Tie Strap	5
23	7114100518	Capscrew, #10-24NC x 0.63"	4
24	7660102604	Locknut, #10-24NC	4
25	7790100856	Screw, 0.25"-20NC x 0.75"	6
26	7661000023	Locknut, #10-32NF	2
27	7075000006	Battery	3
28	7075000003	Battery	1

# CONTROLS - 12 FUNCTION PROPORTIONAL MIRATRON

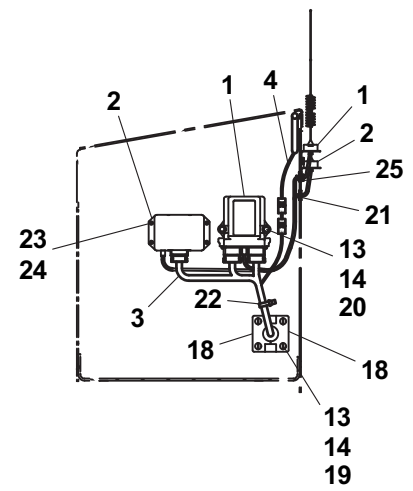
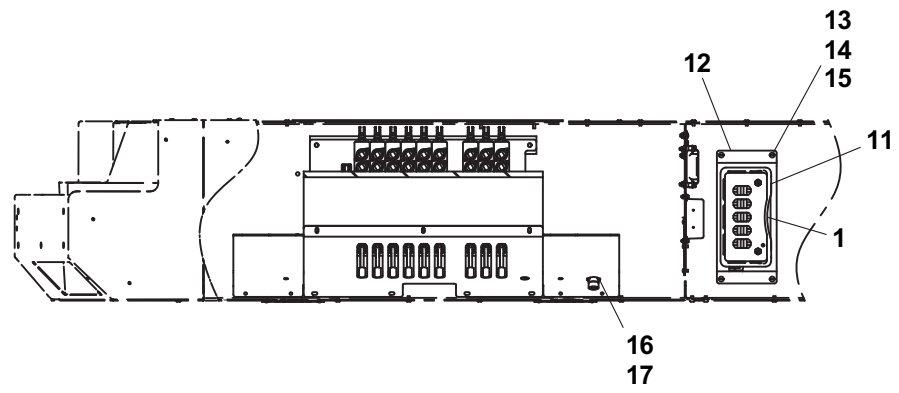
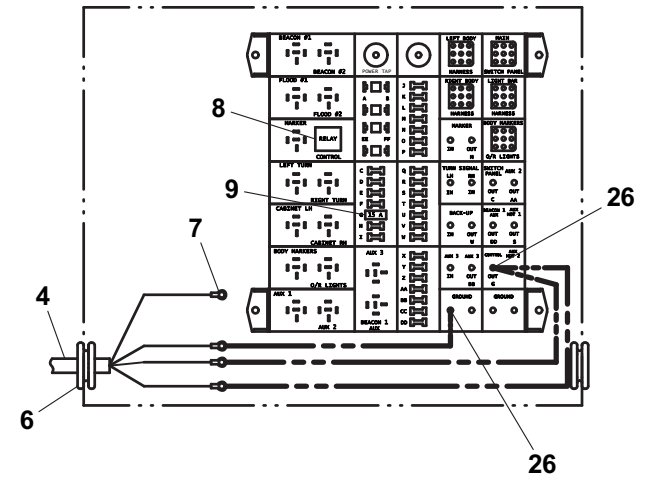
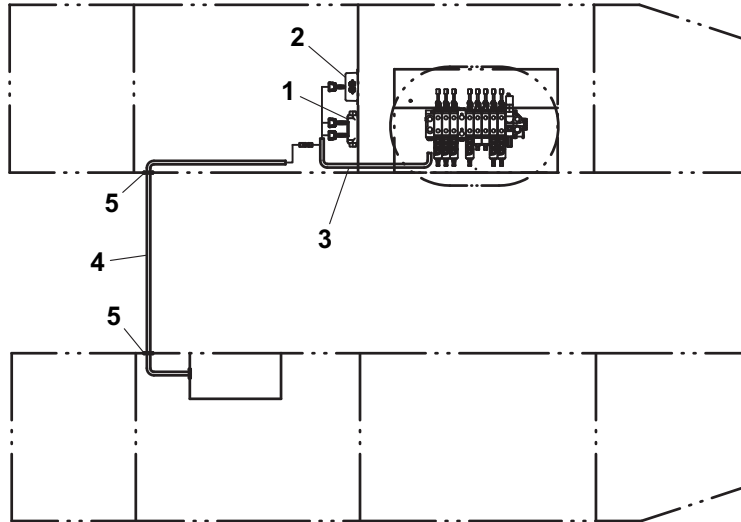

Items #20, #27 and #28, not shown

**CONTROLS - ELECTRICAL EMERGENCY STOP**

ITEM	PART NO.	DESCRIPTION	QTY
1	8977010103	Wire, 16GA. - 2 Conductor	40ft
2	7346000094	Electrical Connector	1
3	7346000035	Electrical Terminal	2
4	7346000037	Seal, Cable	6
5	7346000087	Electrical Connector	2
6	7346000099	Electrical Terminal	4
7	8977500100	Wire, 16GA. Black	3in
8	7870000128	Switch, Emergency Pushbutton	2
9	7870000129	Switch, Emergency Contact Block	2
10	7345001704	Electrical Terminal	3
11	7346000039	Tubing, Heat Shrink	6in
12	7330000755	Decal	2
13	5526000553	Tie Strap	1

# CONTROLS - ELECTRICAL EMERGENCY STOP

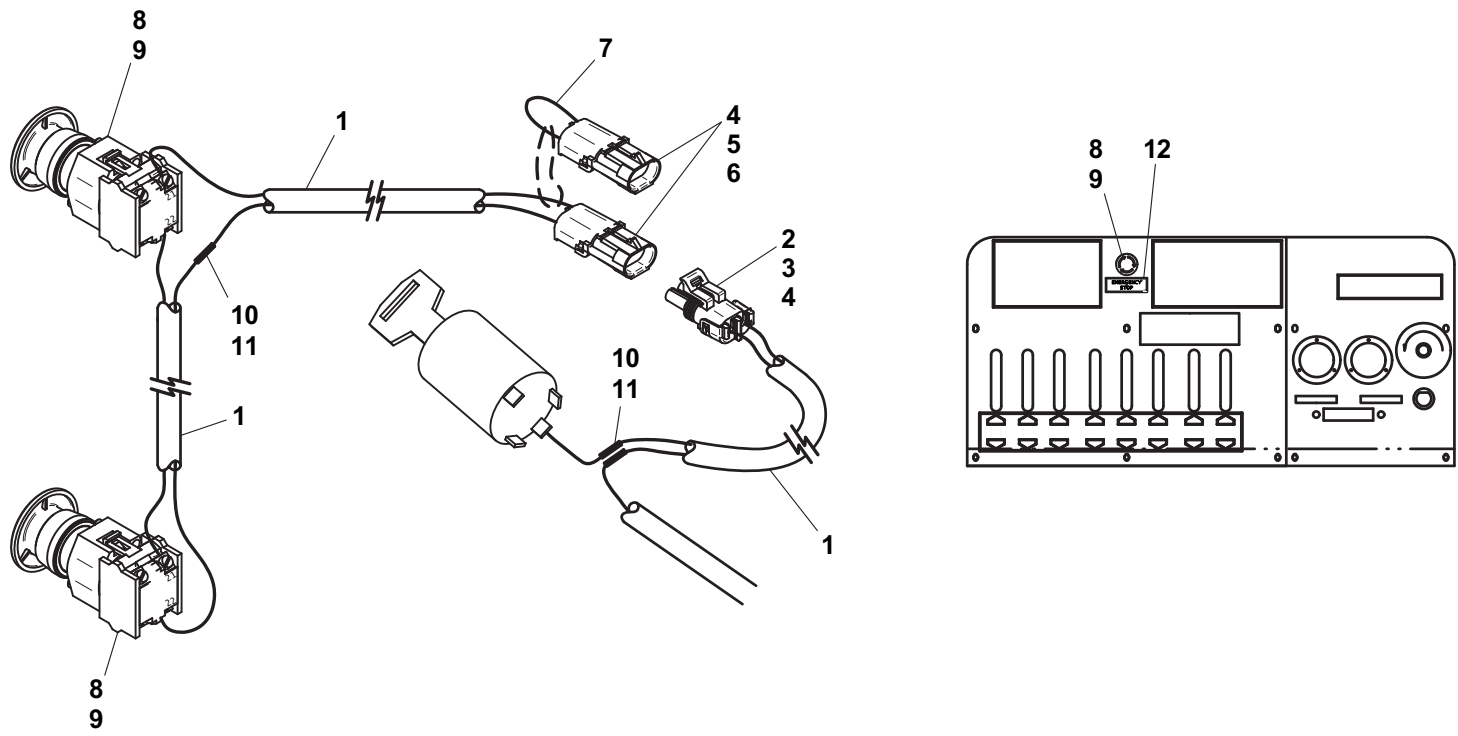

Item #13, not shown

**HYDRAULICS - SUPPLY-PRESSURE-RETURN**

ITEM	PART NO.	DESCRIPTION	QTY
1	7650100137	Pipe Nipple	1
2	7444121050	Reducer	1
3	7635000116	Valve, Ball	1
4	7444121271	Elbow	1
5	7443000130	Fitting	1
6	7274000028	Clamp	1
7	See Note 1	Hose - Supply	1
8	7443000222	Fitting	1
9	7577000213	Split Flange	1
10	7724000044	Pump	1
11	7115181050	Capscrew, 0.50"-13NC x 1.25"	2
12	7950180000	Lockwasher, 0.50" ID	2
13	7445121645	Elbow	2
14	See Note 1	Hose - Pressure	2
15	7430000010	Filter, Tank	1
16	4706003844	Plate	5
17	7274000071	Clamp	5
18	7274000040	Clamp	10
19	7115140850	Capscrew, 0.25"-20NC x 1.00"	10
20	7950140152	Flatwasher, 0.25" ID	10
21	7660142601	Locknut, 0.25"-20NC	10
22	7115181250	Capscrew, 0.50"-13NC x 1.50"	5
23	7660000011	Locknut, 0.50"-13NC	5
24	4178000248	Bracket	1

Note 1: Varies depending on chassis, transmission and PTO type.  
Consult factory for part numbers.

# HYDRAULICS - SUPPLY-PRESSURE-RETURN

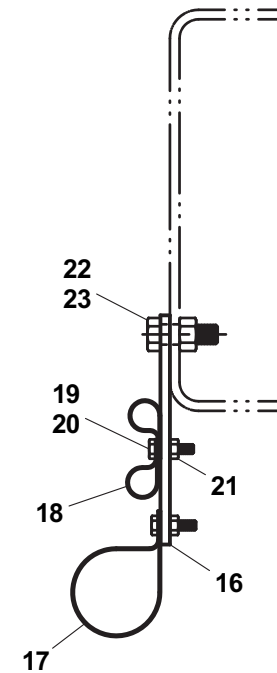
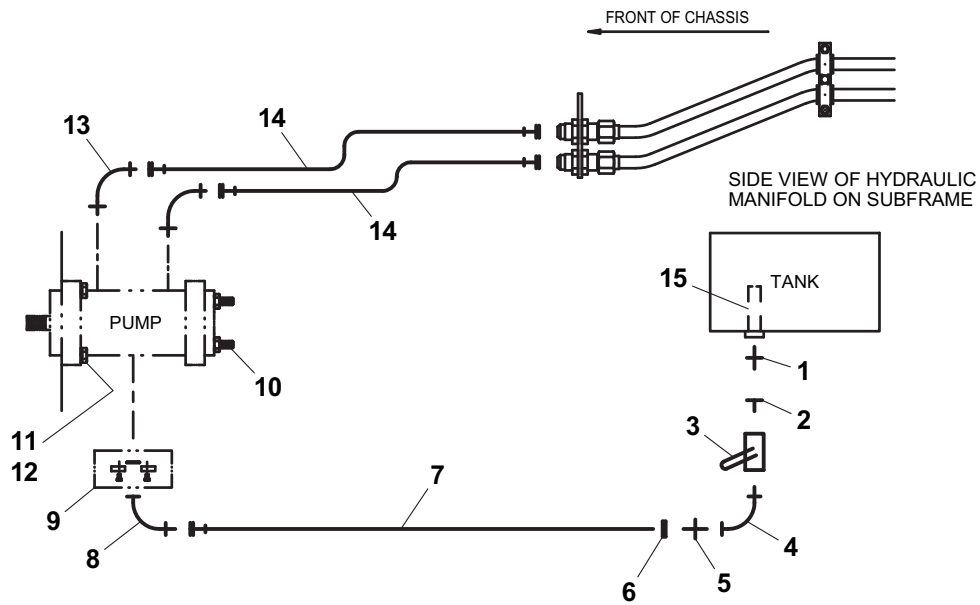

TYP FRAME SUPPORT

Item #24, not shown

**HYDRAULICS - LINES AND FITTINGS**

ITEM	PART NO.	DESCRIPTION	QTY	ITEM	PART NO.	DESCRIPTION	QTY
1	7470000004	Gauge, Pressure	2	35	4570000162*	Hose Assembly	2
2	7790060676	Screw, #6 x 0.38"	6	36	4570000313*	Hose Assembly	1
3	7445040421	Fitting	2	37	4569182025*	Hose Assembly	1
4	7443000207	Reducer	1	38	4567183040*	Hose Assembly	1
5	7445040443	Adapter	1	39	4569183054*	Hose Assembly	1
6	7445060643	Adapter	8	40	4567182029*	Hose Assembly	1
7	7443000109	Adapter - 2 Piece Wrecker Boom	4	41	4567182024*	Hose Assembly	1
	7443000109	Adapter - 3 Piece Wrecker Boom	2	42	4569173038*	Hose Assembly	1
8	7174000063	Clamp	2	43	4569173026*	Hose Assembly	1
9	7445060219	Adapter	1	44	4569143028*	Hose Assembly	1
10	7430000004	Filter Assembly	2	45	4569142025*	Hose Assembly	1
11	7443000150	Adapter	2	46	4567133032*	Hose Assembly	1
12	7470000002	Gauge, Filter	2	47	4567132031*	Hose Assembly	1
13	7443000213	Tee	1	48	4567132043*	Hose Assembly	4
14	7445161672	Elbow	1	49	4569132055*	Hose Assembly	1
15	7445161622	Union	2	50	4569133053*	Hose Assembly	1
16	7445161620	Elbow	2	51	4569130046*	Hose Assembly	6
17	7445080822	Union	2	52	4569132052*	Hose Assembly	1
18	7445080837	Union	2	53	4569133052*	Hose Assembly	1
19	7445080843	Adapter	4	54	4569130044*	Hose Assembly	2
20	7445060645	Elbow	2	55	4570000362*	Hose Assembly	2
21	4619000006	Manifold	1	56	4570000167*	Hose Assembly	2
22	7115161650	Capscrew, 0.38"-16NC x 2.00"	2	57	4567120017*	Hose Assembly	2
23	7950160000	Lockwasher, 0.38" ID	2	58	4570000366*	Hose Assembly	1
24	7445101032	Fitting	4	59	4570000367*	Hose Assembly	1
25	7445100843	Adapter	4	60	4567132048*	Hose Assembly	2
26	7443000479	Adapter - 3 Piece Wrecker Boom	2	61	4569163024*	Hose Assembly	1
27	4819000008	Sleeve	2	62	4569162024*	Hose Assembly	1
28	7894000004	Tie Strap	6	63	4569163034*	Hose Assembly	1
29	4567113028*	Hose Assembly	1	64	4569162034*	Hose Assembly	1
30	4567112024*	Hose Assembly	1	65	4569160046*	Hose Assembly	4
31	4569133027*	Hose Assembly	1	66	4567160048*	Hose Assembly	4
32	4569132030*	Hose Assembly	2	67	4570000368*	Hose Assembly	2
33	4569133032*	Hose Assembly	1	68	4570000360+	Hose Assembly - UL530 Underlift	2
34	4570000163*	Hose Assembly	2		4570000252^	Hose Assembly - UL565 Underlift	2



## HYDRAULICS - LINES AND FITTINGS

ITEM	PART NO.	DESCRIPTION	QTY
69	4567152025<	Hose Assembly - Motor Shift Winch	1
	4567152033>	Hose Assembly - Gear Shift Winch	1
70	4567152024<	Hose Assembly - Motor Shift Winch	1
	4567152032>	Hose Assembly - Gear Shift Winch	1
71	4567152056<	Hose Assembly - Motor Shift Winch	1
	4567152066>	Hose Assembly - Gear Shift Winch	1
72	4567152054<	Hose Assembly - Motor Shift Winch	1
	4567152060>	Hose Assembly - Gear Shift Winch	1

\* Available in Hydraulic Hose Kit - 7577000570

+Available in Hydraulic Hose Kit - 7577000571

^ Available in Hydraulic Hose Kit - 7577000572

<Available in Hydraulic Hose Kit - 7577000570

>Available in Hydraulic Hose Kit - 7577000573

**HYDRAULICS - LINES AND FITTINGS**

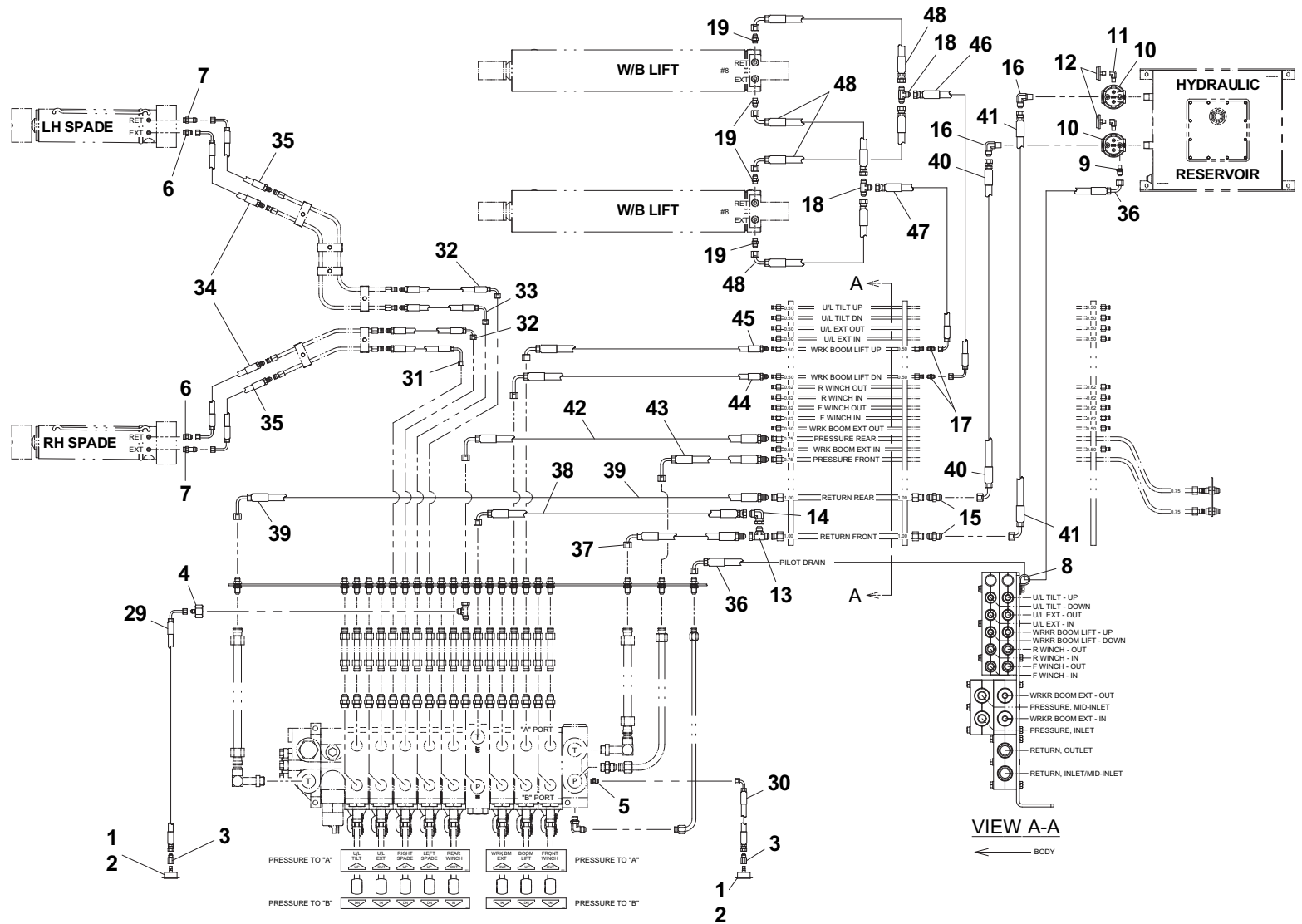

# HYDRAULICS - LINES AND FITTINGS

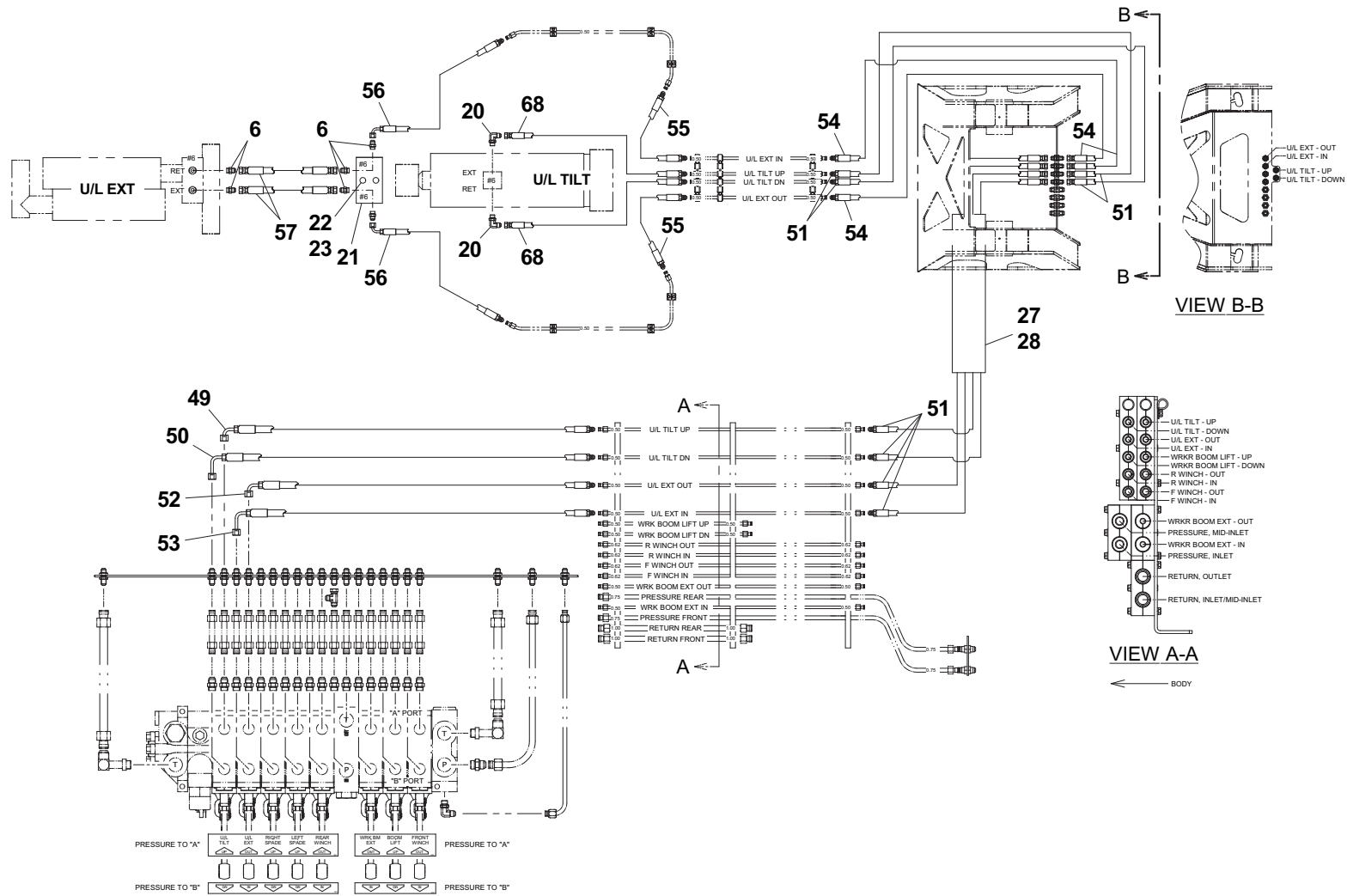



**THIS PAGE INTENTIONALLY LEFT BLANK**

**DRIVER SIDE HYDRAULIC PRESSURE GAUGES**

ITEM	PART NO.	DESCRIPTION	QTY
1	7443000026	Tee	2
2	4567110141	Hose Assembly	2
3	7445040421	Fitting	2
4	7470000004	Gauge, Pressure	2
5	7790060676	Screw, #6 x 0.38"	6
6	7330000257	Decal - Pressure Front Valve	1
7	7330000256	Decal - Pressure Rear Valve	1
8	4178000858	Bracket	1
9	7413000002	Nutsert, 0.25"-20 NC	2
10	7950140161	Flatwasher, 0.25" ID	2
11	7950140000	Lockwasher, 0.25" ID	2
12	7114140618	Capscrew, 0.25"-20NC x 0.75"	2

# DRIVER SIDE HYDRAULIC PRESSURE GAUGES

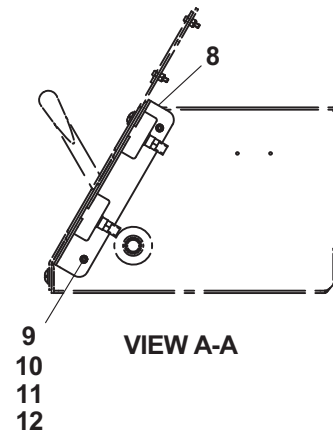
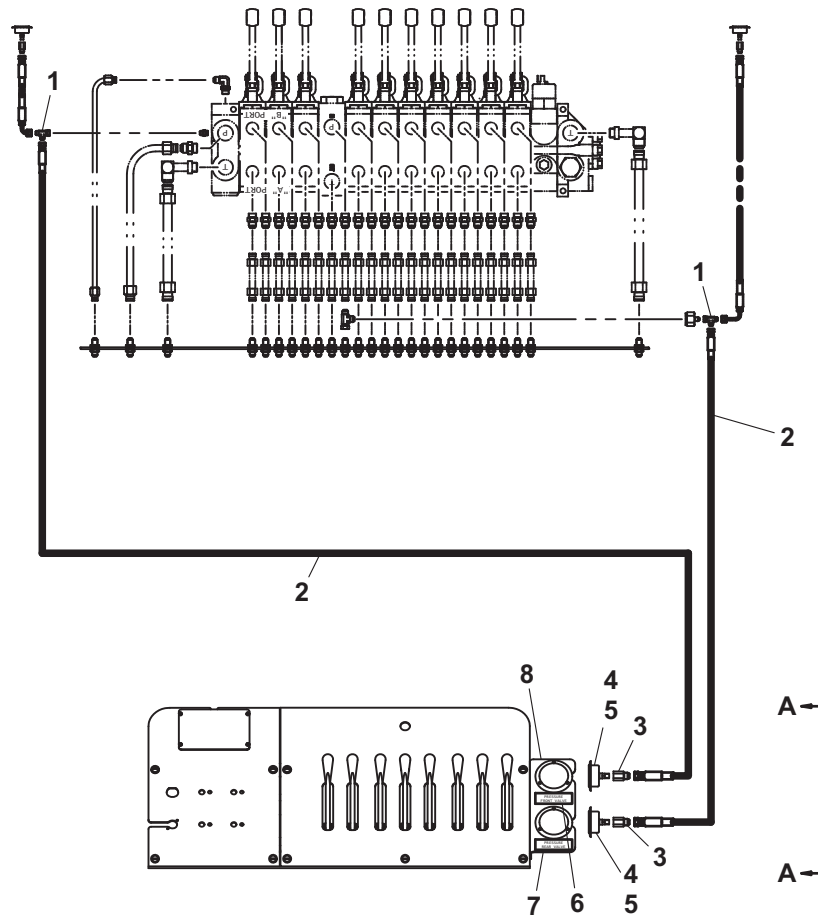

**PASSENGER SIDE WINCH AIR CONTROLS - 2 SPD GEAR SHIFT**

ITEM	PART NO.	DESCRIPTION	QTY
1	7443000154	Bushing	1
2	7443000155	Elbow	1
3	7443000156	Nipple	2
4	7443000152	Plug	1
5	7443000139	Elbow	8
6	7935000120	Valve, Pressure Protection	1
7	7443000175	Fitting	2
8	7295000029	Air Regulator	1
9	7443000066	Fitting	1
10	7470000006	Gauge, Air Pressure	1
11	7444020013	Plug	2
12	7443000173	Elbow	10
13	7446502518	Fitting, Bulkhead	1
14	7312000017	Coupling	1
15	7443000176	Fitting	2
16	7443000174	Tee	2
17	7565000016	Airline, Tubing 0.25 OD	150ft
18	7565000014	Airline, Tubing 0.38 OD	25ft
19	7443000149	Bushing	1
20	7443000178	Union	6
21	7935000136	Valve, Air	4
22	4619000005	Manifold	1
23	7660142601	Locknut, 0.25"-20NC	2
24	7115142450	Capscrew, 0.25"-20NC x 3.00"	2
25	7950140161	Flatwasher, 0.25" ID	4
26	7443000270	Tee	1
27	4811001135	Sheet	1
28	7114140518	Capscrew, 0.25"-20NC x 0.62"	4
29	7660142604	Locknut, 0.25"-20NC	4
30	7330000840	Decal - Front Winch Freespool	1
31	7330000841	Decal - Rear Winch Freespool	1
32	7330000842	Decal - Front Winch 2 Speed	1
33	7330000843	Decal - Rear Winch 2 Speed	1



# PASSENGER SIDE WINCH AIR CONTROLS - 2 SPD GEAR SHIFT

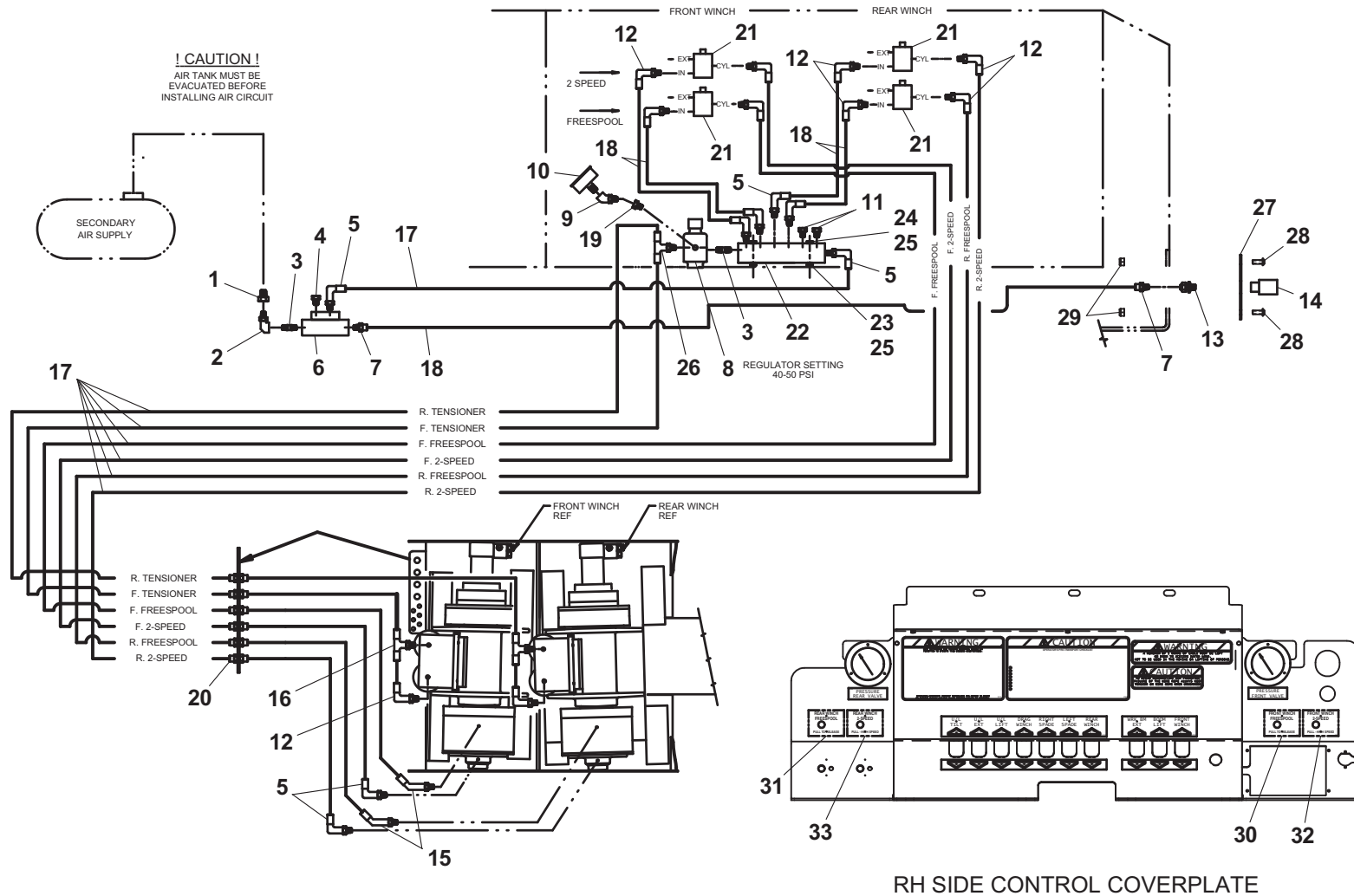

**DRIVER & PASSENGER SIDE WINCH AIR CONTROLS - DP 50K, 2 SPD GEAR SHIFT**

ITEM	PART NO.	DESCRIPTION	QTY
1	7443000154	Bushing	1
2	7443000155	Elbow	1
3	7443000156	Nipple	1
4	7935000120	Valve, Pressure Protection	1
5	7443000152	Plug	9
6	7443000139	Elbow	7
7	7443000175	Fitting	2
8	7565000014	Airline, Tubing 0.38 OD	25ft
9	7446502518	Fitting, Bulkhead	1
10	7312000017	Coupling	1
11	7565000016	Airline, Tubing 0.25 OD	250ft
12	7443000178	Union	25
13	7443000329	Fitting	7
14	7443000173	Elbow	26
15	7935000351	Valve, Air	8
16	7295000029	Air Regulator	1
17	7470000006	Gauge, Air Pressure	1
18	7443000174	Tee	3
19	7443000146	Elbow	1
20	4619000005	Manifold	1
21	7115142450	Capscrew, 0.25"-20NC x 3.00"	2
22	7660142601	Locknut, 0.25"-20NC	2
23	7950140161	Flatwasher, 0.25" ID	4
24	7443000287	Tee	4
25	7443000243	Fitting, Bulkhead	4
26	7444020014	Plug	2
27	7443000176	Fitting	2
28	7330000737	Decal - Front Winch Freespool	2
29	7330000738	Decal - Rear Winch Freespool	2
30	7330000739	Decal - Front Winch 2 Speed	2
31	7330000740	Decal - Rear Winch 2 Speed	2
32	7661000041	Nut, Panel	1

# DRIVER & PASSENGER SIDE WINCH AIR CONTROLS - DP 50K, 2 SPD GEAR SHIFT

**! CAUTION !**  
AIR TANK MUST BE EVACUATED BEFORE  
INSTALLING AIR CIRCUIT

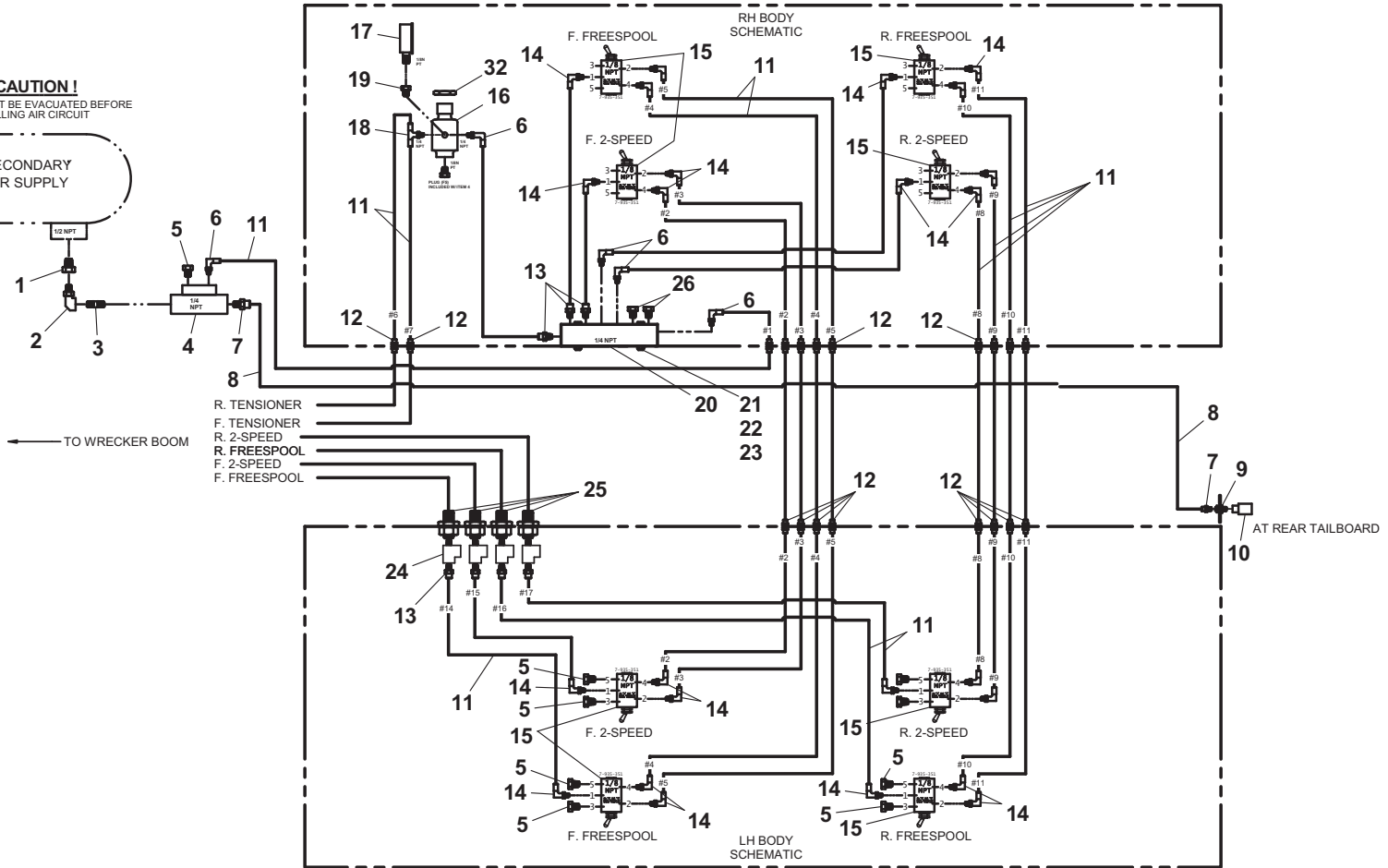
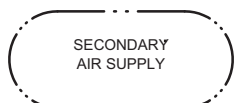

**DRIVER & PASSENGER SIDE WINCH AIR CONTROLS - DP 50K, 2 SPD GEAR SHIFT**

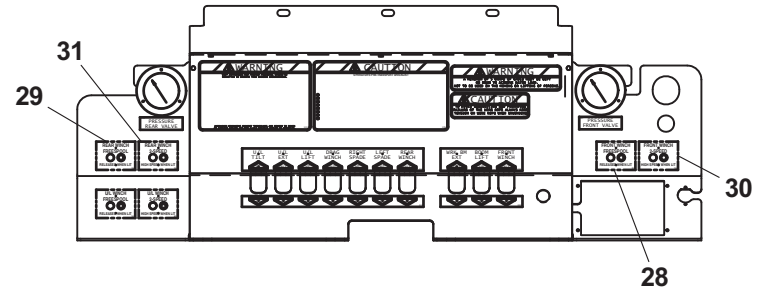
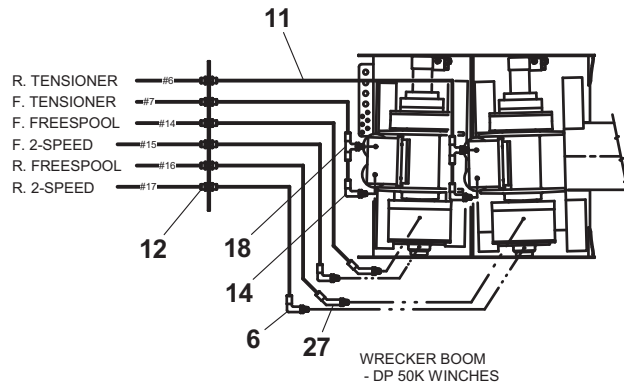

**RH CONTROL STATION**  
 DECAL INSTALLATION

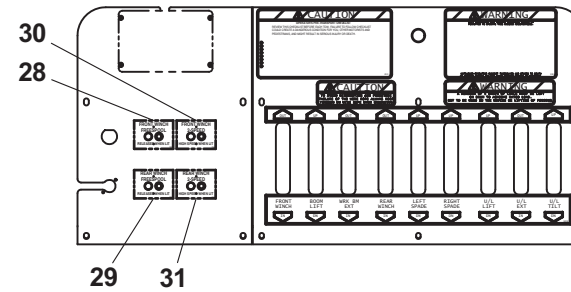

**RH CONTROL STATION**  
 DECAL INSTALLATION

**THIS PAGE INTENTIONALLY LEFT BLANK**

**DRIVER & PASSENGER SIDE WINCH AIR CONTROLS - DP 50K, RAMSEY 50K, 2 SPD MOTOR SHIFT**

ITEM	PART NO.	DESCRIPTION	QTY
1	7443000154	Bushing	1
2	7443000155	Elbow	1
3	7443000156	Nipple	1
4	7935000120	Valve, Pressure Protection	1
5	7443000152	Plug	5
6	7443000139	Elbow	5
7	7443000175	Fitting	2
8	7565000014	Airline, Tubing 0.38 OD	25ft
9	7446502518	Fitting, Bulkhead	1
10	7312000017	Coupling	1
11	7565000016	Airline, Tubing 0.25 OD	150ft
12	7443000178	Union	15
13	7443000329	Fitting	4
14	7443000173	Elbow	12
15	7935000351	Valve, Air	4
16	7295000029	Air Regulator	1
17	7470000006	Gauge, Air Pressure	1
18	7443000174	Tee	1
19	7443000146	Elbow	1
20	4619000005	Manifold	1
21	7115142450	Capscrew, 0.25"-20NC x 3.00"	2
22	7660142601	Locknut, 0.25"-20NC	2
23	7950140161	Flatwasher, 0.25" ID	4
24	7443000287	Tee	2
25	7443000456	Fitting, Bulkhead	2
26	7444020014	Plug	4
27	7443000176	Fitting	2
28	7330000737	Decal - Front Winch Freespool	2
29	7330000738	Decal - Rear Winch Freespool	2
30	7661000041	Nut, Panel	1



# DRIVER & PASSENGER SIDE WINCH AIR CONTROLS - DP 50K, RAMSEY 50K, 2 SPD MOTOR SHIFT

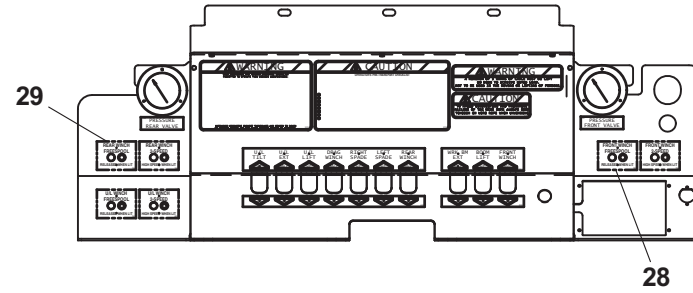

**RH CONTROL STATION**  
DECAL INSTALLATION

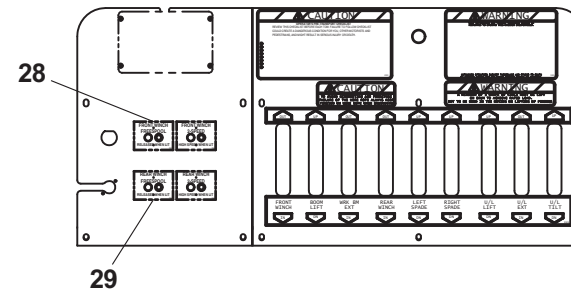
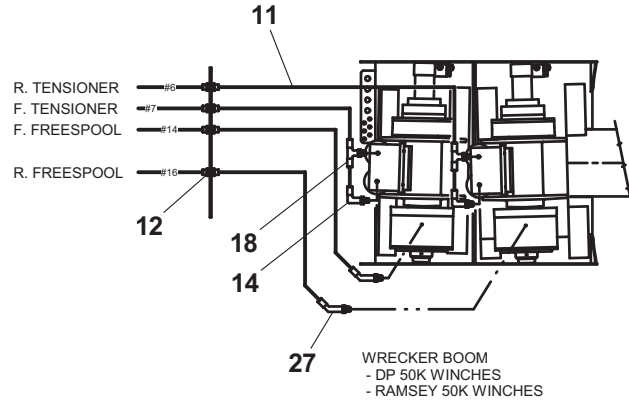

**LH CONTROL STATION**  
DECAL INSTALLATION



**THIS PAGE INTENTIONALLY LEFT BLANK**

**WINCH ELECTRIC SPEED CONTROLS - DP 50K, RAMSEY 50K, 2 SPD MOTOR SHIFT**

ITEM	PART NO.	DESCRIPTION	QTY
1	7345211702	Electrical Terminal	2
2	7346000039	Tubing, Heat Shrink	96in
3	3460000029	In-Line Fuse Holder	1
4	7345001714	Electrical Terminal	15
5	8977510200	Wire, 14GA. Red	50Ft
6	8594100002	Wire Loom	125Ft
7	7457000011	Fuse, 10 Amp	1
8	7346000275	Electrical Lock	2
9	7346000264	Electrical Connector	1
10	7345001710	Electrical Terminal	12
11	7870000145	Switch, Toggle	4
12	7590000364	Light	4
13	7330000739	Decal - Front Winch 2 Speed	2
14	7330000740	Decal - Rear Winch 2 Speed	2
15	8977010103	Wire, 16GA. - 2 Conductor	75ft
16	7346000273	Electrical Terminal	4
17	7346000274	Electrical Connector	2

# WINCH ELECTRIC SPEED CONTROLS - DP 50K, RAMSEY 50K, 2 SPD MOTOR SHIFT

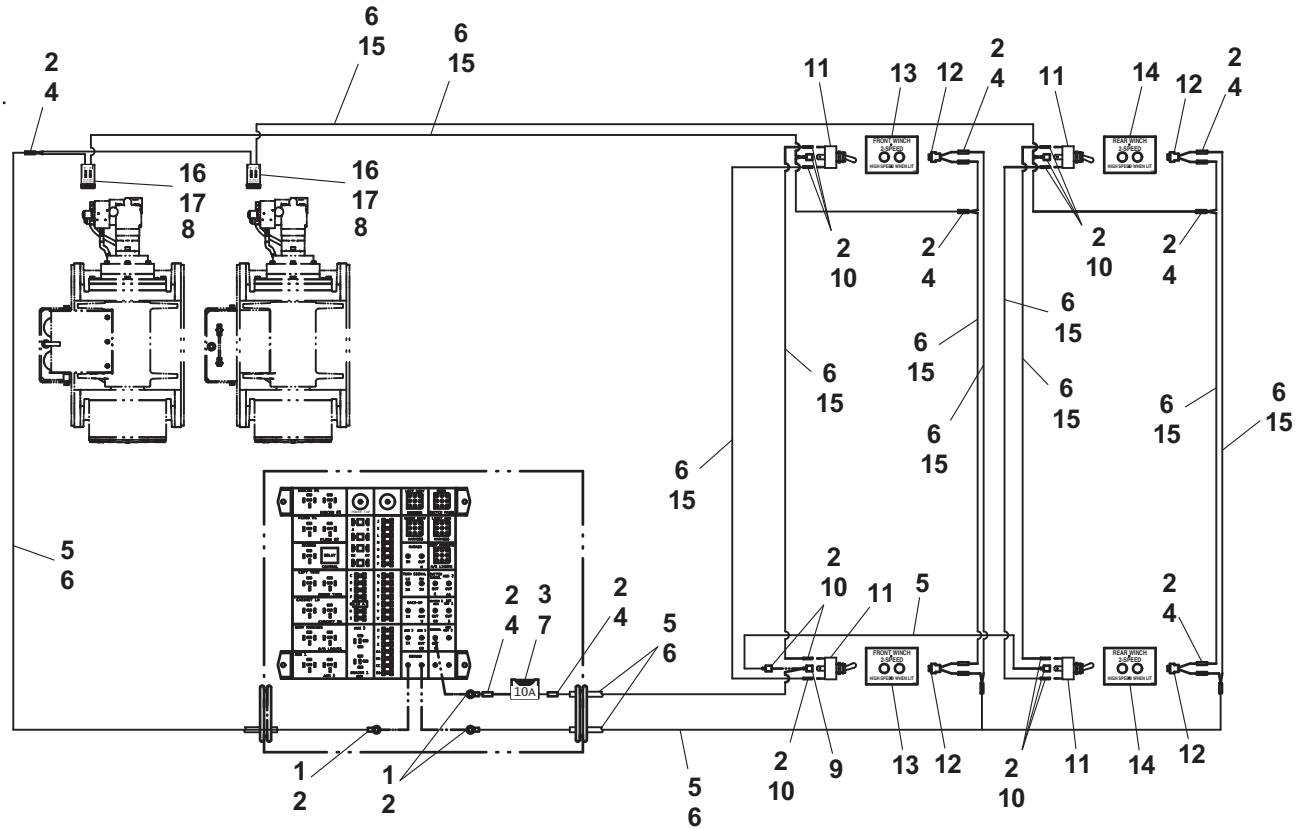

**WINCH ELECTRIC SPEED/FREE SPOOL CONTROLS - DP 50K, RAMSEY 50K, 2 SPD**

ITEM	PART NO.	DESCRIPTION	QTY	ITEM	PART NO.	DESCRIPTION	QTY
		<b>Motor Shift Winches</b>				<b>Gear Shift Winch</b>	
1	7870000136	Pressure Switch	2	1	7870000136	Pressure Switch	4
2	7590000364	Light	4	2	7590000364	Light	8
3	7346000039	Tubing, Heat Shrink	6in	3	7346000039	Tubing, Heat Shrink	12in
4	7552000414	Harness	1	4	7552000414	Harness	1
5	7552000415	Harness	1	5	7552000415	Harness	1
6	7457000019	Fuse, 5 Amp	1	6	7457000019	Fuse, 5 Amp	1

# WINCH ELECTRIC SPEED/FREE SPOOL CONTROLS - DP 50K, RAMSEY 50K, 2 SPD

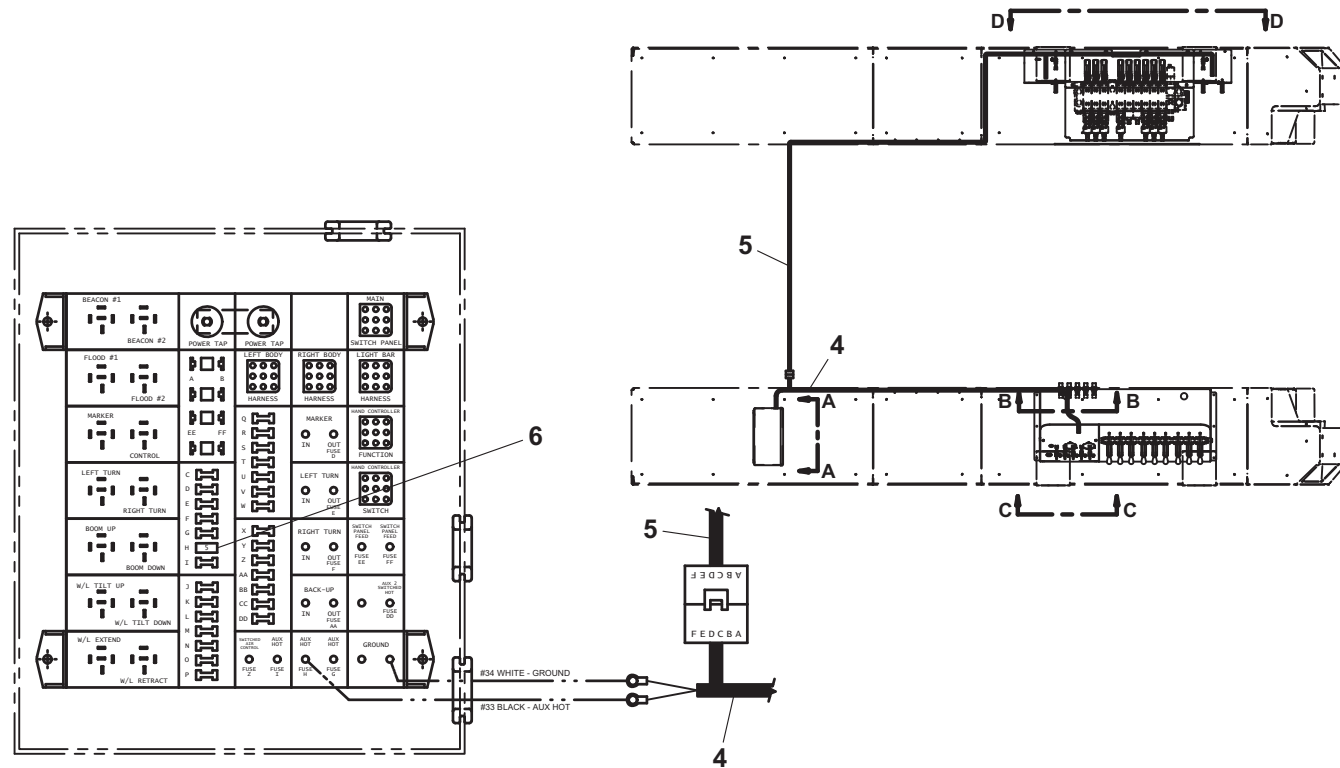

**VIEW A-A**  
DIST PANEL

**WINCH ELECTRIC SPEED/FREE SPOOL CONTROLS - DP 50K, RAMSEY 50K, 2 SPD**

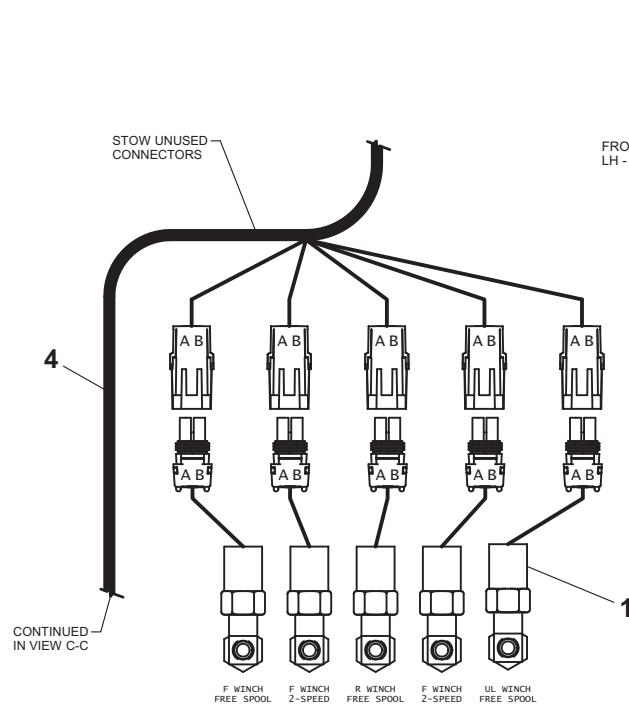

**VIEW B-B**  
PRESSURE SWITCH CONNECTIONS

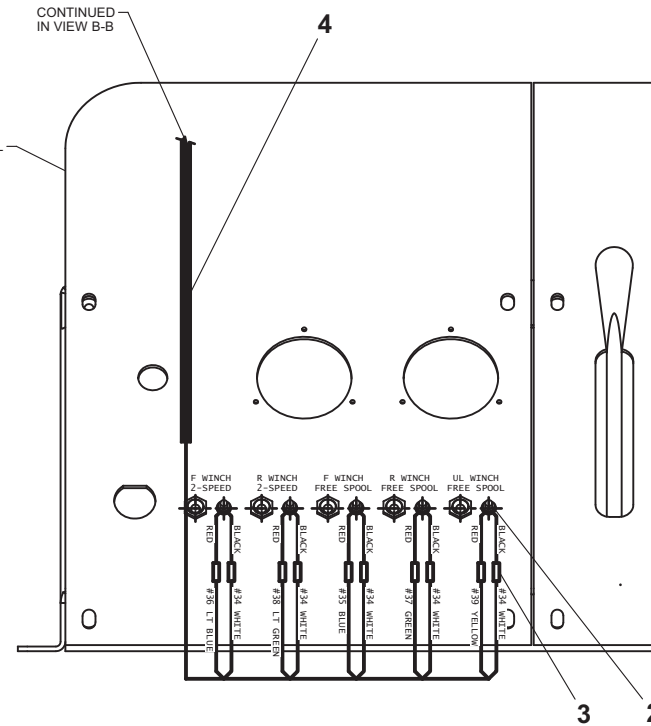

**VIEW C-C**  
LH CONTROL STATION

# WINCH ELECTRIC SPEED/FREE SPOOL CONTROLS - DP 50K, RAMSEY 50K, 2 SPD

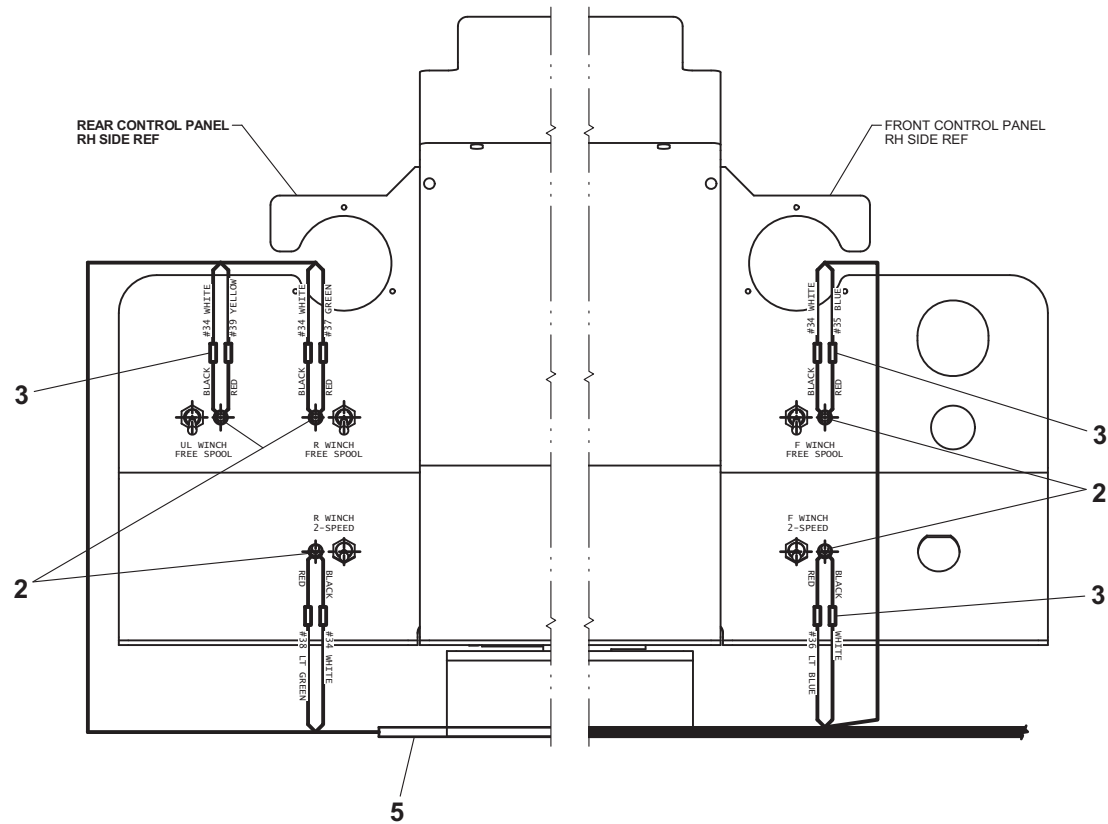

**VIEW D-D**  
RH CONTROL STATION

**DECALS**

ITEM	PART NO.	DESCRIPTION	QTY	ITEM	PART NO.	DESCRIPTION	QTY
1	7330000211	Decal - Safety Chains	1	33	7330000590	Decal - HDL 1000/530 (Red)	2
2	7330000122	Decal - Wheel Lift	1		7330000591	Decal - HDL 1000/530 (White)	
3	7330000599	Decal - Moving Parts	2		7330000592	Decal - HDL 1000/565 (Red)	
4	7330000193	Decal - Wheel Lift	2		7330000593	Decal - HDL 1000/565 (White)	
5	7330000202	Decal - Shock Warning	1				
6	7330000203	Decal - Shock Warning	2				
7	7330000034	Decal - Wheel Lift	1				
8	7330000108	Decal - Jerr-Dan Nameplate	2				
9	7330000197	Decal - Jerr-Dan (Red)	2				
	7330000533	Decal - Jerr-Dan (White)					
10	7330000297	Decal - Lubrication	1				
11	7330000189	Decal - Serial Number/Rating Placard	1				
12	7330000143	Decal - Made In The USA	1				
13	7759000004	Pop Rivet	10				
14	7330000717	Decal - Patent	1				
15	7330000208	Decal - Service Air	1				
16	7330000209	Decal - Supply Air	1				
17	7330000210	Decal - Auxiliary Air	1				
19	7330000139	Decal - Checklist Reminder	1				
20	7330000298	Decal - Lubrication	1				
21	7330000449	Decal - 50 Ton	2				
22	7330000827	Decal - 41 Ton	2				
23	7330000828	Decal - 26 Ton	2				
24	7330000829	Decal - 19 Ton	2				
25	7330000830	Decal - 15 Ton	2				
26	7330000453	Decal - Rating Arrow	2				
27	7330000846	Decal - 20 Ton (3 Piece Boom Only)	2				
28	7330000448	Decal - 39 Ton (3 Piece Boom Only)	2				
29	7330000850	Decal - 10 Ton (3 Piece Boom Only)	2				
30	7330000849	Decal - 11.5 Ton (3 Piece Boom Only)	2				
31	7330000848	Decal - 13 Ton (3 Piece Boom Only)	2				
32	7330000847	Decal - 14.5 Ton (3 Piece Boom Only)	2				



# DECALS

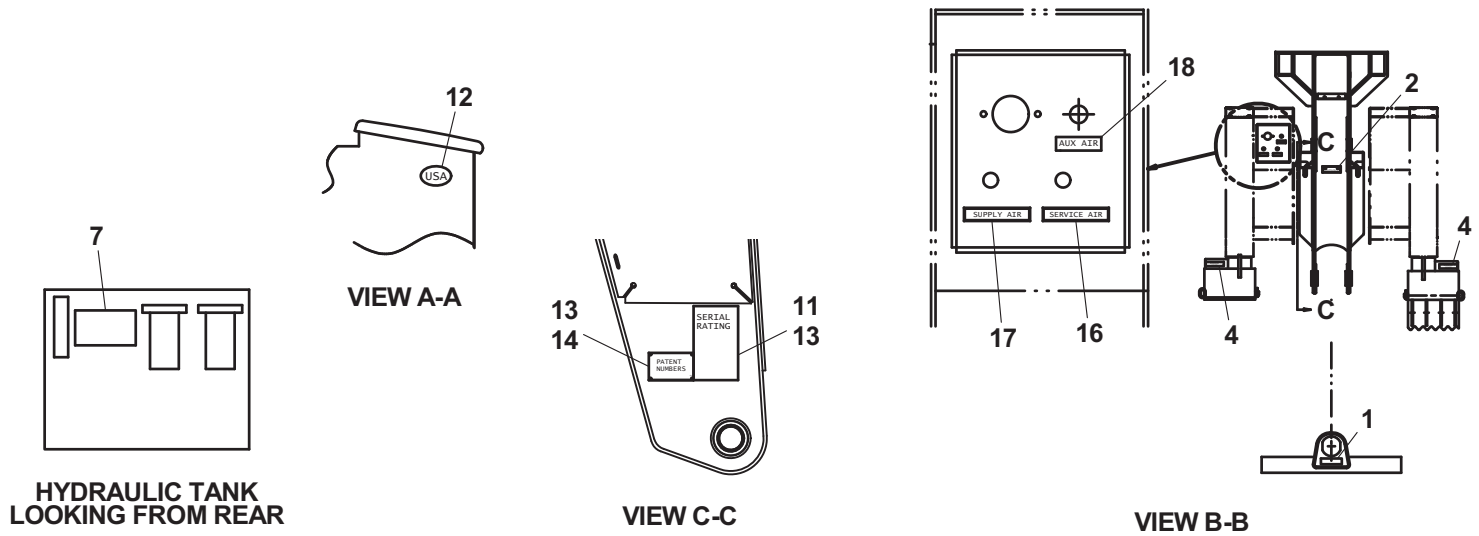
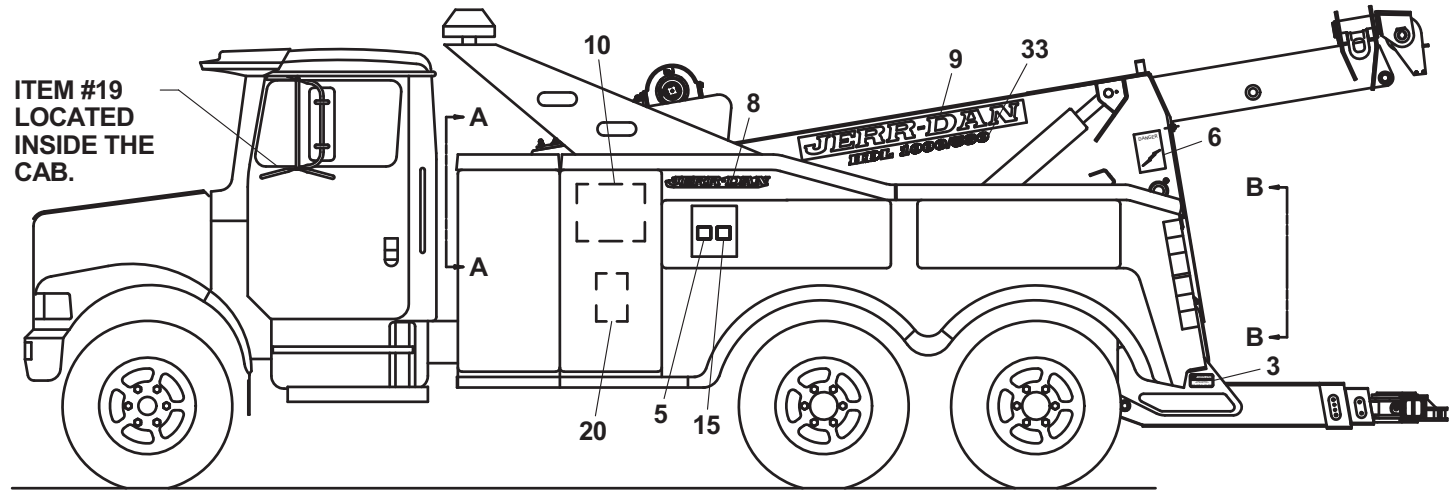

**DECALS**

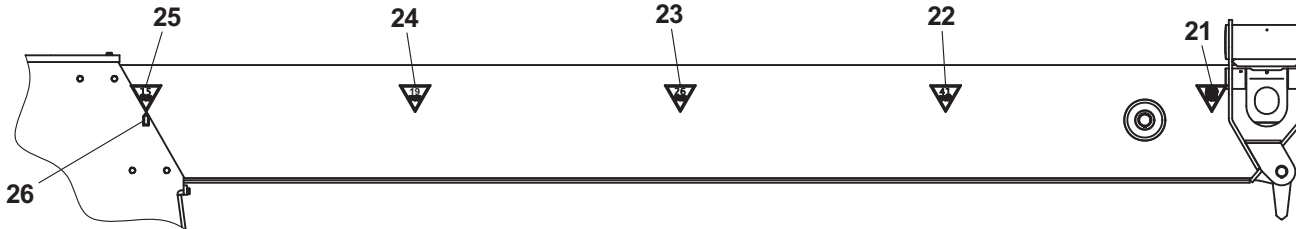

**2-PIECE WRECKER BOOM FLY**

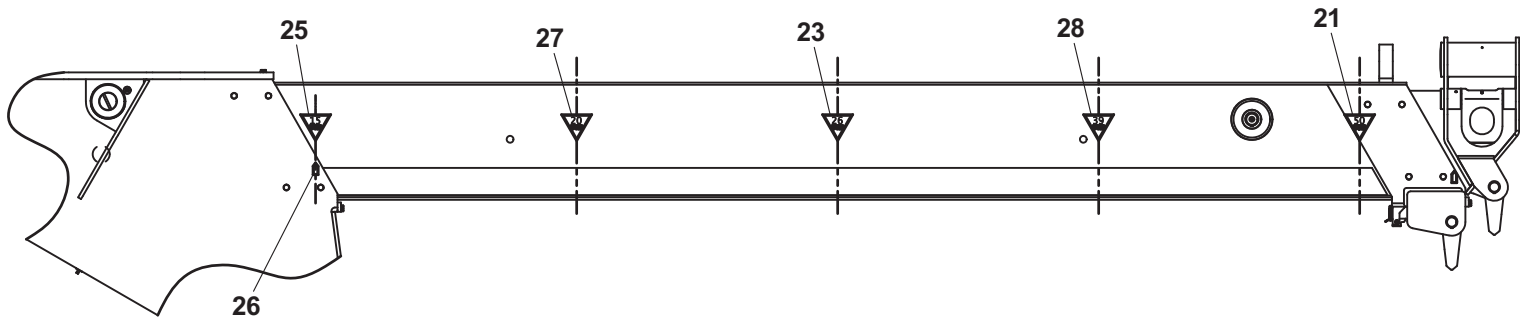

**3-PIECE WRECKER BOOM MID**

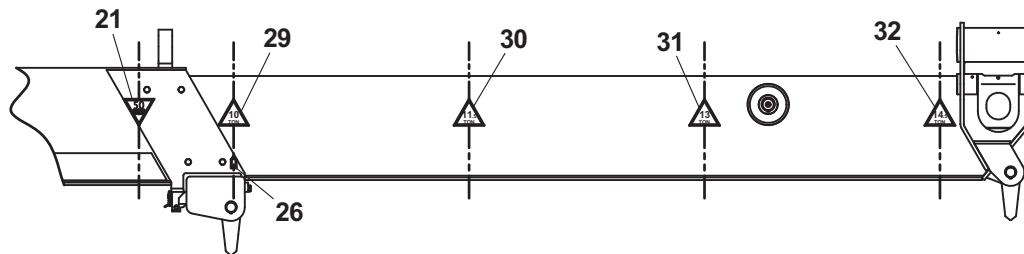

**3-PIECE WRECKER BOOM FLY**



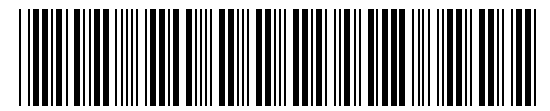

5376000143-0