

3 CAR CARRIER

OPERATIONS AND MAINTENANCE

MANUAL

5376000077

August 1, 2018

JERR-DAN[®]

An Oshkosh Corporation Company

13224 Fountainhead Plaza

Hagerstown, MD 21742

Phone (717) 597-7111

www.jerr-dan.com

 **WARNING**

Operating, servicing and maintaining this vehicle or equipment can expose you to chemicals including engine exhaust, carbon monoxide, phthalates, and lead, which are known to the State of California to cause cancer and birth defects or other reproductive harm. To minimize exposure, avoid breathing exhaust, do not idle the engine except as necessary, service your vehicle or equipment in a well-ventilated area and wear gloves or wash your hands frequently when servicing. For more information go to www.P65Warnings.ca.gov.

FOREWORD

This manual is intended to serve as a guide to the owner and operator in the safe operation and optimum performance of this Jerr-Dan equipment.

Establishment of good operating habits and familiarity with the equipment and its capabilities combined with good judgement are essential.

Before attempting to operate the unit carefully read all sections of this manual.

TABLE OF CONTENTS

Certification.....	0.1
Safety.....	1.1
Decal Group.....	1.5
Reporting Safety Defects.....	1.12
Operation	2.1
Maintenance and Lubrication	3.1
Lubrication Chart	3.3
Husco Valve	3.4
Troubleshooting	3.5

THIS PAGE INTENTIONALLY LEFT BLANK

JERR-DAN

An Oshkosh Corporation Company

Rev. _____

Date _____

NOTICE

MANUFACTURED BY:
DATE OF MANUFACTURE ____ mo. ____ yr.
INCOMPLETE VEHICLE MANUFACTURED BY:
DATE INC. VEH. MFD. ____ mo. ____ yr.
GVWR _____
GAWR FRONT _____ with _____ tires,
_____ rims, @ _____ psi cold _____
GAWR INTERMEDIATE (1) _____ with _____ tires,
_____ rims, @ _____ psi cold _____
GAWR INTERMEDIATE (2) _____ with _____ tires,
_____ rims, @ _____ psi cold _____
GAWR REAR _____ with _____ tires,
_____ rims, @ _____ psi cold _____

Conformity of the chassis-cab to Federal Motor Vehicle Safety Standards, which have been previously fully certified by the incomplete vehicle manufacturer or intermediate vehicle manufacture, has not been affected by final-stage manufacture. The vehicle has been completed in accordance with the prior manufacturer's instructions, where applicable. This vehicle conforms to all other applicable Federal Motor Vehicle Safety Standards in effect in:

_____ mo. ____ yr.

VEHICLE IDENTIFICATION NUMBER: _____

VEHICLE TYPE: _____

This certification sticker appears on every Jerr-Dan unit mounted on a new chassis and is required by law. Jerr-Dan Corporation will not certify any unit for a capacity greater than the chassis manufacturer's specified rating. **The capacity ratings of Jerr-Dan units do not imply that vehicles can be used without regard to gross vehicle weight ratings (GVWR) or gross axle rating limitations.**

The payload carrying capacity of any truck is determined by the GVWR of the cab chassis, the curb weight of the cab chassis and the weight of the body. It is important that you determine that your truck has satisfactory carrying capacity and axle ratings for your specific application. Jerr-Dan's authorized sales representatives are available to assist you in this regard.

JERR-DAN

An Oshkosh Corporation Company

Rev. _____

Date _____

THIS PAGE INTENTIONALLY LEFT BLANK

SAFETY

Safety is all-important when working with machinery. Accidents happen when established safety practices have been overlooked.

Read and practice all safety points listed in this manual. Safety is the prime responsibility of the operator.

1. Read operating and loading instructions thoroughly.
2. Become familiar with the loads that your unit can safely transport without exceeding the structural capacity of the Jerr-Dan equipment or the gross axle weight ratings, gross vehicle weight rating, and gross combined vehicle weight rating of your chassis.
3. Observe all warning decals.
4. Make sure you are clear of oncoming traffic. Dual controls (driver's side and passenger's side) are standard on your Jerr-Dan roll back.
5. Always put bumper on the ground to support the body and truck frame.

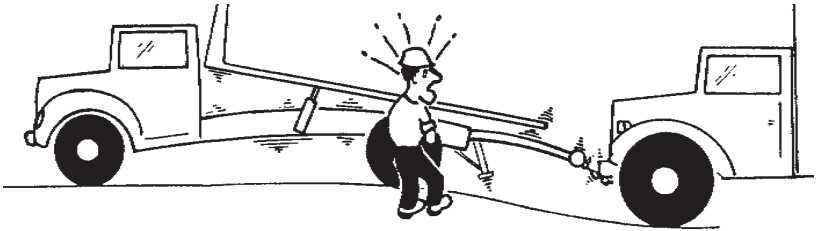

6. Never exceed the rated capacity of the body or truck chassis and it's components or use a tow option without a vehicle on the deck.

7. Never winch from the side of the bed. Winch only from the rear with load in line with the winch. Failure to do so can result in winch or wire rope damage. JERR-DAN DOES NOT RECOMMEND THE USE OF SIDE PULLING DEVICES.

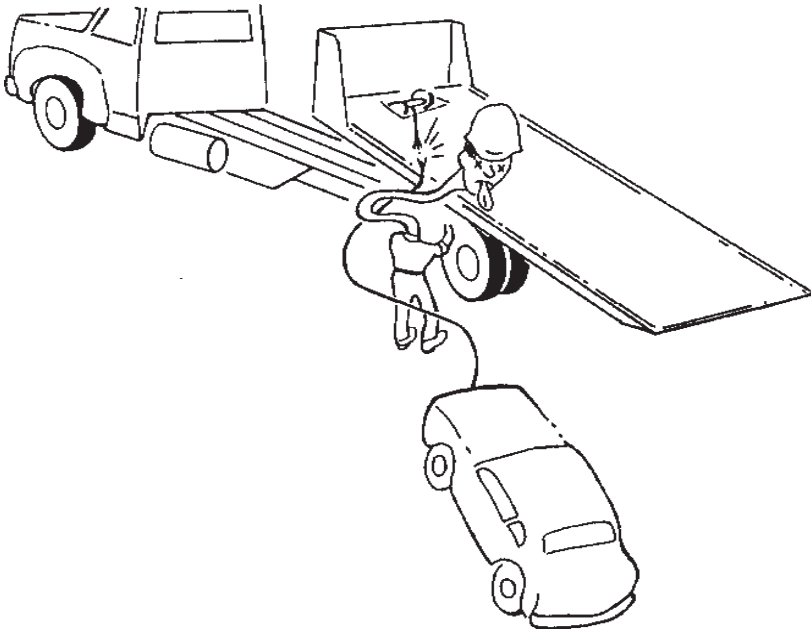

8. Always try to winch from the center of the load.
9. Maintain winch cable in good condition. Replace when worn, kinked or frayed. Do not use cable clamps.

10. When loading or unloading the deck and operating the winch, make certain the area behind the load is clear of personnel and obstacles.

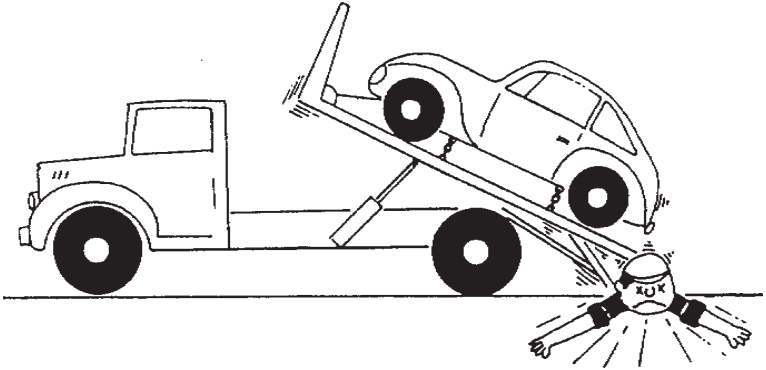

11. Distribute load evenly on the deck. Do not concentrate the load on one section of the deck, to the rear of the truck axles, or use a tow option without a load on the deck.

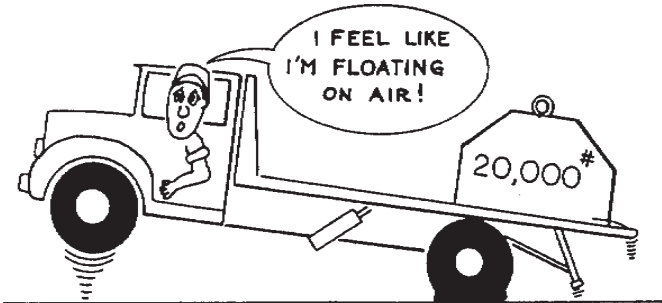

12. Secure cargo to the deck at both the front and rear before the truck is driven. Do not rely on the winch as the only means of holding the load.

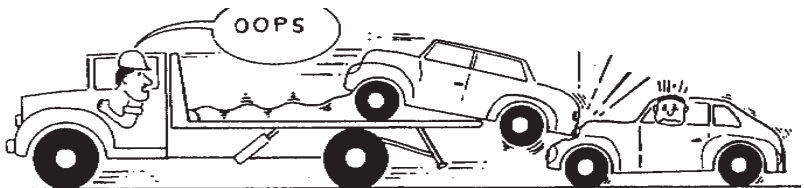

13. Keep alert. Do not be distracted during any operating sequences.
14. Do not work behind truck with vehicle on deck unless vehicle is secured at front of deck. (Do not rely on winch.)
15. Read and follow wheel lift instructions for proper towing.
16. Do not exceed tow option ratings. Overloading can cause unsafe steering and braking conditions.
17. Always use both wheel straps on wheel lift.

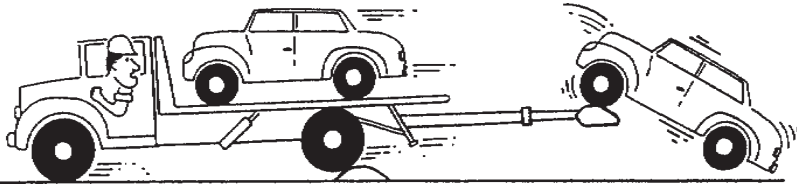

18. Use separate safety chains from towed vehicle to subframe for tow options. Always attach safety chains to the opposite side of the attaching point, crossing chains under the tow option. Allow enough slack in the chains to maneuver around corners without binding.
19. Insure deck is in the locked position before traveling.
20. Review operator's pre-transport checklist located on the headboard of the deck each time you move a vehicle.
21. Block up deck before performing any service or maintenance work under deck.

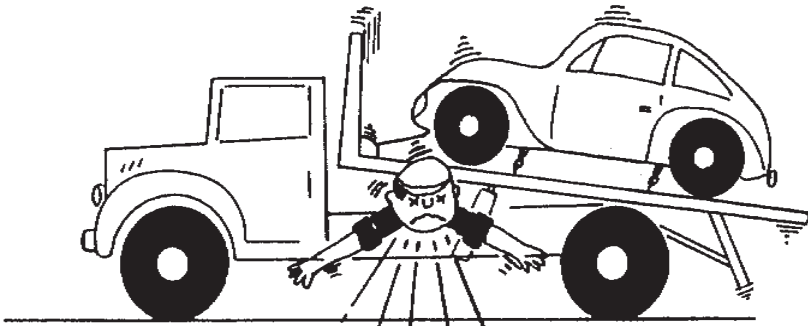

DECAL GROUP

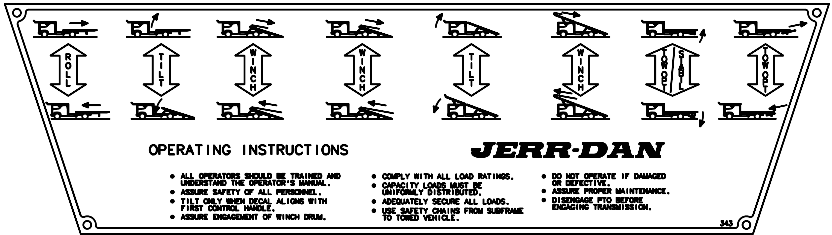

(STANDARD DECAL, LEFT SIDE)

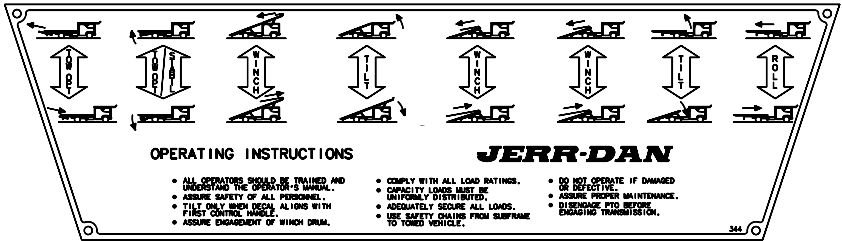

(STANDARD DECAL, RIGHT SIDE)

LUBRICATION CHART		INTERVAL (HOURS)	REF NO.	IDENTIFICATION	SERVICE	LUBRICANT	NO. OF POINTS
<p>JERR-DAN 3-CAR BIC ROLLBACK CARRIERS</p> <p>CHART COVERS JERR-DAN DECK SYSTEM ONLY</p> <ul style="list-style-type: none"> • INDICATES DUAL RANGE HYD. FLUID 5 W 20 AUTO TRANS FLUID MAY BE SUBSTITUTED IF NECESSARY <p>DO NOT GREASE SLIDE PADS</p>		50 OR MONTHLY	2	CABLE T - HANDLE	OIL OIL	ENGINE OIL ENGINE OIL	3 2
		100 OR BIMONTHLY	2	WINCH	LUBE	MPG	3
			4	SUBFRAME PIVOT	LUBE	MPG	4
			5	VALVE SPOOLS	CLEAN-OIL	ENGINE OIL	6 - 8
			6	HYD RESERVOIR	CHECK	*	1
			8	TILT CYLINDER	LUBE	MPG	8
			9	CYLINDER/LINK	LUBE	MPG	2
			10	STRUT/STAB ARM	LUBE	MPG	4
			11	BOOM EXT CYL	LUBE	MPG	2
			12	1RL/STAB CYL	LUBE	MPG	4
			13	CAM LOCK	LUBE	MPG	2
		14	WL/TB PIVOT	LUBE	MPG	1	
		250 OR SEMI-ANNUALLY	1	DECK GUIDES	BRUSH CHECK	*	4
			3	WINCH GEAR BOX	CHECK CHANGE	GL 5 #140	3
7	HYD FILTER		CHANGE	----	1		
1000 OPERATING HOURS	3	WINCH GEAR BOX	DRAIN/FILL	GL 5 #140	3		
	6	HYD RESERVOIR	DRAIN/FILL	*	1		

(LUBRICATION CHART)



WARNING

BOTH FRONT AND REAR TIE DOWNS MUST BE USED TO SECURE VEHICLE/LOAD TO DECK. DO NOT RELY ON THE WINCH AS THE ONLY MEANS OF HOLDING THE LOAD

CLUTCH MUST BE TOTALLY ENGAGED BEFORE STARTING THE WINCHING OPERATION

DO NOT DISENGAGE CLUTCH UNDER LOAD

DO NOT USE WINCH TO LIFT, SUPPORT, OR OTHERWISE TRANSPORT PEOPLE

A MINIMUM OF 5 WRAPS OF CABLE AROUND THE DRUM BARREL IS NECESSARY TO HOLD THE LOAD. CABLE SETSCREW IS NOT DESIGNED TO HOLD LOAD

(WINCH)



CAUTION

MAINTAIN OIL LEVEL WITHIN 1/2" OF TOP OF SIGHT GAUGE WITH ALL CYLINDERS FULLY RETRACTED. TORQUE SIGHT GAUGE BOLTS: 8 FT-LBS MAX.

272-02

(HYDRAULIC OIL LEVEL)

IDENT. NO.

MODEL

VERSION

MANUFACTURED BY:
JLG INDUSTRIES, INC.

FOR: **JERR-DAN**

UNDER ONE OR MORE OF THE FOLLOWING PATENTS:

5,133,633 5,575,606
5,697,741 5,722,810
5,951,235 6,231,294 B1
6,315,515 B1 6,336,783 B1
6,447,239 B2 7,264,305 B2

OTHER PATENTS PENDING

1001132766-A

(SUBFRAME ID)

MANUFACTURED BY:
JLG INDUSTRIES, INC.
FOR: **JERR-DAN**

SERIAL NO.

MODEL NO.

1001127221-00

(SERIAL NUMBER)

JERR-DAN

An Oshkosh Corporation Company

1.6

Rev. 1

Date 9/14



(DECK ALIGNMENT)



(TOW OPTION WARNING)



(WHEEL LIFT WARNING)



(TOW OPTION WARNING)

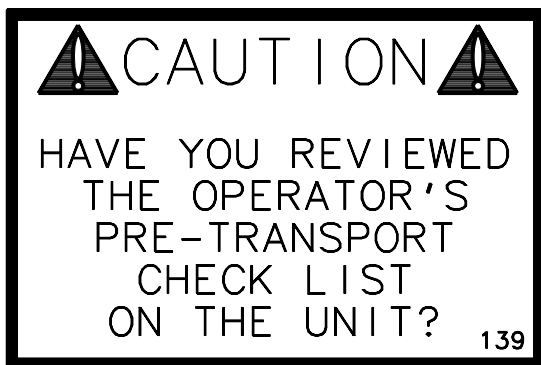

(CHECKLIST REMINDER)

OPERATOR'S
PRE-TRANSPORT CHECKLIST



CAUTION



REVIEW THIS CHECKLIST BEFORE EACH TOW. FAILURE TO FOLLOW CHECKLIST COULD CREATE A DANGEROUS CONDITION FOR YOU, OTHER MOTORISTS AND PEDESTRIANS, AND MIGHT RESULT IN SERIOUS INJURY OR DEATH.

VEHICLE ON DECK - CHECKLIST:

- HEED ALL WARNINGS ON EQUIPMENT AND CONTROLS.
- DO NOT HOOK CABLE HOOK DIRECTLY TO VEHICLE. USE A HOOK-UP CHAIN, V-STRAP/V-CHAIN ASSEMBLY.
- IS VEHICLE ON DECK ENGINE FORWARD TO AVOID UNLOADING FRONT AXLE OF CHASSIS?
- ARE TWO (2) REAR TIE-DOWN J-HOOKS OR CHAINS SECURELY ATTACHED TO VEHICLE AND DECK?
- IS TOWED VEHICLE IN PARK OR IN GEAR WITH EMERGENCY BRAKE APPLIED?
- DID YOU ATTACH FRONT SAFETY CHAIN/STRAPS TO VEHICLE?
- DO NOT OVERLOAD! SEE LOAD RATING PLACARD ON UNIT. STOP VEHICLE AT ONCE AND REARRANGE LOAD IF YOU NOTICE FRONT END OF TRUCK FEELS LIGHT OR BOUNCES EXCESSIVELY OR IF STEERING FEELS EXCESSIVELY LIGHT. LOSS OF VEHICLE CONTROL CAN RESULT FROM AN OVERLOAD AND CAN CAUSE A SERIOUS ACCIDENT.

VEHICLE ON TOW BAR - CHECKLIST:

- DO NOT LIFT OR TOW A VEHICLE USING THE WHEELIFT SYSTEM UNLESS THERE IS A VEHICLE ON THE DECK.
- DO YOU HAVE TURNING CLEARANCE ON TOWED VEHICLE?
- IS GROUND CLEARANCE SET FOR PROPER TOWING OF SECOND VEHICLE?
- ARE T-HANDLES TIGHTENED SO THAT GRIDS DO NOT MOVE DURING TRANSPORT?
- ARE BOTH WHEEL STRAPS ON TOWED VEHICLE AND TIGHTENED DOWN?
- ARE BOTH SAFETY CHAINS ATTACHED FROM TOWING TRUCK TO TOWED VEHICLE?
- ARE AUXILIARY TOWING LIGHTS ATTACHED TO TOWED VEHICLE?
- DO NOT OVERLOAD YOUR VEHICLE!

© COPYRIGHT 1992 JERR-DAN CORPORATION 275

(CHECKLIST)

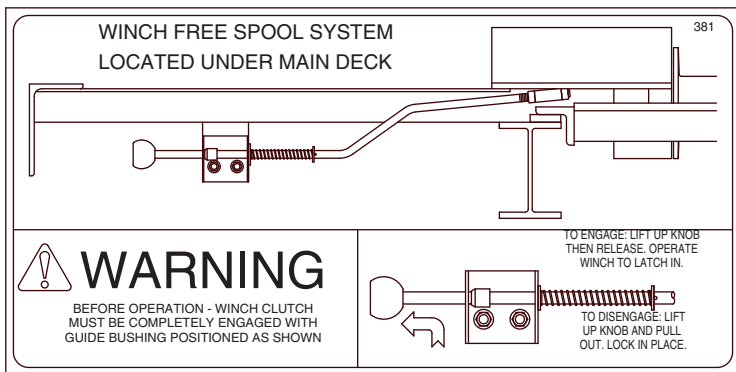

(FREE-SPOOL OPERATION)

SLIDE PAD LUBRICATION

INITIAL LUBRICATION:
LIGHT COAT OF ENGINE OR HYDRAULIC OIL
ON SLIDE PADS OR BEAM SURFACES.

MAINTENANCE:
NO FURTHER LUBRICATION OF SLIDE PADS IS
NECESSARY. KEEP DECK BEAM SURFACES CLEAN.

317

(SLIDE PAD LUBRICATION)

WARNING

WINCH ORBIT MOTOR FITTINGS WILL INTERFERE WITH NYLON CABLE TRACK SYSTEM UPON INSTALLATION AND REMOVAL OF DECK.

DO NOT INSTALL ORBIT MOTOR FITTINGS INTO ORBIT MOTOR TILL DECK IS SLID COMPLETELY ONTO SUBFRAME.

REMOVE ORBIT MOTOR FITTINGS PRIOR TO REMOVING DECK FROM SUBFRAME.

330

(ORBIT MOTOR FITTINGS WARNING)

MANUFACTURED BY: JLG INDUSTRIES, INC.

FOR: **JERR-DAN**

An Oshkosh Corporation Company

13224 Fountainhead Plaza

Hagerstown, MD 21742

Phone (717) 597-7111

www.jerr-dan.com

MODEL NUMBER:

SERIAL NUMBER:

STRUCTURAL CAPACITIES*

MAIN DECK CAPACITY: LBS.*

UPPER DECK CAPACITY: LBS.*

WHEELLIFT/TOWBAR LIFT CAPACITY:
(FULL EXTENSION)

LBS.*

WHEELLIFT/TOWBAR TOW CAPACITY:

LBS.*

HITCH OPTION TONGUE CAPACITY:
(FULL RETRACTION)

LBS.*

HITCH OPTION TONGUE CAPACITY:

LBS.*

***PLEASE READ THE FOLLOWING IN
ORDER TO ENSURE SAFE AND
CORRECT USE OF THE EQUIPMENT.**

DO NOT EXCEED THE ABOVE STRUCTURAL RATINGS.

THE MAXIMUM EFFECTIVE TRANSPORT LOAD
MAY BE LIMITED BY THE GAWR, GVWR OR GCWR
OF THE TRUCK CHASSIS.

THE MAXIMUM EFFECTIVE TRANSPORT LOAD MAY BE
LIMITED BY THE RATINGS OF ANY TOW IMPLEMENTS,
ATTACHMENTS, OR ACCESSORIES BEING USED.

WHEN SUPPLIED, THE SAFETY LOCKING PIN
MUST BE IN PLACE DURING TRANSPORT TO
ACHIEVE THE RATINGS LISTED ABOVE.

SAFETY IS NO ACCIDENT. REVIEW OPERATOR'S
PRE-TRANSPORT CHECKLIST ON VEHICLE AND IN THE
OWNERS MANUAL EACH TIME YOU MOVE A VEHICLE.
FOLLOW ALL INSTRUCTIONS ON CONTROLS AND UNIT.

1001132765-A

(STRUCTURAL RATING PLACARD)

JERR-DAN

An Oshkosh Corporation Company

1.11

Rev. 1

Date 9/14

REPORTING SAFETY DEFECTS

If you believe that your vehicle has a defect which could cause a crash or could cause injury or death, you should immediately inform the National Highway Traffic Safety Administration (NHTSA) in addition to notifying Jerr-Dan Corporation.

If NHTSA receives similar complaints, it opens an investigation, and if it finds that a safety defect exists in a group of vehicles, it may order a recall and remedy campaign. However, NHTSA cannot become involved in individual problems between you, your dealer, or Jerr-Dan Corporation.

To contact NHTSA, you may call the Vehicle Safety Hotline toll-free at 1-888-327-4236 (TTY: 1-800-424-9153); go to <http://www.safercar.gov>; or write to:

Administrator
NHTSA
400 Seventh Street S.W.
Washington, DC 20590

You can also obtain other information about motor vehicle safety from <http://www.safercar.gov>.

OPERATION

A. Controls

The operating controls for the Jerr-Dan equipment are conveniently located on both the driver's and passenger's side.

All operators must be trained and understand the contents of the operator's manual before operating any controls.

Assure adequate operating clearance and the safety of all personnel before operating the rollback equipment.

The following controls are provided:

1. Power-take-off (in truck cab)
2. Auxiliary engine throttle control (in truck cab)
3. Rollback control (first handle in control station)
4. Tilt control, lower deck (second handle in control station)
5. Winch control, lower deck front winch (third handle in control station)
6. Winch control, lower deck rear winch (fourth handle in control station)
7. Tilt control, upper deck (fifth handle in control station)
8. Winch control, upper deck (sixth handle in control station)
9. Tow option/Stabilizer, up/down (seventh handle in control station)
10. Tow option, in/out (eighth handle in control station)

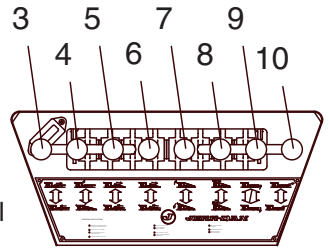

B. Loading the Deck

1. Position

Park the truck with the rear of the deck approximately 12 feet from the object to be loaded and in line with that object.

CAUTION: The unit should always be loaded and unloaded on level and stable ground.



JERR-DAN

An Oshkosh Corporation Company

- 1a. Set the parking brake.
- 1b. With the engine running, engage the PTO per instructions in the truck cab or in the PTO Operating Manual.
- 1c. Set the auxiliary throttle. After operating the unit several times, one will establish a feel for the optimum speed. **DO NOT OVERSPEED.**

2. Roll

Raise the rollback handle and the deck will slide back. Roll the deck rearward approximately 12 inches to clear the mechanical hold downs at the front of the frame. A decal is provided on the rubrail to aid in determining the amount to roll. Align the decal pointer with the roll (first) control handle.

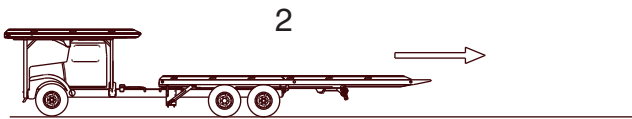

3. Tilt

Raise the tilt control lever, raising the forward end of the deck until the rear bumper rests firmly on the ground.

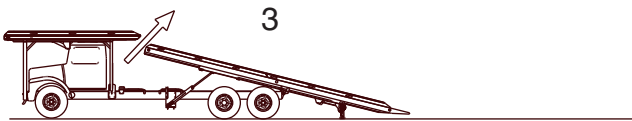

4. Roll

Raise the roll handle and the deck will slide back. Continue this operation until the approach plate of the deck has contacted the ground. Make sure that the rear bumper and the approach plate are both in firm contact with the ground before loading. There should be an equal weight distribution between the rear bumper and the end of the deck.

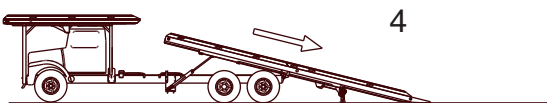

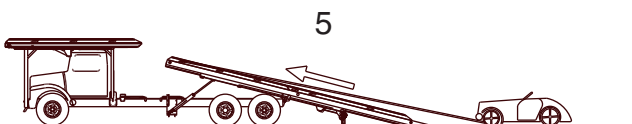

5. Winch

Winch the load onto the deck. Refer to the Winch Operation Manual for specific winch operation procedures.





- 5a. Raise the winch control handle to power unreel the winch cable while a second person keeps the cable taut or disengages the winch clutch and free spool the cable. (See the Winch Operation Manual for proper clutch disengagement procedures)
- 5b. Engage the winch clutch if the winch cable was free spooled. Raise the winch handle (unreel the cable) until the winch clutch fully engages. Ensure that the winch clutch is fully engaged before putting a load on the winch.
- 5c. Attach the winch cable to the load. The winch cable should be attached as close to the center of the load as possible. It may be necessary to use a "V" chain or other implement to attach the winch cable to the load.
- 5d. Lower the Winch control handle to wind the cable onto the winch drum and pull the load onto the deck.

 **CAUTION:** Never disengage the winch clutch when the winch is under load.

 **CAUTION:** Always maintain a minimum of 5 wraps of cable on the winch drum.

 **CAUTION:** Always winch load onto deck, **NEVER** drive equipment onto the tilted deck.

 **CAUTION:** Always maintain a uniform wrap of cable on the drum. "Nesting" of the winch cable may cause damage or premature wear of the winch cable.

 **CAUTION:** Remember that cables break, winches fail, and hooks become disengaged. **DO NOT WORK BELOW THE LOAD!**

 **CAUTION:** Replace worn or damaged cables. Always wear gloves when handling cable. **DO NOT USE CABLE CLAMPS.**

 **CAUTION:** The winch cable should remain attached to the load and taut.

6. Secure Load

Once the load is positioned on the deck secure it from movement in all directions. Set the parking brake or use wheel chocks if applicable.

7. Roll

Lower the roll control handle to roll the deck forward until the deck is in the proper position for tilting. The deck is in the proper position for tilting when the decal pointer is aligned with or just behind the roll (first) control handle.

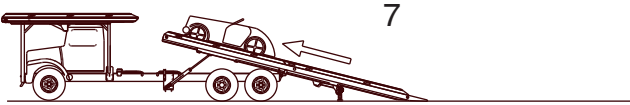

8. Tilt

Lower the tilt control handle to lower the front of the deck until the deck lays flat on the slide pads on the hold down.

NOTE: Tilting deck when fully forward will cause damage to the hold downs.

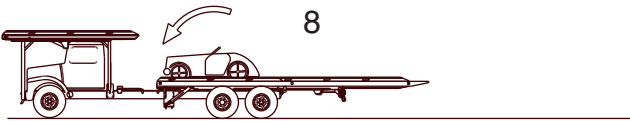

9. Roll

Lower the roll control handle to roll the deck forward until it is in the full forward position and under the hold downs.

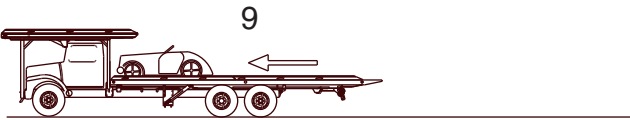

10. Secure Load

All loads must be secured from movement in all directions using safety tie-downs. Jerr-Dan provides straps and chains suitable for securing most vehicles to the deck. Vehicles should be secured at all four corners using safety tie-downs. Set brakes (if a vehicle) and use wheel blocks and tie-downs for safe transport. **Refer to the AAA or vehicle manufacturers towing manual for correct attachment points.**

⚠ CAUTION: Use safety tie-downs to secure the load against rearward motion. Leave the winch cable attached to the load and taut, but do not rely on the winch cable to secure the load.

11. Disconnect PTO

Return the engine to normal idle speed and disengage the PTO before engaging the transmission. Driving the truck with the PTO engaged will cause overspeeding. Overspeeding of the PTO and/or pump will greatly shorten their life and can cause damage to the PTO, pump, and transmission.

C. Unloading the Deck

1. Position

Park the truck with the rear of the deck approximately 12 feet from desired position of vehicle being unloaded.

- 1a. Set the parking brake.
- 1b. With the engine running, engage the PTO per instructions in the truck cab.
- 1c. Set the auxiliary throttle. After operating the unit several times one will establish a feel for the optimum speed. **DO NOT OVERSPEED.**
- 1d. Partially release bindings of the load but maintain restraint against movement of the load in any direction.

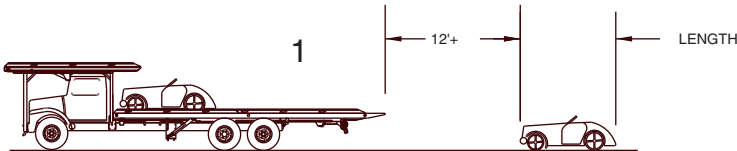

2. Roll

Raise the rollback handle and the deck will slide back. Roll the deck rearward approximately 12 inches to clear the mechanical hold downs at the front of the frame. A decal is provided on the rubrail to aid in determining the amount to roll. Align the decal pointer with the roll (first) control handle.

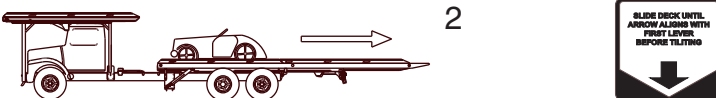

3. Tilt

Raise the tilt control handle, raising the forward end of the deck until the rear bumper rests firmly on the ground.

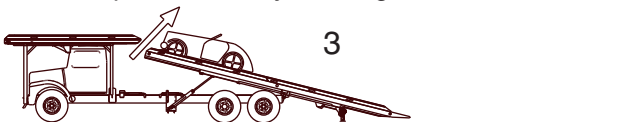

4. Roll

Raise the roll handle and the deck will slide back. Continue this operation until the approach plate has contacted the ground. Make sure that the rear bumper and the approach plate are both in firm contact with the ground before unloading. There should be an equal weight distribution between the rear bumper and the end of the deck.

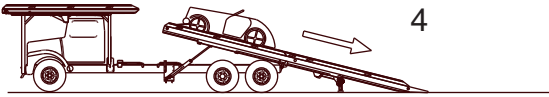

5. Winch

Winch the load off of the deck. Refer to the Winch Operation Manual for specific winch operation procedures.

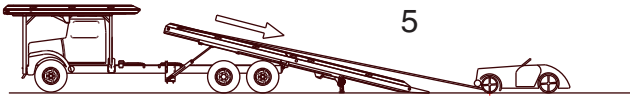

- 5a. Ensure that the winch cable is securely attached to the load and is taut. Ensure that the winch clutch is fully engaged (the winch is NOT in free spool mode.)
- 5b. Remove all equipment used to secure the load to the deck (excluding the winch cable). Release brakes of the load (if applicable).
- 5c. Raise the winch control to power unreel the cable from the drum, lowering the load from the deck.
- 5d. Secure the load on the ground. Remove the winch cable from the load and store the cable.

⚠ CAUTION: Never disengage the winch clutch when the winch is under load.

⚠ CAUTION: Always maintain a minimum of 5 wraps of cable on the winch drum.

⚠ CAUTION: Always winch load off of the deck, NEVER drive equipment on the tilted deck.

! CAUTION: Always maintain a uniform wrap of cable on the drum. “Nesting” of the winch cable may cause damage or premature wear of the winch cable.

! CAUTION: Remember that cables break, winches fail, and hooks become disengaged. **DON'T WORK BELOW THE LOAD!**

! CAUTION: Replace worn or damaged cables. Always wear gloves when handling cable. **DO NOT USE CABLE CLAMPS!**

D. LOADING THE OVERCAB DECK

1. POSITION

Position the truck with the rear of the deck approximately 12 feet from the object to be loaded and in line with that object.

! CAUTION: The unit should always be loaded and unloaded on level and stable ground.



- 1a. Set the parking brake.
- 1b. With the engine running, engage the PTO per instructions in the truck cab or in the PTO Operating Manual.
- 1c. Set the auxiliary throttle. After operating the unit several times, one will establish a feel for the optimum speed. **DO NOT OVERSPEED.**

2. Roll

Raise the rollback handle (first lever) and the deck will slide back. Roll the deck rearward approximately 12 inches to clear the mechanical hold downs at the front of the frame. A decal is provided on the rubrail to aid in determining the amount to roll. Align the decal pointer with the roll (first) control handle.



3. Tilt

Raise the tilt control lever (second lever), raising the forward end of the deck until the rear bumper rests firmly on the ground.

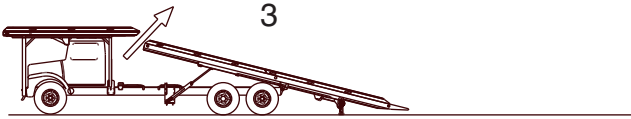

4. Roll

Raise the roll handle (first lever) and the deck will slide back. Continue this operation until the approach plate of the deck has contacted the ground. Make sure that the rear bumper and the approach plate are both in firm contact with the ground before loading. There should be an equal weight distribution between the rear bumper and the end of the deck.

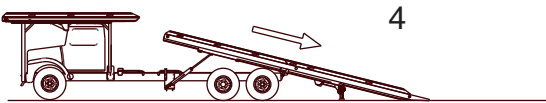

5. Tilt (upper deck)

Raise the tilt control lever (fifth lever) for the upper deck. This will raise the front end of the upper deck, raise fully. Free-spool the upper winch and hook up to the equipment to be loaded.

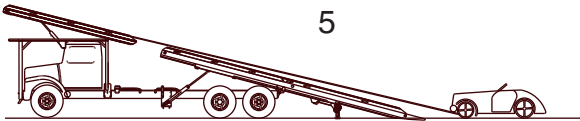

****Note that tilting the upper deck will leave a gap between the upper and lower decks.**

6. Winch (upper deck)

Using the upper deck winch lever (sixth lever), winch the load up the lower deck approximately three quarters of the way.

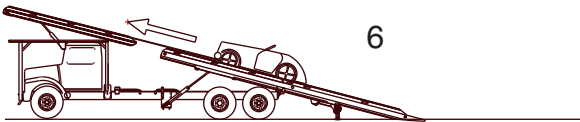

7. Roll (lower deck)

Raise the roll handle (first lever) and move the lower deck in line with the upper deck. This will let the load slide backwards on the deck. The upper and lower deck surfaces should be in alignment. Be careful not to run the lower deck into the upper deck. The two decks should barely touch.

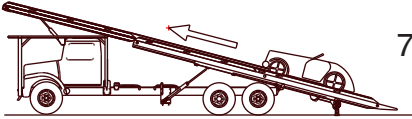

8. Winch (upper deck)

Using the upper deck winch lever (sixth lever), winch the load up to the tire stops of the upper deck. Keep the winch cable taut at this point.

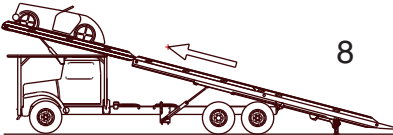

9. Tilt (upper deck)

Tilt the upper deck down to its original position. After upper deck is in its stowed position, secure the load to the upper deck. Never rely solely on the winch to hold the load. At this point the lower deck can either be returned to its stowed position or can be loaded as shown previously.

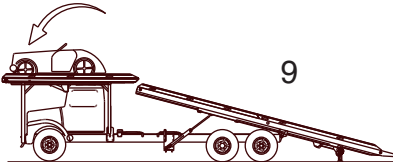

E. Unloading (upper deck)

Note: The main deck should be empty prior to unloading the top deck.

1. Tilting

Tilt the upper deck and the lower deck into alignment. Assure that the upper deck winch cable is taut. Be sure that the load is partially unsecured prior to tilting, but maintain restraint against movement in every direction.

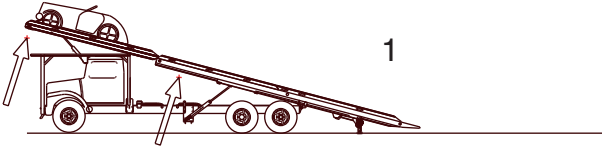

2. Winch (upper deck)

Release the remaining bindings, except for the winch cable. Winch the load down onto the main deck until it is centered about half way on the main deck.

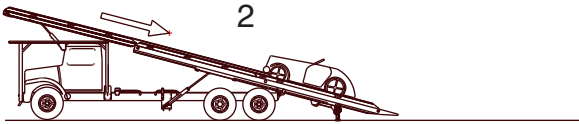

3. Roll, Tilt, and Winch

Roll and tilt the lower deck until the approach tip and the bumper tubes are firmly on the ground. Using the upper winch control, winch the load safely to the ground. Block the vehicle or apply the emergency brake after the load is safely on the ground.

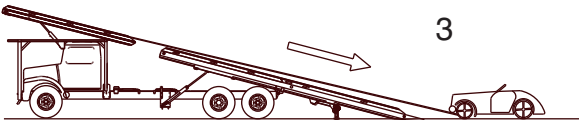

4. Finish

Finish the process by winching the cable back onto the upper deck winch. Then tilt the upper deck back into its stowed position. Proceed to do the same process with the lower deck. Be sure that all chains, binders etc. are secured in a toolbox prior to driving. Be sure that the pto is disengaged prior to driving, as this may cause damage to the PTO.

F. Operation of the Wheel Lift (Option)

The wheel lift allows an additional vehicle to be towed damage free on its own suspension by utilizing a wheel grid similar to the Jerr-Dan HPL wheel lift. The wheel lift cross bar may also be used as a conventional tow bar for badly damaged or heavier vehicles.

CAUTION: Because of the additional boom extension and load point of the towed vehicle, the wheel lift places more load on the rear axle and unloads the front axle more than a conventional tow bar. Overloading the wheel lift may result in unsafe steering and braking conditions and may damage the truck frame. Also, never use the wheel lift without a vehicle on the deck. Single vehicle transport should utilize the deck.

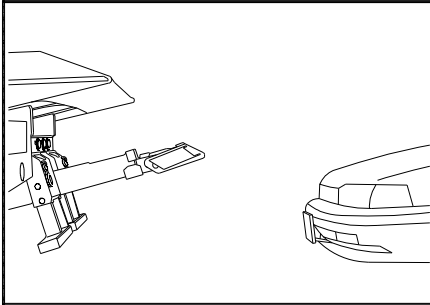

1. Position the truck within three (3) to four (4) feet of the subject vehicle and as close to the direction of the pull as possible.

2a. Set the parking brake.

2b. With the engine running, engage the PTO per instructions in the truck cab or in the PTO Operating Manual.

2c. Set the auxiliary throttle. After operating the unit several times, one will establish a feel for the optimum speed. **DO NOT OVERSPEED.**

Be sure the towed vehicle is not in gear or park. Keep the brake set.

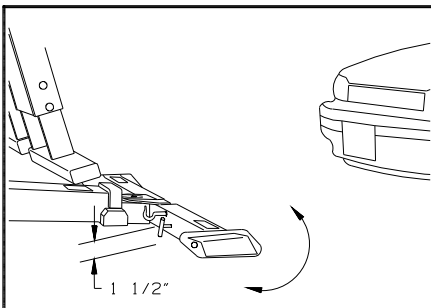

3. Lower the wheel lift arm to about 1-1/2 inches from the ground and swing the cross bar parallel to the tires.

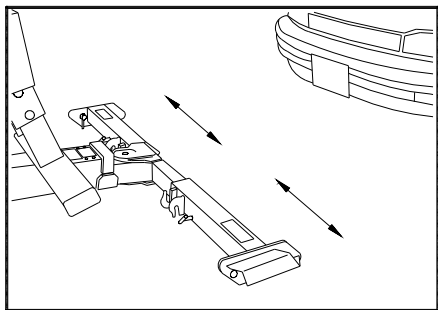

4. Set the grid width as required for the vehicle to be towed. Be sure both grids are as close to the center of the boom as possible.

5. To set the grid width, loosen the "T" handles on the front of the grid arms and pull the grids out. Be sure both grids are as close to the center of the boom as possible, and wide enough to allow the "L" arms to slide into their channels. Tighten the "T" handles to secure the grids.

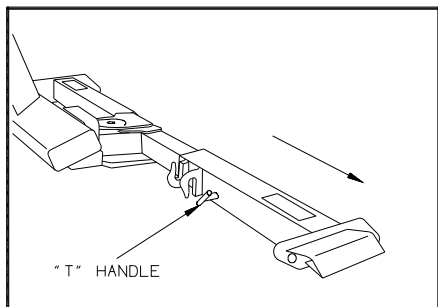

6. Retract the "Cam" handle locking pin on the grid by turning it a half turn. It should remain in the open position.

7. Extend the lift arm under the vehicle being sure that all under carriage parts are cleared and that the front portion of the grid is in contact with both tires. Lower the grid fully to the ground. **There is no reason for the operator to get under the vehicle.**

8. Visually inspect the tire to grid contact before proceeding.

9. Take the "L" arms and slide them into the channels on the side of the grid. Insure that they are resting snugly against the tires, with the "L" arms in close contact with the tires, reset the locking pin by turning the "Cam" handle back to the original position. **Be sure that the pin seats in one of the holes.** The tires are now confined front and back.

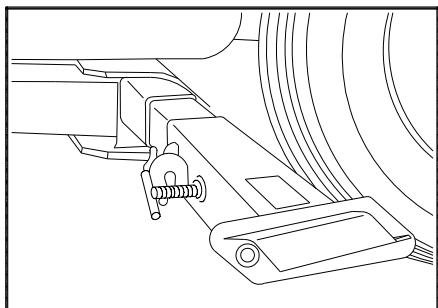
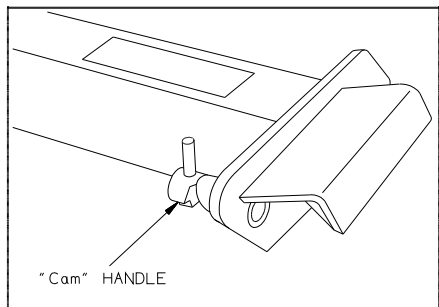

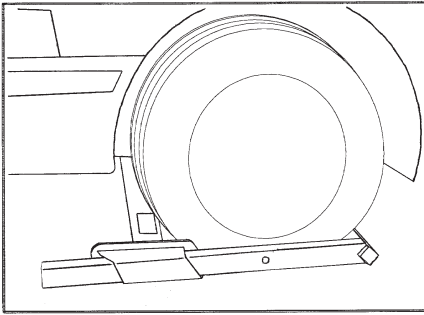

10. After securing the grid arm around the towed vehicle's tires and before making the actual lift, check to be sure the towed vehicle's parking brake is released, the transmission is in neutral, and the wheels are straight.

NOTE: If vehicle to be towed is on a slope, do not release the brake until the tie-down straps are installed. Observe the wheels in the grid for any slippage.

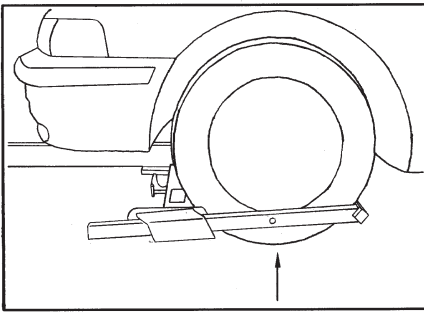

11. It is recommended that the steering wheel of the towed vehicle be secured in the straight position by a steering wheel strap for any tow.

12. Lift the vehicle high enough to allow the tires to clear ground.

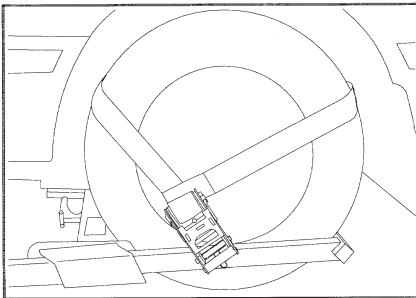

13. Remove the tie-down straps from toolboxes and attach the tie-down straps. (See the following section on the tie-down straps.)

14. With the straps in place, the vehicle in neutral and the parking brake released, you can move the vehicle safely up, down, in or out. All of these movements are hydraulically controlled.

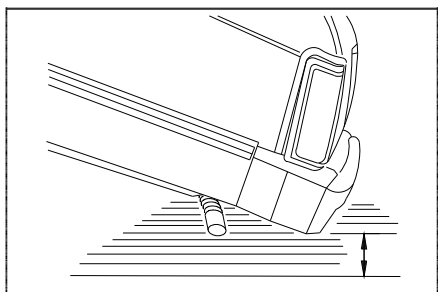

15. Raise the vehicle into the final towing position observing the far end for sufficient ground clearance. It is possible to set the rear of a front lifted vehicle completely onto the ground, causing damage. Take irregular road-surfaces into consideration. Observe the lift function from the side and away from both vehicles if possible. Make sure that there are no under body components of the towed vehicle in contact with the "L" arms or wheel grid device. Readjust if necessary.

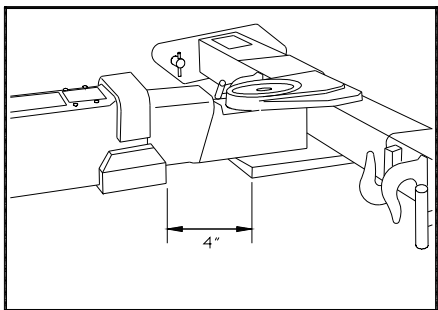

16. Power retract the grid boom until the towed vehicle is about three (3) to four (4) feet from the back of the truck. Leave enough room to maneuver around corners without corner binding or causing contact between the two (2) vehicles. **Be sure that the boom is extended at least 4 inches to insure unobstructed crossbar pivoting.**

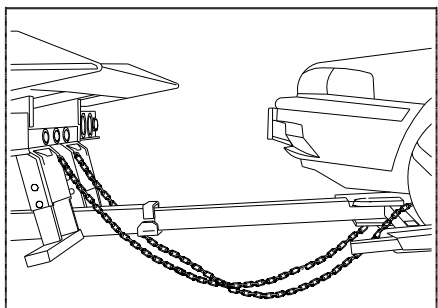



17. Be sure to maintain sufficient clearances with the bottom of the towed vehicle.
18. Attach the safety chains and magnetic towing lights. **SAFETY CHAINS MUST BE CROSSED.**

⚠ CAUTION: Always tow with the tow bar extended so that adequate clearance is maintained between deck and towed vehicle.

⚠ CAUTION: Properly secure the vehicle being towed. Use separate safety chains from towed vehicle to carrier subframe.

 **CAUTION:** After unloading the vehicle being towed, fully retract the wheel lift before tilting or rolling the deck.

 **CAUTION:** When not in use, wheel lift must be in upper position and fully retracted.

 **CAUTION:** The wheel lift option is designed for the transport of an additional vehicle only. Under no circumstances should a vehicle be transported on the wheel lift without a vehicle on the deck as it may cause unsafe steering and braking conditions. Single vehicle transport should utilize the deck.

 **CAUTION:** When not in use, wheel lift “L” arms must be stored in the storage tubes provided on the carrier subframe. “L” arms should never be stored in the wheel grids when not in use.

TIE-DOWN STRAPS

Your carrier is supplied with a set of high strength polyester web tie-down straps. They are to be used to secure wheels of the towed vehicle to the wheel lift grid. **NEVER TOW A VEHICLE WITHOUT THE TIE-DOWN STRAPS INSTALLED.**

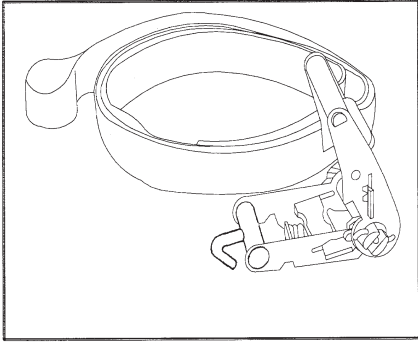

The tie-down strap assembly is comprised of two (2) basic components:

1. The strap
2. The ratchet spool mechanism

The following steps should be followed to properly install the tie-down straps:

USING THE RATCHET SPOOL MECHANISM

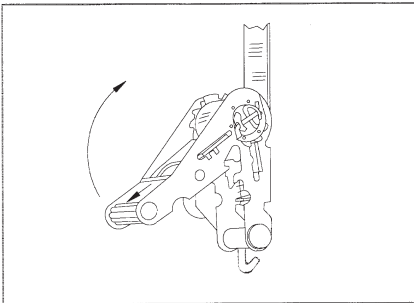

1. First the spool must be set into "free spool". This is done by pulling the lock bar out and swinging the handle upward until it rests in the free spool notch and then simply pulling out the amount of strap required to fit over the tire.

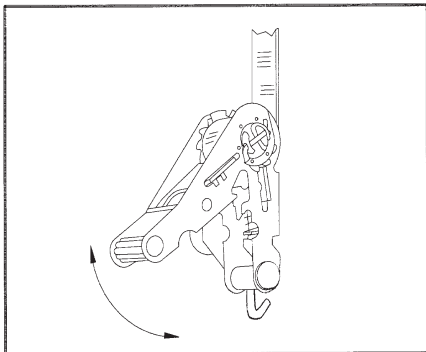

2. Now pull on the lock bar and move it downward until it engages the ratchet teeth on the take up spool. By pushing and pulling the handle up and down, the strap will be wound onto the spool.
3. To release the ratchet, simply pull on the locking bar, disengaging the teeth and raise the handle to the "free spool" position.

INSTALLING THE TIE-DOWN STRAP

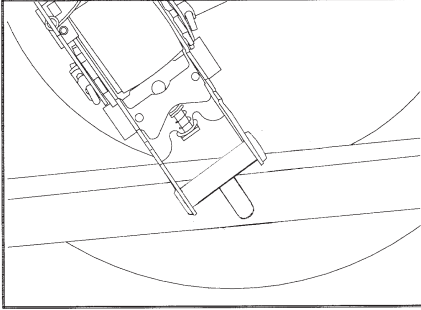

1. With the vehicle lifted just barely off the ground, attach the strap to the wheel grid. Be sure the hook on the ratchet is securely seated in the "L" arm.

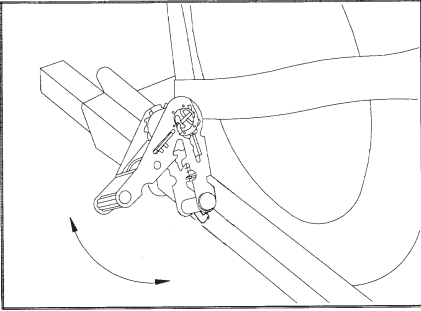

2. Set the ratchet spool in "free spool" position and pull the webbed strap out and form a loop which will wrap around the tire. Be sure the loop is over a minimum of 1/3 of the tire.

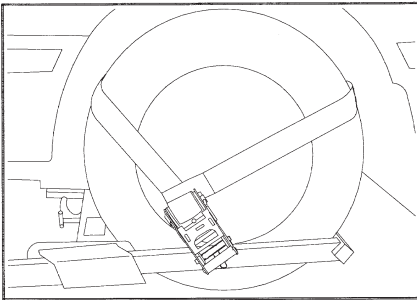

3. Take up the slack in the strap by ratcheting the takeup spool arm. Continue until the tires show some compression.
4. Raise the wheel grid to the towing position. **RE-TIGHTEN THE RATCHET PERIODICALLY AS TIRE SETTLES IN GRID FROM TOWING.**

THIS PAGE INTENTIONALLY LEFT BLANK

MAINTENANCE AND LUBRICATION

Jerr-Dan rollback truck decks are designed for years of service with little maintenance. This small amount of maintenance, however, is very important for durability and for safe operation of the deck.

Maintenance is an owner/user responsibility as neither the manufacturer nor the distributor can normally control this function.

Use only safe practices when maintaining this equipment. Never get under a tilted deck unless it is adequately supported (don't rely on the hydraulic system). Always shut off the engine before reaching into pinch areas as when checking the hydraulic oil level or greasing under the deck. Maintain a clean shop for safety. Clean up spilled oil immediately.

Inspect the vehicle and deck system periodically for damage or evidence of pending failure. Damaged or broken parts should be replaced immediately. Never operate a machine which is known to be defective or operating improperly. The cause of any binding or leakage should be determined immediately and the problem promptly fixed.

Sliding surfaces of deck beams are to be cleaned and coated with engine oil periodically. Cleaning every six (6) months is recommended for normal highway operations, but this frequency will vary appreciably with the type of service. Sliding on dirty wear surfaces will cause rapid wear. Fittings on linkage pivots should be greased every two (2) months, again depending upon usage. See Lube Chart.

Check the hydraulic oil level bimonthly or after any leakage. Use 5W20 Dual Range hydraulic oil. (Automatic transmission fluid may be used in the hydraulic system if necessary.)

The proper oil level is best checked by rolling the deck back enough to gain access to the fill plug (unless the chassis configuration caused the oil tank to be mounted abnormally far to the rear). The oil tank should be about 2/3 full with the deck so positioned (shut off the engine after moving the deck). This will result in a 3/4 full tank with the cylinders fully retracted (deck fully forward). (Proper oil level is achieved when the hydraulic oil is within 1/2 inch of top of sight tube.)

The hydraulic filter located on the return side of the hydraulic tank comes equipped with a restriction indicator gauge. This gauge shows the operator the condition of the filter element. When the needle reaches the red band (25 psi), the filter is starting to bypass and the element needs to be changed. Failure to change the element will result in premature wear and/or failure of any or all of the hydraulic components. **Only check gauge with hydraulic fluid at operating temperatures. Cold oil is more dense and will give a false indicator gauge reading.**

If a cylinder seal leaks, disassemble the cylinder and ascertain the cause of the leak. Small scores caused by chips or contaminated fluid can usually be worked out with fine emory cloth to avoid repetition of the trouble. Whenever any seal replacement is necessary, it is always advisable to replace all seals in that component. These seals are available in kits. Also, thoroughly clean all components before reassembly.

LUBRICATION CHART

JERR-DAN[®]

3-CAR BIC ROLLBACK CARRIERS

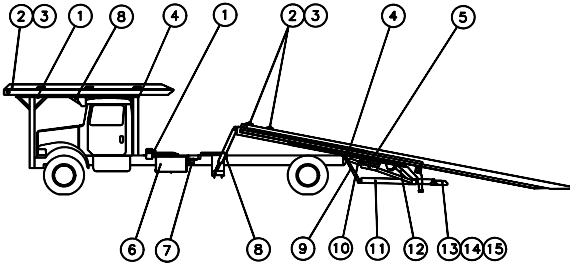

CHART COVERS **JERR-DAN** DECK SYSTEM ONLY

* INDICATES DUAL RANGE HYD. FLUID 5 W 20
 AUTO TRANS FLUID MAY BE SUBSTITUTED IF NECESSARY

DO NOT GREASE SLIDE PADS

382

INTERVAL (HOURS)	REF NO.	IDENTIFICATION	SERVICE	LUBRICANT	NO. OF POINTS
50 OR MONTHLY	2	CABLE	OIL	ENGINE OIL	3
	15	T - HANDLE	OIL	ENGINE OIL	2
100 OR BIMONTHLY	2	WINCH	LUBE	MPG	3
	4	SUBFRAME PIVOT	LUBE	MPG	4
	5	VALVE SPOOLS	CLEAN+OIL	ENGINE OIL	6 - 8
	6	HYD RESERVOIR	CHECK	*	1
	8	TILT CYLINDER	LUBE	MPG	8
	9	CYLINDER/LINK	LUBE	MPG	2
	10	STRUT/STAB ARM	LUBE	MPG	4
	11	BOOM EXT CYL	LUBE	MPG	2
	12	IRL/STAB CYL	LUBE	MPG	4
	13	CAM LOCK	LUBE	MPG	2
14	WL/TB PIVOT	LUBE	MPG	1	
250 OR SEMI- ANNUALLY	1	DECK GUIDES	BRUSH	*	4
	3	WINCH GEAR BOX	CHECK	GL5 #140	3
	7	HYD FILTER	CHANGE	----	1
1000 OPERATING HOURS	3	WINCH GEAR BOX	DRAIN/FILL	GL5 #140	3
	6	HYD RESERVOIR	DRAIN/FILL	*	1

Spool operated hydraulic control valves may build up debris, dirt and/or corrosion under the spring cap. Slower operation of that hydraulic function, even when the control handle is fully actuated, may occur.

It is recommended to annually remove the spring caps on the valve section (usually the opposite side from the spool end clevis) and clean the cap and the items under the cap, to remove any build up.



Apply an approved lubricant to protect those components and reduce the likelihood of further build up. Apply the lubricant generously to spring cap end hardware parts (spring seat, spool end, spring and the inside of the cap itself) to insure complete exposure of all part surfaces to the lubricant. This will ensure optimum operation of your valve sections over the life your equipment.

APPROVED LUBRICANTS:

- Mobiltemp SCH Grease (red)
- Mobilith SCH PM (white)

TROUBLESHOOTING

PROBLEM	CAUSE	SOLUTION
---------	-------	----------

PROBLEMS ENCOUNTERED WHILE UNIT IS IN TRANSIT

Looseness and rattling of deck	a. Loose Hold Down Blocks	a. Shim Hold Down Blocks as required.
--------------------------------	---------------------------	---------------------------------------

WINCH FUNCTIONING IMPROPERLY

Winch screeches during operation	a. Insufficient lubrication	a. Lubricate per lube chart
Winch will not pull load on deck	a. Free spooling device disengaged b. Insufficient Relief Valve pressure c. Sheared keys or broken chain at coupling d. Hydraulic pump worn	a. Engage b. Reset to correct setting using gauge c. Inspect and replace d. Inspect and replace
Cable build-up on one side of spool or other	a. Off centered load	a. Recenter load if possible

VALVE BANK FUNCTIONING IMPROPERLY

Valve bypasses oil or squeals during all operations	a. Insufficient relief valve setting b. Broken relief spring	a. Reset to correct setting using gauge b. Inspect and replace
Valve handles stick, tight or frozen	b. Broken centering spring or clogged with dirt at bottom of spool	b. Inspect, clean or replace
Valve leaks at top or bottom of spools	a. Defective seals	a. Replace

CYLINDERS FUNCTIONING IMPROPERLY

Cylinders leak oil	a. Defective seals or rod	a. Inspect and replace
Erratic operation of cylinders	a. Air in hydraulic system b. Defective pump (Pulsating)	a. Cycle hydraulic system 10-15 times to remove air b. Replace if necessary

HYDRAULIC SYSTEM FUNCTIONING IMPROPERLY

Slow Operation	a. Low engine RPM b. Low oil level c. Blocked, restricted or collapsed hoses d. Dirty hydraulic oil e. Hydraulic pump worn f. Relief valve in valve bank bypassing	a. Speed up engine b. Reservoir should be 3/4 full with cylinders retracted c. Inspect, remove blockage or reposition hoses affected d. Drain, flush and refill with clean oil e. Rebuild or replace f. 1) Reset to correct pressure using gauge 2) Check if relief spring is broken. Replace if necessary
----------------	---	--

TROUBLESHOOTING

PROBLEM

CAUSE

SOLUTION

P.T.O. FUNCTIONING IMPROPERLY

Cable tight or frozen	<ul style="list-style-type: none"> a. Cable kinked or bent b. Cable and P.T.O. connection not adjusted properly c. Mounting bracket nuts are over tightened at P.T.O. knob 	<ul style="list-style-type: none"> a. Straighten or replace b. Inspect and adjust c. Loosen if necessary
Rattling noise in P.T.O.	<ul style="list-style-type: none"> a. P.T.O. backlash too loose 	<ul style="list-style-type: none"> a. Shims must be removed (Consult P.T.O. manual)
Howling noise in P.T.O.	<ul style="list-style-type: none"> a. P.T.O. backlash too tight 	<ul style="list-style-type: none"> a. Shims must be added (Consult P.T.O. manual)
Gear oil leak between P.T.O. and pump	<ul style="list-style-type: none"> a. Defective shaft seal 	<ul style="list-style-type: none"> a. Remove and replace
P.T.O. will not engage or disengage	<ul style="list-style-type: none"> a. Cable and P.T.O. connection not adjusted properly b. Defective shifter cover plate 	<ul style="list-style-type: none"> a. Inspect and adjust b. Inspect and replace

HYDRAULIC PUMP FUNCTIONING IMPROPERLY

Cavitation: pump unusually noisy	<ul style="list-style-type: none"> a. Low oil supply b. Heavy oil c. Dirty oil filter d. Restriction in suction line 	<ul style="list-style-type: none"> a. Fill to proper level b. Fill with proper oil c. Clean or replace d. Remove
Pump takes too long to respond or fails to respond	<ul style="list-style-type: none"> a. Low oil supply b. Insufficient relief valve pressure c. Pump worn or damaged 	<ul style="list-style-type: none"> a. Fill to proper level b. Reset to correct setting using gauge c. Repair or replace
Oil Heating up	<ul style="list-style-type: none"> a. Foreign material lodged in relief valve b. Using too light oil c. Dirty oil d. Oil level too low e. Insufficient relief valve pressure f. Relief valve pressure too high g. Pump worn (slippage) 	<ul style="list-style-type: none"> a. Inspect and remove b. Drain and refill with clean oil c. Drain, flush, and refill with clean oil d. Fill to proper level e. Set to correct setting using gauge f. Same as "e" g. Repair or replace
Oil foaming	<ul style="list-style-type: none"> a. Air leaking into suction line from tank to pump b. Wrong kind of oil c. Oil level too low 	<ul style="list-style-type: none"> a. Tighten all connections b. Drain and refill with non-foaming type hydraulic oil c. Fill to proper level
Hydraulic oil leak between P.T.O. and pump	<ul style="list-style-type: none"> a. Defective shaft seal 	<ul style="list-style-type: none"> a. Replace shaft seal
Pump leaks at front and rear covers	<ul style="list-style-type: none"> a. Defective seals 	<ul style="list-style-type: none"> a. Replace seals

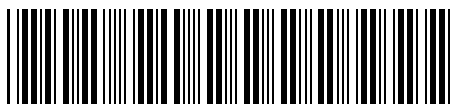

5376000077

JERR-DAN

An Oshkosh Corporation Company

*13224 Fountainhead Plaza
Hagerstown, MD 21742
Phone (717) 597-7111*

TOW 
SUPPORT
by **JERR-DAN**

Phone (800) 926-9666

www.jerr-dan.com